

OWNER'S MANUAL
26" - 5 H.P. RIDING MOWER
MODEL 2650-0200

WARRANTY

ONE YEAR LIMITED WARRANTY

For one (1) year from date of purchase by the first consumer for residential use (thirty (30) days commercial use), Western International Incorporated warrants that it will replace free of charge, including labor, any original part of any Western International Incorporated product found to be defective by any authorized Service Dealer or the factory, except the battery which is warranted for ninety (90) days from date of purchase.

This warranty does not cover engine, transmission, transaxle or differential (these items are covered by their manufacturer's own warranty). This warranty does not cover parts that have failed due to normal wear or parts that have failed subject to misuse or abuse. Transportation of the unit or part to and from an authorized Service Dealer or the factory is the responsibility of the owner.

A step by step explanation as to what procedure should be followed for this Warranty is:

1. If a part becomes defective, contact the store where the unit was purchased for the name and address of the authorized Service Dealer nearest to you.
2. If you cannot locate an authorized Service Dealer, write Service Department of Western International Incorporated for the name and address of the authorized Service Dealer in your area or call the Service Department at 1-800-247-7464 (outside Iowa), 1-515-265-3461 (Iowa).
3. Return the defective product, along with proof of purchase to such authorized Service Dealer for replacement of any defective part where covered by this warranty.

There is no other express warranty. Implied warranties, including those of merchantability and fitness for a particular purpose are limited to one (1) year from date of purchase. Liability for incidental or consequential damages are excluded.

Some states do not allow limitations on how long an implied warranty lasts, so the above limitation may not apply to you. Some states do not allow the exclusion of incidental or consequential damages, so the above exclusion may not apply to you. This warranty gives you specific legal rights, and you may have other rights which vary from state to state.

Western International Incorporated

P.O. Box 377

Des Moines, Iowa 50302

UNIT PARTS AND SERVICE

This manual contains instructions for safety, assembly and maintenance. Read this manual carefully and completely so that you will know proper assembly, use and care of your unit. Also fill in and mail the registration card packed with the unit. For service other than covered in this manual, contact an authorized service dealer. A nationwide parts and service organization has been established to provide locally available parts and service. A list of authorized parts distributors has been included in this manual. When ordering repair parts, always give the following information: 1. The Part Name; 2. The Part Number; 3. The Quantity desired; 4. The Full (eight digit) Model Number of the unit. The model number will be found on a plate attached to the unit.



Look for this symbol.

It means - **ATTENTION! BECOME ALERT! A HAZARD TO OPERATOR, BYSTANDERS, PROPERTY OR EQUIPMENT MAY EXIST.**

WESTERN INTERNATIONAL INCORPORATED

P.O. BOX 377

DES MOINES, IOWA 50302

Part No. 62890

1186



OPERATIONAL PRECAUTIONS



THESE INSTRUCTIONS ARE FOR YOUR PROTECTION. PLEASE READ THEM CAREFULLY.

1. Know the controls and how to stop quickly. **READ THIS OPERATOR'S MANUAL** and instructions furnished with attachments.
2. Wear safety glasses or eye shields when assembling or operating riding mower.
3. Do not allow children to operate the machine. Do not allow adults to operate it without proper instruction.
4. Do not carry passengers. Do not mow when children and others are around. Disengage power to blade(s) or attachment(s) and stop the engine while others are in the vicinity of the mower.
5. Battery fluid (electrolyte) is an **ACID** and is extremely dangerous. Do not smoke while servicing the battery. Do not service battery near an open flame or spark.
6. Handle gasoline with care, it is highly flammable.
 - A. Use approved gasoline container.
 - B. Never remove the fuel cap of, or add gasoline to, a running or hot engine, or an engine that has not been allowed to cool for several minutes after running. Never fill the tank indoors and always clean up spilled gasoline immediately.
 - C. Do not smoke while filling fuel tank.
 - D. Do not run the engine indoors. Open doors if engine must be run in garage. Exhaust fumes contain **CARBON MONOXIDE**, an **ODORLESS** and **DEADLY GAS**.
7. Check fuel supply before each use allowing space for expansion as the heat of the engine and/or sun can cause gasoline to expand.
8. Do not operate mower when barefooted. Always wear substantial footwear, preferably steel-toed shoes. Do not wear loose fitting clothing that could get caught in moving parts.
9. Clear the work area of objects (wire, rocks, etc.) which might be picked up and thrown. Check all controls for proper function.
10. Disengage all attachment clutches, shift to neutral, and set parking brake before attempting to start the engine (motor). When starting engine equipped with a pull starter, stand firm and make sure your feet are well away from the blade(s).
11. Disengage power to blade(s) or other attachment(s) and stop the engine (motor) before leaving the operator's position. Always dismount from left side.
12. Disengage power to blade(s) or other attachment(s) and stop the engine (motor) before making any repairs or adjustments.
13. Disengage power to blade(s) or other attachment(s) when transporting or not in use.
14. Take all possible precautions when leaving the vehicle unattended, such as disengaging power to blade(s) or attachment(s), lower the attachment(s), setting the parking brake, stopping the engine (motor), and removing the key.
15. Do not stop or start suddenly when going uphill or downhill. Mow up and down the face of steep slopes; never across the face.
16. Reduce speed and exercise extreme caution on slopes and in sharp turns to prevent tipping or loss of control. Be especially cautious when changing direction on slopes.
17. Stay alert for holes, rocks, and roots in the terrain and other hidden hazards. Keep away from drop-offs. Never operate your riding mower on wet or slippery grass or at a speed which could cause a skid. Exercise care when mowing around a fixed object to prevent the blade(s) from striking it. Never deliberately run over any foreign object.
18. Always disengage blade control lever before attempting to remove the mower from a hole or other obstruction.
19. Use care when pulling loads or using heavy equipment.
 - A. Use only approved drawbar hitch points.
 - B. Limit loads to those you can safely control.
 - C. Do not turn sharply. Use care when backing.
 - D. Use counterweight(s), wheel weights or tire chains when suggested in attachment(s) instructions.
20. Watch for traffic when crossing or near roadways.
21. When using attachment(s), never direct discharge of material toward bystanders nor allow anyone near the vehicle while in operation.
22. Keep the vehicle and attachments in good operating condition, and keep safety devices in place and in working condition.
23. Keep all nuts, bolts, and screws tight to be sure the equipment is in safe working condition.
24. Never store the equipment with gasoline in the tank inside a building where fumes may reach an open flame or spark. Allow the engine to cool before storing in any enclosure.
25. To reduce fire hazard, keep the engine free of grass, leaves, or excessive grease.
26. The vehicle and attachments should be stopped and inspected for damage after striking a foreign object, and the damage should be repaired before restarting and operating the equipment.
27. Do not change the engine governor settings or overspeed engine.
28. When using the vehicle with mower, proceed as follows:
 - A. Mow only in daylight or in good artificial light.
 - B. Never make a cutting height adjustment while the engine (motor) is running if the operator must dismount to do so.
 - C. Shut the engine (motor) off when removing the grass catcher or unclogging chute.
 - D. Check the blade mounting bolts for proper tightness at frequent intervals.
29. Under normal usage, the grass catcher bag material is subject to deterioration and wear. Check bag frequently for deterioration and wear and replace worn bags. Check that replacement bags comply with the original manufacturer's recommendations or specifications.
30. Disengage power to mower before backing up. Do not mow in reverse unless absolutely necessary and then only after careful observation of the entire area behind the mower.

OWNER'S INFORMATION

Record the following information about your unit so that you will be able to provide it in case of loss or theft.

MODEL NUMBER 2650-0200

PURCHASE DATE ____ / ____ / ____ CODE NO. _____ SERIAL NO. _____

DEALER'S NAME AND ADDRESS _____

CITY _____ STATE _____ TELEPHONE _____

WARNING

This riding mower is equipped with an internal combustion engine and should not be used on or near any unimproved forest-covered, brush-covered, grass-covered land unless the engine's exhaust system is equipped with a spark arrester meeting applicable local or state laws (if any). If a spark arrester is used, it should be maintained in effective working order by the operator. See your authorized Engine Service Dealer for proper spark arrester muffler for the engine on your riding mower.

TOOLS REQUIRED FOR ASSEMBLY

- 1 - 7/16 inch Wrench (or adjustable wrench)
- 1 - 1/2 inch Wrench (or adjustable wrench)
- 2 - 9/16 inch Wrenches (or adjustable wrenches)
- 1 - Hammer (plastic or rawhide preferred)

⚠ DANGER ⚠

This riding mower can be dangerous if carelessly used.

Read Operator's Manual thoroughly before operating riding mower.

Always wear safety glasses or eye shields while assembling or operating riding mower.

DO NOT carry passengers at any time.

Keep hands, feet, hair and loose clothing away from discharge area, underside of mower deck or any moving parts while engine is running.

DO NOT allow children or young teenagers to operate or be near riding mower while it is operating.

CONTENTS OF SHIPPING CARTON

- 1 - 26 inch Riding Mower
- 1 - Engine Manual
- 1 - Owner's Manual
- 1 - Steering Wheel
- 1 - Steering Shaft
- 1 - Decorative Tube (steering shaft cover)
- 1 - Chute Deflector
- 1 - Seat
- 1 - Bag of Assembly Parts Containing:
 - 1 - 1/4 x 2 1/4 inch Roll Pin
 - 1 - 3/16 x 1 1/4 inch Roll Pin
 - 4 - 1/4 x 1/2 inch Hex Head Screws
 - 4 - 1/4 inch Locknuts
 - 4 - 5/16 x 1/2 inch Hex Head Screws
 - 4 - 5/16 inch Split Lockwashers
 - 1 - 3/8 x 3 1/2 inch Eye Bolt
 - 2 - 3/8 inch Hex Nuts

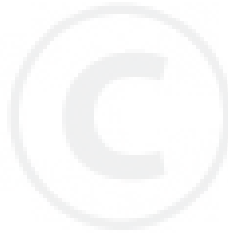

ASSEMBLY

Your riding mower is right side or left side as you face forward while seated in operators seat.

STEERING ASSEMBLY

1. Position front wheels straight forward.
2. Slide steering shaft into steering post and align cross hole in shaft with hole in post. Using a hammer, drive a 3/16 x 1 1/4 inch roll pin through hole (see figure 1).
3. Slide decorative tube over steering shaft and over raised area on console. Tap decorative tube with hammer until it is completely seated onto console.
4. Align cross hole in steering wheel with cross hole in steering shaft and drive a 1/4 x 2 1/4 inch roll pin through hole (figure 1).

Figure 1

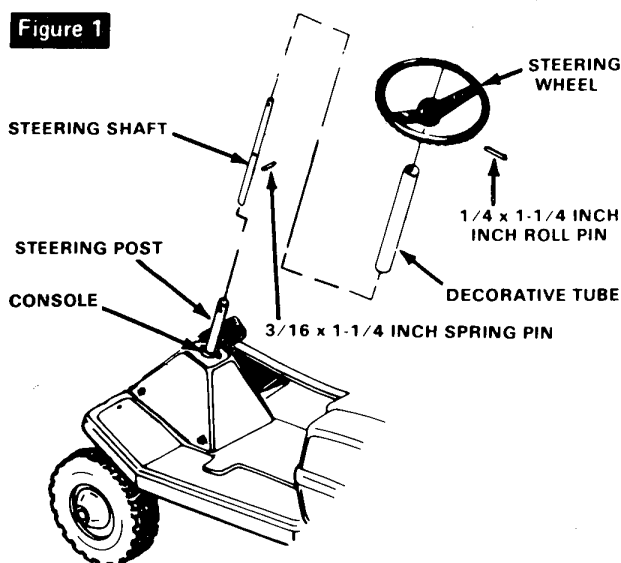

SEAT ASSEMBLY

Install seat using four 5/16 x 1/2 inch screws and 5/16 inch split lockwashers (see figure 2).

Figure 2

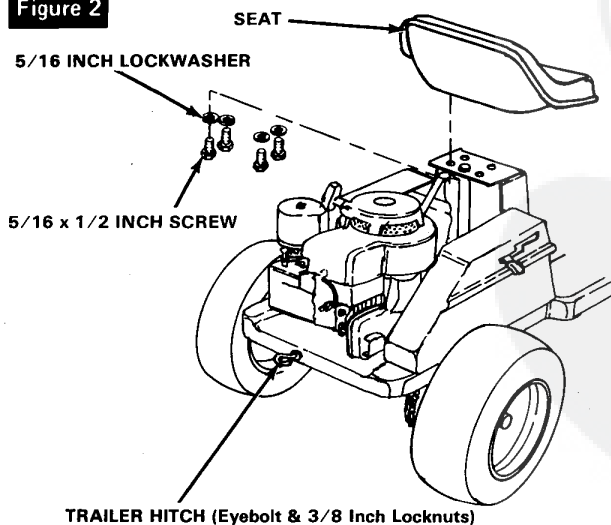

TRAILER HITCH INSTALLATION

The trailer hitch consists of a long eyebolt and two 3/8 inch locknuts. Place one locknut on eyebolt and thread it approximately halfway onto threaded portion of bolt. Insert threaded end of bolt through hole in main frame rear (figure 2) and fasten using other locknut. Hitch can be adjusted either direction by loosening outer locknut and then tightening inner nut or vice versa.

CHUTE DEFLECTOR ASSEMBLY

Install chute deflector (figure 3) over mower deck opening. Secure to deck with four 1/4 x 1/2 inch screws and 1/4 inch locknuts.

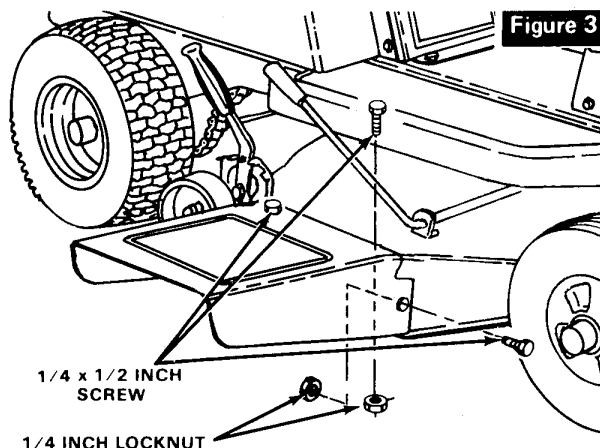

TO SERVICE ENGINE

1. Place mower so engine is in a level position.
2. Fill engine crankcase with oil. See **Engine Operation and Maintenance Manual** for proper procedure.
3. Reinstall oil fill cap and tighten securely.
4. Check to make sure that spark plug is tightened securely into engine and spark plug wire is attached to plug.
5. Fill gas tank with clean, fresh lead-free gasoline with a minimum rating of 77 octane. Low lead or regular grade leaded gasolines are acceptable. **DO NOT mix oil with gasoline.** Be certain container is clean and free from rust or other foreign particles. Never use gasoline that may be stale from long periods of storage in the container.

⚠ DANGER ⚠

Never fill the gas tank while the engine is running or is hot. Immediately wipe off any spilled gasoline before attempting to start engine.

TO SERVICE RIDER

1. Check rear tire pressure. Correct tire pressure (12 to 15 pounds) should be printed on sidewalls of tires. Be sure that tires are inflated equally on both sides.
2. Check all screws and nuts to be sure none are loose.
3. Return to **Step 11** of paragraph **To Activate Battery** and complete battery installation.

OPERATION

The operation of this riding mower can result in objects being thrown into the eyes, which can result in severe eye damage. Always wear safety glasses or eye shields while operating a riding mower. We recommend standard safety glasses or Wide Vision Safety Mask for over spectacles.

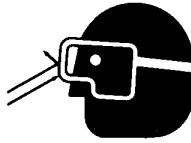

Get to know your riding mower and its controls. Be sure you (or any other operator) have read and understood the **Operational Precautions** listed on page 2 of this manual.

Your new mower will give years of service if cared for properly. Never run into trees, curbs, etc. Service regularly and store in a dry area. Operate your mower at slow speeds until you become familiar with the machine. Avoid sharp turns at high speed and uphill or downhill turns. Operate mower carefully. Be especially cautious on hills. When riding down inclines, keep shift control in low speed with brake-clutch pedal out. This allows the engine to control the speed. Use brake for fast stops on hill.

KEEP MOWER CLEAN. Grass clippings may pack under the mower chassis due to the internal moisture content of the grass. This accumulation of cut grass should be removed after each mowing. Disconnect spark plug wire, remove ignition key and scrape accumulation off with a putty knife or similar tool. Cleaning of under side is easier if mower deck is removed. See **Mower Deck Removal** paragraph in **Adjustment** section of this manual. Remove dirt and debris from engine area with a brush or cloth.

⚠ DANGER ⚠

DO NOT operate this mower without the chute deflector in place. A riding mower can be dangerous to operate if misused. On slopes, be very cautious and avoid sharp turns to prevent tipping or loss of control. NEVER carry passengers.

CONTROLS

Figure 4 shows all operating controls. The controls and their functions are as follows:

- **Throttle Control Lever** - Regulates engine speed and is used to choke engine.
- **Ignition Switch** - Used to start and stop engine. Turn key to START position to allow engine to be started. Turn key to OFF position to stop engine. Remove key to lock ignition.
- **Brake-Clutch Pedal** - This is a dual purpose control. Press pedal halfway down to disengage clutch. It is used for changing speed range or direction of travel (forward or reverse). Release pedal to engage clutch. With pedal completely depressed, brake is applied.
- **Parking Brake Lever** - Used to lock brake-clutch pedal in brake applied position. **NOTE:** Check gear shift position and know operating intentions before releasing brake.
 1. Depress brake-clutch pedal fully, engaging brake.
 2. Push parking brake lever forward and engage notch on lower end of lever against slot in main frame.
 3. To release parking brake, apply pressure to pedal and spring will release parking brake lever.
- **Shift Control Lever** - Used to select ground speed ranges as well as direction of travel (forward-neutral-reverse). Raise lever and push forward to shift into forward speed ranges. Push lever down and back for reverse. Forward speed ranges are labeled 1-2-3.

First range is slowest forward speed (used for extremely heavy mowing).

Second range will be best mowing speed.

Third range will be used for light mowing and non-mowing transportation of mower.

⚠ CAUTION ⚠

Come to full stop before changing gears.

- **Mower Clutch Lever** - Used to connect or disconnect the power to the blade at any time while power to the drive wheels is still maintained and controllable. With mower clutch lever moved all the way to DISENGAGE (rearward) position, blade should stop in a short period of time. Use DISENGAGE position when using as a tractor for yard jobs such as pulling a sweeper.

1. Move lever slowly (Never "snap" the lever) toward front of mower to engage power to blade. It is important to engage mower clutch lever while engine is running at full speed. This prevents excessive strain to the belt.

2. Move lever toward rear of mower to disengage power to blade and to apply blade brake.

Mower clutch lever must always be in full DISENGAGE position to start engine. Never place lever in ENGAGE position until engine is warmed up and operator is on seat, ready to start mowing. Always return lever to DISENGAGE before shifting to reverse and before dismounting from riding mower.

⚠ DANGER ⚠

Blades will not stop immediately. Keep hands and feet from under mower and away from the discharge chute.

- **Cutting Height Adjustment Lever** - Used to change height of cut. The front notch on quadrant is lowest cutting height and rear notch is highest cutting height.

1. Grasp lever (figure 4) with right hand and push outward to disengage lever from notch on quadrant.
2. Move lever to desired cutting height (toward rear of mower for high cut and forward for low cut).
3. After positioning lever at desired height of cut, be sure lever engages notch on quadrant completely.

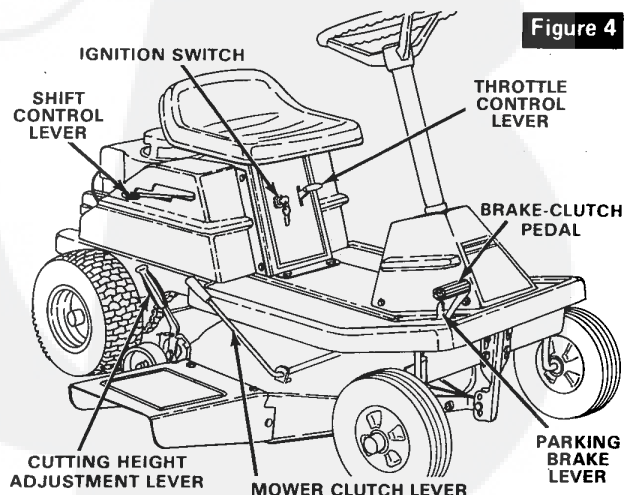

Figure 4

TO START ENGINE (Check oil level)

IMPORTANT: Your mower has two lockout switches connecting the control module on engine to the brake-clutch mechanism and the mower clutch lever. When starting the engine, the brake-clutch pedal must be fully depressed and mower clutch lever must be in full DISENGAGE position to engage the lockout switches. The engine will not start unless these conditions are met. **NOTE:** The engine is supplied with **NO OIL**. Be sure that oil has been added. To start engine, proceed as follows.

1. Check to make sure fuel tank contains clean, fresh gasoline, and engine crankcase is full of oil.
2. Depress brake-clutch pedal all the way down and set parking brake. Place shift lever in NEUTRAL position.
3. Place mower clutch lever to DISENGAGE position.
4. Place throttle control lever to START position.
5. Turn ignition key to START position.
6. Pull starter handle with a fast, steady pull. Do not allow handle to snap back, rewind slowly.
7. After engine starts, move throttle control lever to desired engine speed.

If engine fails to start, proceed as follows:

1. Be sure brake-clutch pedal is fully depressed, parking brake is set and mower clutch lever is in DISENGAGE position.
2. Be sure deck safety wire is connected to wire harness.
3. Check to make sure fuel tank contains clean, fresh gasoline.
4. Check to make sure spark plug is tightened securely into engine and spark plug wire is attached to spark plug.
5. Carburetor adjustment may be necessary (see **Engine Operation and Maintenance Manual** for proper procedure).

DANGER

Never run engine indoors or in enclosed, poorly ventilated areas. Engine exhaust contains CARBON MONOXIDE, an ODORLESS and DEADLY GAS.

Keep hands, feet, hair and loose clothing away from any moving parts on engine or riding mower.

WARNING - Temperature of muffler and nearby areas may exceed 150° F. Avoid these areas.

RIDING MOWER OPERATION

Start engine as outlined and take a comfortable position on seat of riding mower. After engine warmup, depress brake-clutch pedal halfway and move shift control lever to desired gear. **Slowly** release brake-clutch pedal to start riding mower in motion. Until you get the feel of the riding mower, stay near the slow throttle position. To change gear range, depress brake-clutch pedal fully, come to a complete stop, and move shift lever to desired position. With mower blade stopped, make your first run in a large, open, level area. Learn to start, stop, and change direction in this area.

Once you learn to maneuver your riding mower, increase throttle speed to fast. **Slowly** move mower clutch lever to ENGAGE position and start mowing. To stop blade, move lever to DISENGAGE position.

To stop engine, turn ignition key to OFF position. **CAUTION: Disengage mower clutch lever, set parking brake, stop engine, and remove key before leaving operators position. Always dismount from left side.**



CAUTION

TO AVOID INJURY

- Read Operator's Manual(s).
- Know location & function of all controls.
- Keep safety devices (guards, shields, and switches in place and working.
- Remove objects that could be thrown by blade.
- Do not mow when children & others are around.
- Never carry children.
- Always look behind machine before backing.
- Do not mow where machine could tip or slip.
- If machine stops going uphill, stop blade and back slowly down.
- Be sure blade & engine are stopped before placing hands or feet near blade.
- Remove key when leaving machine.

MOWING HINTS

The engine should be run at full throttle and ground speed controlled by shift lever position. Forward speed of the riding mower must be controlled in accordance with the type and quantity of grass being mowed. The more grass that must be cut, the slower the speed forward should be. When cutting light grass, the forward speed can be increased. By observing the cutting action of your mower, you can determine how fast you can travel.

Long and tender grass has a high internal moisture content and is easily depressed by the riding mower wheels, and may not always spring back in time to be cut. To overcome this condition, we advise mowing the lawn in a counterclockwise direction, overlapping previous cut, which allows the lifting action of the rotating blade to lift the grass into the cutting path.

The rear wheels are driven by a differential, similar to an automobile differential. This makes short turns possible and prevents marring of the lawn. It is possible to spin the drive wheels of the riding mower under adverse conditions. When one wheel slips, shift your weight over this wheel to obtain more pulling power. Your riding mower is very maneuverable and can be reversed to back out of dead ends. **CAUTION: Disengage mower blades before backing up. Carefully check area behind mower for children or pets.**

ADJUSTMENTS

⚠ DANGER ⚠

Keep hands, feet, hair and loose clothing away from any moving parts on engine or riding mower when making any adjustments that requires engine to be running.

Always stop the engine, remove ignition key and disconnect spark plug wire before making any adjustments or repairs to the riding mower.

INTRODUCTION TO MECHANISM ADJUSTMENTS

Located beneath the main frame is a v-belt that transmits power to the transmission which, in turn, transmits power (with a drive chain) to the rear wheels; a v-belt that transmits power to the mower blade; linkage that connects the brake-clutch pedal to the brake on the differential; and linkage that connects the brake-clutch pedal to the clutching idler pulley.

The clutch that disengages power to the blade and a deck assembly leveling adjustment are located on the mower deck.

It is necessary to remove mower deck to replace the transmission drive belt. Although it is not necessary to remove the mower deck to make the other adjustments, it is more convenient if several, or all, adjustments are to be made.

⚠ CAUTION ⚠

At no time during maintenance or adjustments can the riding mower be lifted more than 20 inches from level position without taking the following precautions:

1. Remove gasoline from tank and run engine until carburetor is dry.
2. Remove oil from crankcase.

MOWER DECK REMOVAL

1. Disconnect spark plug wire.
2. Set mower clutch lever to the disengaged position to relieve tension on the mower blade drive belt.
3. Disconnect the deck safety wire from wire harness (figure 5) under the main frame. **NOTE:** the by-pass wire (figure 5) must be connected to the wire harness on the main frame in order to start the engine while deck is removed.
4. Remove hairpin cotter from pull pin (figure 6) on the front of the mower deck and remove pull pin.

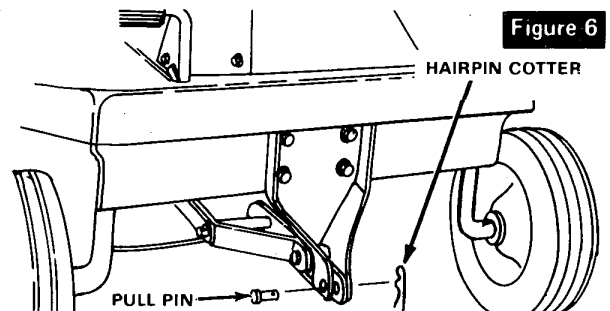

Figure 6

5. Spring lower engine pulley belt guide away from belt enough to allow deck belt to be removed from engine pulley.
6. Move deck forward to disengage the rear deck guide (figure 7) from the guide bar (figure 5) which is attached to the underside of the mower main frame.
7. The deck is now completely free of the mower and can be removed by lifting front of mower and setting rider to the side away from mower deck controls.
8. Installation of mower deck is reverse of removal.
9. Reconnect deck safety wire to wire harness and reconnect spark plug wire.

Figure 5

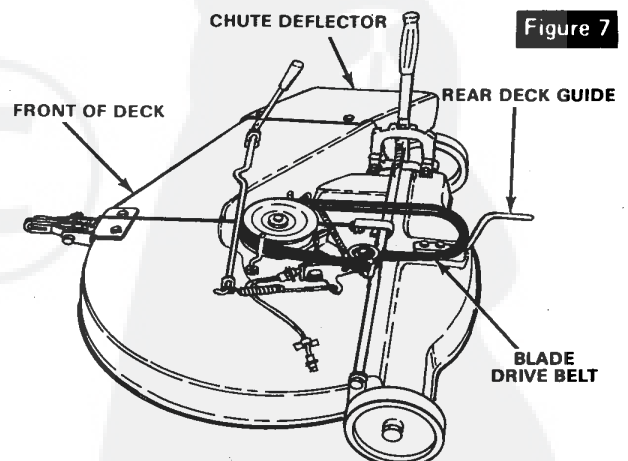
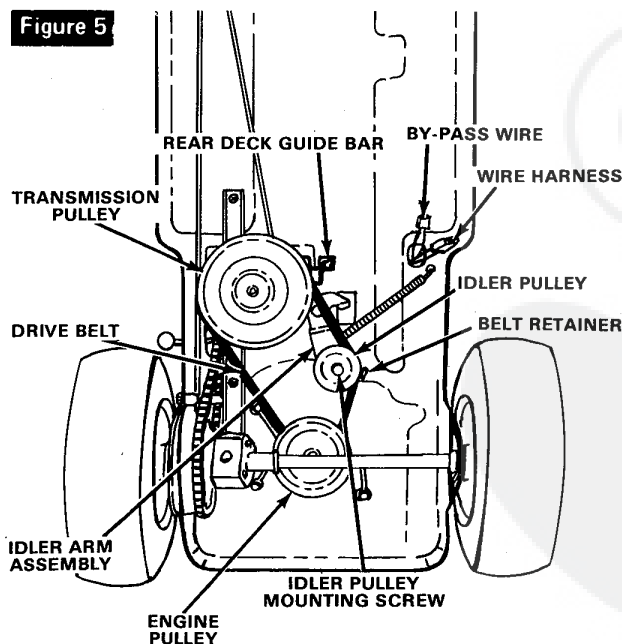

Figure 7

RIDING MOWER DRIVE BELT ADJUSTMENT

The drive belt is kept tight by a spring attached to the idler arm assembly. When drive belt is properly adjusted, with brake clutch pedal fully released (pedal should be slightly loose with no tension) and transmission in neutral position, you should not be able to turn transmission pulley by hand. If you can turn transmission pulley, drive belt adjustment is too loose and you need to tighten drive belt.

With parking brake lever set in first notch you should be able to turn transmission pulley freely. To adjust riding mower drive belt proceed as follows:

1. Disconnect spark plug wire and remove mower deck (see **Mower Deck Removal** paragraph).
2. Set parking brake lever in third notch.
3. Note position of belt retainer on idler pulley (figure 5) so that it can be repositioned properly after drive belt adjustment. Loosen idler pulley mounting screw.
4. Slide idler pulley slightly outward (in slotted idler arm assembly) to tighten belt. Slide idler pulley slightly inward to loosen belt.
5. Relocate idler pulley belt retainer and tighten idler pulley mounting screw.
6. Release parking brake and check drive belt adjustment as described above. Readjust if necessary.
7. Check riding mower brake adjustment as outlined in paragraph **Riding Mower Brake Adjustment**.
8. Reinstall mower deck and reconnect spark plug wire.

RIDING MOWER BRAKE ADJUSTMENT

This riding mower is equipped with a band brake mounted on the differential. Place shift control lever to neutral position and depress brake-clutch pedal enough to latch parking brake lever in third notch. Brake should be disengaged and you should be able to push riding mower. If you are unable to push riding mower, brake is too tight and you need to loosen brake. With shift control lever in neutral position and parking brake lever in sixth notch, brake should be applied. If you are able to push riding mower, brake is too loose and you need to tighten brake. Brake must be set when parking brake lever is in the sixth and seventh position. To adjust brake, proceed as follows:

1. Disconnect spark plug wire.
2. To tighten riding mower brake, loosen rear jam nut (figure 8) on brake rod a turn or two.
3. Tighten front locknut.
4. Check mower brake adjustment as described above.
5. To loosen riding mower brake, loosen front locknut (figure 8) on brake rod a turn or two.
6. Tighten rear jam nut.
7. Check mower brake adjustment as described above.
8. Reconnect spark plug wire.

Figure 8

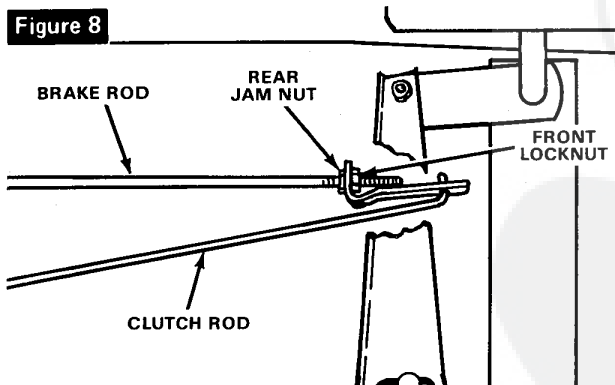

BLADE DRIVE BELT ADJUSTMENT

When mower blade will not run to full speed or belt slips while mowing, the blade drive belt should be tightened. To adjust:

1. Disconnect spark plug wire and place mower clutch lever in disengage position.

2. Loosen locknut on screw securing bar hitch to pivot bracket (figure 9).

3. Slide mower deck forward to tighten belt. **NOTE:** Only a small amount of movement should be required.

4. Retighten locknut on bar hitch screw.

5. To check adjustment, reconnect spark plug wire, start and run engine at FAST throttle setting. Engage mower clutch lever and allow sufficient time for blade to run to full speed, then disengage mower clutch lever. Blade should stop within a few seconds and remain stopped. If blade does not stop or tends to creep, adjustment is too tight.

DANGER

Keep hands, feet, hair and loose clothing away from any moving parts on engine or riding mower when making any adjustments that require engine to be running. **DO NOT** carry passengers.

6. To loosen blade drive belt, reverse step 3 above.

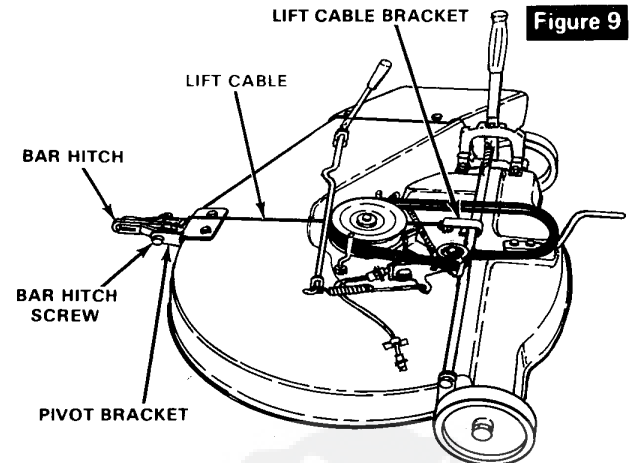

Figure 9

MOWER DECK LEVELING ADJUSTMENT

The cutting height (from blade tip to ground) should be from 0 inch to 1/8 inch less at front of deck than at rear of deck. To adjust:

1. Disconnect spark plug wire.
2. Measure height of blade from level floor at front and rear deck (make sure tires are properly inflated). If distances are equal or not more than 1/8 inch less in the front, no adjustment is necessary.
3. If adjustment is necessary, place cutting height adjustment lever in extreme low cut position (full forward).
4. Place a block under front of mower deck (figure 9) to remove weight from the hitch. Lift cable will be slack.
5. Loosen nut on cable in front of cable bracket.
6. Tighten rear nut on cable to raise front of deck. Each 1 1/2 complete turns of nut represents approximately 1/8 inch change in the front of mower deck.
7. Loosen rear nut and tighten front nut to lower front of deck. Tighten both nuts securely.
8. Remove block. Check front and rear measurements. Repeat above instructions if measurement is still incorrect.

DRIVE CHAIN ADJUSTMENT

The drive chain that transmits power from the transmission to the rear wheels will wear. The excess slack that develops will have to be removed. **To adjust:**

1. Disconnect spark plug wire.
2. Set rear of mower up on blocks and remove rear wheels by removing hub caps and E-Rings.
3. Loosen the two bolts in top of each rear axle mounting bracket bearing assembly (see figure 10).

Figure 10

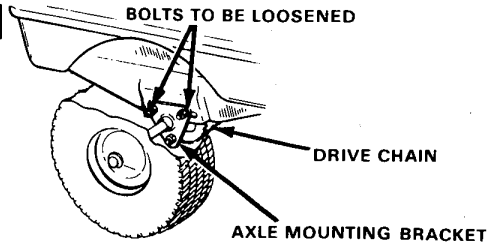

4. Slide right side axle toward rear of mower to remove excess slack in chain.
5. Slide left side axle back an equal amount and compare slot openings on both sides to be sure both axles were moved an equal amount.
6. Retighten axle bracket bolts.
7. Proper tension will permit chain to be depressed approximately $\frac{1}{8}$ to $\frac{1}{4}$ inch with light finger pressure on the chain.
8. Adjust brake rod if necessary as instructed in **Riding Mower Brake Adjustment** paragraph.
9. Reconnect spark plug wire.

CARBURETOR ADJUSTMENT

Never make unnecessary adjustments. The factory settings are correct for most applications. If necessary, however, refer to **Engine Operation and Maintenance Manual**.

MAINTENANCE

Your mower uses two v-belts made of special compounds. If either belt becomes worn or breaks, replace with **original equipment belts** (see **Repair Parts** section if this manual). **NEVER USE A SUBSTITUTE.**

Figure 11

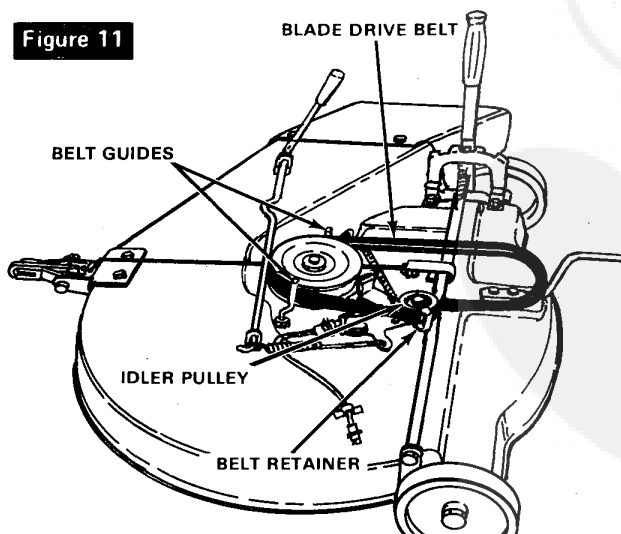

TO REPLACE BLADE DRIVE BELT

1. Disconnect spark plug wire and remove mower deck (see **Mower Deck Removal** paragraph in **ADJUSTMENT** section of this manual).
2. Note position of belt retainer on idler pulley (figure 11) so that retainer can be reinstalled to proper position. Loosen idler pulley mounting screw enough to allow belt to be removed between pulley and retainer.
3. Loosen both mower deck belt guides (figure 11) enough to allow belt to be removed from pulley.
4. Remove old belt.
5. Replace belt, retighten belt guides and idler pulley and adjust belt retainer on idler pulley (see step 2 above).
6. Adjust belt as described in **Blade Drive Belt Adjustment** paragraph in **Adjustment** section of this manual.
7. Reconnect spark plug wire.

TO REPLACE TRANSMISSION AND ENGINE DRIVE BELT

1. Disconnect spark plug wire and remove mower deck (see **Mower Deck Removal** paragraph in **Adjustment** section of this manual).

2. Place shift lever in NEUTRAL position.
3. Depress brake-clutch pedal and set parking brake.
4. Loosen screws holding deck guide bar (figure 12) enough to allow belt to pass between guide bar and transmission pulley.
5. Note position of belt retainer on idler pulley (figure 12) so it can be repositioned properly after belt installation. Loosen nut that holds belt retainer to idler pulley and remove belt from pulley.
6. Roll belt off transmission pulley.
7. Spring engine pulley belt guides away from pulley enough to allow belt to be removed from pulley.
8. Replace belt with **genuine replacement part** and reassemble in reverse order of removal. Position idler pulley belt retainer at same angle as it was before loosening.
9. Reposition deck guide bar $\frac{1}{8}$ inch from transmission pulley and tighten screws securely.
10. Check belt tension and adjust if necessary as instructed in **Riding Mower Drive Belt Adjustment** paragraph in **Adjustment** section of this manual.
11. If blade drive belt needs replacement, do so before reinstalling mower deck assembly.
12. Reinstall mower deck and reconnect spark plug wire.

Figure 12

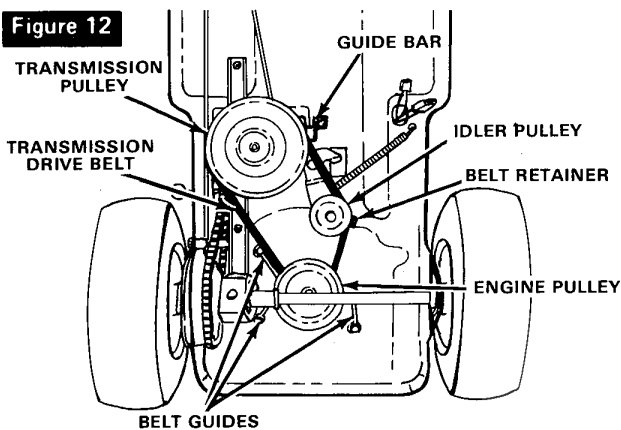

DRIVE CHAIN REPLACEMENT

If drive chain ever needs replacement, replace with an **original equipment chain** as listed in **Repair Parts** section of this manual.

2. Loosen chain by sliding rear axle forward (see **Drive Chain Adjustment** paragraph in **Adjustment** section of this manual).
3. Locate connector link in chain.
4. Remove keeper link from connector link and remove chain. **NOTE:** Be sure to notice direction of open end of keeper on link so new link can be installed in same manner.
5. Install new chain and secure with connector link (open end of link keeper (figure 13) must trail when chain is moved in direction of forward drive).
6. Adjust chain as instructed in **Drive Chain Adjustment** paragraph in **Adjustment** section of this manual.

Figure 13

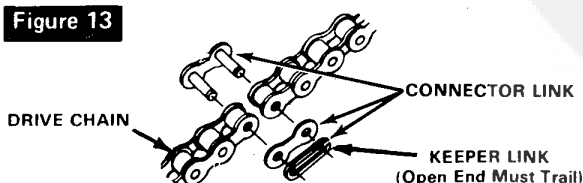

7. Check brake adjustment see **Riding Mower Brake Adjustment** paragraph in **Adjustment** section of this manual.

8. Reconnect spark plug wire.

BLADE REPLACEMENT

The cutting blade should be sharp and well-balanced to run smoothly. Blade should have correct amount of "lift" for proper cutting and discharge of clippings. Lift is created by upturned bent tip edges (figure 14) of blade ends. As cutting edges of blade wear, the bent tip edges also wear, decreasing blade lift, resulting in decreased cutting ability. Because of this, resharpening of blade will not help much. It is recommended that blade be replaced.

IMPORTANT: Stop engine, disconnect spark plug wire and inspect blade at once if you strike any solid unyielding object. Check to make sure blade mounting screw is tight. To remove blade:

1. Disconnect spark plug wire and remove mower deck. See **Mower Deck Removal** paragraph.
2. With a 9/16 inch wrench, remove blade mounting screw (figure 15) by turning screw counter-clockwise.

⚠ DANGER ⚠

DO NOT handle blade with bare hands. Wear gloves or wrap blade with newspaper or other material while removing or reinstalling blade.

When replacing blade, be sure all parts are reassembled in proper order (see **Repair Parts Manual** for proper order) or severe vibration will occur. Bent tip edges of blade must be up toward top of mower deck or blade will not cut. **NOTE: Make sure blade mounting screw is tightened securely.** We recommend a 10 inch wrench or a torque wrench. If torque wrench is used, torque blade mounting screw to between 30 and 35 foot pounds.

3. Reinstall mower deck, reconnect deck wire to unit wire harness and reconnect spark plug wire.

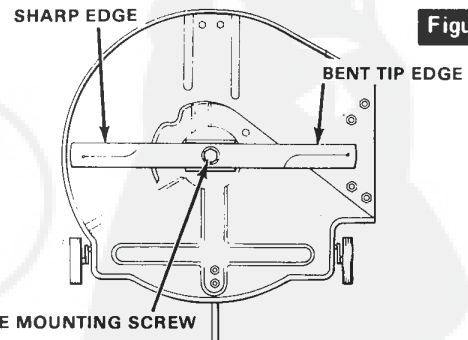

Figure 14

TO CHANGE CRANKCASE OIL

1. Disconnect spark plug wire and remove mower deck. See **Mower Deck Removal** paragraph in **Adjustment** section of this manual.
2. Place a flat pan under rear of mower to catch oil.
3. Remove oil drain plug at bottom of oil fill tube (located under main frame on left side of engine) and drain oil into pan. **NOTE:** Oil fill cap should be loosened to serve as an air vent.
4. After oil has drained, reinstall oil drain plug and wipe off any spilled oil.
5. Refill with oil (see **Engine Operation and Maintenance Manual** for proper procedure).
6. Reinstall mower deck and reconnect spark plug wire.

AIR FILTER MAINTENANCE

The air filter should be cleaned and re-oiled after every 25 hours of operation under normal operating conditions; more often under dusty conditions. To clean air filter, proceed as instructed in **Engine Operation and Maintenance Manual**.

⚠ CAUTION ⚠

Never run the engine without the air cleaner element installed. A defective air cleaner can result in loss of engine power and can cause excessive wear or damage to engine components if dirt or dust is permitted to enter engine through the carburetor. A damaged air cleaner, or one that is clogged with dust or dirt should be replaced immediately.

SPARK PLUG MAINTENANCE

Spark plug should be checked periodically for excessive carbon and gap. The spark plug gap should be checked with a wire feeler gauge and set at .030 inch.

ENGINE CARE

See **Engine Operation and Maintenance Manual** for engine, carburetor and spark plug information.

LUBRICATION

Lubricate as instructed in **Lubrication Chart** and **Preventive Maintenance Chart**.

The transmission and differential have been lubricated for lift at the factory.

WIRING DIAGRAM

The parts diagram on page 22 of this manual is designed to be used as a wiring diagram.

We recommend that unless you are fully qualified to make repairs on the electrical system on this mower, you take it to a competent repairman for such work or adjustments.

LUBRICATION CHART

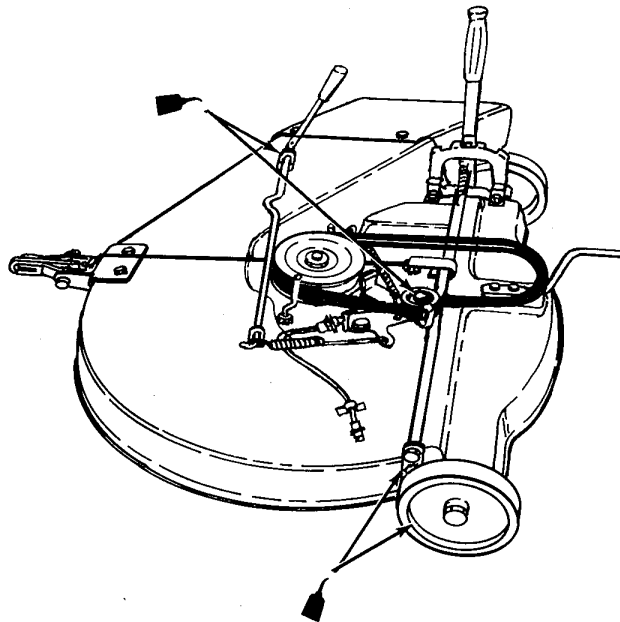
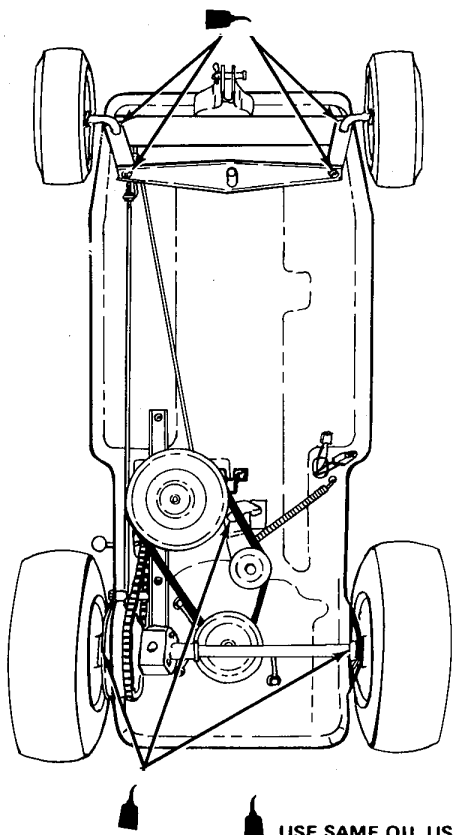

USE SAME OIL USED IN CRANKCASE EVERY 25 HOURS OF OPERATION.

PREVENTIVE MAINTENANCE CHART

FREQUENCY	PART	CARE
Before each use:	Engine Crankcase	Check oil level. Add as needed.
After first 5 hours of use:	Check Drive Chain tension and tighten if necessary. Check every 25 hours.	
	Engine Crankcase	Change Oil.
Every 25 hours of use or sooner as needed:	Steering Wheel Shaft	Oil steering mounting bracket.
	Engine Crankcase	Change oil.
	Rear Wheel Bearings	Oil.
	Front Wheel Bearings	Oil.
	Drive Chain	Oil.
	Linkage & Pivot Points	Oil all locations.
	Engine Air Cleaner	Clean and re-oil.
Before storage:	Tires	Check pressure, 12 to 15 pounds each.
	Engine	Drain gasoline tank & carburetor. Oil cylinder.
Beginning of season:	All points listed above.	

STORAGE

The riding mower should be immediately prepared for storage at the end of the season or if it is to be un-used for 30 days or more. **Gasoline, if permitted to stand un-used for extended periods (30 days or more), may develop gummy deposits which can adversely affect the engine carburetor and cause engine malfunction.**

⚠ DANGER ⚠

Never store engine with fuel in tank indoors or in enclosed, poorly ventilated enclosures, where fuel fumes may reach an open flame, spark or pilot light as on a furnace, water heater, clothes dryer, etc.

Handle gasoline carefully. It is highly flammable and careless use could result in serious fire damage to your person and/or property.

Drain fuel into an approved container outdoors, away from open flame.

To prepare riding mower for storage, proceed as follows:

1. Clean the riding mower thoroughly.
2. Inspect the riding mower for worn or damaged parts and tighten all loose screws and nuts.
3. Drain fuel from tank and run engine until it stops due to lack of fuel.
4. While engine is still warm, change crankcase oil as instructed in **To Change Engine Oil** paragraph in **Maintenance** section of this manual.
5. Remove spark plug and pour one (1) ounce of engine oil through spark plug hole into cylinder. Crank engine several times to distribute oil. Reinstall spark plug.
6. Lubricate all points shown in **Lubrication Chart**.
7. Store the riding mower in a clean, dry area and cover for additional protection.

A yearly check-up or tune-up by a qualified repairman is a good way of insuring that your riding mower will provide maximum performance for the next season.

The following **Trouble Shooting Guide** (2 pages) is designed to apply to all riding type mowers manufactured by Western International Incorporated. Some of the problems and corrections will not apply to your unit.

TROUBLE SHOOTING GUIDE	
DANGER: ALWAYS DISCONNECT SPARK PLUG WIRE BEFORE ATTEMPTING ANY INSPECTION OR ADJUSTMENT.	
PROBLEM	CORRECTION
Mower Cuts Ragged or Uneven	<ol style="list-style-type: none"> 1. Make certain blades are sharp and in good condition (not bent or incorrectly mounted). 2. Check blade mounting screw(s). Blade screw(s) must be tight. 3. Check quill assembly(s) for damage or bearing wear. Replace if necessary. 4. Remove any accumulation of grass clippings from underside of mower deck housing. 5. Check for possible damage to mower deck housing. Repair or replace if necessary. 6. Check pivot tube assembly for damage. If bent or damaged, repair or replace.
Mower Leaves Unmowed Strip Between Blades	<ol style="list-style-type: none"> 1. Check for worn or dull blades. Replace if necessary. 2. Check quill assembly(s) and make certain none are bent. Replace if necessary. 3. Mowing a heavy stand of grass or grass with excessive surface moisture could allow mower to leave a unmowed strip. Mow counterclockwise (side discharge only). Do not mow wet grass. 4. Forward speed should be adjusted to mowing conditions by gear selection. Engine should be run at full throttle. 5. Check blade belt tension. Adjust if necessary. 6. Check for damage to mower deck housing. Repair or replace if necessary.
Mower Scalps Lawn	<ol style="list-style-type: none"> 1. Check for bent blade(s) or quill assemble(s). Replace if necessary. 2. Check mower height adjustment setting and readjust if needed. Scalping is more likely on rough or uneven lawns. 3. Check mower deck leveling adjustment and readjust if necessary.
Mower Will Not Discharge Clippings	<ol style="list-style-type: none"> 1. Check underside of mower deck housing for accumulation of clippings. Remove accumulated clippings. 2. Wet conditions can cause the discharge chute and underside of mower deck to become plugged with clippings. Do not mow wet grass. 3. If blade(s) have been replaced, make sure they have been correctly mounted.
Collector Bag Does Not Billow Out as Usual	<ol style="list-style-type: none"> 1. Check collector discharge chute and bag inlet opening for plugging. 2. Check collector fan and jackshaft belts for tension and/or damage. Replace if necessary. 3. Check for split or damaged pulley(s). Replace if necessary.
Unit is Not Picking Up Grass Properly	<ol style="list-style-type: none"> 1. Check collector discharge chute, mower discharge chute and bag inlet opening for plugging. 2. Mower deck height may be too low and not allowing enough air flow. Raise cutting height. 3. Check collector fan and jackshaft belts for tension and/or damage. Replace if necessary. 4. Check for split or damaged pulley(s). Replace if necessary. 5. Check collector fan housing for grass clippings build-up. Clean fan housing. 6. Check mower deck for grass clippings build-up. Clean mower deck.
Sound Level of Fan is High	<ol style="list-style-type: none"> 1. Remove collector discharge chute and check fan housing for build up of grass clippings. Clean inside of fan housing.
Blade Drive Belt Comes Off During Use	<ol style="list-style-type: none"> 1. Check belt tension. Adjust if necessary. 2. Check all belt guides. Correct clearance is 1/16 inch from belt when blade engage lever is engaged. 3. Make certain mower deck leveling adjustment is correct. Adjust if necessary. 4. Check for and remove any foreign objects interfering with belt travel. 5. Check all pulleys on mower deck. A bent or split pulley could cause problems. Replace if necessary. 6. Check engine drive pulley inner surface. If inner surface is rough or split, pulley should be replaced. 7. Check blade throw-out assembly for wear. Replace necessary parts.
Blade Drive Belt Slips	<ol style="list-style-type: none"> 1. If grass is too high or wet, belt slippage may occur. 2. Check belt for wear or damage. Replace if necessary. 3. Check belt tension. Adjust if necessary. 4. Check blade drive belt tension spring. If spring is stretched or damaged, replace spring.
Blade Drive Belt Wears Excessively	<ol style="list-style-type: none"> 1. Check all belt guides. Correct clearance is 1/16 inch from belt when blade engage lever is engaged. 2. Check for and remove any foreign objects interfering with belt travel. 3. Check pulleys for damage. Replace if necessary. 4. Make certain belt brake is clearing belt when mower is engaged. If brake cable is too long or broken, adjust or replace. 5. Make certain mower deck leveling adjustment is correct. Adjust if necessary.
Blade(s) Will Not Engage	<ol style="list-style-type: none"> 1. Check belt. If worn or broken, replace. If belt is too loose, make belt adjustment. 2. Check engagement spring on deck engagement idler. If broken or damaged, replace. 3. Check for and remove any foreign objects interfering with engagement idler travel.
Blade(s) Will Not Disengage	<ol style="list-style-type: none"> 1. Check belt tension. Adjust if necessary. 2. If blade drive belt adjustment will not provide enough slack in drive belt, replace with correct Original Equipment Belt. 3. Check for and remove any foreign objects interfering with engagement idler travel.
Extreme Vibration Occurs When Blade is Engaged	<ol style="list-style-type: none"> 1. Check blade(s) and make certain they are not bent, out of balance or loose. Replace if necessary. 2. Check belt for burn spots or irregularities that might cause vibration. Replace if necessary. 3. Check quill assembly(s) for damage or wear. Replace if necessary. 4. Check for worn or damaged blade engagement parts. Repair or replace as necessary. 5. Check engine drive pulley inner surface. If inner surface is rough or split, pulley should be replaced. 6. Check under side of mower deck housing for accumulation of clippings. Remove accumulated clippings. 7. Check for loose or damaged engine mounts. Tighten or replace as necessary.

TROUBLE SHOOTING GUIDE (Continued)

DANGER ALWAYS DISCONNECT SPARK PLUG WIRE BEFORE ATTEMPTING ANY INSPECTION OR ADJUSTMENT.

PROBLEM	CORRECTION
Deck or Deck Wheel Hits Rear Wheel and Tire Assembly	<ol style="list-style-type: none"> 1. Deck drive belt adjustment is too tight. Readjust. 2. Other than Original Equipment Belt is being used and is either too long or stretched. Replace belt. 3. Belt is worn. Replace with new Original Equipment Belt. 4. Check pivot tube assembly for damage. Repair or replace if necessary.
Deck Lift Cable Broken	<ol style="list-style-type: none"> 1. Check operating procedure. Excessive ground speed on rough lawn may cause mower deck bounce, resulting in lift cable failure. 2. Remove excessive clippings from underside of mower deck housing (build-up of clippings adds excessive weight to mower deck).
Unit Drive Belt Slips	<ol style="list-style-type: none"> 1. Check unit drive belt adjustment(s). Adjust if necessary. 2. Check for damaged or broken clutching idler spring. Replace if necessary. 3. Check belt(s) for wear or damage. Replace if necessary. 4. Check vari-speed control lever adjustment. 5. Check for and remove any foreign objects obstructing vari-speed or clutching idler mechanism.
Unit Drive Belt Squeals When Brake is Applied	<ol style="list-style-type: none"> 1. Check brake-clutch synchronization (does not apply to vari-speed units). Adjust if necessary. 2. Check unit drive belt adjustment(s). Adjust if necessary. 3. Check for and remove any foreign objects obstructing vari-speed or clutching idler mechanism. 4. Check brake adjustment.
Unit Drive Belt Comes Off During Use	<ol style="list-style-type: none"> 1. Check belt tension. Adjust if necessary. 2. Check belt guides. Adjust if necessary. 3. Check for split or damaged pulley(s). Replace if necessary. 4. Check clutching idler pulley alignment. If out of alignment, idler bracket may be bent. Replace if necessary.
Jackshaft Drive Belt Comes Off During Use	<ol style="list-style-type: none"> 1. Check idler support brackets and tighten if loose. 2. Check to make sure belt has proper twist so that "V" side of belt is in grooves on all four pulleys. 3. Check spring on right idler pulley for damage. Replace if necessary. 4. Adjust left idler pulley if belt is loose. 5. Check for worn or damaged belt. Replace if necessary.
Unit Will Not Propell Itself When Clutch or Vari-Speed Lever is Engaged	<ol style="list-style-type: none"> 1. See Steps 1 through 5 in Unit Drive Belt Slips section of this chart. 2. Check engine, transmission or transaxle pulley(s) for sheared or missing key. Replace if necessary. 3. Check transmission or transaxle to make certain it is operable. Make certain chain (chain drive units only) is intact.
Extreme Vibration Occurs When Clutch is Engaged (Let-Out)	<ol style="list-style-type: none"> 1. Check for split or damaged pulley(s). Replace if necessary. 2. Check belt for irregularities or burned spots. Replace if necessary. 3. Make certain belt tension is correct. Adjust if necessary. 4. Check clutching idler assembly for wear or damage. Replace parts as necessary. 5. On chain drive units, check sprockets for proper alignment and chain damage. Replace if necessary. 6. Check for loose or damaged engine mounts. Tighten or replace as necessary. 7. Check collector fan bearing. Replace damaged or worn bearing. 8. Check collector fan mounting and number (4) of fan blades. Replace fan if necessary. 9. Check collector fan blades for bends or unusual wear which could affect balance.
Unit Will Not Shift or Shifts Hard	<ol style="list-style-type: none"> 1. Check shifting procedure. Unit MUST come to a complete stop before shifting. On vari-speed units, hold firm pressure on shift lever while moving vari-speed control lever slowly forward. 2. Check brake-clutch synchronization (does not apply to vari-speed units). Adjust if necessary. 3. Check unit drive belt adjustment. Adjust if necessary. 4. Have transmission or transaxle checked by a competent repairman.
Steering Slips or is Loose	<ol style="list-style-type: none"> 1. Check for steering sector gear and pinion looseness. If gears are loose, make sector gear adjustment. 2. Check ball joints for wear. Replace if necessary. 3. Check center pivot bolt on front axle. If loose, tighten securely.
Engine Will Not Turn Over	<ol style="list-style-type: none"> 1. Check starting procedure. Make sure starting instructions are followed. 2. Check fuse (if so equipped). 3. Check battery for charge. Make sure battery has been activated (on new units). 4. On new units, remove spark plug and check cylinder for accumulation of oil due to handling. 5. Make visual check of electrical system to make sure all connections and lockout switches are secure. 6. Check engine according to engine manufacturers instructions. 7. Have electrical system checked by a competent repairman.
Engine Turns Over But Will Not Start	<ol style="list-style-type: none"> 1. Check starting procedure. Make sure starting instructions are followed. 2. Make certain fuel tank is filled with clean, fresh gasoline. 3. Make certain fuel shut-off is open (if so equipped). 4. Make certain that throttle is in choke or fast position. 5. Check engine according to engine manufacturers instructions. 6. On recoil start unit, make visual check of wiring system to make sure all connections and lockout switches are secure. 7. Have wiring and lockout switches (on recoil start unit) checked by a competent repairman.

REPAIR PARTS

26" RIDING MOWER MODEL 2650-0200

ALWAYS GIVE THE FOLLOWING INFORMATION WHEN ORDERING REPAIR PARTS:

1. The PART NUMBER; 2. The PART NAME; 3. QUANTITY DESIRED; 4. The MODEL NUMBER (As shown on Model Plate)

SEND PART ORDERS AS PER INSTRUCTIONS ON THE FRONT PAGE

YOUR UNIT IS RIGHT HAND (RH) OR LEFT HAND (LH) AS YOU STAND BEHIND IT.

DO NOT USE KEY NUMBERS WHEN ORDERING REPAIR PARTS, ALWAYS USE PART NUMBERS.

All replacement parts will be supplied in current production colors or in a neutral color.

A handling fee is applicable to small parts orders.

Key No.	Part No.	Description
1	995363	Screw, Hex Hd, No. 10-32 x 5/8 In.
2	27521	Clip, Throttle Control
3	Engine	§See footnote below
4	120638	Lockwasher, Split, 5/16 In.
5	9413447	Locknut, 5/16-18 Thd
6	55452	Quadrant
7	55621	Grip
8	35497	Screw, Tapite, 5/16-18 x 1/2 In.
9	54686	Screw, Nylock, 1/4-28 x 3/4 In.
10	120380	Lockwasher
11	9421393	*Flatwasher, 9/32 In.
12	50618	Spacer
13	55487	Plate, Spring
14	Transmission	†Peerless, Model 757-A
15	122119	*Screw, Hex Hd, 3/8-16 x 3/4 In.
16	120228	Screw, Hex Hd, 5/16-18 x 5/8 In.
17	70405	Decal, Caution
18	55658	Guide, Mower Deck
19	122040	*Screw, Hex Hd, 5/16-18 x 1 1/2 In.
20	126211	*Carriage Bolt, 5/16-18 x 5/8 In.
21	55465	Main Frame
22	55461	Clutch Rod
23	9413534	Locknut, 3/8-16 Thd
24	35410	Spring, Idler
25	21882	Spacer
26	122017	Screw, Hex Hd, 5/16-18 x 1 In.
27	122007	*Screw, Hex Hd, 5/16-18 x 3/4 In.
28	138485	Washer, Shakeproof, 5/16 In.
29	55464	Channel, Stiffener
30	3021	Key, Woodruff No. 606
31	55455	Pulley, Transmission
32	55450	V-Belt
33	22053	Retaining Ring
34	33200	Key, Square, 1/4 x 1/4 x 1 1/2 In.

Key No.	Part No.	Description
35	55477	Pulley, Engine
36	120382	Lockwasher, Split, 3/8 In.
37	120758	*Screw, Hex Hd, 3/8-24 x 7/8 In.
38	55480	Belt Guide
39	446363	Flatwasher
40	48253	Flatwasher, 5/8 In.
41	55467	Arm, Idler
42	41890	Shoulder Bolt
43	45892	Carriage Bolt, 3/8-16 x 1 1/2 In.
44	274517	*Flatwasher, 13/32 In.
45	39659	Retainer, Belt
46	35374	Pulley, Idler
47	55448	Brake Arm
48	456713	Roll Pin
49	120386	*Flatwasher, 5/16 In.
50	55447	Pin, Brake Anchor
51	40394	Hub Cap, Rear
52	36625	Retaining Ring
53	42815	Flatwasher, 3/4 In.
54	47596	Bracket, Bearing Retaining
55	35345	Bearing, Self-Aligning
56	55463	Brace, Brake Pin
57	55449	Band, Brake
58	54952	Drum, Brake
59	20307	Link, Connector
60	55456	Sprocket, 45 Tooth
61	55491	Chain Assembly
62	52631	Differential
63	642	Flatwasher, 3/4 In.
64	52823	Spacer, Differential
65	39628	Key, Square
66	271184	*Nut, Keps, 5/16-18 Thd
67	46551	Wheel & Tire Assy., Rear
68	24167	Valve Stem
69	62890	Owner's Manual (Not Illustrated)

*Standard Hardware Items - May Be Purchased Locally.

†Contact Tecumseh/Peerless' authorized service dealer for parts and warranty.

§Contact Engine Manufacturer's authorized service dealer (See Engine Manual) for parts and warranty.

26" RIDING MOWER MODEL 2650-0200

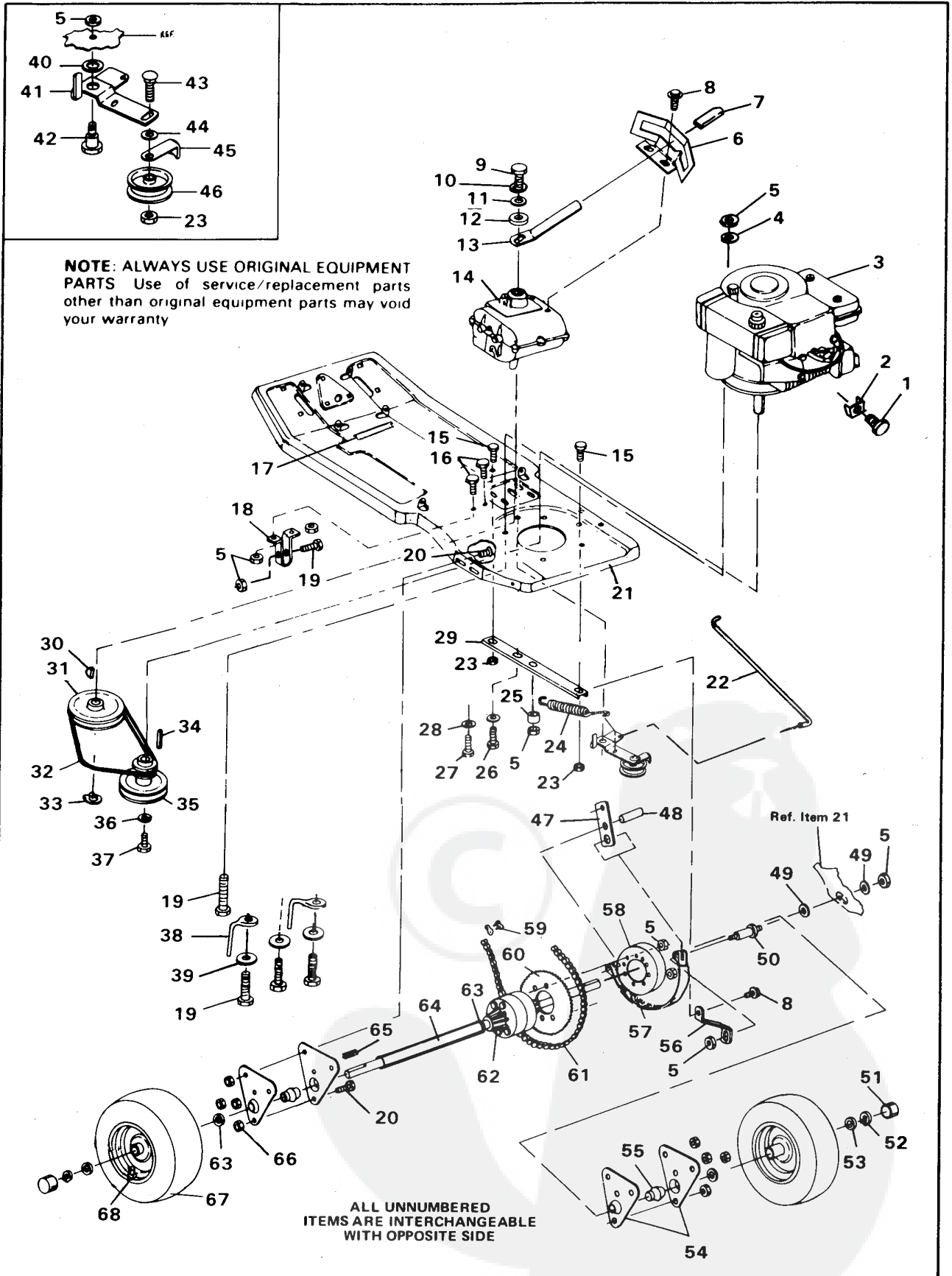

26" RIDING MOWER MODEL 2650-0200

Key No.	Part No.	Description
1	52955	Wheel, Steering
2	456836	Roll Pin, 1/4 x 2 1/4 In.
3	51858	Tube, Steering, Decorative
4	52952	Shaft, Steering
5	9417375	Pin, Spiral, 3/16 x 1 1/2 In.
6	52953	Shaft, Steering
7	70092	Decal, Console
8	55454	Console Assembly
9	40886	Screw, Taptite, 1/4-20 x 3/8 In.
10	48901	Screw, Hex Hd, 5/16-18 x 5/8 In.
11	55490	Pad, Footrest, R.H.
12	55445	Support, Steering
13	126211	*Carriage Bolt, 5/16-18 x 5/8 In.
14	55489	Pad, Footrest, L.H.
15	9424215	Locknut, 1/4-20 Thd
16	44112	Bracket, Clutch/Brake
17	120393	*Flatwasher, 11/32 In.
18	8260	Hairpin Cotter
19	9413447	Locknut, 5/16-18 Thd
20	44582	Nut, Push, 7/16 In.
21	52840	Pad, Clutch/Brake Pedal
22	51833	Lever Assembly, Clutch/Brake
23	47601	Lever, Parking Brake
24	3275	Shoulder Bolt
25	122119	*Screw, Hex Hd, 3/8-16 x 3/4 In.
26	55459	Bracket, Deck Hanger
27	68644	Decal, Deck Hanger Bracket
28	20859	Retaining Ring
29	4107	Flatwasher, 5/8 In.
30	44111	Bearing, Flange
31	55466	Axle Assembly, Front
32	9413534	Locknut, 3/8-16 Thd

*Standard Hardware Items - May Be Purchased Locally.

Key No.	Part No.	Description
33	51805	"U" Bracket, Steering Shaft
34	35497	Screw, Taptite, 5/16-18 x 1/2 In.
35	47595	Spindle, L.H.
36	40677	Flatwasher, 5/8 In.
37	53618	Wheel & Tire Assy. w/Bearing
38	53619	Bearing, Front Wheel
39	36832	Hub Cap, Front
40	46511	Shoulder Bolt
41	3140	Wave Washer
42	120228	*Screw, Hex Hd, 5/16-18 x 5/8 In.
43	44151	Link, Steering
44	47594	Spindle, R.H.
45	39522	Pin, Clevis
46	55460	Bracket, Clutch Rod
47	271172	*Nut, Keps, 1/4-20 Thd
48	55462	Brake Rod
49	55485	Fender, L.H.
50	55486	Fender, R.H.
51	70095	Decal, Shift Pattern
52	44121	Eye Bolt, 3/8-16 x 3 1/2 In.
53	120377	*Nut, Hex, 3/8-16 Thd
54	122007	*Screw, Hex Hd, 5/16-18 x 3/4 In.
55	52845	Support, Seat
56	122027	*Screw, Hex Hd, 5/16-18 x 1 1/4 In.
57	120638	*Lockwasher, Split, 5/16 In.
58	46905	Control, Throttle
59	35287	Screw, Taptite, No. 8-32 x 3/8 In.
60	39486	Knob, Throttle Control
61	55484	Support, Seat
62	122017	*Screw, Hex Hd, 5/16 x 1 In.
63	55981	Seat
64	120386	Flatwasher
65	45174	Locknut, Wide Flange, 5/16-18 Thd.
66	120834	*Screw, Hex Hd, 5/16-18 x 1/2 In.



26" RIDING MOWER MODEL 2650-0200

NOTE: ALWAYS USE ORIGINAL EQUIPMENT PARTS. Use of service/replacement parts other than original equipment parts may void your warranty.

ALL UNNUMBERED ITEMS ARE INTERCHANGEABLE WITH OPPOSITE SIDE

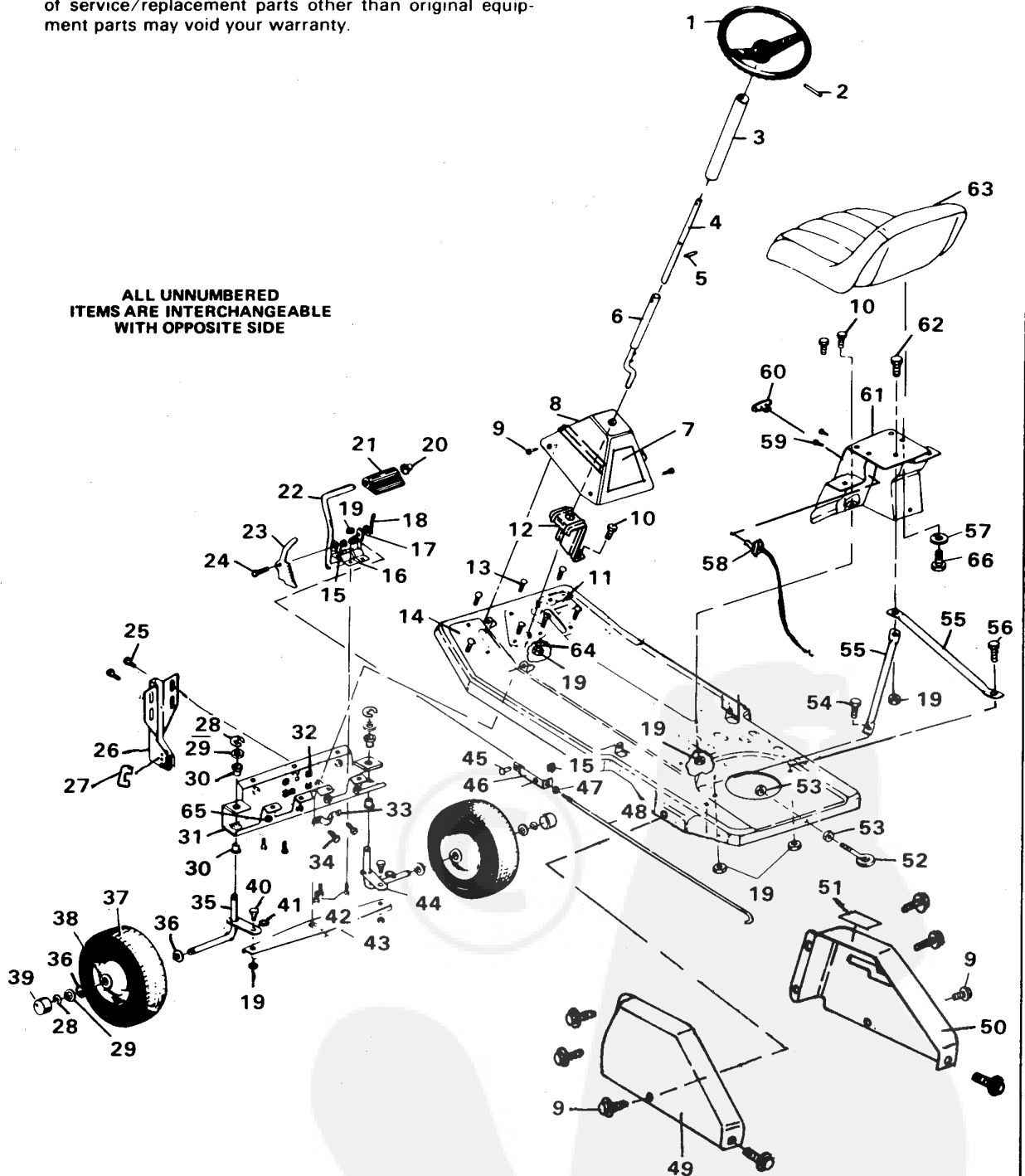

26" RIDING MOWER MODEL 2650-0200

Key No.	Part No.	Description	Key No.	Part No.	Description
1	47816	Pull Pin	41	56623	Saddle & Shaft Assembly
2	44848	Spacer	42	35410	Spring, Brake
3	996416	Flatwasher	43	45074	Pulley, Idler
4	120394	*Flatwasher, 3/8 In.	44	274517	Flatwasher
5	56180	Hairpin Cotter	45	121222	*Cotter Pin, 3/32 x 3/4 In.
6	45536	Hitch Bar	46	52209	Shoulder Bolt
7	55689	Lift Cable Assembly	47	55619	Spring, Mower Clutch
8	45537	Bracket, Pivot	48	39659	Belt Retainer
9	122201	Screw, Hex Hd, 3/8-16 x 2 3/4 In.	49	55495	Arm Assembly, Idler
10	120228	*Screw, Hex Hd, 5/16-18 x 3/8 In.	50	845	Flatwasher
11	45542	Bracket, Deck Front	51	41204	Switch, Safety
12	9413534	*Locknut, 3/8-16 Thd	52	43038	Wire Assy, Safety Switch
13	271172	Nut, Keps, 1/4-20 Thd	53	45877	Locknut
14	45533	Bracket, Cable	54	45878	Lockwasher
15	120372	*Nut, Square, 1/4-20 Thd	55	55622	Bracket, Safety Switch
16	120638	Lockwasher, Split	56	122168	Screw, Hex Hd, 3/8-16 x 1 3/4 In.
17	55618	Bracket, Rod	57	43926	Mower Deck
18	271184	*Locknut, Keps, 5/16-18 Thd	58	41482	Wire Clip, Press
19	55481	Belt Guide	59	20250	Grip, Hand
20	55442	Belt	60	122017	Screw, Hex Hd, 5/16-18 x 1 In.
21	446363	Washer	61	45602	Washer
22	44132	Bracket Assy, Clutch Lever	62	50634	Screw, Taptite, 5/16-18 x 7/8 In.
23	3057	Knob	63	55476	Blade, 26 In.
24	44144	Rod, Clutch	64	2483	Spring Washer
25	43950	Chute Deflector	65	39573	Screw, Hex Hd, 3/8-24 x 1 In.
26	70203	Decal, Danger	66	55478	Guide, Rear
27	56635	Nut, Hex, 15/32-32 Thd.	67	29194	Shoulder Bolt
28	120706	*Screw, Hex Hd, 1/4-20 x 1/2 In.	68	45406	Shoulder Bolt
29	9424215	*Locknut, Hex, 1/4-20 Thd	69	120382	*Lockwasher, Split, 3/8 In.
30	67475	Decal, Height Adjust	70	45539	Tube Assy, Height Adjust
31	9413447	*Locknut, Hex, 5/16-18 Thd	71	45540	Quadrant, Height Adjust
32	56282	Quill Assy. (Incl. Nos. 33-41)	72	271190	*Locknut, Keps, 3/8-16 Thd
33	51445	Locknut, Flange, 7/16-20 Thd	73	52584	Wheel
34	56365	Flatwasher	74	23763	Shoulder Bolt
35	56390	Pulley	75	45434	Shoulder Bolt
36	56280	Spacer	76	42694	Spring
37	49562	Bearing	77	39119	Shoulder Bolt
38	50818	Spacer, Tube	78	45541	Lever, Height Adjust
39	55547	Quill Housing	79	45905	Locknut, Wide Flange, 3/8-16 Thd.
40	50616	Dust Shield			

*Standard Hardware Items - May Be Purchased Locally.

26" RIDING MOWER MODEL 2650-0200

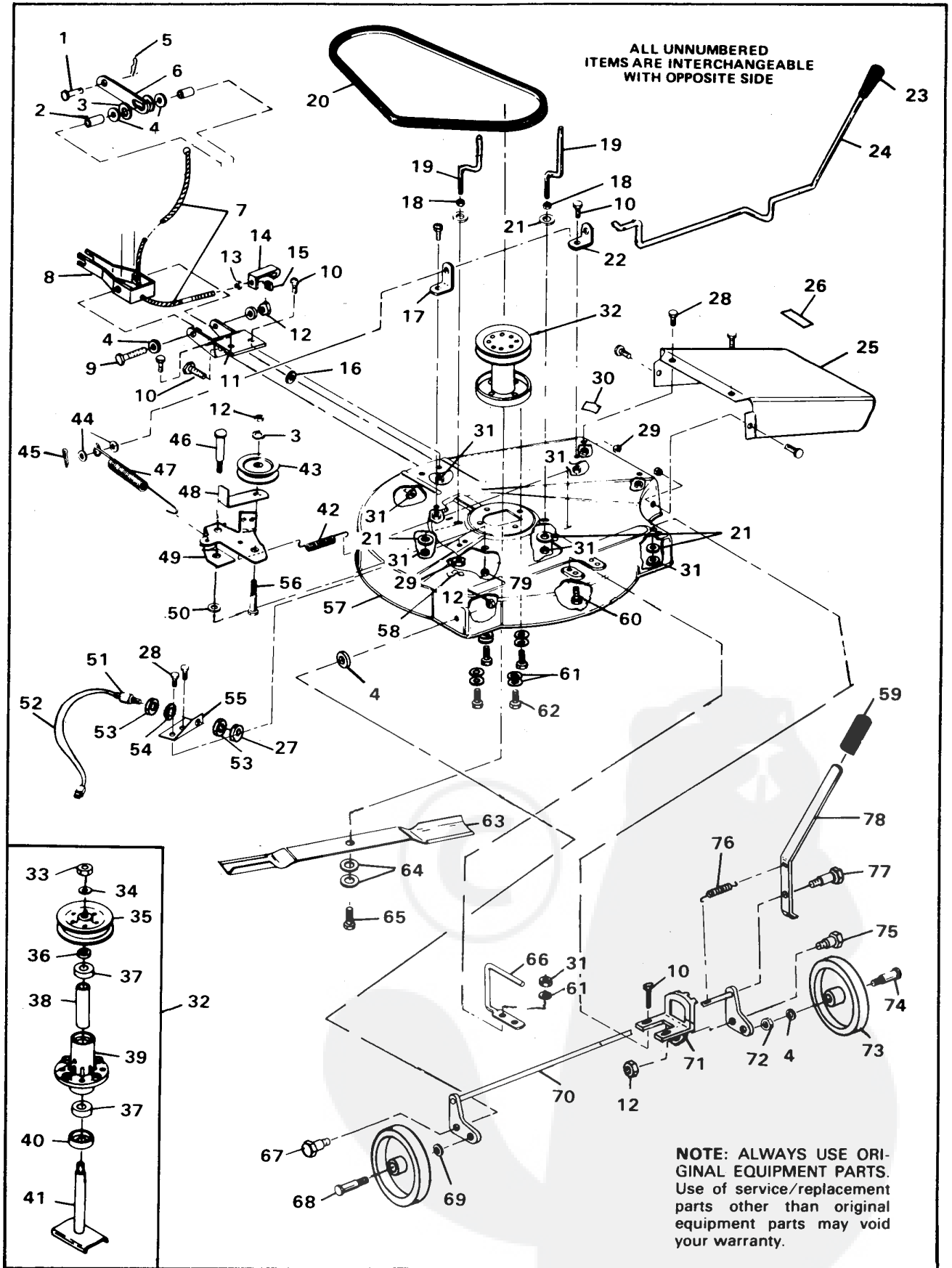

26" RIDING MOWER MODEL 2650-0200

Key No.	Part No.	Description
1	49643	Key, Ignition
2	48140	Nut (Ignition Switch Part)
3	138557	Lockwasher (Ignition Switch Part)
4	46376	Switch, Ignition
5	35287	Screw, Taptite, No. 8-32 x 3/8 In.
6	55474	Control Module
7	56635	Nut, Hex, 15/32-32 Thd.
8	55473	Wire Assembly
9	45878	Lockwasher (Lockout Switch Part)
10	45877	Locknut (Lockout Switch Part)
11	41204	Switch, Lockout, Mower Deck
12	42071	Wire Assembly, By-Pass
13	43038	Wire Assembly, Deck Switch

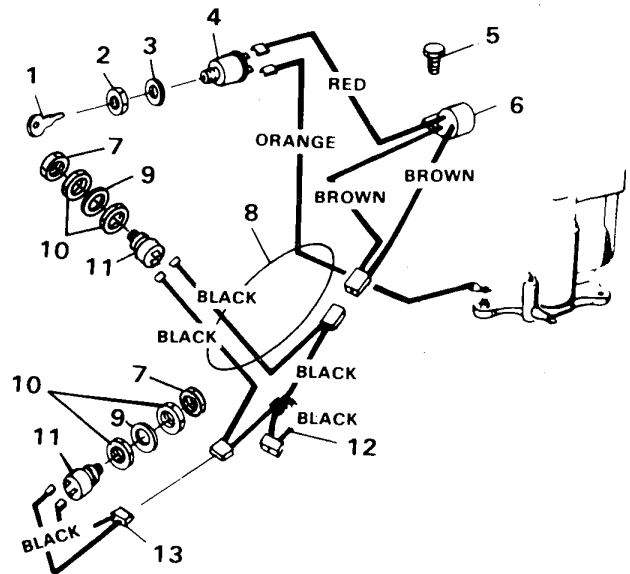

NOTE: ALWAYS USE ORIGINAL EQUIPMENT PARTS. Use of service/replacement parts other than original equipment parts may void your warranty.

SEE, CALL OR WRITE ONE OF THE FOLLOWING DISTRIBUTORS FOR PARTS FOR: HOMKO - LAWN SCOUT - AMF - TURFMASTER - DYNAMARK - OR ANY OTHER WESTERN INTERNATIONAL INCORPORATED PRODUCT.

ALABAMA

Automotive Elect. Service, 415 Meridian St., Huntsville, AL 35801, (205) 539-2131, AL WATS 800-536-3394 *b,c,f,g,h
Warlick-Miller A/C Eng., 630 N. 20th St., Bessemer, AL 35020, (205) 424-8288, AL WATS 800-292-8123
 MS WATS 800-292-4494 *b,c,f,g,h

CALIFORNIA

Billiou's, 75 No. D, Porterville, CA 93257, (209) 784-4102 *b,c,f,g,h
The Lawn Mower Shop, 1340 El Camino Real, San Carlos, CA 94070, (415) 593-4716 *a,d,f,g

COLORADO

Spitzer Ind. Prod. Co., 6601 N. Washington, Thornton, CO 80229, (303) 287-3414 *b,d,h

FLORIDA

G.L.O. Products Inc., 13201 Belcher Rd. S., Largo, FL 33543, (813) 530-9723 *a,c,h

Radco Distributors Inc. 4909 Victor St., Box 5459, Jacksonville, FL 322070459, (904) 733-7957 *a,c,f,g,h

ILLINOIS

Cox Tire & Battery, 603 N. Market, Marion, IL 62959, (618) 993-2607 IL WATS 800-642-4351 *a,c,f,g,h
Garmoe Distr. Inc., 2620 N. Mannheim Road, Franklin Park, IL 60131, (312) 455-3588 *a,c,f,g,h
Small Engine Parts, 3515 Auburn St., Rockford, IL 61103, (815) 964-1754 *b,c,f,g,h

INDIANA

Thompson Sales & Service, 2400 W. Ridge Road, Gary, IN 46408, (219) 980-3282 *a,b,c,f,g,h

IOWA

Bruce Engine, 1829 N.W. 86th, Des Moines, IA 50322, (515) 278-5151 *a,c,f,g,h

KANSAS

Colladay Hdwe. Co., 201 N. Plum, Box 766, Hutchinson, KS 67501, (316) 663-4477 *a,c

KENTUCKY

Auto-Electric Inc., 715 W. Hwy 80, Box 671, Somerset, KY 42501, (606) 679-1171 *c,f,g,h

Cayce Mill Supply Co., 1st & Douglas St., Hopkinsville, KY 42240, (502) 886-3335 *f,g,i

Ellingsworth Auto Electric, 1003-08 E. Broadway, Louisville, KY 40204 (Serving Southern Indiana), (502) 585-5055, KY WATS (800) 722-5061 *b,c,f,g,h

LOUISIANA

United Engine Service, Inc., 11923 Cloverland Ave., Baton Rouge, LA 70809, (504) 291-2622 *a,d,f,g,h

MARYLAND

Center Supply Co., 6867 New Hampshire Ave., Takoma Park, MD 20912, (301) 270-1690 *b,c,f,g,h

Kunkel Service Co., 6252 Frankford Ave., Baltimore, MD 21206, (301) 377-4008, MD WATS 800-492-8886 *b,c,f,g,h

MASSACHUSETTS

Morton B. Collins Co., 300 Birnie Ave., Box 70058, Springfield, MA 01107, (413) 732-7449 *a,c,g,h

Crandall-Hicks Co., 250 Eliot St., Ashland, MA 01721, (617) 881-6122 *a,d

MICHIGAN

Air Cooled Engine Div., 615 First St., Menominee, MI 49858, (906) 863-8011, MI WATS (906 area only) 800-562-4825 *a,c,f,g,h

Heat Engineering Inc., 7700 Southfield Road, Detroit, MI 48228, (313) 271-7550 *a,c,f,g,h

Lorenz Service Co., 2500 S. Pennsylvania Ave., Lansing, MI 48910, (517) 484-1361 *b,c,f,g,h

MINNESOTA

Northern Automotive Co., 1401 W. Broadway, Minneapolis, MN 55411, (612) 522-6656 *a,c,f,g,h

MISSISSIPPI see Bessemer, Alabama

MISSOURI

Gunther's Service & Supply, 7320 Wor-nall Road, Kansas City, MO 64114, (816) 523-1952 *a,f,g,h

Wilson Engine & Parts Inc., 4159 Shoreline Drive, Jct. I-70 & 270, Earth City, MO 63045, (314) 739-1313, MO WATS 800-392-4063, WATS (outside MO only) 800-367-2787 *a,b,d,f,g,h

NEW JERSEY

Power Distributors, Inc., 102 Mayfield Ave., Edison, NJ 08837, (201) 225-4922 *j

NEW YORK

Loegler & Ladd Inc., 3950 Broadway, Box 214, Buffalo, NY 14225, (716) 684-0600 *a,c

Stiefvater Distr. Inc., Clinton Road, Route 12B, New Hartford, NY 13413, (315) 853-5581 *a,c,f,g,h

NORTH CAROLINA

Carswell Distr. Co., 3750 N. Liberty St., Box 4193, Winston-Salem, NC 27105, (919) 767-7700 *g,i

Dixie Sales Co., Inc., 335 N. Green, Box 1408, Greensboro, NC 27402, (919) 274-0490, NC WATS 800-632-1276 *b,c,f,g,h

OHIO

American Power Distr., 2430 Tremains-ville Rd., Box 8515, Toledo, OH 43613, (419) 475-7261 *f,g,h

Small Engine Distr., 5250 N. Dixie, Box 1481, Dayton, OH 45414, (513) 278-8241 *b,f,g,h

OKLAHOMA

Albro's, 2921 W. Hefner Rd., Oklahoma City, OK 73120, (405) 751-1711 *a,c,f,g,h

PENNSYLVANIA

Bluemont Co., 11101 Frankstown Road, Pittsburg, PA 15235, (412) 242-2522 *a,b,c,f,g,h

Scranton Auto Ignition, 1133 Wyoming Ave., Scranton, PA 18509, (717) 342-8133 *b,c,f,g,h

SOUTH CAROLINA

Magneto & Elect. Service, 103 Assembly St., Columbia, SC 29201, (803) 771-4044, SC WATS 800-922-1118 *a,c,f,g,h

TENNESSEE

American Sales & Serv., 3035 Bellbrook Dr., Memphis, TN 38116, (901) 332-2210 *a,d,f,g,h

Chilton A/C Engines, 319 4th Ave. S., Box 15806, Nashville, TN 37201, (615) 254-1634 *b,c,f,g,h

Ace Distr., Inc., 2103 E. Magnolia Ave., Box 3587, Knoxville, TN 37917, (615) 524-5359, TN WATS 800-332-9904 *a,c,f,g,h

TEXAS

Marr Bros. Inc., 423 E. Jefferson, Dallas, TX 75203, (214) 948-7387 *a,c,f,g,h

Midland Small Engine Sales, 106 Carlton, Box 4215, Midland, TX 79704, (915) 682-1409 *b,f,g,h

VIRGINIA

Norva Small Engines, 8120 E. Wellington Rd., Manassas, VA 22110, (703) 369-3387 *a,c,f,g,h

RBI Corporation, 101 Cedar Ridge Rd., Lakeridge Park, Ashland, VA 23005, (804) 798-1535 *a,c,f,g,h

WASHINGTON

Pacific A/C Engine Inc., 4030 1st Ave. S., Box 84783, Terminal Annex, Seattle, WA 98124, (206) 682-4677 *a,c,f,g,h

WEST VIRGINIA

Interstate Radiator, 1611 4th Ave., Charleston, WV 25312, (304) 345-1724 *a,d,f,g,h

WISCONSIN

Reliable Hdwe., 8010 N. 76th St., Milwaukee, WI 53223, (414) 355-2900 *b,c,f,g,h

Wiggert Brothers, 3rd & Jay, Box 1267, La Crosse, WI 54601, (608) 784-4790 *a,b,c,f,g,h

CANADA

Suntester Equipment Ltd., 5466 Timberlea Blvd., Mississauga, Ontario, Canada L4W 2T7, (416) 624-6200 *g,i

Yetman's Ltd., 949 Jarvis Ave., Winnipeg, Manitoba, Canada R2X 0A1, (204) 586-8046, WATS (Manitoba & Sask.) 800-665-8623 *b,c,f,g

Revised 1/20/86

(*) General Information Codes:

- (a) Advance Payment Preferred
- (b) Accepts Credit Cards
- (c) C.O.D. okay
- (d) No. C.O.D.
- (e) C.O.D. only
- (f) Briggs & Stratton dealer or distributor
- (g) Tecumseh/Peerless dealer or distr.
- (h) Foote dealer or distributor
- (i) Dealer sales only, contact for closest dealer.