

**OWNER'S MANUAL**  
**36" - 11 H.P. RIDING MOWER**  
**MODEL 3560-91**

**WARRANTY**

**ONE YEAR LIMITED WARRANTY**

For one (1) year from date of purchase by the first consumer for residential use (thirty (30) days commercial use), Western International Incorporated warrants that it will replace free of charge, including labor, any original part of any Western International Incorporated product found to be defective by any authorized Service Dealer or the factory, except the battery which is warranted for ninety (90) days from date of purchase.

This warranty does not cover engine, transmission, transaxle or differential (these items are covered by their manufacturer's own warranty). This warranty does not cover parts that have failed due to normal wear or parts that have failed subject to misuse or abuse. Transportation of the unit or part to and from an authorized Service Dealer or the factory is the responsibility of the owner.

A step by step explanation as to what procedure should be followed for this Warranty is:

1. If a part becomes defective, contact the store where the unit was purchased for the name and address of the authorized Service Dealer nearest to you.
2. If you cannot locate an authorized Service Dealer, write Service Department of Western International Incorporated for the name and address of the authorized Service Dealer in your area or call the Service Department at 1-515-265-3461.
3. Return the defective product, along with proof of purchase to such authorized Service Dealer for replacement of any defective part where covered by this warranty.

There is no other express warranty. Implied warranties, including those of merchantability and fitness for a particular purpose are limited to one (1) year from date of purchase. Liability for incidental or consequential damages are excluded.

Some states do not allow limitations on how long an implied warranty lasts, so the above limitation may not apply to you. Some states do not allow the exclusion of incidental or consequential damages, so the above exclusion may not apply to you. This warranty gives you specific legal rights, and you may have other rights which vary from state to state.

Western International Incorporated      P.O. Box 377      Des Moines, Iowa 50302

**UNIT PARTS AND SERVICE**

This manual contains instructions for safety, assembly and maintenance. Read this manual carefully and completely so that you will know proper assembly, use and care of your unit. Also fill in and mail the registration card packed with the unit. For service other than covered in this manual, contact an authorized service dealer. A nationwide parts and service organization has been established to provide locally available parts and service. A list of authorized parts distributors has been included in this manual. When ordering repair parts, always give the following information: 1. The Part Name; 2. The Part Number; 3. The Quantity desired; 4. The Full (eight digit) Model Number of the unit. The model number will be found on a plate attached to the unit.



Look for this symbol. It means - ATTENTION! BECOME ALERT! A HAZARD TO OPERATOR, BYSTANDERS, PROPERTY OR EQUIPMENT MAY EXIST.

WESTERN INTERNATIONAL INCORPORATED  
P.O. BOX 377  
DES MOINES, IOWA 50302

Part No. 301077

0588

Price \$2.00

Printed in U.S.A.



## OPERATIONAL PRECAUTIONS

THESE INSTRUCTIONS ARE FOR YOUR PROTECTION. PLEASE READ THEM CAREFULLY.



1. Know the controls and how to stop quickly. READ THIS OPERATOR'S MANUAL and instructions furnished with attachments.
2. Wear safety glasses or eye shields when assembling or operating riding mower.
3. Do not allow children to operate the machine. Do not allow adults to operate it without proper instruction.
4. Do not carry passengers. Do not mow when children and others are around. Disengage power to blade(s) or attachment(s) and stop the engine while others are in the vicinity of the mower.
5. Battery fluid (electrolyte) is an ACID and is extremely dangerous. Do not smoke while servicing the battery. Do not service battery near an open flame or spark.
6. Handle gasoline with care, it is highly flammable.
  - A. Use approved gasoline container.
  - B. Never remove the fuel cap of, or add gasoline to, a running or hot engine, or an engine that has not been allowed to cool for several minutes after running. Never fill the tank indoors and always clean up spilled gasoline immediately.
  - C. Do not smoke while filling fuel tank.
  - D. Do not run the engine indoors. Open doors if engine must be run in garage. Exhaust fumes contain CARBON MONOXIDE, an ODORLESS and DEADLY GAS.
7. Check fuel supply before each use allowing space for expansion as the heat of the engine and/or sun can cause gasoline to expand.
8. Do not operate mower when barefooted. Always wear substantial footwear, preferably steel-toed shoes. Do not wear loose fitting clothing that could get caught in moving parts.
9. Clear the work area of objects (wire, rocks, etc.) which might be picked up and thrown. Check all controls for proper function.
10. Disengage all attachment clutches, shift to neutral, and set parking brake before attempting to start the engine (motor). When starting engine equipped with a pull starter, stand firm and make sure your feet are well away from the blade(s).
11. Disengage power to blade(s) or other attachment(s) and stop the engine (motor) before leaving the operator's position. Always dismount from left side.
12. Disengage power to blade(s) or other attachment(s) and stop the engine (motor) before making any repairs or adjustments.
13. Disengage power to blade(s) or other attachment(s) when transporting or not in use.
14. Take all possible precautions when leaving the vehicle unattended, such as disengaging power to blade(s) or attachment(s), lower the attachment(s), setting the parking brake, stopping the engine (motor), and removing the key.
15. Do not stop or start suddenly when going uphill or downhill. Mow up and down the face of steep slopes; never across the face.
16. Reduce speed and exercise extreme caution on slopes and in sharp turns to prevent tipping or loss of control. Be especially cautious when changing direction on slopes.
17. Stay alert for holes, rocks, and roots in the terrain and other hidden hazards. Keep away from drop-offs. Never operate your riding mower on wet or slippery grass or at a speed which could cause a skid. Exercise care when mowing around a fixed object to prevent the blade(s) from striking it. Never deliberately run over any foreign object.
18. Always disengage blade control lever before attempting to remove the mower from a hole or other obstruction.
19. Use care when pulling loads or using heavy equipment.
  - A. Use only approved drawbar hitch points.
  - B. Limit loads to those you can safely control.
  - C. Do not turn sharply. Use care when backing.
  - D. Use counterweight(s), wheel weights or tire chains when suggested in attachment(s) instructions.
20. Watch for traffic when crossing or near roadways.
21. When using attachment(s), never direct discharge of material toward bystanders nor allow anyone near the vehicle while in operation.
22. Keep the vehicle and attachments in good operating condition, and keep safety devices in place and in working condition.
23. Keep all nuts, bolts, and screws tight to be sure the equipment is in safe working condition.
24. Never store the equipment with gasoline in the tank inside a building where fumes may reach an open flame or spark. Allow the engine to cool before storing in any enclosure.
25. To reduce fire hazard, keep the engine free of grass, leaves, or excessive grease.
26. The vehicle and attachments should be stopped and inspected for damage after striking a foreign object, and the damage should be repaired before restarting and operating the equipment.
27. Do not change the engine governor settings or overspeed engine.
28. When using the vehicle with mower, proceed as follows:
  - A. Mow only in daylight or in good artificial light.
  - B. Never make a cutting height adjustment while the engine (motor) is running if the operator must dismount to do so.
  - C. Shut the engine (motor) off when removing the grass catcher or unclogging chute.
  - D. Check the blade mounting bolts for proper tightness at frequent intervals.
29. Under normal usage, the grass catcher bag material is subject to deterioration and wear. Check bag frequently for deterioration and wear and replace worn bags. Check that replacement bags comply with the original manufacturer's recommendations or specifications.
30. Disengage power to mower before backing up. Do not mow in reverse unless absolutely necessary and then only after careful observation of the entire area behind the mower.

62978/3560-72 Eng./10-22-86/RR-RD

## OWNER'S INFORMATION

Record the following information about your unit so that you will be able to provide it in case of loss or theft.

MODEL NUMBER: - (Enter complete 8 digit model number from model plate on unit)  
PURCHASE DATE: \_\_\_ / \_\_\_ / \_\_\_ CODE NO. \_\_\_\_\_ SERIAL NO. \_\_\_\_\_  
DEALER'S NAME AND ADDRESS \_\_\_\_\_  
CITY \_\_\_\_\_ STATE \_\_\_\_\_ TELEPHONE \_\_\_\_\_

### ⚠ WARNING ⚠

This unit is equipped with an internal combustion engine and should not be used on or near any unimproved forest-covered, brush-covered, grass-covered land unless the engine's exhaust system is equipped with a spark arrester meeting applicable local or state laws (if any). If a spark arrester is used, it should be maintained in effective working order by the operator. See your authorized Engine Service Dealer for proper spark arrester muffler for the engine on your unit.

### CONTENTS OF SHIPPING CARTON

- 1 - 36 inch Riding Mower
- 1 - Steering Wheel (with roll pin partially installed)
- 1 - Engine Manual (English)
- 1 - Engine Manual (French)
- 1 - Owner's Manual (English)
- 1 - Owner's Manual (French)
- 1 - Seat
- 1 - Bag of Assembly Parts Containing:
  - 1 - Trough (oil drain)
  - 2 - Battery Hold - Down Rods
  - 1 - Battery Hold-Down Bracket
  - 1 - Bag of Battery Hold-Down Parts Containing:
    - 2 - 1/4 inch Split Lockwashers
    - 2 - 1/4 inch Hex Nuts
    - 2 - 9/32 inch Flatwashers
  - 1 - Bag of Battery Cable Parts Containing:
    - 1 - 1/4 x 5/8 inch Carriage Bolt
    - 1 - 1/4 inch Keps Nut
    - 1 - 5/16 x 1/4 inch Carriage Bolt
    - 1 - 5/16 inch Keps Nut

- 1 - Bag of Seat Mounting Parts Containing:
  - 4 - 5/16 inch Split Lockwashers
  - 4 - 5/16 x 5/8 inch Hex Head Screws

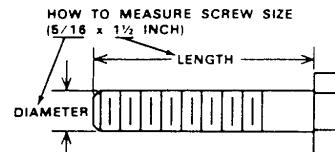

### TOOLS REQUIRED FOR ASSEMBLY

- 1 - 1/2 inch Wrench (or adjustable wrench)
- 1 - 7/16 inch Wrench (or adjustable wrench)
- 1 - Hammer (plastic or rawhide preferred)

### ⚠ DANGER ⚠

This riding mower can be dangerous if carelessly used.

Read Owner's Manual thoroughly before operating riding mower.

Always wear safety glasses or eye shields while assembling or operating riding mower.

DO NOT carry passengers at any time.

Keep hands, feet, hair and loose clothing away from discharge area, underside of mower deck or any moving parts while engine is running.

DO NOT allow children or young teenagers to operate or be near riding mower while it is operating.

## ASSEMBLY

Your riding mower is right or left hand as you face it from the rear.

### TO ACTIVATE BATTERY

1. Raise seat plate, lift battery and carton out of unit.  
**CAUTION:** Battery carton may not be sealed at bottom. Use care when lifting so that battery does not drop out of carton.

2. Fill battery with electrolyte battery acid available at most service stations or auto supply stores (follow instructions outlined on electrolyte package).

### ⚠ DANGER ⚠

Handle electrolyte with care. It is an acid and can be dangerous. Do not smoke while servicing battery.

3. For best battery life and service, battery should be trickle charged at two (2) to three (3) Amps overnight. **NOTE:** Battery can be boost charged at seven (7) Amps for thirty (30)

minutes if closely watched to make sure acid does not boil over.

4. If battery charger is not available, allow battery to set for 20 minutes before installing in unit. Battery should be strong enough to start engine. **NOTE:** Skip steps 5 through 12 and complete assembly section of this manual while waiting for battery to charge.

5. Raise seat and place battery back into unit with positive (+) terminal (figure 1) toward front of unit.

6. Place a battery hold-down rod through hole in each end of battery hold-down bracket.

7. Place a 9/32 inch flatwasher, a 1/4 inch lockwasher and a 1/4 inch hex nut onto each rod.

8. Position battery hold-down bracket onto top edge of battery (left or terminal side). **NOTE:** Be sure that the battery hold-down bracket is installed so that narrow side is on top of battery.

9. Place hook ends of battery hold-down rods into holes in main frame on each end of battery.

## CAUTION

Be sure that battery hold-down bracket does not touch battery terminals. When installing battery cables, install positive (red) cable first. When disconnecting battery cables, disconnect negative (black) cable first. Be sure that wrench does not touch any metal surface or both terminals, as damage to electrical system could result.

10. Tighten hex nuts to secure battery.
11. Attach positive (red) battery cable (figure 1) to positive (+) terminal on battery with a 5/16 x 3/4 inch carriage bolt and a 5/16 inch keps nut.
12. Attach negative (black) battery cable (figure 1) to negative (-) terminal on battery with a 1/4 x 5/8 inch carriage bolt and a 1/4 inch keps nut.

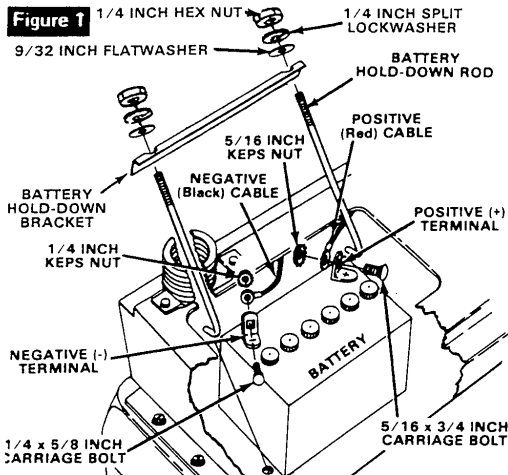

## SEAT INSTALLATION

1. Raise seat plate (figure 2) and attach seat to plate with four 5/16 x 1/2 inch screws and four 5/16 inch split lockwashers as shown.

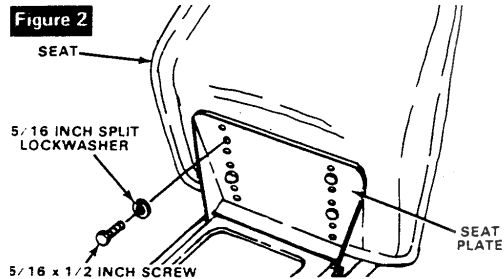

## STEERING WHEEL INSTALLATION

1. Position front wheels straight forward.
2. Push steering wheel (figure 3) onto steering shaft.
3. Align cross holes in steering wheel with holes in steering shaft.
4. Drive roll pin through holes with hammer.

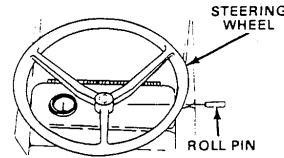

## TO SERVICE ENGINE

1. Place unit so engine is in a level position.
2. Pull out and rotate hood latches (figure 4) back away from hood pins. Pull out on bottom rear of hood and lift hood toward front. **NOTE:** Hood will be easier to lift if gas tank fill cap is removed.
3. Remove oil fill cap (figure 4). Using funnel, fill engine crankcase with oil. See **Engine Operation and Maintenance Manual** for proper procedure.
4. Reinstall oil fill cap and tighten securely.
5. Check to make sure that spark plug wire is tightened securely into engine and spark plug wire is attached to plug.
6. Return hood to closed position and reposition hood latches.
7. Fill gas tank (figure 4) with clean, fresh regular grade automotive gasoline. Low-lead gasoline is an acceptable substitute. Do not use Ethyl, high octane gasoline or Gasohol. Be certain container is clean and free from rust or other foreign particles. Never use gasoline that may be stale from long periods of storage in the container.

## ⚠ DANGER ⚠

Never fill the gas tank while the engine is running or is hot. Immediately wipe off any spilled gasoline before attempting to start engine.

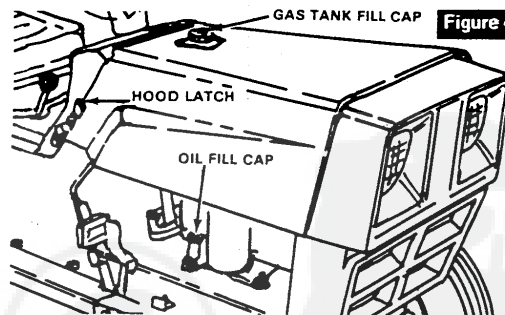

## TO SERVICE RIDER

1. If seat is not in a comfortable position, it can be moved. Raise seat and remove screws from underside of seat plate and reposition in most comfortable position.
2. Check tire pressure. Correct pressure (12 to 15 pounds) should be printed on sidewall of tires. Be sure that tires are inflated equally on both sides.
3. Check all nuts and bolts to be sure none are loose.
4. Return to Step 5 of To Activate Battery paragraph and complete battery installation.



## OPERATION

The operation of this riding mower can result in objects being thrown into the eyes, which can result in severe eye damage. Always wear safety glasses or eye shields while operating a riding mower. We recommend Wide Vision Safety Mask for over spectacles or standard safety glasses.

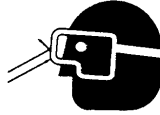

Get to know your riding mower and its controls. Be sure you (or any other operator) have read and understood the **Operational Precautions** listed on page 2 of this manual.

Your new mower will give years of service if cared for properly. Never run into trees, curbs, etc. Service regularly and store in dry area. Operate your mower at slow speeds until you become familiar with the machine. Avoid sharp turns at high speed and uphill or downhill turns. Operate mower carefully. Be especially cautious on hills. When riding down inclines, keep shift control in low speed with brake-clutch pedal out. This helps the engine control the speed. Use brake for fast stops on hills.

### ⚠ DANGER ⚠

**DO NOT operate this mower without the chute deflector in place. A riding mower can be dangerous to operate if misused. On slopes, be very cautious and avoid sharp turns to prevent tipping or loss of control. NEVER carry passengers.**

### CONTROLS

Figures 5 and 6 show all operating controls. The controls and their functions are as follows:

- **Throttle Control Lever** - Regulates engine and blade speeds and is used to choke engine. Engine should always be run at or near full speed for best grass cutting. **NOTE:** It may be necessary to push sideways on throttle lever to get it to go into START position.
- **Ignition/Headlight Switch** - Used to start and stop engine and turn headlights on and off. Turn key all the way right to 4th position to start engine. When key is released after starting engine it will return to 3rd (engine runs with headlights off) position. To turn headlights on, turn key left to 2nd (engine runs with headlights on) position. To stop engine, turn key left to 1st position. Remove key to lock ignition.
- **Ammeter** - Indicates whether battery is being recharged when engine is running. If charge (+) is not indicated while engine is running at full throttle and lights are off, have engine charging system checked by a competent engine repairman.

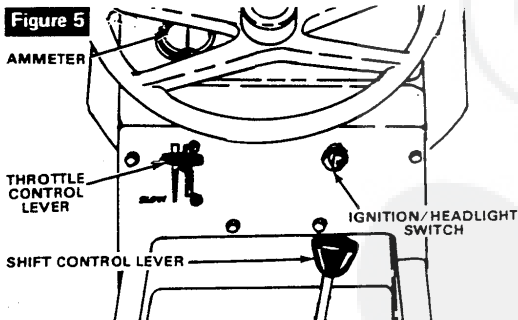

- **Shift Control Lever** - Used to select ground speed ranges as well as direction of motion (forward-neutral-reverse). Forward speed ranges are labeled 1-2-3.

No. 1 range is slowest forward speed (used for cutting tall or heavy grass), best gear for traveling up or down steep hills or when pulling heavy loads.

No. 2 range is for light mowing.

No. 3 should be used only when transporting mower.

## CAUTION

**Come to full stop before changing gears.**

- **Brake-Clutch Pedal** - This is a dual purpose control. Press pedal halfway down to disengage clutch. It is used for changing speed range or direction of travel (forward or reverse). Release pedal to engage clutch. With pedal completely depressed, brake is applied.

- **Parking Brake Lever** - Used to lock brake-clutch pedal in brake position.

1. Depress brake-clutch pedal fully, engaging brake.
2. Push parking brake lever forward and engage lever in notch of brake pedal.
3. To release parking brake, apply pressure to pedal and spring will release parking brake lever.
4. Check gear shift positions and know operating intentions before releasing brake.

- **Cutting Height Adjustment Lever** - Used to change height of cut.

1. Grasp lever (figure 6) with right hand and push outward to disengage lever from notch on quadrant.
2. Move lever to desired cutting height (toward rear of unit for high cut and forward for low cut).
3. After positioning lever at desired height of cut be sure lever engages notch on quadrant completely. The front notch on quadrant is lowest cutting height and rear notch is highest cutting height. Other notches change height of cut approximately 1/2 inch each.

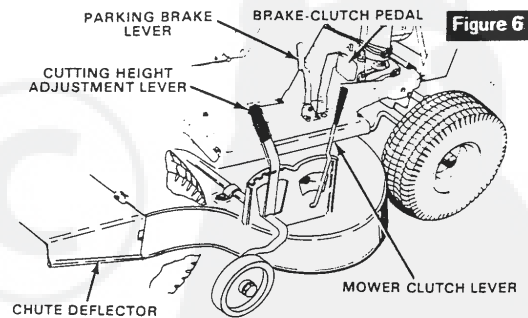

- **Mower Clutch Lever** - Used to connect or disconnect power to cutting blades. Become thoroughly familiar with operation of this control.

1. Move lever toward front of unit and latch into notch on quadrant to engage power to blades.
2. Move lever toward rear of unit to disengage power to blades and to apply blade brake.
3. The mower clutch control allows you to disconnect the

power source from the blades at any time while power to the drive wheels is still maintained and controllable. With mower clutch lever moved all the way to DISENGAGE (rearward) position, blades should stop in a safe period of time.

4. Always move mower clutch lever slowly to the ENGAGE (forward) position. Never "snap" the lever. It is also important to place lever to ENGAGE position while engine is running at FAST speed. This prevents excessive strain to belt.

**⚠ DANGER ⚠**  
Blades will not stop immediately. Keep hands and feet from under mower and away from the discharge chute.

5. Mower clutch lever must always be in full DISENGAGE position to start engine. Never place lever in ENGAGE position until engine is warmed up and operator is on unit ready to start mowing. Always return lever to DISENGAGE position before dismounting from unit.
6. Use DISENGAGE position when using unit as a tractor for yard jobs such as pulling a roller, seeder, sweeper or other accessories.

## TO START ENGINE

**IMPORTANT:** Your mower has two lockout switches that connect the solenoid to the brake-clutch pedal and mower clutch lever. When starting engine, the brake-clutch pedal must be fully depressed and mower clutch lever must be in full DISENGAGE position to engage the lockout switches. **ENGINE WILL NOT CRANK UNLESS THESE CONDITIONS ARE MET.** NOTE: Engine is supplied with **NO OIL**. Be sure that oil has been added. To start engine, proceed as follows:

1. Depress and hold brake-clutch pedal all the way down. Place shift lever in NEUTRAL position.
2. Place mower clutch lever to DISENGAGE position.
3. Place throttle control lever to START position.
4. Turn ignition key to START.
5. After engine starts, move throttle control lever to desired engine speed.
6. If engine fails to crank, check the following:
  - A. Be sure battery has been serviced and charged.
  - B. Be sure brake pedal is fully depressed and mower clutch lever is in DISENGAGE position.
  - C. Check fuse in red wire near back of ignition switch.
  - D. Be sure deck safety wire is connected to wire harness.
7. If engine cranks but fails to start, check the following:
  - A. Check to make sure fuel tank contains clean, fresh gasoline.
  - B. Carburetor adjustment may be necessary (see **Engine Operation and Maintenance Manual** for proper procedure).

**⚠ DANGER ⚠**  
Never run engine indoors or in enclosed, poorly ventilated areas. Engine exhaust contains **CARBON MONOXIDE**, an **ODORLESS** and **DEADLY GAS**.  
Keep hands, feet, hair and loose clothing away from any moving parts on engine or riding mower.  
**WARNING** - Temperature of muffler and nearby areas may exceed 150° F. Avoid these areas.

## RIDING ROTARY OPERATION

Take a comfortable riding position on the unit and start engine as outlined. After engine warmup, depress brake-clutch pedal halfway and move shift control lever to desired forward gear. **Release clutch pedal slowly and mower will move forward. Until you get the feel of the unit, stay in the low speed position.** With mower blades stopped, make your first run in a large, open, level area. Learn to stop, start and change directions in this area.

To put unit in reverse, depress brake-clutch pedal and move gear shift lever to reverse location. **Do not force the shift lever.** Always depress brake-clutch pedal and bring mower to a full stop.

To change speed range, depress brake-clutch pedal, come to a complete stop, and move shift lever to desired location. **Never force shift lever.**

Your engine speed is controlled by a throttle control lever and a built-in governor. A faster speed within a selected speed range can be obtained by speeding up the engine operating speed. For this reason, it is necessary that the proper speed range be selected for the cutting conditions encountered. See paragraph **Mower Hints** for further information.

To stop engine, turn ignition key to OFF position.

Once you learn to maneuver your unit, slowly move mower clutch lever to ENGAGE position to start mowing. To stop blades, move lever to DISENGAGE position.

**⚠ CAUTION**

1. KEEP ALL SHIELDS IN PLACE.
2. BEFORE LEAVING OPERATOR'S POSITION:
  - A. SHIFT TRANSMISSION TO NEUTRAL
  - B. SET PARKING BRAKE
  - C. DISENGAGE ATTACHMENT CLUTCH
  - D. SHUT OFF ENGINE
  - E. REMOVE IGNITION KEY
3. WAIT FOR ALL MOVEMENT TO STOP BEFORE SERVICING MACHINE.
4. KEEP PEOPLE AND PETS A SAFE DISTANCE AWAY FROM MACHINE.

## MOWING HINTS

One of the important things to learn about all rotary, and especially riding, mowers is that the forward speed of the machine must be controlled in accordance with the type and quantity of grass being cut. In other words, the more grass that must be cut, the slower the speed forward should be. When cutting light grass, the forward speed can be increased. By observing the cutting action of your mower, you can determine how fast you can travel. The engine should be run at or near full throttle and ground speed controlled by shift lever position. Your machine is very maneuverable and can be reversed to back out of dead ends.

Your mower may tend to leave unmowed strips when long and tender grass is being mowed. Tender grass has a high internal moisture content and is easily depressed by the mower wheels, and may not always spring back in time to be cut. To overcome this condition, we advise mowing the lawn in a counterclockwise direction, overlapping previous cut, which allows the lifting action of the rotating blades to lift the grass into the cutting path.

62978/3560-72 Eng./10-22-86/RR-RD

It is possible to spin the drive wheels of the unit under adverse conditions. The wheels are driven by a transaxle unit similar to an automobile differential. This makes short turns possible and prevents marring of the lawn. When one wheel slips, shift your weight over this wheel to obtain more pulling power.

**KEEP THE MOWER CLEAN.** Grass clippings may pack

under the mower chassis due to the internal moisture content of the grass. This accumulation of cut grass should be removed after each mowing. Disconnect spark plug wire, remove ignition key and scrape accumulation off with a putty knife or similar tool. Cleaning of the underside is easier if mower deck is removed. See paragraph **Mower Deck Removal.**

## ADJUSTMENTS

### ⚠ DANGER ⚠

Always disconnect spark plug wire before making any adjustments or repair.

### INTRODUCTION TO MECHANISM ADJUSTMENTS

Located beneath the main frame is a v-belt that transmits power to the transaxle which, in turn, transmits power to the rear wheels; a v-belt that transmits power to the two mower blades; and linkage that connects the brake-clutch pedal to the brake and the clutch.

Located on the mower deck is a clutch that disengages power to the blades and a deck leveling adjustment.

Before any adjustments are made, it is necessary that you understand the function of the brake, clutch, and the brake-clutch pedal. The pedal disengages the clutch when partially depressed and applies the brake when fully depressed.

Adjustment of the riding mower drive belt and brake must be synchronized so brake does not grab before clutch disengages. An incorrect adjustment causes brake to grab or hold while power is being transmitted to the rear wheels. Riding mower will try to move with brake applied, this will cause difficulty when shifting from one speed range or direction to another.

To replace drive belts, you must remove mower deck. Removal of deck isn't necessary for other adjustments, but if several adjustments are needed, it will be more convenient if deck is removed.

### CAUTION

At no time during the adjustments or repairs can the unit be lifted more than 20 inches from level position without taking the following precautions:

1. Remove gasoline from tank and run engine until carburetor is dry.
2. Remove battery (see **BATTERY REMOVAL** paragraph in **MAINTENANCE** section of this manual).
3. Remove oil from crankcase.

### MOWER DECK REMOVAL

1. Disconnect spark plug wire and turn unit wheels maximum left. Block up front of mower deck.
2. Set mower clutch lever to the disengaged position to relieve tension on the mower blade drive belt.
3. Disconnect the deck safety wire (figure 9) from wire harness (figure 7) under main frame. **NOTE:** The by-pass wire (figure 7) must be connected to the wire harness on the main frame in order to start the engine while deck is removed.
4. Remove hairpin cotter from pull pin on the front of the mower deck and remove pull pin (figure 8).

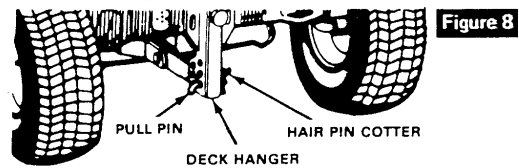
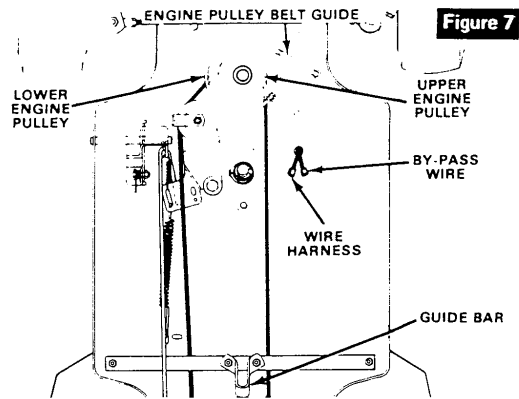

5. Move mower deck forward to free rear deck guide (figure 9) from rear deck guide bar (figure 7), then loosen belt guides (figure 7) on engine pulley and remove mower deck drive belt from engine pulley.

6. Deck can now be worked out from under the right side of unit. **NOTE:** Deck removal will be easier if front of unit is raised enough to allow deck hitch to slide out under right front wheel.

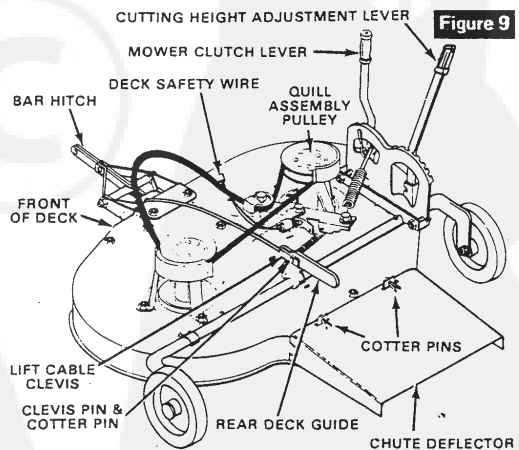

7. Chute deflector is removed by removing two cotter pins from top rear of deck (see figure 9).

8. Installation of deck is reverse of removal.

9. Reconnect deck wire to unit wire harness and reconnect spark plug wire.

### MOWER DECK LEVELING ADJUSTMENT

The cutting height (from blade tip to ground) should be from 0 inch to 1/8 inch less at front of deck than at rear of deck. To adjust:

1. Disconnect spark plug wire.
2. Measure height of blade from level floor at front and rear deck (make sure tires are properly inflated). If distances are equal or not more than 1/8 inch less in the front, no adjustment is necessary.
3. If adjustment is necessary, place cutting height adjustment lever in extreme low cut position (full forward).
4. Place a block under front of mower deck (figure 9) to remove weight from the unit. Lift cable will be slack.
5. Remove cotter pin from clevis pin. Remove clevis pin.
6. Turn rear clevis clockwise to raise front of deck. Turn counterclockwise to lower front of deck. Each 1 1/2 complete turns of clevis represents approximately 1/8 inch change in the front of mower deck.
7. Reinstall clevis and clevis pin. Remove block. Check front and rear measurements. If measurements are correct, reinstall cotter pin. If more adjustment is necessary, repeat preceding instructions.
8. Reconnect spark plug wire.

### **⚠ DANGER ⚠**

Keep hands, feet, hair and loose clothing away from any moving parts on engine or riding mower when making any adjustments that require engine to be running. DO NOT carry passengers.

### BLADE DRIVE BELT ADJUSTMENT

When mower blades will not rev to full speed or slip while mowing, the blade drive belt should be tightened. To adjust:

1. Disconnect spark plug wire and place mower clutch lever in disengage position.
2. Remove screw from lock bracket (figure 10).
3. Loosen locknut on bar hitch screw securing bar hitch to pivot bracket (figure 10).
4. Slide mower deck rearward to tighten belt. **NOTE:** Only a small amount of movement should be required.
5. Retighten locknut on bar hitch screw.

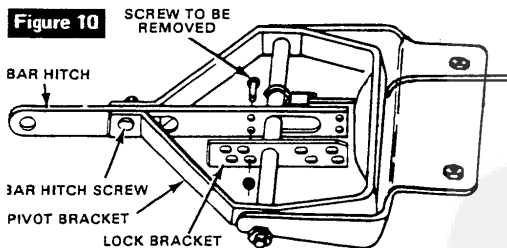

6. To check adjustment, reconnect spark plug wire, start engine and run engine at FAST engine control setting. Engage mower clutch lever and allow sufficient time for

blades to run to full speed, then disengage mower clutch lever. Blade should stop within a few seconds and remain stopped. If blades do not stop or tend to creep, adjustment is too tight.

### **⚠ DANGER ⚠**

Blades will not stop immediately. Keep hands and feet from under mower and away from the discharge chute.

7. To loosen blade drive belt, reverse step 4 above.
8. Reinstall and tighten screw in lock bracket through any hole that aligns with one of four holes in bar hitch.

### BLADE BRAKE ADJUSTMENT

The brake pad (attached to idler arm) should completely clear the right quill assembly (figure 11) when mower clutch lever is in engaged position. To adjust:

1. Disconnect spark plug wire.
2. Move mower clutch lever to disengaged position.
3. Push mower clutch lever forward until slack is removed from blade clutch lever spring (figure 11).
4. Check clearance between clutch lever and rear stop on quadrant. Clearance should be between 1/2 and 3/4 inch.
5. If clearance is less than 1/2 inch, loosen shoulder bolt securing mower clutch lever spring (figure 11) to idler arm. Slide shoulder bolt in slot on idler arm as far as possible away from clutch lever without reducing lever clearance to less than 1/2 inch.
6. Retighten shoulder bolt and reconnect spark plug wire.

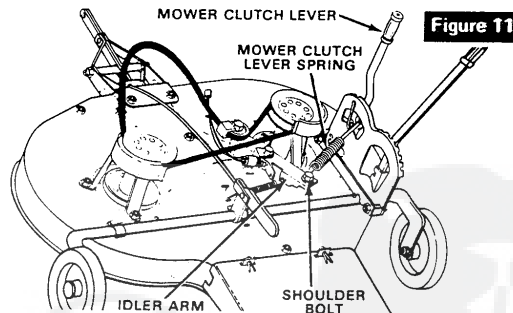

### UNIT BRAKE ADJUSTMENT

This riding mower is equipped with an adjustable disc brake mounted on the transaxle. Place shift control lever to neutral position and depress brake-clutch pedal enough to latch parking brake lever in second notch. Brake should be disengaged and you should be able to push riding mower. If you are unable to push riding mower, brake is too tight and you need to loosen brake. With shift control lever in neutral position and parking brake lever in fourth notch, brake should be applied. If you are able to push riding mower, brake is too loose and you need to tighten brake. Brake must be set when parking brake lever is in the fourth position. To adjust brake, proceed as follows:

1. Disconnect spark plug wire.
2. Place shift control lever to neutral position and depress brake-clutch pedal enough to latch parking brake lever in second notch.



3. Turn brake adjustment nut (figure 12) clockwise to tighten (counterclockwise to loosen) until brake pad just clears brake disc.
4. Check unit brake adjustment as described above.
5. Reconnect spark plug wire.

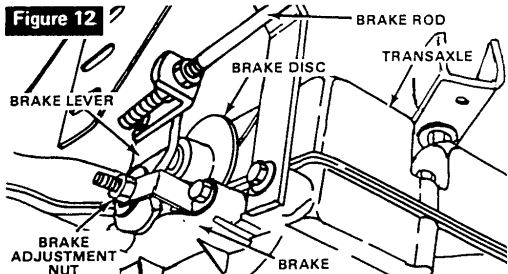

### UNIT DRIVE BELT ADJUSTMENT

The drive belt is kept tight by a spring attached to the idler arm assembly. When drive belt is properly adjusted, the brake-clutch pedal, in fully released position, should appear as shown in figure 13 insert (foot pad straight up and down).

To adjust drive belt, proceed as follows:

1. Disconnect spark plug wire.
2. Depress brake-clutch pedal far enough to latch parking brake in first 1st notch. **NOTE:** Parking brake has four (4) notches with number one (1) notch at top nearest pedal pad.
3. Drive belt should not be loose. If belt is loose, proceed as follows:
  - A. Loosen drive idler pulley (figure 13) mounting screw.
  - B. Push idler pulley toward outside of main frame (away from engine pulley) until belt is tight.

Figure 13

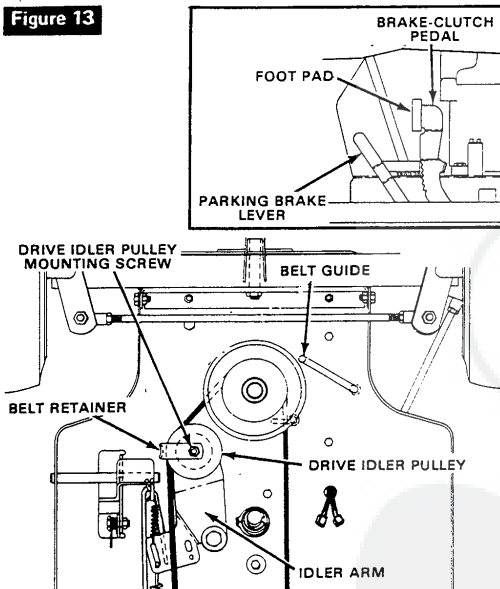

- C. Retighten idler pulley mounting screw. **NOTE:** Be sure belt retainer is positioned as shown in figure 13 (straight toward side of main frame when brake-clutch pedal is released).

4. Check unit brake adjustment as outlined in Unit Brake Adjustment paragraph.
5. Reconnect spark plug wire.

### STEERING GEAR ADJUSTMENT

The steering gear was properly adjusted at the factory. If excessive play develops in the steering, adjust pinion and sector gears (figure 14 inset) as follows:

1. Disconnect spark plug wire.
2. Turn sector gear adjusting bolt (inset, figure 14) to move sector gear forward or backward as needed (slightly loosen sector gear mounting screw under main frame if necessary). **NOTE:** When hole in sector gear adjusting bolt top is in forward position (toward engine), sector gear is adjusted as tight as possible. When hole is in rearward position (away from engine), sector gear is adjusted as loose as possible.
3. Reconnect spark plug wire.

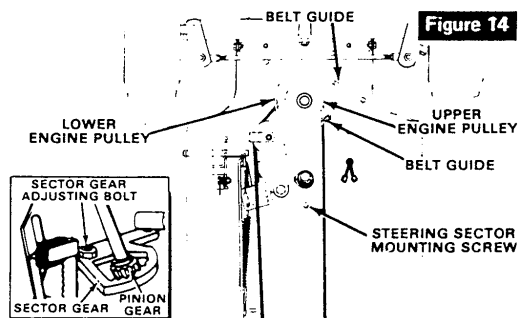

### BELT GUIDES

This unit is equipped with belt guides (figure 14) located next to the engine pulley. These belt guides are angle rods secured to the main frame. The guides are moved (by loosening locknuts) before replacing belts. When repositioning (after new belt installation) allow 1/16 inch gap between guide and belt.

### CARBURETOR ADJUSTMENT

Never make unnecessary adjustments. The factory settings are correct for most applications. If necessary, however, refer to Engine Operation and Maintenance Manual.

### SPARK PLUG ADJUSTMENT

Spark plug should be checked periodically for excessive carbon and gap. The spark plug gap should be checked with a wire feeler gauge and set at .030 inch.

## MAINTENANCE

### UNIT DRIVE BELT REPLACEMENT

Your riding mower uses two v-belts made of special compounds. If either belt becomes worn or breaks, replace with **original equipment belt** (see **Repair Parts** section). **NEVER USE A SUBSTITUTE.** To replace unit drive belt:

1. Disconnect spark plug wire.
2. Remove mower deck. See **Mower Deck Removal** paragraph in **Adjustment** section of this manual.
3. Depress brake-clutch pedal and set parking brake.
4. Loosen clutching idler pulley belt retainer (figure 15) and remove belt from pulley
5. Loosen upper pulley belt guide (figure 15) and pull away from pulley.
6. Remove cotter pin and washer that attach shift lever to transaxle (figure 15 insert) and remove shift lever from transaxle shift bracket.
7. Remove belt from transaxle pulley (roll belt off over top of pulley).
8. Remove belt from engine pulley and replace with new original equipment belt in reverse order of removal.
9. Reinstall shift lever to transaxle shift bracket with removed washer and cotter pin.
10. Release parking brake and position belt retainer on drive idler pulley as shown in figure 15.
11. Adjust belt guides. See **Belt Guides** paragraph in **Adjustment** section of this manual.

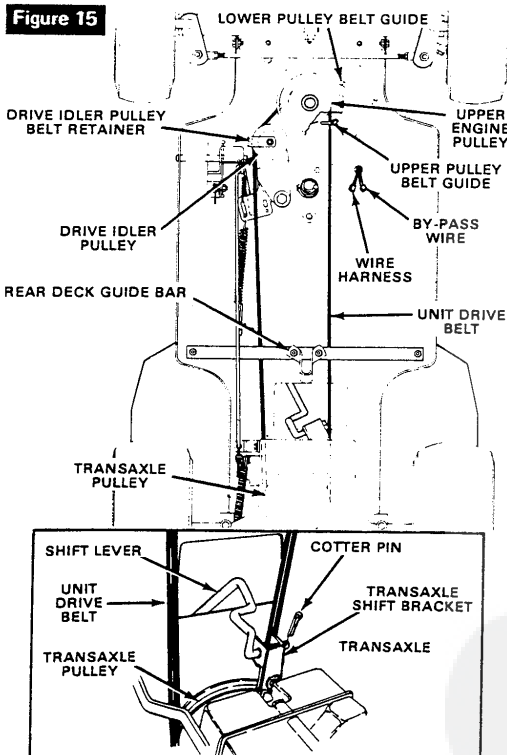

12. Make drive belt adjustment. See **Unit Drive Belt Adjustment** paragraph in **Adjustment** section of this manual.

13. Check unit brake adjustment. Make adjustment if necessary. See **Unit Brake Adjustment** paragraph in **Adjustment** section of this manual.

14. If blade drive belt is to be replaced, do so before reinstalling mower deck assembly.

15. Reinstall mower deck, reconnect deck safety wire and spark plug wire.

### BLADE DRIVE BELT REPLACEMENT

1. Disconnect spark plug wire and remove mower deck. See **Mower Deck Removal** paragraph in **Adjustment** section of this manual.
2. Place height adjustment lever in extreme low cut position.
3. Note position of belt guide (crosswise of unit with mower clutch lever in engage position) on idler pulley (figure 16) so that guide can be reinstalled to proper position. Remove idler pulley.
4. Loosen both mower deck belt guards (figure 16) enough to allow belt to be removed from pulleys and remove old belt.
5. Replace belt, tighten belt guards and reinstall idler pulley. Place mower clutch lever in engage position and adjust idler pulley belt guide to crosswise of unit.
6. Reinstall mower deck and adjust belt as described in paragraph **Blade Drive Belt Adjustment** in **Adjustment** section.
7. Reconnect spark plug wire.

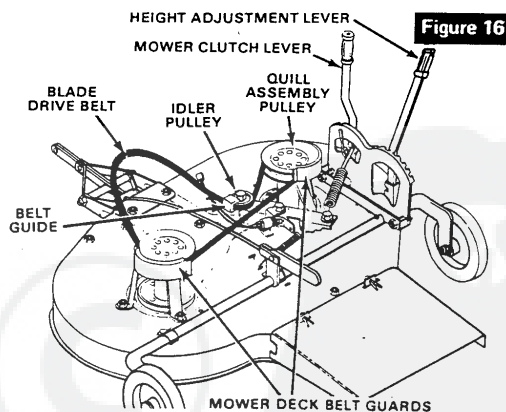

### BLADE REPLACEMENT

The cutting blades should be sharp and well-balanced to run smoothly. Blades should have correct amount of "lift" for proper cutting and discharge of clippings. Lift is created by upturned bent tip edges (figure 17) of blade ends. As cutting edges of blades wear, the bent tip edges also wear, decreasing blade lift, resulting in decreased cutting ability. Because of this, resharpening of blades will not help much. It is recommended that blades be replaced.

**IMPORTANT:** Stop engine, disconnect spark plug wire and inspect blades at once if you strike any solid unyielding object. Check to make sure blade mounting screws are tight. To remove blades:

62978/3560-72 Eng./10-22-86/RR-RD

1. Remove mower deck (see paragraph **Mower Deck Removal in Adjustment** section).

2. With a 9/16 inch wrench, remove blade mounting screws (figure 17) by turning screws counter-clockwise.

When replacing blades, be sure all parts are reassembled in proper order (see **Repair Parts** section for proper order) or severe vibration will occur. Bent tip edges of blades must be up toward top of mower deck or blades will not cut. **NOTE: Make sure blade mounting screws are tightened securely.** We recommend a 10 inch wrench or a torque wrench. If torque wrench is used, torque blade mounting screws to between 30 and 35 foot pounds.

3. Reinstall mower deck and reconnect spark plug wire.

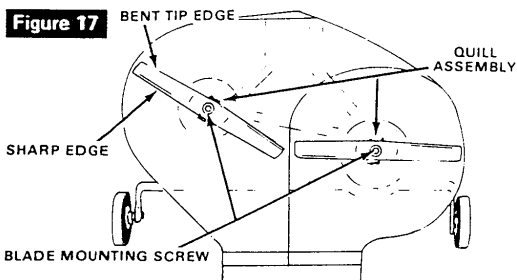

### AIR FILTER MAINTENANCE

The air filter should be cleaned and re-oiled every 25 hours of operation under normal operating condition; more often under dusty conditions. To clean air filter, proceed as instructed in **Engine Operation and Maintenance Manual**.

### CAUTION

Never run the engine without the air cleaner element installed. A defective air cleaner can result in loss of engine power and can create excessive wear or damage to engine components if dirt or dust is permitted to enter engine through the carburator. A damaged air cleaner, or one that is clogged with dust or dirt should be replaced immediately.

### TO CHANGE CRANKCASE OIL

Crankcase oil should be changed after first 5 hours of operation and every 25 hours thereafter. See **Engine Operation and Maintenance Manual** for proper procedure. Check oil level before each use. Add oil as required.

1. Disconnect spark plug wire.

2. Place oil drain trough under oil drain plug (figure 18). Place a flat bottom 2 quart container beneath trough. **NOTE:** It may be necessary to raise left side of unit (with blocks under left wheels) to get proper drainage.

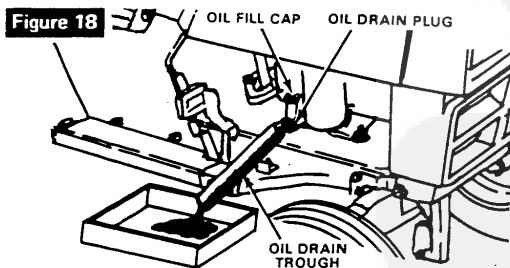

3. Remove plug to drain oil. **NOTE:** Oil fill cap should be loosened to serve as an air vent.

4. Reinstall plug, remove oil fill cap and refill crankcase as outlined in **Engine Operation and Maintenance Manual**.

5. Reinstall oil fill cap and reconnect spark plug wire.

### BATTERY REMOVAL

1. Raise seat and disconnect negative (black) battery cable (figure 19). **NOTE:** Be sure wrench does not touch any metal surface or other battery terminal.

2. Disconnect positive (red) battery cable.

3. Loosen wing nuts (figure 19) enough to unhook battery hold-down rods.

### CAUTION

Be sure that battery hold-down bracket does not touch battery terminals. When installing battery cables, install positive (red) cable first. When disconnecting battery cables, disconnect negative (black) cable first. Be sure that wrench does not touch any metal surface or both terminals, as damage to electrical system could result.

4. Lift battery out of unit.

5. Installation of battery is reverse of removal. **NOTE:** Be sure to reconnect positive (red) cable first and do not allow wrench to touch any metal surface or other terminal.

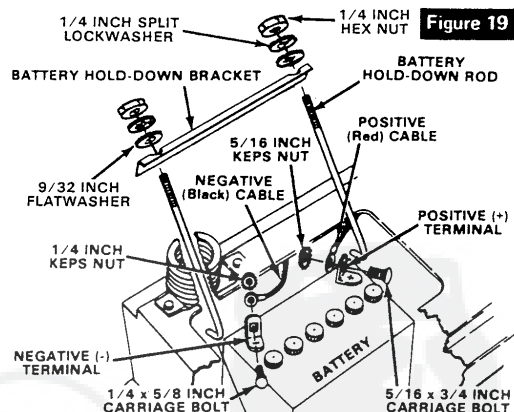

### BATTERY MAINTENANCE

1. If mower is used often, check level of electrolyte once a month. If low, add clean water until fluid reaches split ring indicator. **NEVER ADD ELECTROLYTE!**

If battery needs more than 2 or 3 ounces of water in each cell per month, the charging system may be malfunctioning. The alternator may be over-charging and this should be corrected by a trained serviceman.

2. When starter operates properly and battery connections are clean and tight but cranking difficulty is experienced, battery may not be charged. Battery should be taken to a qualified service station and tested.

3. If engine will not start right away under normal cranking speed, continued cranking will run down the battery and may cause damage to starter. Check ignition and fuel systems and correct any faults.

4. The battery should be kept clean. If the top has an

accumulation of dirt or grease, remove the battery from the vehicle for cleaning. The battery should be cleaned with a mild solution of baking soda and water. **Brush this on, keeping vent plugs tightly in place to prevent any solution from entering the cells.** Allow the solution to work for a few minutes, then rinse with clean water and wipe battery dry. If battery terminals are corroded, clean with a wire brush and coat terminals with petroleum jelly. **Be sure to reinstall battery in the same position and properly reconnect battery cables (red to positive, black to negative).**

Proper care will lengthen battery life. When replacement becomes necessary, use battery of same size and type for continued trouble-free service (see **Repair Parts** section of this manual).

## LUBRICATION

Lubricate as shown in **Lubrication Chart**. The transaxle has been lubricated for life.

## WIRING DIAGRAM

Parts breakdown on page 22 of this manual is designed to be used as a wiring diagram.

We recommend that unless you are fully qualified to make repairs on the electrical system on this unit, you take it to a competent repairman for such work or adjustments.

## STORAGE

The riding mower should be immediately prepared for storage at the end of the season or if the unit is to be un-used for 30 days or more.

### **⚠ DANGER ⚠**

Never store engine with fuel in tank indoors or in enclosed, poorly ventilated enclosures, where fuel fumes may reach an open flame, spark or pilot light as on a furnace, water heater, clothes dryer, etc.

Handle gasoline carefully. It is highly flammable and careless use could result in serious fire damage to your person and/or property.

Drain fuel into an approved container outdoors, away from open flame.

## BATTERY STORAGE

1. Remove battery (see **Battery Removal** paragraph in **Maintenance** section of this manual).
2. Before storage, add clean water to split ring indicator and fully charge battery. A discharged battery will freeze and may burst. If possible, place battery in a cool dry area. Charge battery overnight every 30 days.
3. Clean battery as instructed in **Battery Maintenance** paragraph in **Maintenance** section of this manual.

## ENGINE STORAGE

Gasoline, if permitted to stand un-used for extended periods (30 days or more), may develop gummy deposits which can adversely affect the engine carburetor and cause engine malfunction. To avoid this condition, proceed as follows:

1. Prior to shut down for 30 days or more, drain fuel tank.
2. Run engine until fuel tank is empty and engine stops due to lack of fuel.
3. Remove spark plug and pour one (1) ounce of engine oil through spark plug hole into cylinder. Crank engine several times to distribute oil. Reinstall spark plug.

## UNIT STORAGE

1. Clean the unit thoroughly.
2. Inspect the riding mower for worn or damaged parts and tighten all loose screws and nuts.
3. Lubricate all points shown in **Lubrication Chart**.
4. Store the riding mower in a protected area and cover the unit for additional protection.

A yearly check-up or tune-up by a qualified repairman is a good way of insuring that your riding mower will provide maximum performance for the next season.

62978/3560-72 Eng./10-22-86/RR-RD



## LUBRICATION CHART

Orientation view only. Do Not stand on end.

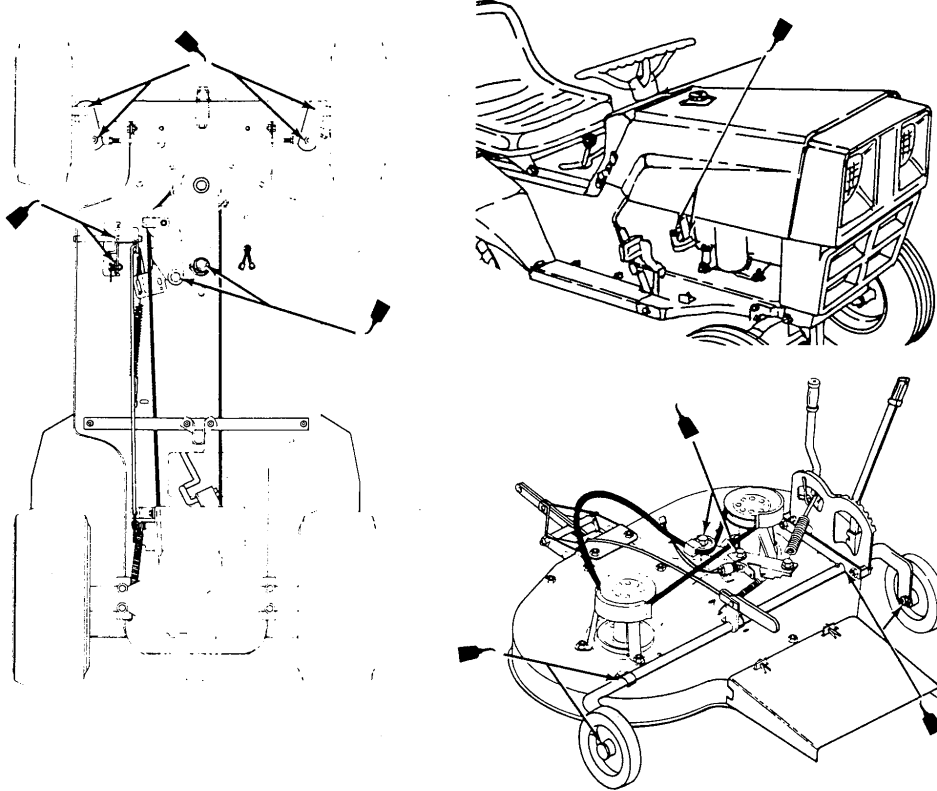

USE SAME OIL USED IN CRANKCASE EVERY 25 HOURS OF OPERATION.

## PREVENTIVE MAINTENANCE CHART

**DANGER: ALWAYS DISCONNECT SPARK PLUG WIRE BEFORE ATTEMPTING ANY REMEDY!**

FREQUENCY	PART	CARE
Before each use:	Engine Crankcase	Check oil level. Add as needed.
Every 25 hours of use or sooner as needed.	Engine Crankcase	Change oil.
	Engine Air Filter	Clean and Re-oil.
	Steering Wheel Shaft	Oil each end.
	Steering Sector	Oil.
	Front Spindles	Oil.
	Front Wheel Bearings	Oil.
	Battery	Check fluid level.
Every 50 hours of use or sooner as needed:	All the points listed under the 25 hour check plus those below:	
	Linkage & Pivot Points	Oil all locations.
	Tires	Check pressure, 12 to 15 pounds.
Before storage:	Engine	Drain gasoline tank & carburetor. Oil cylinder.
Beginning of season:	All points listed under 25 hour and 50 hour checks.	

The following **Trouble Shooting Guide** (2 pages) is designed to apply to all riding type mowers manufactured by Western International Incorporated. Some of the problems and corrections will not apply to your unit.

<b>TROUBLE SHOOTING GUIDE</b>	
<i>DANGER: ALWAYS DISCONNECT SPARK PLUG WIRE BEFORE ATTEMPTING ANY INSPECTION OR ADJUSTMENT.</i>	
PROBLEM	CORRECTION
Mower Cuts Ragged or Uneven	<ol style="list-style-type: none"> <li>1. Remove any accumulation of grass clippings from underside of mower deck housing.</li> <li>2. Make certain blades are sharp and in good condition (not bent or incorrectly mounted).</li> <li>3. Check blade mounting screw(s). Blade screw(s) must be tight.</li> <li>4. Check mower deck leveling adjustment per manual. Adjust if necessary.</li> <li>5. Check blade belt tension per manual. Adjust if necessary.</li> <li>6. Check quill assembly(s) for damage or wear. Replace if necessary.</li> <li>7. Check for possible damage to mower deck housing. Repair or replace if necessary.</li> <li>8. Check pivot tube assembly for damage. If bent or damaged, repair or replace.</li> </ol>
Mower Leaves Unmowed Strip Between Blades	<ol style="list-style-type: none"> <li>1. Mowing a heavy strand of grass or grass with excessive surface moisture could allow mower to leave an unmowed strip. Mow counterclockwise (side discharge only). <b>Do not</b> mow wet grass.</li> <li>2. Forward speed should be adjusted to mowing conditions by gear selection. Engine should be run at full throttle.</li> <li>3. Make certain blades are sharp and in good condition. Replace if necessary.</li> <li>4. Check blade belt tension. Adjust if necessary.</li> <li>5. Check quill assembly(s) for damage or wear. Replace if necessary.</li> <li>6. Check for damage to mower deck housing. Repair or replace if necessary.</li> </ol>
Mower Scalps Lawn	<ol style="list-style-type: none"> <li>1. Check mower height adjustment setting and readjust if needed. Scalping is more likely on rough or uneven lawns.</li> <li>2. Check for damage to mower deck housing. Repair or replace if necessary.</li> <li>3. Check for bent blade(s) or quill assembly(s). Replace if necessary.</li> <li>4. Check mower deck leveling adjustment and adjust if necessary.</li> </ol>
Mower Will Not Discharge Clippings	<ol style="list-style-type: none"> <li>1. Remove any accumulation of grass clippings from underside of mower deck housing.</li> <li>2. Wet conditions can cause the discharge chute and underside of mower deck to become plugged with clippings. <b>Do not</b> mow wet grass.</li> <li>3. Forward speed should be adjusted to mowing conditions by gear selection. Engine should be run at full throttle.</li> <li>4. When mowing long grass make first cutting in high position, then recut at normal cutting height.</li> <li>5. Check blade belt tension per manual. Adjust if necessary.</li> <li>6. If blade(s) have been replaced, make sure they have been correctly mounted.</li> </ol>
Blade Drive Belt Comes Off During Use	<ol style="list-style-type: none"> <li>1. Blade drive belt may suffer internal damage to cords when it comes off during use. If belt still comes off after checking all steps below, replace belt with a new original equipment belt.</li> <li>2. Check belt tension per manual. Adjust if necessary.</li> <li>3. Check belt guide. Correct clearance is 1/16 inch from belt when blade engage lever is engaged.</li> <li>4. Check mower deck leveling adjustment per manual. Adjust if necessary.</li> <li>5. Check for and remove any foreign objects interfering with belt travel.</li> <li>6. Check all pulleys on mower deck. A bent or split pulley could cause problems. Replace if necessary.</li> <li>7. Check engine drive pulley inner surface. If inner surface is rough or split, pulley should be replaced.</li> <li>8. Check blade throw-out assembly for wear. Replace necessary parts.</li> </ol>
Blade Drive Belt Slips	<ol style="list-style-type: none"> <li>1. If grass is too high or wet, belt slippage may occur.</li> <li>2. Check belt for wear or damage. Replace if necessary.</li> <li>3. Check blade belt tension per manual. Adjust if necessary.</li> <li>4. Check blade drive belt tension spring. If spring is stretched or damaged, replace spring.</li> </ol>
Blade Drive Belt Wears Excessively	<ol style="list-style-type: none"> <li>1. Check all belt guides. Correct clearance is 1/16 inch from belt when blade engage lever is engaged.</li> <li>2. Check for and remove any foreign objects interfering with belt travel.</li> <li>3. Check pulleys for damage. Replace if necessary.</li> <li>4. Make certain belt brake is clearing belt when mower is engaged. If brake cable is too long or broken, adjust or replace.</li> <li>5. Make certain mower deck leveling adjustment is correct. Adjust if necessary.</li> <li>6. Check blade belt tension per manual. Adjust if necessary.</li> </ol>
Blade(s) Will Not Engage	<ol style="list-style-type: none"> <li>1. Check belt. If worn or broken, replace. If belt is too loose, make belt adjustment.</li> <li>2. Check engagement spring on deck engagement idler. If broken or damaged, replace.</li> <li>3. Check for and remove any foreign objects interfering with engagement idler travel.</li> </ol>
Blade(s) Will Not Disengage	<ol style="list-style-type: none"> <li>1. Check blade belt tension per manual. Adjust if necessary.</li> <li>2. If blade drive belt adjustment will not provide enough slack in drive belt, replace with correct <b>Original Equipment Belt</b>.</li> <li>3. Check for and remove any foreign objects interfering with engagement idler travel.</li> </ol>

62978/3560-72 Eng./10-22-86/RR-RD

## TROUBLE SHOOTING GUIDE (Continued)

**DANGER: ALWAYS DISCONNECT SPARK PLUG WIRE BEFORE ATTEMPTING ANY INSPECTION OR ADJUSTMENT.**

PROBLEM	CORRECTION
Extreme Vibration Occurs When Blade is Engaged	<ol style="list-style-type: none"> <li>1. Check blade(s) and make certain they are not bent, out of balance or loose. Replace if necessary.</li> <li>2. Check belt for burn spots or irregularities that might cause vibration. Replace if necessary.</li> <li>3. Check quill assembly(s) for damage or wear. Replace if necessary.</li> <li>4. Check for worn or damaged blade engagement parts. Repair or replace as necessary.</li> <li>5. Check engine drive pulley inner surface. If inner surface is rough or split, pulley should be replaced.</li> <li>6. Check under side of mower deck housing for accumulation of clippings. Remove accumulated clippings.</li> <li>7. Check for loose or damaged engine mounts. Tighten or replace as necessary.</li> <li>8. Check blade belt tension per manual. Adjust if necessary.</li> </ol>
Deck or Deck Wheel and Tire Assembly	<ol style="list-style-type: none"> <li>1. Deck drive belt adjustment is too tight. Readjust.</li> <li>2. Other than <b>Original Equipment Belt</b> is being used and is either too long or stretched. Replace belt.</li> <li>3. Belt is worn. Replace with new <b>Original Equipment Belt</b>.</li> <li>4. Check pivot tube assembly for damage. Repair or replace if necessary.</li> </ol>
Deck Lift Cable Broken	<ol style="list-style-type: none"> <li>1. Check operating procedure. Excessive ground speed on rough lawn may cause mower deck bounce, resulting in lift cable failure.</li> <li>2. Remove excessive clippings from underside of mower deck housing (build-up of clippings adds excessive weight to mower deck).</li> </ol>
Unit Drive Belt Slips	<ol style="list-style-type: none"> <li>1. Check unit drive belt adjustment(s). Adjust if necessary.</li> <li>2. Check for damaged or broken clutching idler spring. Replace if necessary.</li> <li>3. Check belt(s) for wear or damage. Replace if necessary.</li> <li>4. Check for and remove any foreign objects obstructing clutching idler mechanism.</li> <li>5. Check for split engine or transmission pulley. Replace if necessary.</li> <li>6. Check for damaged engine mounts (shock mounted engine only). Replace if necessary.</li> </ol>
Unit Drive Belt Squeals When Brake is Applied	<ol style="list-style-type: none"> <li>1. Check riding mower drive belt adjustment and riding mower brake adjustment per manual. Adjust if necessary.</li> <li>2. Check for and remove any foreign objects obstructing vari-speed or clutching idler mechanism.</li> </ol>
Unit Drive Belt Comes Off During Use	<ol style="list-style-type: none"> <li>1. Check belt tension. Adjust if necessary.</li> <li>2. Check belt guides. Adjust if necessary.</li> <li>3. Check for split or damaged pulley(s). Replace if necessary.</li> <li>4. Check clutching idler pulley alignment. If out of alignment, idler bracket may be bent. Replace if necessary.</li> </ol>
Unit Will Not Propel Itself When Clutch is Engaged	<ol style="list-style-type: none"> <li>1. See <b>Steps 1 through 6</b> in <b>Unit Drive Belt Slips</b> section of this chart.</li> <li>2. Check engine, transmission or transaxle pulley(s) for sheared or missing key. Replace if necessary.</li> <li>3. Check transmission or transaxle to make certain it is operable. Make certain chain (chain drive units only) is intact.</li> </ol>
Extreme Vibration Occurs When Clutch is Engaged (Let-Out)	<ol style="list-style-type: none"> <li>1. Check for split or damaged pulley(s). Replace if necessary.</li> <li>2. Check belt for irregularities or burned spots. Replace if necessary.</li> <li>3. Make certain belt tension is correct. Adjust if necessary.</li> <li>4. Check clutching idler assembly for wear or damage. Replace parts as necessary.</li> <li>5. On chain drive units, check sprockets for proper alignment and chain damage. Replace if necessary.</li> <li>6. Check for loose or damaged engine mounts. Tighten or replace as necessary.</li> </ol>
Unit Will Not Shift or Shifts Hard	<ol style="list-style-type: none"> <li>1. Check shifting procedure. Unit <b>MUST</b> come to a complete stop before shifting.</li> <li>2. Check riding mower drive belt adjustment and riding mower brake adjustment per manual. Adjust if necessary.</li> <li>3. Have transmission or transaxle checked by a competent repairman</li> </ol>
Steering Slips or is Loose	<ol style="list-style-type: none"> <li>1. Check for steering sector gear and pinion looseness. If gears are loose, make sector gear adjustment.</li> <li>2. Check ball joints for wear. Replace if necessary.</li> </ol>
Engine Will Not Turn Over	<ol style="list-style-type: none"> <li>1. Check starting procedure. Make sure starting instructions are followed.</li> <li>2. Check fuse (if so equipped).</li> <li>3. Check battery for charge. Make sure battery has been activated and charged (on new units).</li> <li>4. On new units, remove spark plug and check cylinder for accumulation of oil due to improper handling.</li> <li>5. Make visual check of electrical system to make sure all connections and lockout switches are secure.</li> <li>6. Check engine according to engine manufacturers instructions.</li> <li>7. Have electrical system checked by a competent repairman.</li> </ol>
Engine Turns Over But will Not Start	<ol style="list-style-type: none"> <li>1. Check starting procedure. Make sure starting instructions are followed.</li> <li>2. Make certain fuel tank is filled with clean, fresh gasoline.</li> <li>3. Make certain fuel shut-off is open (if so equipped).</li> <li>4. Make certain that throttle is in start or fast position.</li> <li>5. Check engine according to engine manufacturers instructions.</li> <li>6. On recoil start unit, make visual check of wiring system to make sure all connections and lockout switches are secure.</li> <li>7. Have wiring and lockout switches (on recoil start unit) checked by a competent repairman.</li> <li>8. Check fuel filter for obstructions.</li> </ol>

# REPAIR PARTS

## 36" RIDING MOWER MODEL 3560-91

**NOTE: ALWAYS USE ORIGINAL EQUIPMENT PARTS** Use of service/replacement parts other than original equipment parts may void your warranty

ALL UNNUMBERED ITEMS ARE INTERCHANGEABLE WITH OPPOSITE SIDE

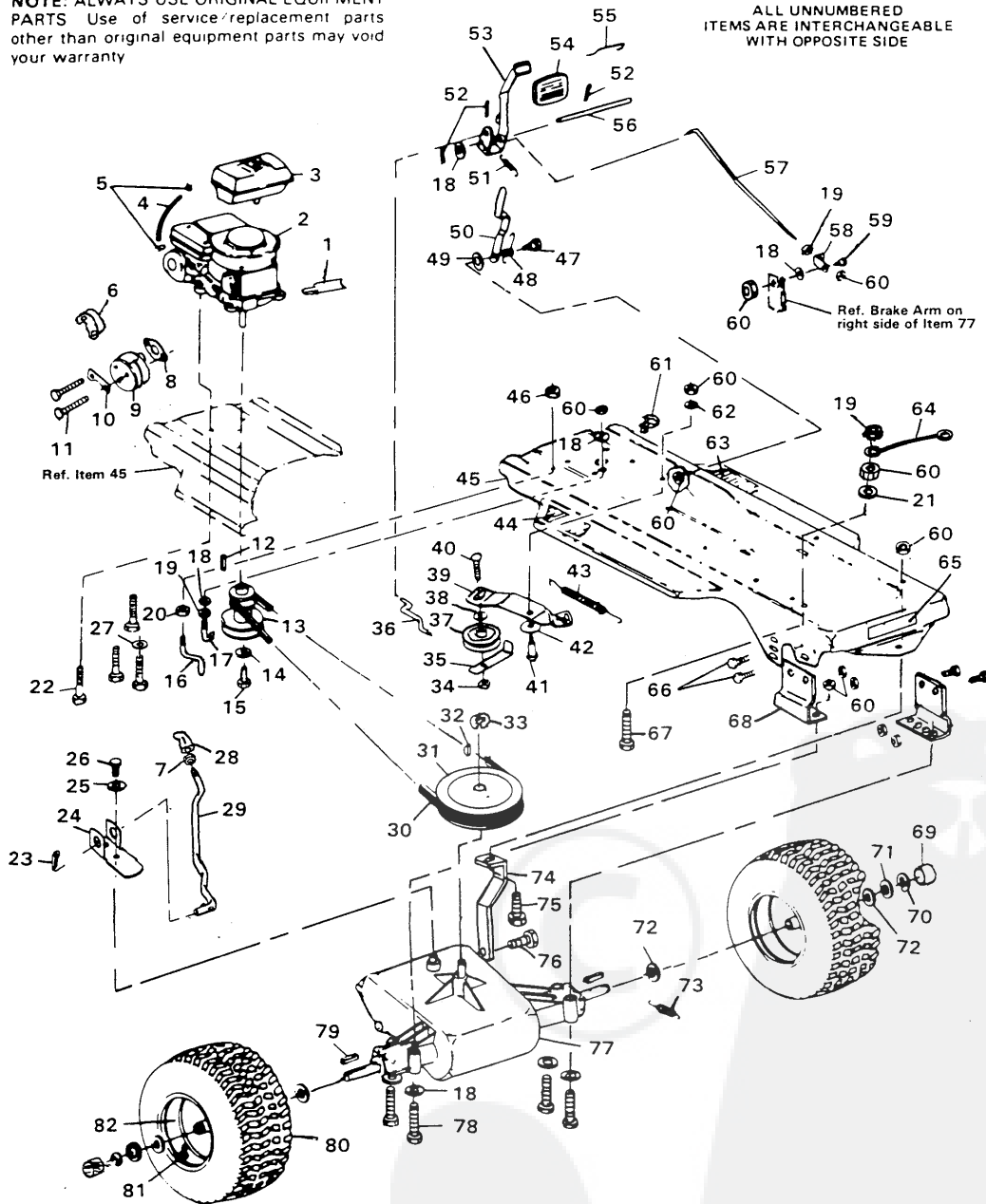



## 36" RIDING MOWER MODEL 3560-91

ALWAYS GIVE THE FOLLOWING INFORMATION WHEN ORDERING REPAIR PARTS:

1. The PART NUMBER; 2. The PART NAME; 3. QUANTITY DESIRED; 4. The MODEL NUMBER (As shown on Model Plate)

SEND PART ORDERS AS PER INSTRUCTIONS ON THE FRONT PAGE

YOUR UNIT IS RIGHT HAND (RH) OR LEFT HAND (LH) AS YOU STAND BEHIND IT.

DO NOT USE KEY NUMBERS WHEN ORDERING REPAIR PARTS. ALWAYS USE PART NUMBERS.

All replacement parts will be supplied in current production colors or in a neutral color.

A handling fee is applicable to small parts orders.

Key No.	Part No.	Description	Key No.	Part No.	Description
1	54873	Trough, Oil Drain	43	49276	Spring, Main Drive
2	Engine	§See Footnote Below	44	54955	Foot Pad, L.H.
3	48812	Gas Tank	45	56570	Main Frame
4	42258	Gas Line	46	41529	Locknut, 3/16 Thd.
5	41008	Clip, Gas Line	47	40974	Shoulder Bolt, Parking Brake
6	54767	Screw, Hex Hd, 1/4-20 x 1/2 In.	48	43968	Spring, Parking Brake
7	120238	Lockwasher, Split, 1/4 In.	49	32327	Wave Washer
8		Gasket, Muffler (Engine Part)	50	50980	Arm, Parking Brake
9	57908	Muffler	51	50562	Spring, Clutch Pedal
10		Engine Part	52	121222	Pin, Cotter, 3/32 x 3/4 In.
11	173063	Screw, Hex Hd, 5/16-18 x 3 1/2 In.	53	55722	Brake Pedal Assembly
12	33200	Key, Engine Pulley	54	53979	Rubber Pad, Brake Pedal
13	55796	Pulley, Engine	55	55025	Retainer, Pad, Brake Pedal
14	120383	Lockwasher, Split, 7/16 In.	56	43956	Shaft, Brake-Clutch Pedal
15	123567	Screw, Hex Hd, 7/16-20 x 1 In.	57	54715	Rod, Brake
16	50653	Belt Guide, Blade Drive	58	54723	Bracket, Brake Rod
17	49896	Belt Guide, Trans. Drive Belt	59	20507	Shoulder Bolt
18	120393	Flatwasher, 5/16 In.	60	9413447	Locknut, Hex 5/16-18 Thd.
19	271184	Nut, Hex, Keps, 5/16-18 Thd.	61	54888	Retainer, Wire
20	271190	Nut, Hex, Keps, 3/8-16 Thd.	62	45602	Washer
21	138485	Washer, Ext. Lock, 5/16 In.	63	54618	Foot Pad, R.H.
22	50947	Screw, Hex Hd, 3/8-16 x 1 1/4 In.	64	55511	Ground Wire
23	137185	Pin, Cotter, 1/8 x 1 In.	65	68542	Decal, Caution
24	56256	Shift Bracket	66	120228	Screw, Hex Hd, 5/16-18 x 5/8 In.
25	57157	Washer	67	122017	Screw, Hex Hd, 5/16-18 x 1 In.
26	56255	Screw, Nylock, 1/4-28 x 3/4 In.	68	53768	Bracket, Axle
27	138489	Washer, Ext. Lock, 3/8 In.	69	40394	Hub Cap
28	58284	Knob, Gear Shift	70	36625	"E" Ring
29	55526	Shift Lever	71	42815	Flatwasher
30	54758	V-Belt	72	642	Flatwasher
31	55520	Pulley, Transaxle	73	35410	Spring, Brake Return
32	3021	Key, Woodruff, No. 606	74	54713	Bracket, Stabilizer
33	22053	Retaining Ring	75	122007	Screw, Hex Hd, 5/16-18 x 3/4 In.
34	9413534	Locknut, Hex, 3/8-16 Thd.	76	35498	Screw, Hex Wa. Tap, 5/16-18 x 3/4 In.
35	39659	Belt Retainer	77	Transaxle	†Peerless 4 speed, Model 900
36	43980	Rod, Clutch	78	180112	Screw, Hex Hd, 5/16-18 x 2 3/4 In.
37	35374	Pulley, Idler	79	39628	Key, 3/16 x 3/16 x 2 1/2 In.
38	274517	Flatwasher, 25/64 In.	80	41106	Tire
39	53762	Idler Arm	81	24167	Valve Stem
40	45892	Carriage Bolt, 3/8-16 x 1 1/2 In.	82	41105	Wheel
41	41890	Shoulder Bolt	83	301077	Owner's Manual (English)
42	4107	Washer	84	301076	Owner's Manual (French)

\*Standard Hardware Items - May Be Purchased Locally.

†Contact Tecumseh/Peerless authorized service dealer for parts and warranty.

§Contact Engine Manufacturer's authorized service dealer (See Engine Manual) for parts and warranty.

36" RIDING MOWER MODEL 3560-91

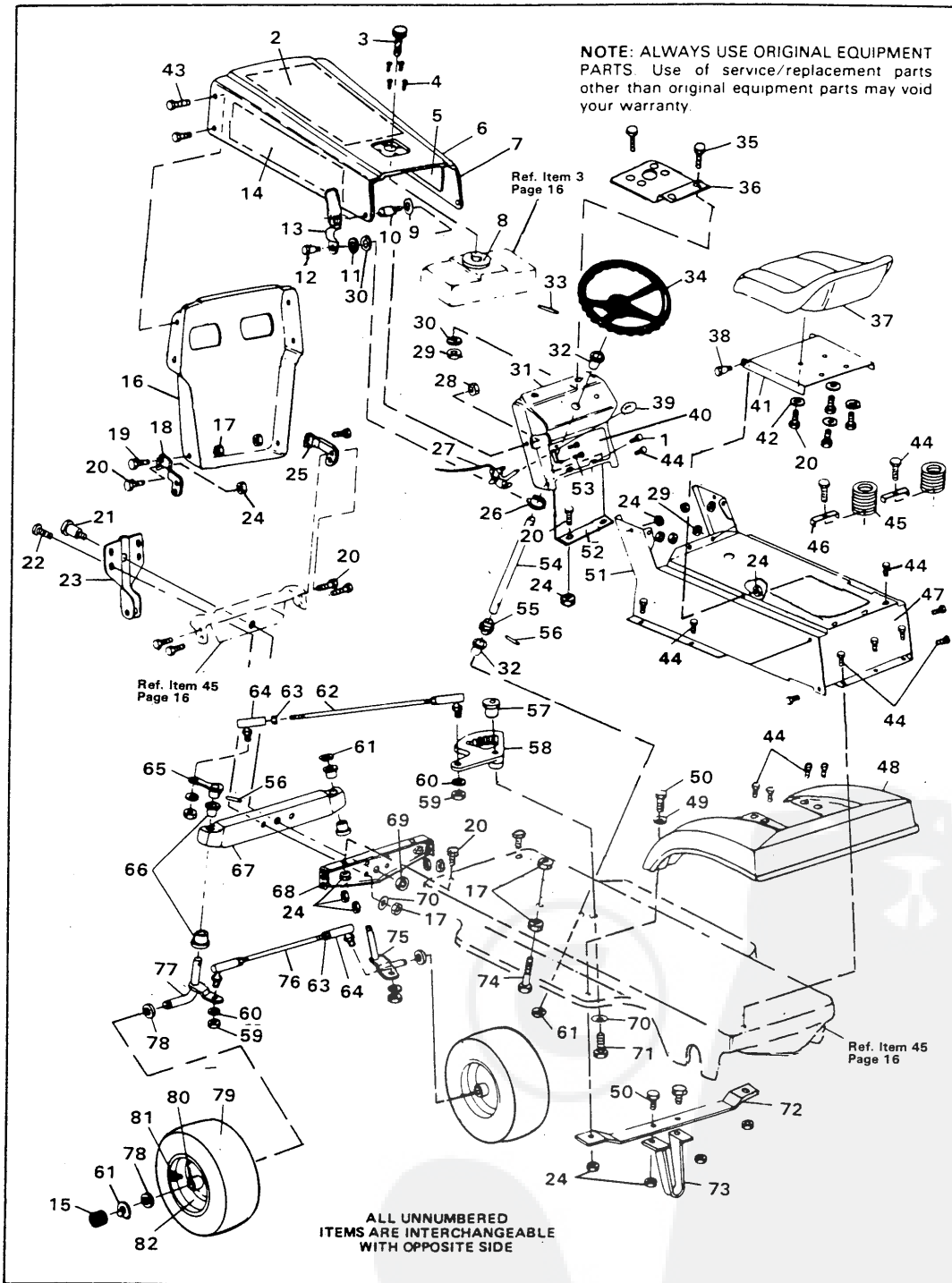

36" RIDING MOWER MODEL 3560-91

Key No.	Part No.	Description	Key No.	Part No.	Description
1	274672	Screw, Hex Wa. Hd, ¼-20 x ¾ In.	43	57215	Screw, Plastite, 5 16-9 x ¾ In.
2	55832	Foam Pad, Hood Top	44	995346	Screw, Taptite, ¼-20 x ½ In.
3	50988	Gas Gauge	45	56220	Spring, Seat
4	49050	Screw, Plastite, ¼-10 x ¾ In.	46	300284	Clip, Seat Spring
5	55834	Foam Pad, Hood, R.H.	47	56235	Cover, Rear Console
6	53954	Hood	48	52470	Fender Assembly
7	55040	Edging, Hood	49	446363	Flatwasher, 5/16 In.
8	54885	Pad, Vibration	50	122017	Screw, Hex Hd, 5/16-18 x 1 In.
9	138538	Lockwasher, Int. Tooth, 5/16 In.	51	56226	Console Assembly
10	53446	Pin, Hood Latch	52	55537	Bulkhead, Console
11	120394	Flatwasher, 13/32 In.	53	35287	Screw, Taptite, No. 8-32 x ¾ In.
12	8482	Shoulder Bolt	54	44008	Shaft, Steering
13	57159	Latch, Hood	55	44009	Pinion Gear
14	55833	Foam Pad, Hood, L.H.	56	454565	Roll Pin
15	40394	Hubcap	57	44011	Shoulder Bolt, Sector Gear
16	53402	Grille	58	48543	Sector Gear
17	9413534	Locknut, ¾-16 Thd.	59	120369	Nut, Hex, ¾-24 Thd.
18	56259	Bracket, Grille Support, L.H.	60	120382	Lockwasher, Split, ¾ In.
19	120233	Screw, Hex Hd, ¾-16 x 1 In.	61	36625	"E" Ring
20	120228	Screw, Hex Hd, 5/16-18 x ¾ In.	62	56190	Drag Link
21	50720	Shoulder Bolt, Axle Pivot	63	124925	Nut, ¾-24 Thd.
22	122201	Screw, Hex Hd, ¾-16 x 2¾ In.	64	21275	Ball Joint
23	56261	Bracket, Deck Hanger	65	49447	Arm, Steering
24	9413447	Locknut, Hex, 3/16-18 Thd.	66	50546	Bearing, Spindle
25	56260	Bracket, Grille Support, R.H.	67	56400	Front Axle Assembly
26	39492	Retaining Ring	68	56362	Bracket, Front Axle Support
27	50117	Lever, Throttle Control	69	274654	Locknut, Hex, ¼-20 Thd.
28	45174	Locknut, Wide Flange, ¼-20 Thd.	70	2483	Spring Washer
29	9424215	Locknut, Hex, ¼-20 Thd.	71	39573	Screw, Hex Hd, Lock, ¾-24 x 1 In.
30	120393	Flatwasher	72	43964	Bracket, Deck Guide Support
31	53951	Dash Assembly	73	44500	Bracket, Deck Guide
32	54902	Bearing, Steering	74	49930	Upstop Bolt
33	456836	Spring Pin, ¼ x 2¼ In.	75	55518	Spindle, Right
34	301251	Steering Wheel	76	55666	Tie Rod
35	120854	Screw, Hex Hd, ¼-20 x ¾ In.	77	55519	Spindle, Left
36	55387	Bracket, Support, Gas Tank	78	642	Flatwasher, ¾ In.
37	57500	Seat	79	41108	Tire
38	20507	Shoulder Bolt	80	39979	Bearing
39	50607	Knob, Throttle Control Lever	81	24167	Valve Stem
40	70036	Decal, Lower Dash	82	39829	Wheel w/Bearing
41	57417	Seat Bracket			
42	120638	Lockwasher, Split, 5/16 In.			

\*Standard Hardware Items - May Be Purchased Locally.

36" RIDING MOWER MODEL 3560-91

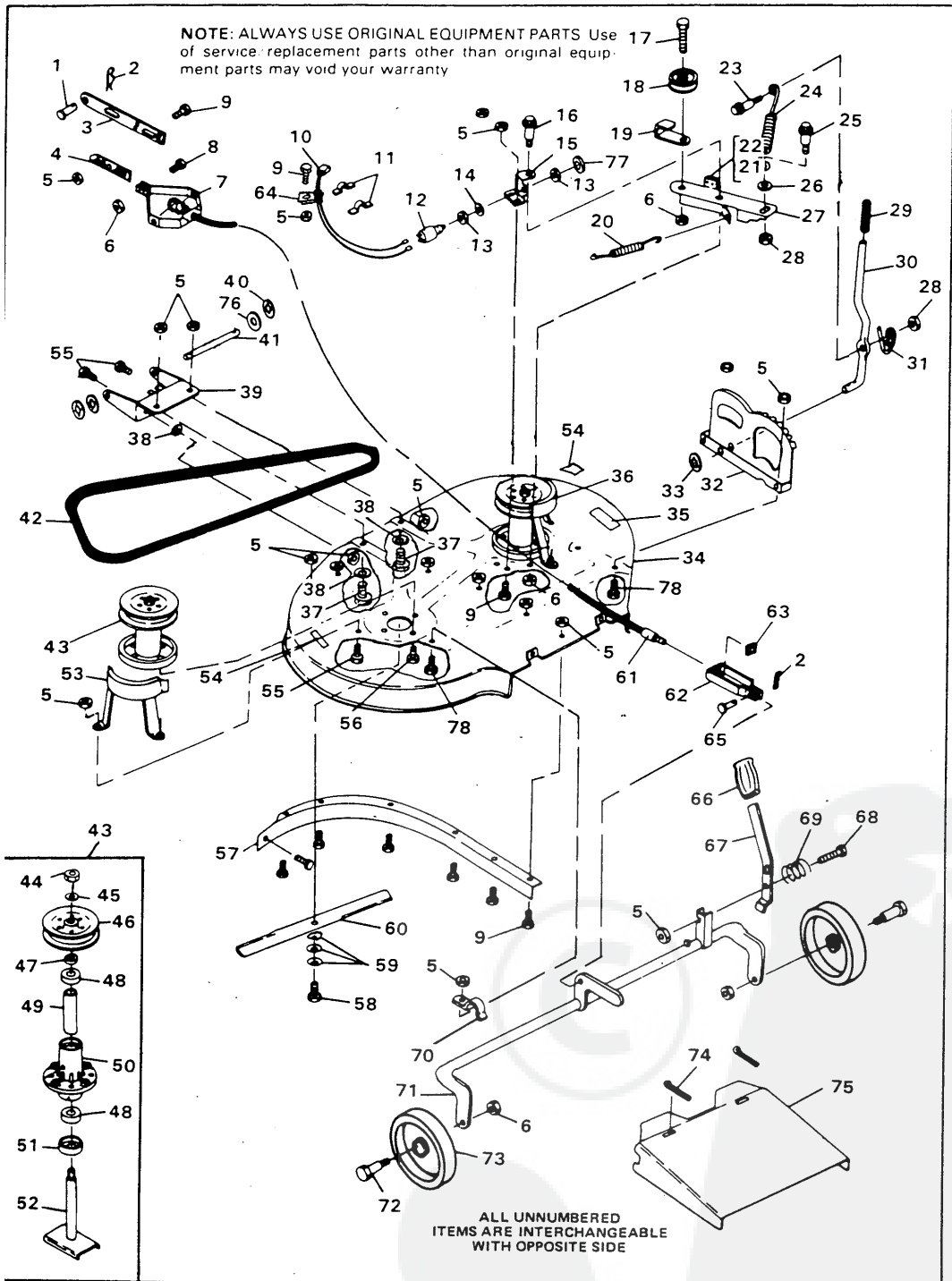



36" RIDING MOWER MODEL 3560-91

Key No.	Part No.	Description	Key No.	Part No.	Description
1	47816	Pull Pin	40	20864	"E" Ring
2	56180	Hairpin Cotter	41	55724	Pin, Pivot
3	49059	Bar Hitch	42	48044	V-Belt
4	49058	Lock Bracket	43	56424	Quill Assembly (Incl. Nos. 44-52)
5	9413447	Locknut, 5/16-18 Thd.	44	51445	Locknut, Flange
6	9413534	Locknut, 3/8-16 Thd.	45	56365	Flatwasher
7	50613	Pivot Bracket	46	56390	Pulley
8	120918	Screw, Hex Hd, 3/8-16 x 1 1/2 In.	47	51449	Spacer
9	120228	Screw, Hex Hd, 5/16-18 x 3/8 In.	48	49562	Bearing
10	48851	Wire Assembly	49	50818	Spacer, Tube
11	41482	Clip, Press	50	55547	Quill Casting
12	41204	Switch, Lockout	51	50616	Dust Shield
13	45877	Nut (Lockout Switch Part)	52	56425	Saddle and Shaft Assembly
14	45878	Lockwasher (Lockout Switch Part)	53	46365	Cover, Pulley, L.H.
15	47517	Bracket, Idler Arm	54	68542	Decal, Caution
16	47516	Shoulder Bolt	55	122017	Screw, Hex Hd, 5/16-18 x 1 In.
17	122168	Screw, Hex Hd, 3/8-16 x 1 3/8 In.	56	50634	Screw, Tapitite, 5/16-18 x 7/8 In.
18	52694	Pulley, Idler	57	55655	Baffle, L.H.
19	52695	Belt Retainer	58	39573	Screw, Hex Hd, 3/8-24 x 1 In.
20	35410	Spring	59	2483	Formed Washer
21	41601	Rivet, Brake Pad	60	56821	Blade, 18 In.
22	41471	Brake Pad	61	55880	Lift Cable
23	53696	shoulder Bolt	62	300703	Clevis, Lift Cable
24	52636	Spring, Clutch Lever	63	120372	Nut, Square, 1/4-20 Thd.
25	46563	Shoulder Bolt	64	57569	Retainer, Wire
26	120392	Flatwasher, 9/32 In.	65	39522	Pin, Clevis
27	53055	Idler Arm Assy. (Incl. Nos. 21 & 22)	66	20250	Hand Grip
28	9424215	Locknut, 1/4-20 Thd.	67	49131	Lever, Height Adjust
29	46478	Hand Grip	68	120696	Screw, hex Hd, 5/16-18 x 2 1/4 In.
30	300910	Lever, Clutch	69	53246	Spring
31	46561	Spring, Clutch Lever	70	51985	Support, Pivot Tube
32	53247	Quadrant	71	52613	Pivot Tube Assembly
33	53697	Push Nut	72	23763	Wheel Axle
34	55663	Mower Deck	73	52584	Wheel
35	68882	Decal, Height Adjust	74	120123	Pin, Cotter, 1/8 x 1 1/4 In.
36	46364	Cover, Pulley, R.H.	75	50993	Chute Extension
37	122007	Screw, Hex Hd, 5/16-18 x 3/4 In.	76	996425	Flatwasher
38	996416	Flatwasher, 3/8 In.	77	56635	Nut, Hex
39	48676	Lift Support, Plate Assembly	78	120834	Screw, Hex Hd, 5/16-18 x 1/2 In.

\*Standard Hardware Items - May Be Purchased Locally.



### 36" RIDING MOWER MODEL 3560-91

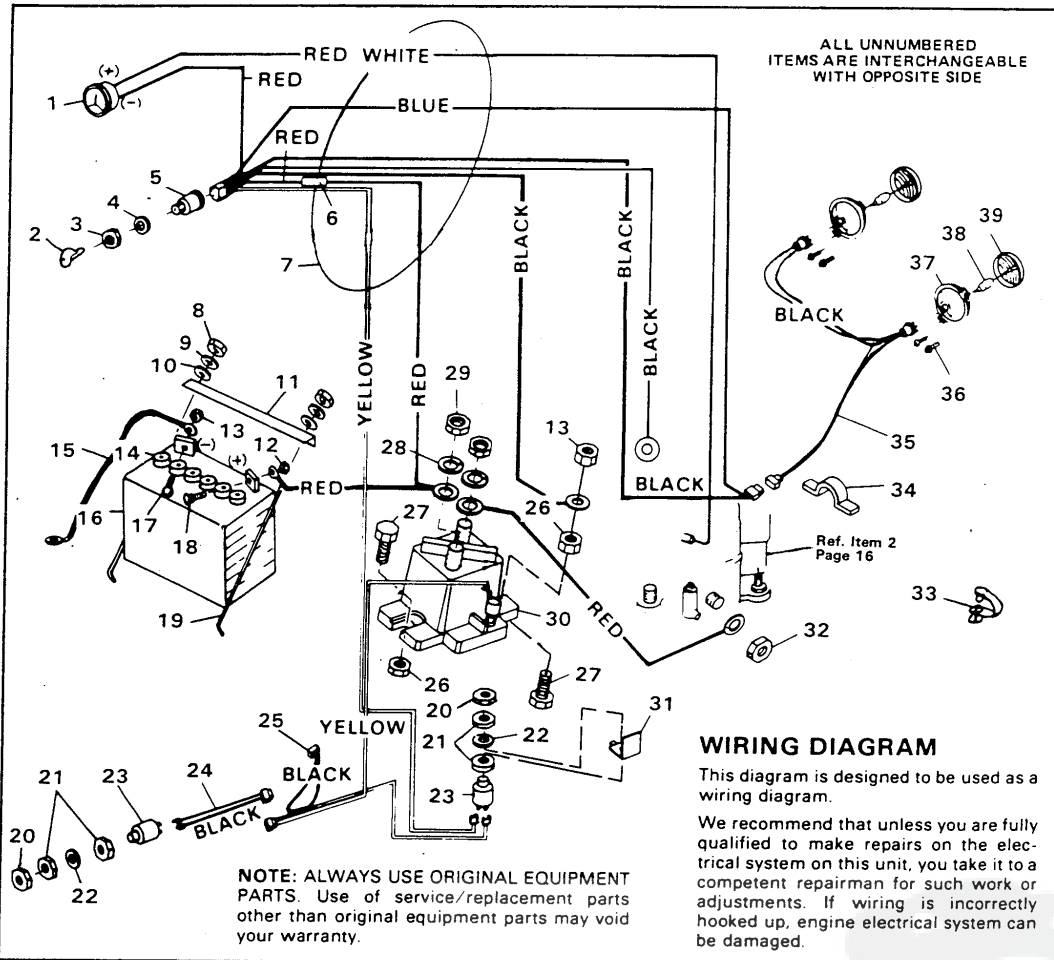

Key No.	Part No.	Description
1	39463	Ammeter
2	49643	Key, Ignition
3	48140	Locknut, (Switch Part)
4	138557	Lockwasher (Switch Part)
5	300687	Switch, Ignition
6	49211	Fuse
7	56349	Wire Harness Assembly
8	120375	*Nut, Hex, 1/4-20 Thd
9	120380	*Lockwasher, Split, 1/4 In.
10	120392	*Flatwasher, 9/32 In.
11	56360	Bracket, Battery Hold-Down
12	271184	*Nut, Keps, 5/16-18 Thd
13	271172	*Nut, Keps, 1/4-20 Thd
14	40892	Cap, Battery
15	55511	Ground Wire
16	52936	Battery
17	126203	*Carriage Bolt, 1/4-20 x 3/8 In.
18	126216	*Carriage Bolt, 5/16-18 x 3/4 In.
19	40234	Battery Rod
20	56635	Nut, Hex, 15/32-32 Thd

Key No.	Part No.	Description
21	45877	Nut (Lockout Switch Part)
22	45878	Lockwasher (Lockout Switch Part)
23	41204	Switch, Lockout
24	48851	Wire Assembly, Deck Switch
25	42071	Wire Assembly, By-Pass
26	9424215	Locknut, Hex, 1/4-20 Thd
27	187745	*Screw, Hex Hd, 1/4-20 x 3/4 In.
28	138485	Lockwasher, Ext. Tooth, 5/16 In.
29	120368	Locknut, Hex, 5/16-24 Thd
30	53716	Solenoid
31	49734	Bracket, Switch Mounting
32		Engine Part
33	54888	Retainer, Wire
34	41482	Wire Clip, Press
35	56189	Lead Wire, Headlight
36	50668	Screw, Hex Wa Hd, No. 10-14 x 1/2 In
37	52571	Bezel, Headlight
38	52572	Bulb, Headlight
39	52570	Lens, Headlight