

NOTE ALWAYS USE ORIGINAL EQUIPMENT PARTS
Use of service replacement parts other than original
equipment parts may void your warranty

ALL UNNUMBERED
ITEMS ARE INTERCHANGEABLE
WITH OPPOSITE SIDE

K E Y NO.	PART NO.	DESCRIPTION	QTY .
1	94082-853	SUPPORT GRILLE RH	1
2	94003-853	SUPPORT GRILLE LH	1
3	7 1 0 0 7 9	SCREW, 5/16-18X.75HHWATAP	4
4	94074-860	DASH	1
5	7 1 0 1 9 6	SCREW, 10-24X.500	4
6	94075	STEERING BRACKET	1
7	710197	SCREW, 1/4-14X.50PANCH ZNBKCHR	2
8	93007-860	ACCESS PANE&W/O SLOT	1
9	710282	SCREW, 1/4-14X.75 PHPANTAP	6
10	94078	C O N S O L E	1
11	710079	SCREW. 5/16-18X.75HHWATAP	4
12	94072-860	HOOD	1
13	94079-853	GRILLE	1
14	710196	SCREW, 10-24X5.00	4
15	94080	LENS. RH	1
16	94081	LENS, LH	1
17	94076	REFLECTOR, RH SINGLE	1
18	94077	REFLECTOR, LH SINGLE	2
19	710094	BOLT, SHOULDER .375 (9X51)	2
20	710140	NUT, 3/8-16 HWD FLLK (15X84)	2
21	92059	BELLOWS-STEERING POST	1
	710473	OPERATOR'S MANIJAL(NOT SHOWN)	

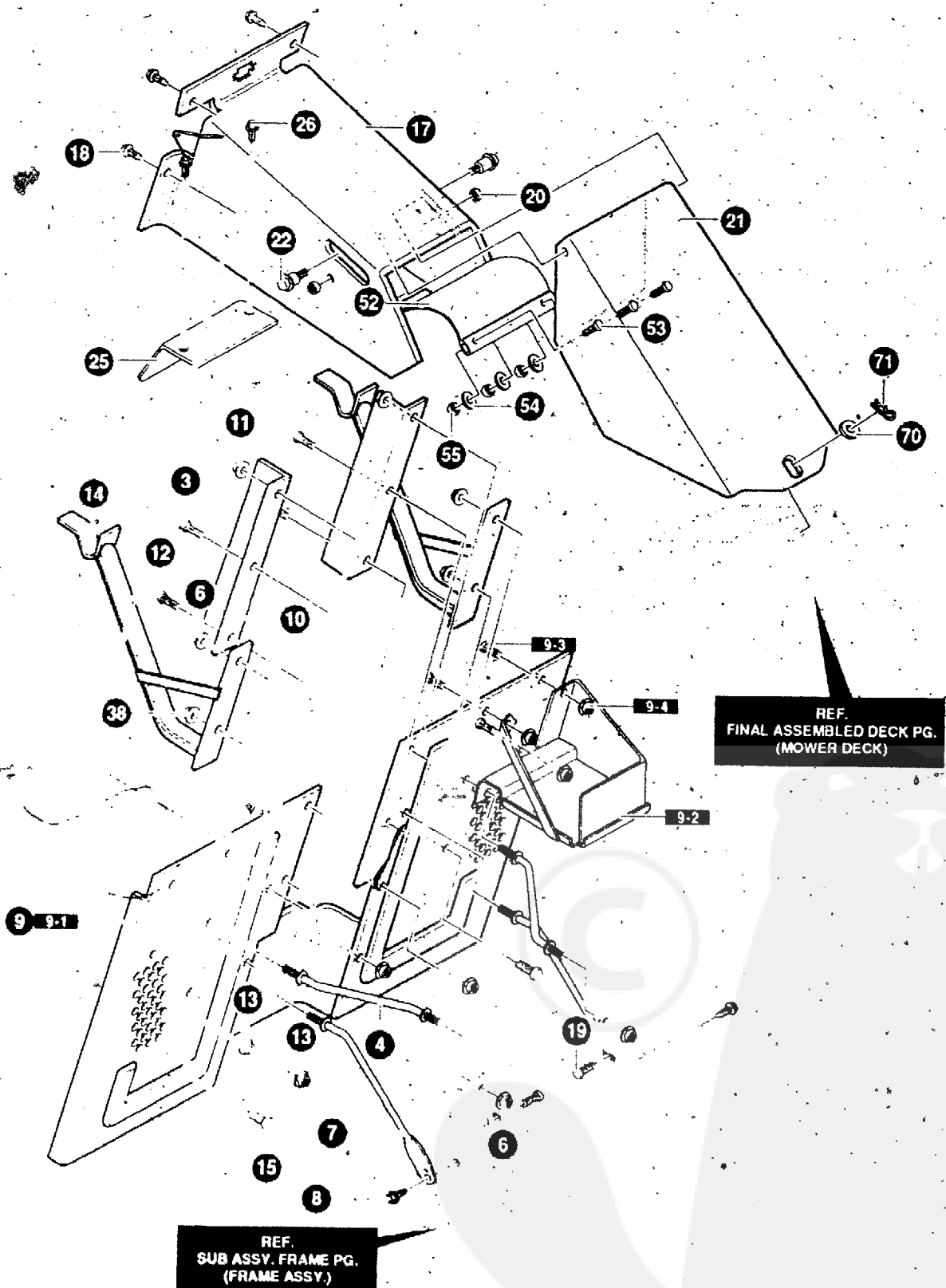

NOTE: ALWAYS USE ORIGINAL EQUIPMENT PARTS
 Use of service replacement parts other than original
 equipment parts may void your warranty

ALL UNNUMBERED
 ITEMS ARE INTERCHANGEABLE
 WITH OPPOSITE SIDE

KEY NO.	PART NO.	DESCRIPTION	QTY
3	7300.79	SCREW, 5/16-18X.75	2
4	94625	ROD; BRACE	2
6	45171	NUT, 3/8-16 HWOFL WHIZ-LOCK	4
7	94233	ROD, BRACE	2
8	710079	SCREW, 5/16-18X.75HHWATAP	2
9	341493-853	-BACK PLATE/BATTERY ASSEMBLY	1
9-1	94569	BACK PLATE ASSEMBLY	1
9-2	94563	BATTERY TRAY WELD ASM.	1
9-3	180073	SCREW, 5/16-18X.50 HHC	3
9-4	45174	NUT, 5/16-18 HEXWDFLLK WHIZ	3
10	94232-853	BRACE, BACK PLATE	2
11	45905	NUT, 3/8-16 HWDFLLK MACK	2
12	328154	SCREW, 5/16-18X1.0WDFLLK	4
13	710205	NUT, 5/16-18 WDFLLK (15X88)	4
14	94637-853	ASSY, COLLECTOR SUPPORT	2
15	328154	SCREW, 5/16-18X1.0WDFLLK	2
1	7 94295-853	CHUTE WELD ASM. UPPER	1
18	710079	SCREW, 5/16-18X.75HHWATAP	4
19	57101	BOLT, 5/16-18X.75 CARR	2
20	45174	NUT, 5/16-18 HEXWDFLLK WHIZ	2
21	94970-853	CHUTE MIDDLE ASSY	1
22	51601	BOLT, .500X.453 HHSM 3/8-16	2
25	94263-853	COVER, T-AXLE SHIELD	1
2	6 710264	SCREW, 1/4-20X.50 WAHHTAP	2
52	94264	FLAP, CHUTE REBA	1
53	180020	SCREW, 1/4-20X.75 HHC	3
54	120392	WASHER, FLAT .281X.63X.065	3
55	46931	NUT, 1/4-20 WDFL MAC-LOCK	3
70	71011'6	WASHER, FLAT .281X.63X.065 (17X103)	1
71	710108	PIN, HAIR (31X4)	1

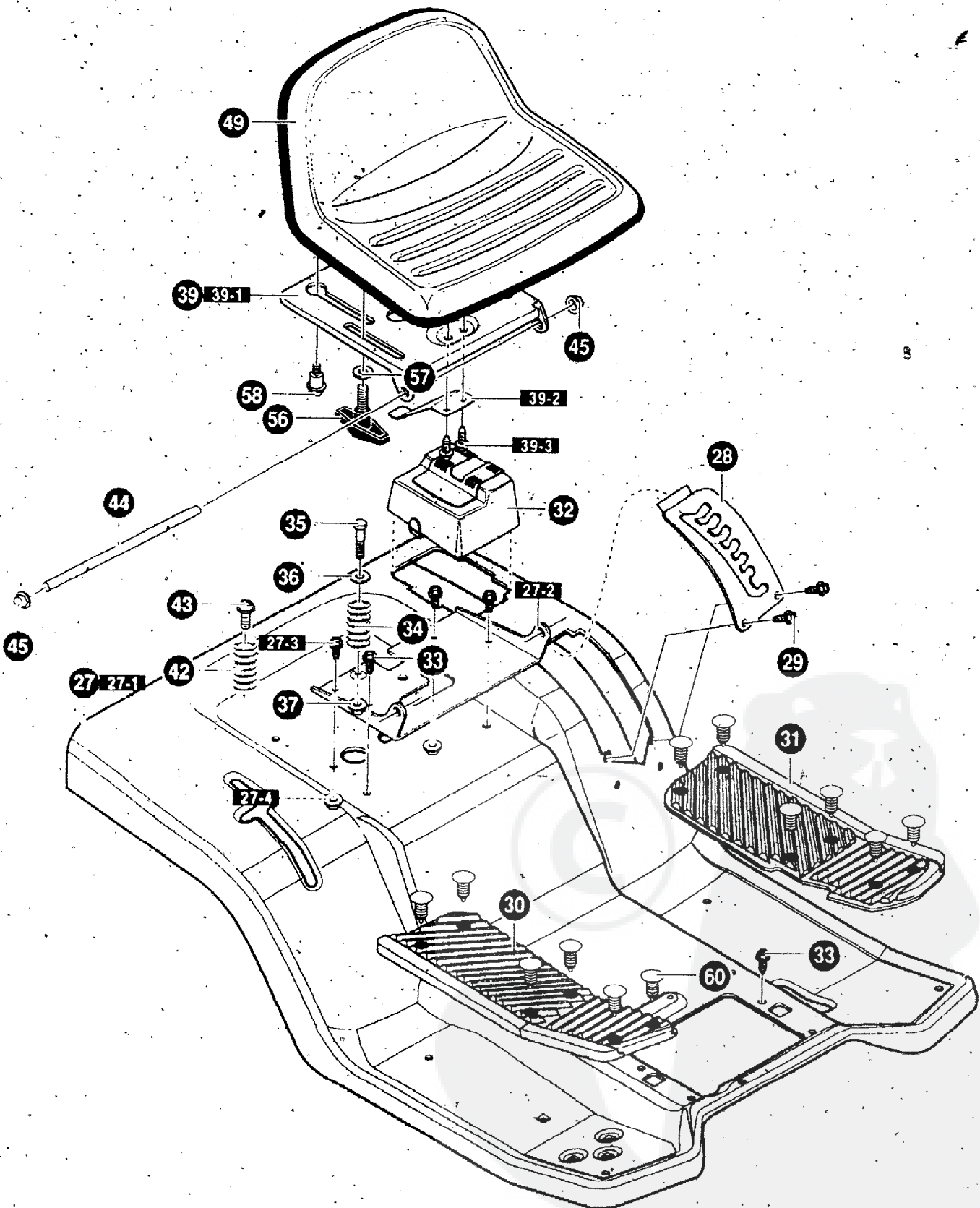

NOTE ALWAYS USE ORIGINAL EQUIPMENT PARTS
 Use of service replacement parts other than original
 equipment parts may void your warranty

ALL UNNUMBERED
 ITEMS ARE INTERCHANGEABLE
 WITH OPPOSITE SIDE

340926B

KEY NO.	PART NO.	DESCRIPTION	QTY
27	341496 -860	ASM.SEAT DECK PEDAL GEAR REBA	1
27-1	94204	SEAT DECK,GEAR DRIVE	1
27-2	94153	BRACKET, PIVOT SEAT.	1
27-3	710279	SCREW, 5/16-18X .625	2
27-4	710205	NUT, 5/16-18 WOFLLK (15X86)	2
28	94243-8'53	PLATE, LIFT DETENT	1
29	710196	SCREW, 1 0-24X.500TRSEGI	2
30	95409	FOOTREST PAD, RH	1
31	95408	FOOTREST PAD LH	1
3 2	94200	COVER, BATTERY	1
3 3	710079	SCREW, 5/16-18X.75HHWATAP	3
3 4	710136	SPRING, COMPRESS 4.57LG x 1.17	1
35	710093	BOLT, SHOULDER 1/4-20NC-2A(9X55)	1
36	94155	WASHER CUP ZINC	1
37	7 1 0 2 8 0	NUT, 114-20 WOFLLK (15X89)	1
38	45174	NUT, 5/16-18 HEXWOFLLK WHIZ	2
39	341494-860	SUB,ASM. SEAT SUPPORT REBA	1
39-1	94154	SUPPORT, SEAT	1
39-2	94057	SPRING- LEAF	1
3 9 - 3	710264	SCREW, 1/4-20X .50 WAHHTAP	2
42	7 1 0 1 0 9	SPRING, COMPRESS 2.43LG (164X30)	2
4 3	710079	SCREW, 5/16-18X.75HHWATAP	2
4 4	94156	ZINC HINGE SEAT PIVOT	1
45	710192	NUT, PUSH CAP .375 (28X23)	2
49	340927	SEAT, QK ADJUST	1
56	94160	BOLT, WING 5/16-18	2
57	710281	WASHER, FLAT.344X .62X.06	2
58	710101	BOLT, SHOULDER 5/16-18NC (9X56)	2
6 0	3 0 9 2 . 3 5	FASTENER, RATCHET	6

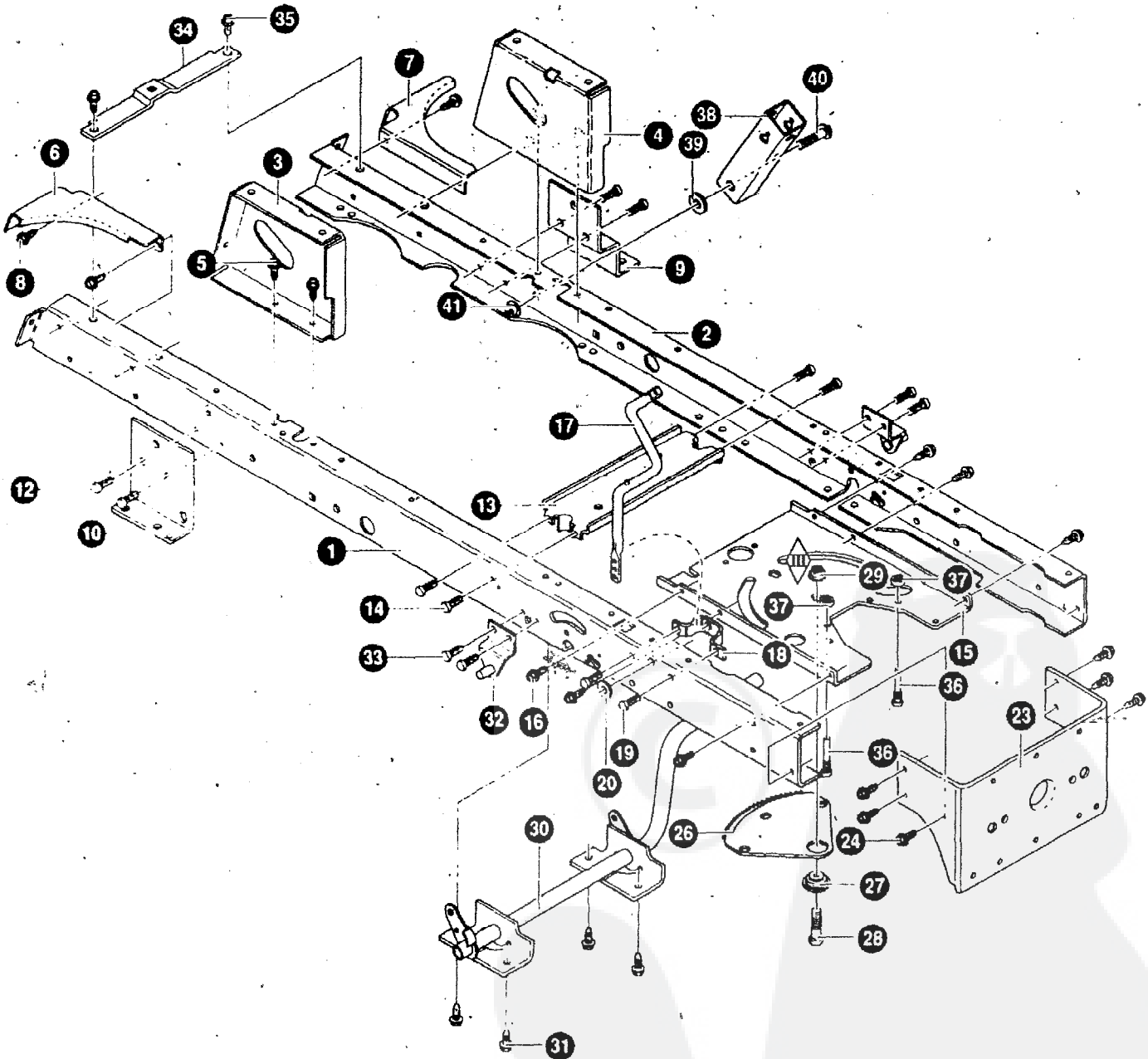

NOTE ALWAYS USE ORIGINAL EQUIPMENT PARTS
Use of service replacement parts other than original
equipment parts may void your warranty

ALL UNNUMBERED
ITEMS ARE INTERCHANGEABLE
WITH OPPOSITE SIDE

340413A

AP

KEY PART NO. NO.	DESCRIPTION	QTY
1 94564	FRAME,RAIL RH	1
2 94565	FRAME,RAIL LH	1
3 94634	SUPPORT,SEAT AH	1
4 94633	SUPPORT,SEAT LH	1
5 710079	SCREW, 5/16-18X 75HHWATAP	4
6 94561	BRACE, BACKPLATE RH	1
7 94562	BRACE, BACKPLATE LH	1
8 710079	SCREW, 5/16-18X 75HHWATAP	4
9 94234	BRACKET,T/A AH-VST,LH-MST	1
10 94235	BRACKET,TRANSAXLE RH-MST	1
12 710079	SCREW, 5/16-18X.75HHWATAP	4
13 94237	ASM. IDLER MOUNT,FRONT	1
14 710079	SCREW, 5/16-18X.75HHWATAP	4
15 94003	PLATE,STEERING MOUNTING	1
16 710079	SCREW, 5/16-18X.75HHWATAP	6
17 94019	CRANK, PTO (DRILLED)	1
18 94005	BRACKET, BELL CRANK	1
19 710079	SCREW, 5/16-18X 75HHWATAP	2
20 120395	WASHER, FLAT .469X .92X 065	1
23 94013	BRACKET, HANGER REAR	1
24 710079	SCREW, 5/16-18X.75HHWATAP	6
26 94121	GEAR, SECTOR	1
27 94123	BEARING, SECTOR GEAR	1
28 710312	SCREW, 5/16-18X1.00	1
29 710105	NUT, 5/16-18 HWDFLLK (15X113)*	1
30 94241	ASM.CLUTCH/BRAKE PEDAL	1
30-1 94037	S-ROD, BRAKE-PEDAL	1
30-2 94035	BRACKET, PEDAL PIVOT	2
30-3 94036	LEVER BRAKE PEDAL	1
30-4 94230	LEVER, BRAKE	1
31 710079	SCREW, 5/16-18X.75HHWATAP	4
32 94285	BRACKET SUSPENSION ASM.	2
33 710079	SCREW, 5/16-18X.75HHWATAP	4
34 94566	BRACE, RAIL	1
35 710079	SCREW, 5/16-18X.75HHWATAP	2
36 93349	SCREW GUIDE 5/16-18	2
37 710204	NUT,5/16-18 HEXWDFLLK WHIZ PL	2
38 94015	BRACKET, PIVOT	1
39 845	WASHER, FLAT .390X1.25X.119	1
40 710000	BOLT, .562X1.563HSH 3/8-16	1
41 710140	NUT,3/8-16HWDFLLK MACK (15X84)	1

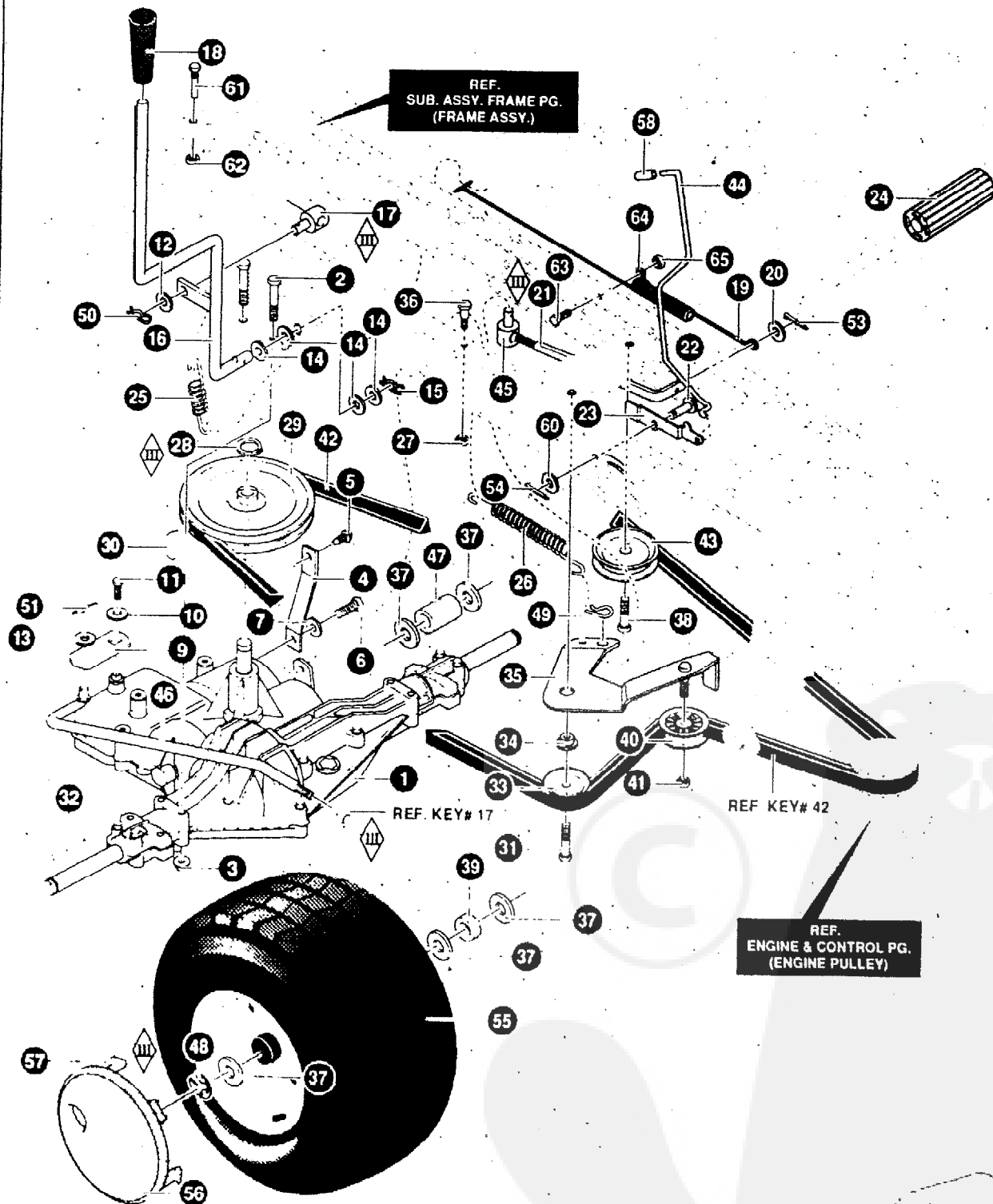

NOTE ALWAYS USE ORIGINAL EQUIPMENT PARTS
 Use of service replacement parts other than original
 equipment parts may void your warranty

ALL UNNUMBERED
 ITEMS ARE INTERCHANGEABLE
 WITH OPPOSITE SIDE

KEY NO.	PART NO.	DESCRIPTION	QTY
1		TRANSAXLE MST206-512A	1
2	180091	SCREW, 5/16-18X2 50	4
3	7 1 0 2 0 5	NUT, 5/16-18WDFLLK(15X88)	4
4	94620-853	BRACKET,STABILIZER	1
5	710079	S C R E W , 5/16-18X.75HHWATAP	1
6	35498	SCREW,5/16-18X .75 WAHHTAP	1
7	1 2 0 6 3 6	WASHER, HVSPTLK .328X.60X.09	1
9	94227	BRKT,SHIFT REBA FENDER HT	1
10	5 7 1 5 7	WASHER,.750X.250 SP-TRANSAXLE	1
11	5 6 2 5 5	S C R E W , 1/4-28X .75 NYL	1
12	2 3 0 7	WASHER, FLAT .375X .88X.125	1
13	120394	WASHER, FLAT .406X .81X.065	1
14	996425	WASHER, FLAT .515X.88X.064	4
15	56180	PIN, HAIR .53DIAX1.62LG	1
16	94242	SHIFT LEVER,MST GEAR DRIVE	1
17	21920	NUT,ADJ. 3/8-16TAP	1
18	92698	GRIP; BLACK VINYL	1
19	9 5 4 2 4	SPRING, BRAKE 35'00	1
20	3 5 2 1 4	WASHER, FLAT .328X1.06X.062	1
21	94573	ROD, CLUTCH	1
22	49332	PIN, CLEVIS .375DX.81LG	1
23	94045	LATCH, PARK BRAKE	1
24	21544	PEDAL,BRAKE/CLUTCH STD NLT	1
25	35410	SPRING .071 X .62 X 4.37	1
26	710139	SPRING, TENS .09X . X5.	1
27	780029	NUT, 1/4-20 HEXNYLOCK #71035	1
28	22053	RING, RETEX .58X.035TRU5100-62	1
2 9	94571	PULLEY. 9.0 OD V4L T/A	1
30	50795	KEY, HI-PRO 606 .75DIAX.187WD	1
31	710082	SCREW, 3/8-16X15 HHCFLTHR5	1
32	5 2 9 2 8	KEY, SQUARE 187SQX2.25LG	2
33	35374	PULLEY, IDLER V4L 3 06X .62	1
34	95423	SPACER, SHOULDER	1
35	94238-853	ASSY. IDLER ARM TRACTION	1
36	310088	BOLT,250X 312 HHSH 1/4-20	1
37	642	WASHER. FLAT .755X1 31X 075	6
38	1 8 0 1 2 4	SCREW. 3/8-16X1.25	1
39	95418	SPACER. 87 X i 25 WHEEL	2
40	91179	PULLEY	1
41	45905	NUT. 3/8-16 HWDFLLK MACK	1
42	94608	BELT, V 4L 114.12	1
43	35374	PULLEY, IDLER V4L 3 06X 62	1
44	94152	PARK BRAKE CONTROL ROD	1
45	710059	NUT. 5/16-18X3/8 ADJUSTING	1
46	94570	ROD, SHIFT LINK	1
47	95419	SPACER, 87 X 2.25 WHEEL	1
48	36625	RING, RETEX 57X.05TRU5133-75	2
49	56180	PIN. HAIR .53DIAX1.62LG	1
50	8260	PIN. HAIR .091DIAX1 66LG	1
51	121222	PIN, COTTER 090 DIAX 75LG	1
53	121222	PIN, COTTER 090 DIAX 75LG	1
54	121222	PIN, COTTER 090 DIAX 75LG	1
55	692289	TIRE & RIM 20" TURF	2
55-1	3385 12	VALVE STEM	1
55-2	338524	RIM	1
55-3	338549	TIRE	1
58	335980	CAP,DUMP VALVE ROD 25IDX 75	1
60	120394	WASHER, FLAT 406X81X065	1
61	20619	SCREW GUIDE 5/16-18	1
62	710204	NUT,5/16-18HEXWDFLLK WHIZ	1
63	180016	SCREW, 1/4-20X 50	1
64	57569	RETAINER. WIRE	1
65	51335	NUT, 1/4-20 WHIZ-LOCK	1

* CONTACT YOUR NEAREST TRANSAXLE DEALER FOR PARTS AND SERVICE

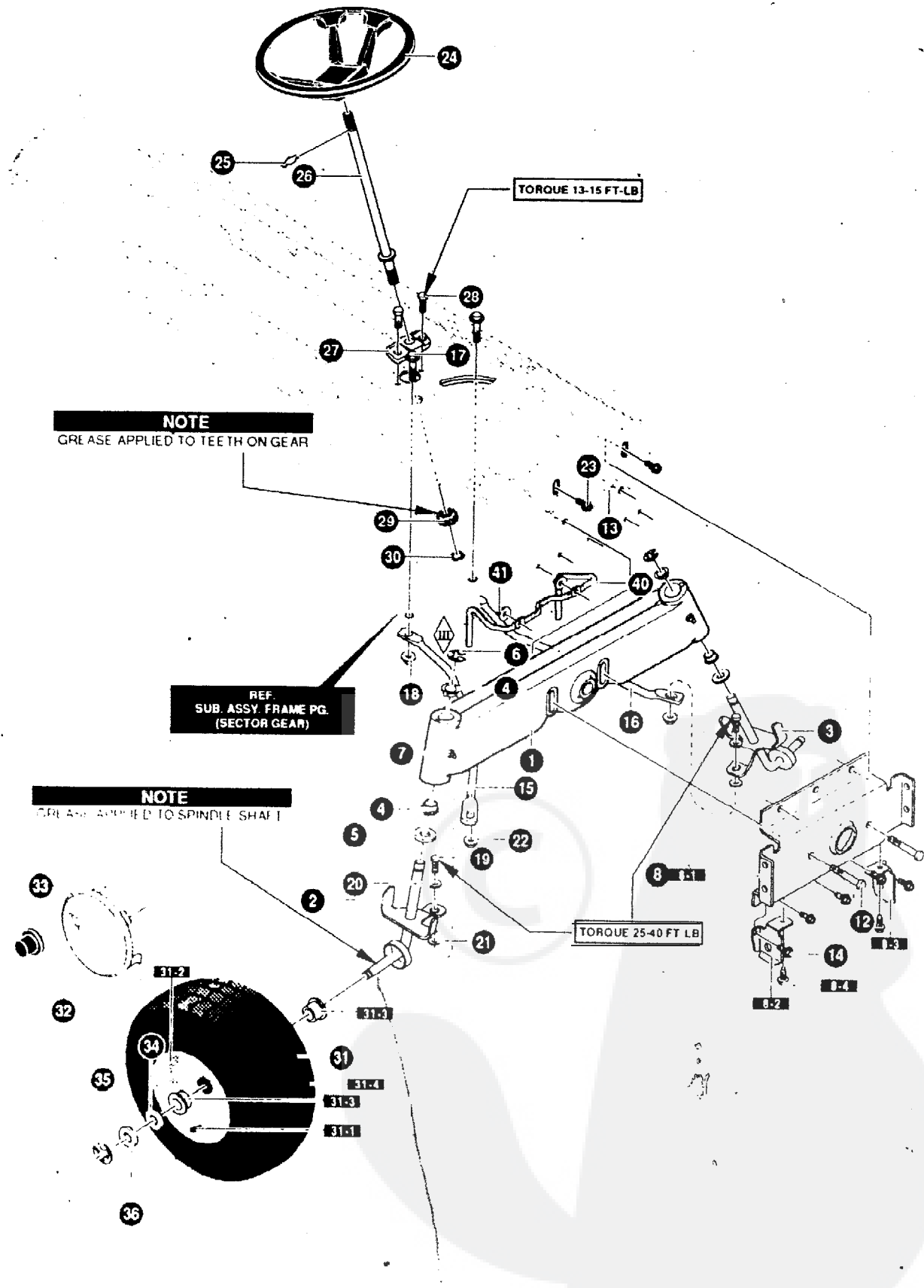

NOTE
GREASE APPLIED TO TEETH ON GEAR

REF.
SUB. ASSY. FRAME PG.
(SECTOR GEAR)

NOTE
GREASE APPLIED TO SPINDLE SHAFT

TORQUE 25-40 FT LB

TORQUE 13-15 FT-LB

NOTE ALWAYS USE ORIGINAL EQUIPMENT PARTS
Use of service replacement parts other than original
equipment parts may void your warranty.

ALL UNNUMBERED
ITEMS ARE INTERCHANGEABLE
WITH OPPOSITE SIDE

340597A

KEY NO.	PART NO.	DESCRIPTION	QTY
1	95405-853	AXLE, CAST MACHINED	1
2	94 178-853	SPINDLE, RH MO#94178	1
3	94179-853	SPINDLE LH, WELD ASSEMBLY	1
5	710129	WASHER, .766 ID X 1.62ID 16GA	2
6	710103	E-RING .574ID X .050/.750SH 11 X3	2
7	706	ZERK, GREASE FITTING	2
8	341491-853	ASM. FRONT AXLE/DECK HANGER	1
8-1	9 4 0 0 7	HANGER, AXLE	1
8-2	94290	HANGER, DECK RH	1
8-3	94289	HANGER, DECK LH	1
8-4	710079	SCREW, 5/16-18X.75HHWATAPSGIBP	2
12	180113	SCREW, 5/16-18X3.00	2
13	710205	NUT, 5/16-18 WDFLLK (15X88) Z	2
14	710079	SCREW, 5/16-18X.75HHWATAPSGIBP	2
15	94020-853	DRAG LINK, RH	1
16	94021-853	DRAG LINK, LH	1
17	710440	BOLT, HSSH (9X57)	2
18	710140	NUT, 3/8-16HWDFLLK MACK 15X84	2
19	710082	SCREW, 3/8-16X15	2
20	710083	WASHER, FLAT .391X1.00X.083	2
21	710142	WASHER, FLAT .406X.81X1.6GA	2
22	710140	NUT, 3/8-16HWDFLLK MACK 15X84 Z	2
23	710079	SCREW, 5/16-18X.75HHWATAPSGIBP	3
24	95441	STEERING WHEEL	1
26	94127	SHAFT, STEERING	1
27	94124	BEARING-LOWER	1
28	710079	SCREW, 5/16-18X.75HHWATAPSGIBP	2
29	94122	GEAR PINNION	1
30	710102	RING RET E 54ID 59SH (11 X25)	1
31	6 9 2 2 8	TIRE & RIM	2
31-1	338512	VALVE STEM	2
31-2	338517	RIM, CARLISLE	2
31-3	338513	BEARING	2
31-4	338516	TIRE, 15X6X6	2
34	710131	WASHER, FLAT 759ID (340435)	2
35	36625	RETAINING RING	2
36	710350	WASHER, FLAT 765X162X.065Z	2
40	94310	GUIDE-STACK PULLEY BELT	1
41	45174	NUT, 5/16-18HEXWDFLLK WHIZ	2

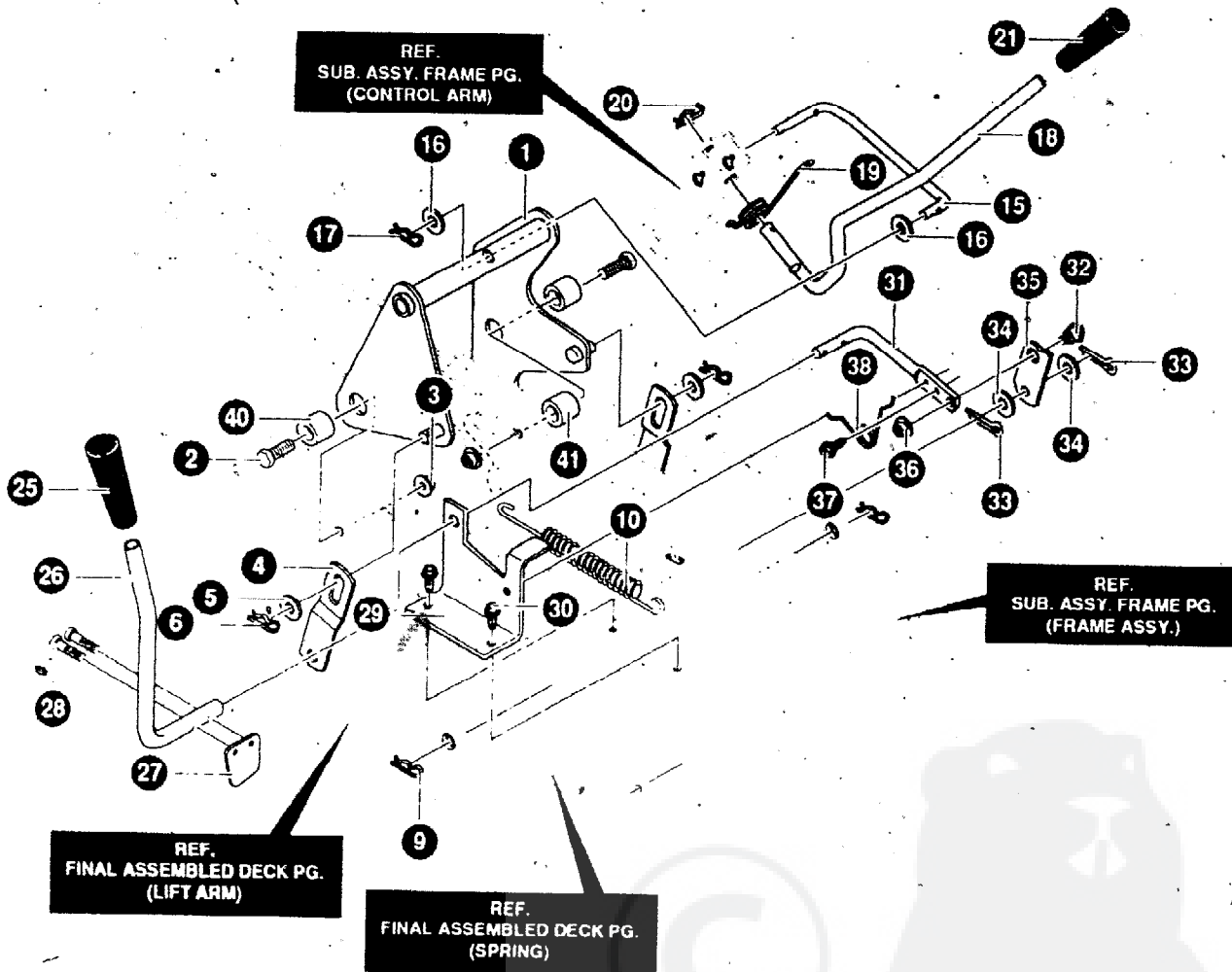

NOTE ALWAYS USE ORIGINAL EQUIPMENT PARTS
Use of service replacement parts other than original
equipment parts may void your warranty

ALL UNNUMBERED
ITEMS ARE INTERCHANGEABLE
WITH OPPOSITE SIDE

340859C

KEY NO.	PART NO.	DESCRIPTION	QTY
1	94299-853	LIFT ARM WELD ASSEMBLY	1
2	710222	SCREW, 1/2-13X1.50 (1 XI 27)	2
3	710223	NUT, 1/2-13 LOCK (15X41)	2
4	94262-853	BRACKET, LIFT LINK	2
5	710119	FLATWASHER (17X91)	2
6	710108	PIN, HAIR (31X4)	2
9	710108	PIN, HAIR (31X4)	2
1 0	710235	SPRING, EXTENSION 9 82X1.01 OD	1
15	94276	LINK; LIFT HANDLE	1
16	710119	FLATWASHER (17X91)	2
17	8260	PIN, HAIR ,091 DIA X 1 66LG	1
18	9 4 0 2 9	HANDLE, LIFT	1
19	710111	TORSION SPRING .657LG (166X40)	1
20	710108	PIN, HAIR (31X4)	1
21	9 2 6 9 7	GRIP, BLACK	1
25	92698	GRIP, BLACK	1
26	94157	PTO LEVER	1
27	94022-853	PADDLE, SWITCH	1
28	710137	SCREW, THD FORMING	2
29	940 18-853	BRACKET, PTO	1
30	710079	SCREW, 5/16-18X.75HHWATAP	2
31	94017	LEVER, PTO	1
32	710098	BOLT 50X 75 HSSH 3/8-1 6Z 9X39	1
33	710107	PIN, COTTER .094 DIA X .75 30X20	2
34	710115	FLATWASHER 518X 87X1617X102	2
35	94004	LINK PTO ZINC	1
36	710140	NUT, 3/8-16HWDFLLK MACK (15X84)	1
37	710079	SCREW, 5/16-18X.75HHWATAP	1
38	710141	TORISON SPRING .33LG (166X39)	1
40	94309	SPACER 513 ID X .880 OD	-2
41	56150	SPACER, SLEV .94X1.13X.531	1

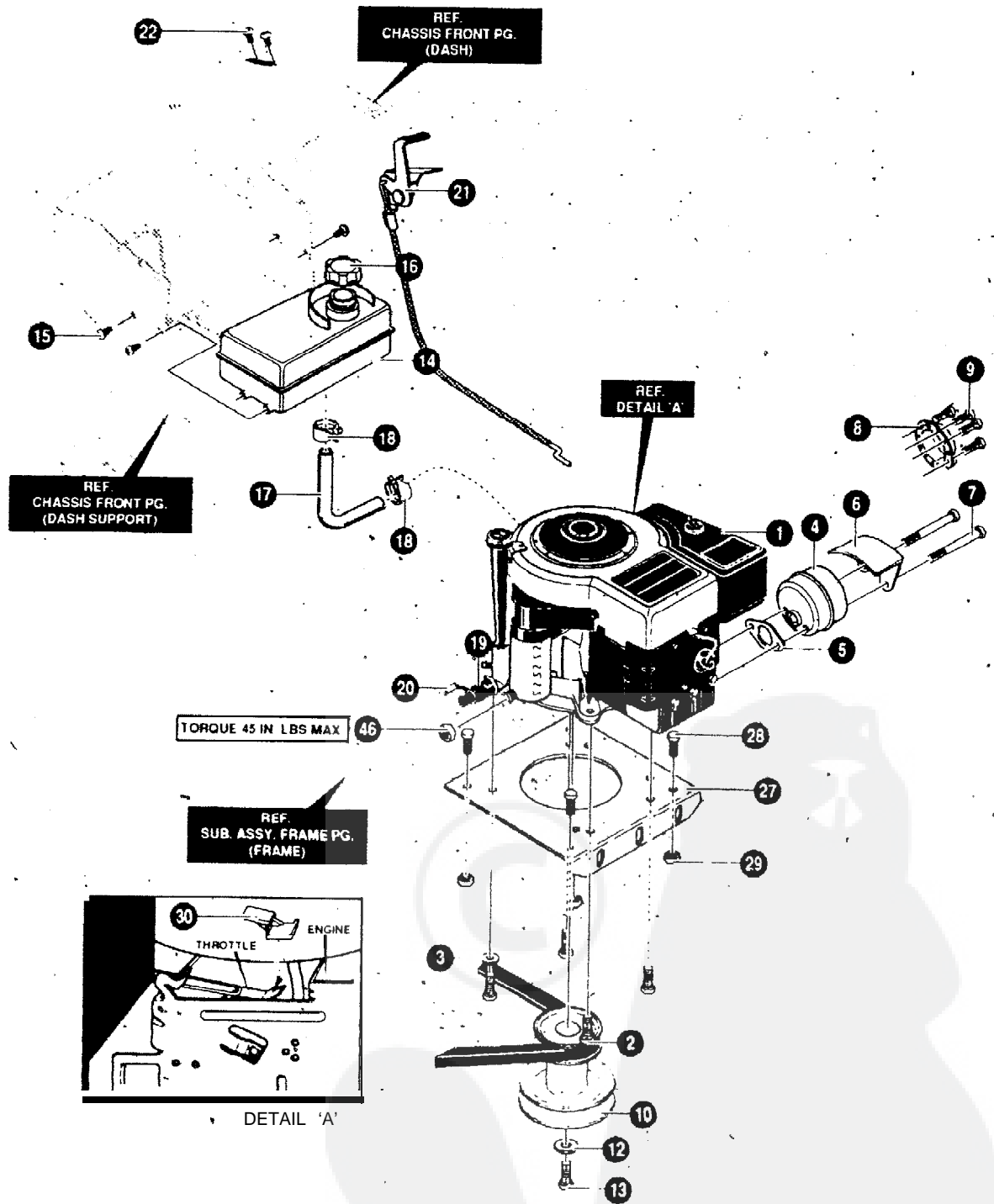

NOTE ALWAYS USE ORIGINAL EQUIPMENT PARTS
Use of service replacement parts other than original
equipment parts may void your warranty

ALL UNNUMBERED
ITEMS ARE INTERCHANGEABLE
WITH OPPOSITE SIDE

341345A

KEY NO.	PART NO.	DESCRIPTION	QTY
1	ENGINE	12-12.5HPBSIC DC (SEE ENGINE MANUAL)	1
2	50947	SCREW, 3/8-16X1.25 WAHHTAPBLKP	4
3	138489	WASHER, EXLK 384X.69X.04	1
4	91271	MUFFLER, 12 HP B&S(91271)	1
5	91309	GASKET, MUFFLER	1
6	91277	SHIELD, HEAT	1
7	710244	SCREW, 5/16-18X4.125HHC.87G5BO	2
8	23740	DEFLECTOR, EXHAUST	1
9	710267	SCREW, #8-32X.38HHWATAP BLKZ	4
10	94308	PULLEY,ENGINE 4.89X6.75X5.4OFF	1
12	120383	WASHER, REGSPTLK.459X.78X.12 Z	1
13	433146	SCREW, 7/16-20X4.25 HHC BLK PH	1
14	94073	TANK, FUEL 1.4 GALLON	1
15	710246	SCREW, 15TPI	4
16	92317	FUEL C A P	1
17	41007	TUBING, .25X.50X GAS LINE	14.50
18	9117.4	CLAMP, GAS LINE	2
19.	325547	OIL DRAIN VALVE ASSEMBLY	1
20	327422	CAP,OIL DRAIN VALVE ASM YELLOW	1
21	91989	THROTTLE CONTROL	1
22	710245	SCREW, #8-16X.38 TRCRTAPABBLC	2
27	94006-853	PLATE, ENGINE	1
28	710079	SCREW,5/16-18X 75HHWATAPSGIBP	4
29	710205	NUT, 5/16-18 WDFLLK (15X88)	4
30	94951	SPEEDREDUCER	1
46	124818	NUT, 114-20 REGHXJAM	1

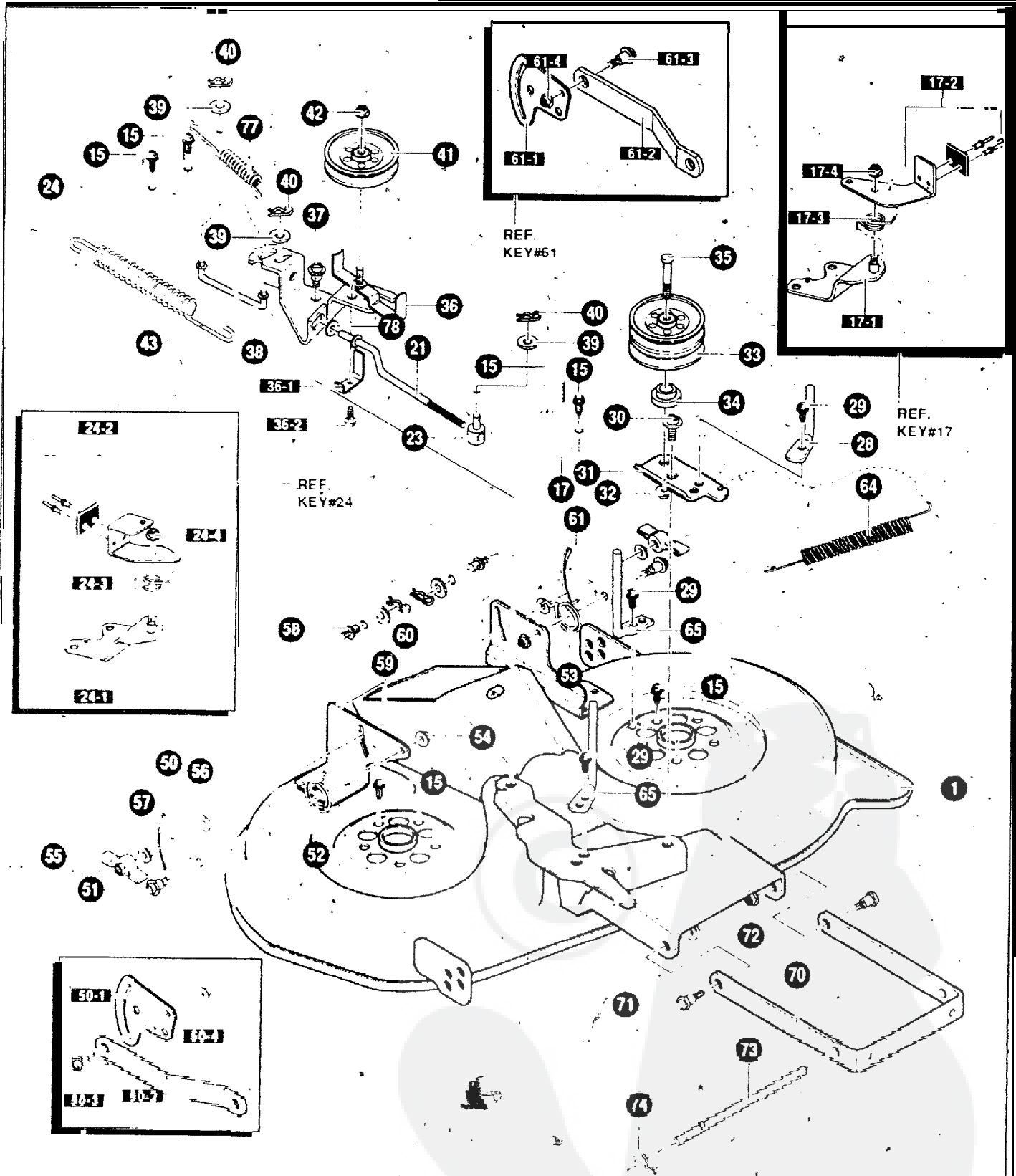

REF. KEY#61

REF. KEY#17

REF. KEY#24

REF. KEY#50

NOTE: ALWAYS USE ORIGINAL EQUIPMENT PARTS
 Use of service replacement parts other than original
 equipment parts may void your warranty.

ALL UNNUMBERED
 ITEMS ARE INTERCHANGEABLE
 WITH OPPOSITE SIDE

340977A

KEY NO.	PART NO.	DESCRIPTION	QTY
1	94303-853	WELD ASSEMBLY DECK	1
15	710265	SCREW, 3/8-16X1 .00 WAHHSPTAPPL	10
17	94665-853	BRAKE ARM ASSEMBLY LH	1
17-1	9 4 2 9 3	BRAKE SUPPORT ASSEMBLY LH	1
17-2	94291	BRAKE ARM ASSEMBLY LH	1
17-3	710110	SPRING, TORSION (166X27)	1
17-4	710205	NUT, 5/16-18 WDFLLK (15X88)	1
21	9 4 2 7 7	LINK, BRAKE LH	1
23	21920	NUT,ADJ. 3/8-1 6TAP	1
24	94664-853	BRAKE ARM ASSEMBLY RH	1
24-1	94294	BRAKE SUPPORT ASSEMBLY RH	1
24-2	94292	BRAKE ARM ASSEMBLY RH	1
24-3	710077	SPRING, TORSION	1
24-4	710205	NUT, 5/16-18 WDFLLK (15X88)	1
28	94274	GUIDE, BELT REBA	1
29	710114	SCREW, 5/16-18 .50HHTAP	3
30	710098	BOLT.50X.75 HSH 3/8-16Z 9X39	1
31	94261-853	ARM, DOUBLE IDLER	1
32	710140	NUT,3/8-16HWDFLLK MACK 15X84	1
33	94279	PULLEY, IDLER DOUBLE VEE	1
34	94269	SPACER, REBA DECK	1
35	180138	SCREW, 3/8-1 6X3.00 HHC	1
36	94973-853	IDLER ARM ASSEMBLY	1
36-1	94312	SPRING, GUIDE BELT	1
36-2	710264	SCREW, 114-20X.50 WAHHTAP	1
37	710098	BOLT.50X.75 HSH 3/8-16Z 9X39	1
38	94278	LINK, BRAKE RH	1
39	316079	WASHER, FLAT .406X .82X.040	1
40	8260	PIN, HAIR .091DIAX1.66LG	3
41	94280	PULLEY, V IDLER 4"	1
42	710140	NUT,3/8-16HWDFLLK MACK 15X84	1
43	710234	SPRING, EXTN 5.40X.714OD	1
50	341593-853	PLATE - SUSPENSION ASSY	1
50-1	94128	PLATE - SUSPENSION	1
50-2	94055	SUSPENSION BRKT REAR	1
50-3	7 10095	SHOULDER BOLT 3/8-16 (9X52)	1
50-4	710140	NUT, 3/8-16 MACK (15X84)	1
51	710094	BOLT, SHOULDER .375(9X51)	2
52	710112	SPRING, TORSION .68LG RH (166X42)	1
53	710113	SPRING, TORSION .68LG LH (166X43)	1
54	710140	NUT,3/8-1 GHWDFLLK MACK (15X84)	2
55	94068	KNOB	2
56	94137	PAD, FRICTION	2
57	710195	WASHER (17X45)	2
58	94064	PIN, HANGER	2
59	710116	WASHER, FLAT .550X1.00X11 (17X103)	2
60	710108	PIN, HAIR (31 X4)	2
61	341594	ASM. PLATE REAR SUS BRKT LH	1
61-1	94128	PLATE - SUSPENSION	1
61-2	94055	SUSPENSION BRKT REAR	1
61-3	710095	SHOULDER BOLT 3/8-16(9X52)	1
61-4	710140	NUT, 3/8-16 MACK (15X84)	1
64	710233	SPRING, EXTN 4.20X.75OD	1
65	94275	GUIDE BELT	2
70	94058-853	BRACKET, FRT SUSPENSION	1
71	710094	BOLT, SHOULDER .375(9X51)	2
72	710140	NUT,3/8-1 GHWDFLLK MACK (15X84)	2
73	94158	ZINC, ROD, HANGER	1
7 4	710108	PIN, HAIR (31X4)	1
77	710658	SPRING, EXTENSION	1
78	996416	WASHER, FLAT .391X1.00X.125	1

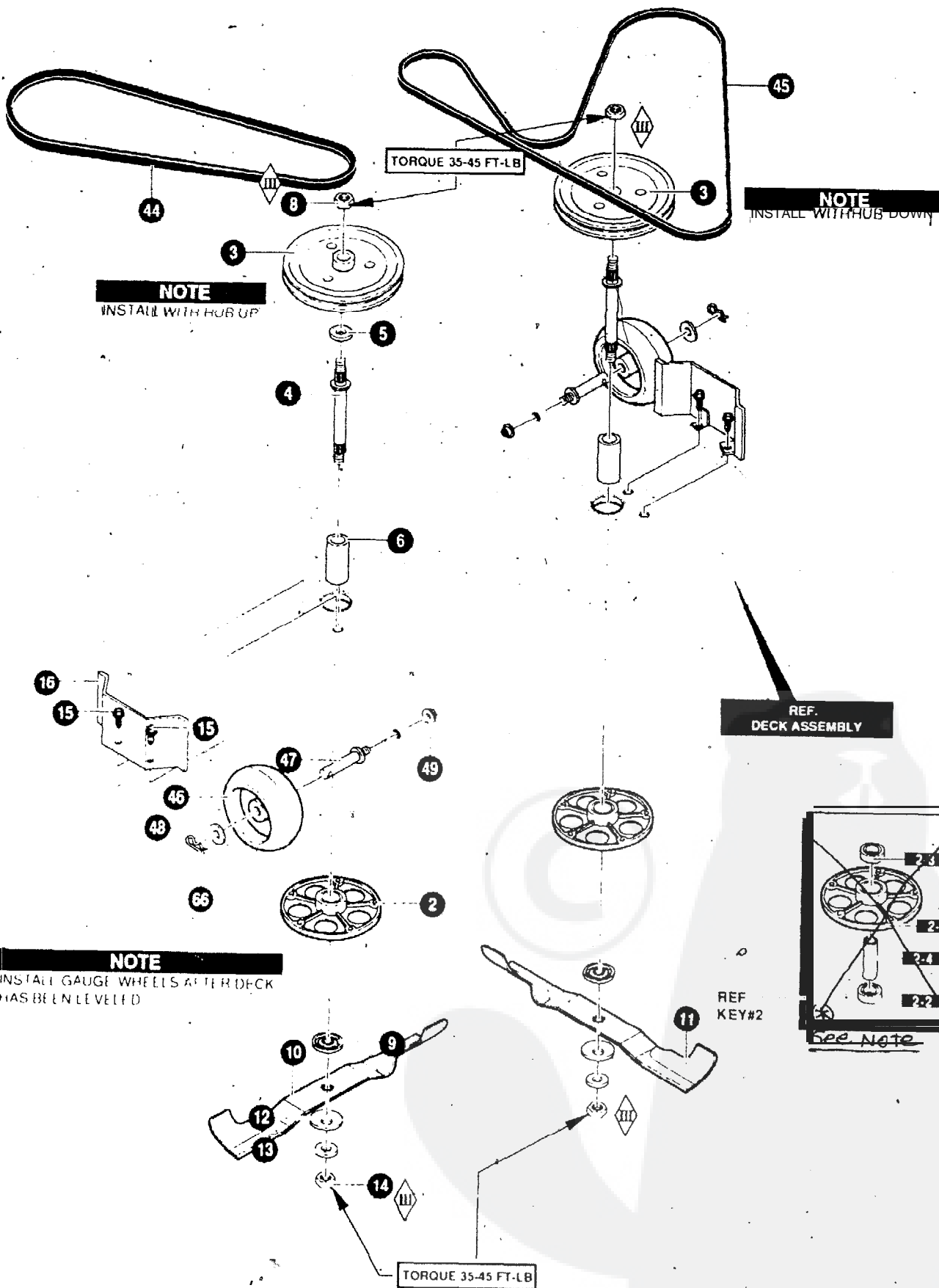

NOTE ALWAYS USE ORIGINAL EQUIPMENT PARTS
Use of service replacement parts other than original
equipment parts may void your warranty.

ALL UNNUMBERED
ITEMS ARE INTERCHANGEABLE
WITH OPPOSITE SIDE

KEY NO.	PART NO.	DESCRIPTION	QTY	
2	94305	ASM.JACKSHAFT HOUSING W/VENTS	2	
* see Note (*) {	94282	HOUSING, JACKSHAFT	1	
	92282	BRNG, LOWER JACKSHAFT	1	
	92281	BRNG, UPPER JACKSHAFT	1	
	90904	SPACER, REBA JACKSHAFT	1	
3	92425	PULLEY, DECK REBA	2	
4	9 1 9 2 2	JACKSHAFT, 7.76LG-9/16-18TH	2	
5	710117	WASHER,FLAT .625X1.00X.188	1	
6	91903	SPACER	2	
80	94207 710408	NUT, 9/16-18 CTLK (15X101)	2	
		ADAPTER, DECK/BLADE	2	
	94208	BLADE, 40" RH REAR DISCHARGE	1	
	94209	BLADE, 40" LH REAR DISCHARGE	1	
5	12	710118	WASHER, FLAT.625X1.75 17X166	2
	13	710117	WASHER,FLAT .625X1.00X.188	2
	14	710104	NUT, 9/16 REGHEX (15X100)	2
	15	710265	SCREW, 3/8-16X1.00 WAHHSPTAPPL	10
	16	94288-853	C O V E R P U L L E Y	2
	44		BELT, V	1
	45	710231 710232	BELT, V- 40" DECK	1
	46	92663	GAUGE WHEEL,4.94 DIA.	2
	47	94025	BOLT, SPSH 3/8-16X.63SH3.00LG	2
	-48	710115	WASH ER,FLAT.518X.87X1617X102	2
	49	710140	NUT,3/8-16HWDFLK MACK 15X84	2
	66	710108	HAIR PIN (31X4)	2

NOTE:

(*) These individual parts will NOT be available.

Must order the complete assembly; Part No. 94305.

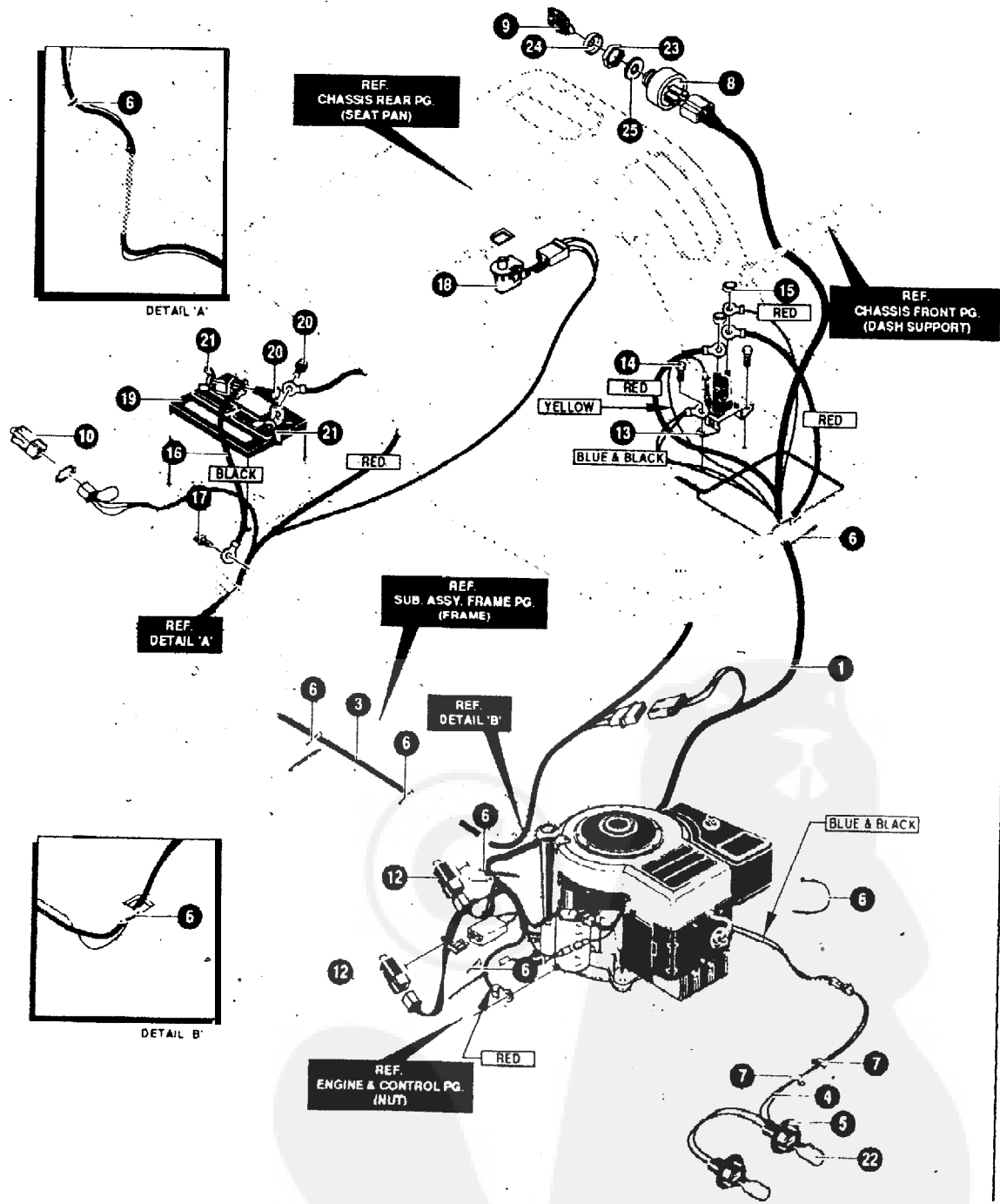

KEY NO.	PART NO.	DESCRIPTION	QTY
1	94751	HARNES 12.5885	1
3	94742	HARNES, REAR-BATTERY	1
4	94780	WIRE ASSEMBLY, HEADLIGHT	1
5	92372	SOCKET	2
6	57444	TIE, CABLE BLACK NYLON 5.62L	5
7	41482	PRESS CLIP,1.380LG.255ID	2
8	94878	SWITCH, IGNITION DELTA 7 TERM	1
9	327350	KEY,IGNITION	1
10	320082	SWITCH,DOUBLE POLE NO/NC GRAY	1
12	94136	SWITCH LIMIT DELTA 6400-84	2
13	94613	SOLENOID	1
14	710133	SCREW,HHWATAP 1/4X.50 Z REV'BH	2
15	710203	NUT, 1/4-20 HEXNYL 15X116	2
16	95420	WIRE, GROUND, 20.0"	1
17	710133	SCREW,HHWATAP 1/4X.50 Z REV'BH	1
18	94159	SWITCH, SEAT	1
19	302257	BATTERY, 12 VOLT7 PLATE	1
20	710226	BOLT,1/4-20X.63CAR (2X82)	2
21	710225	NUT, WING 1/4-20 NC (14X79)	2
22	90084	BULB, LIGHT MO 90084	2
23	327352	NUT, 5/8-8 ACME DELTA FOR BOOT	1
24	300194	BOOT, IGN SWITCH	1
25	138557	WASHER, REGINTLK.640X1.1X.05	1

WIRING SCHEMATIC

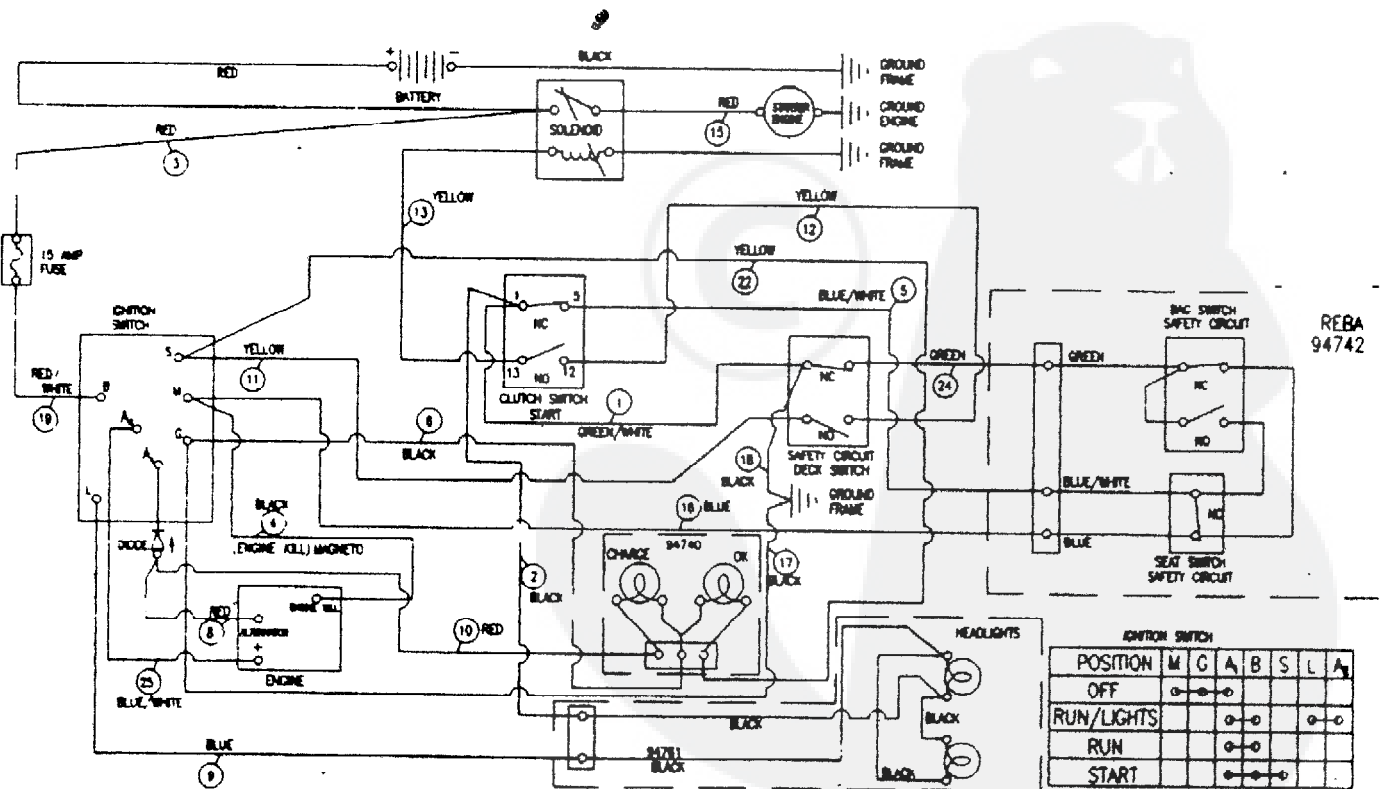

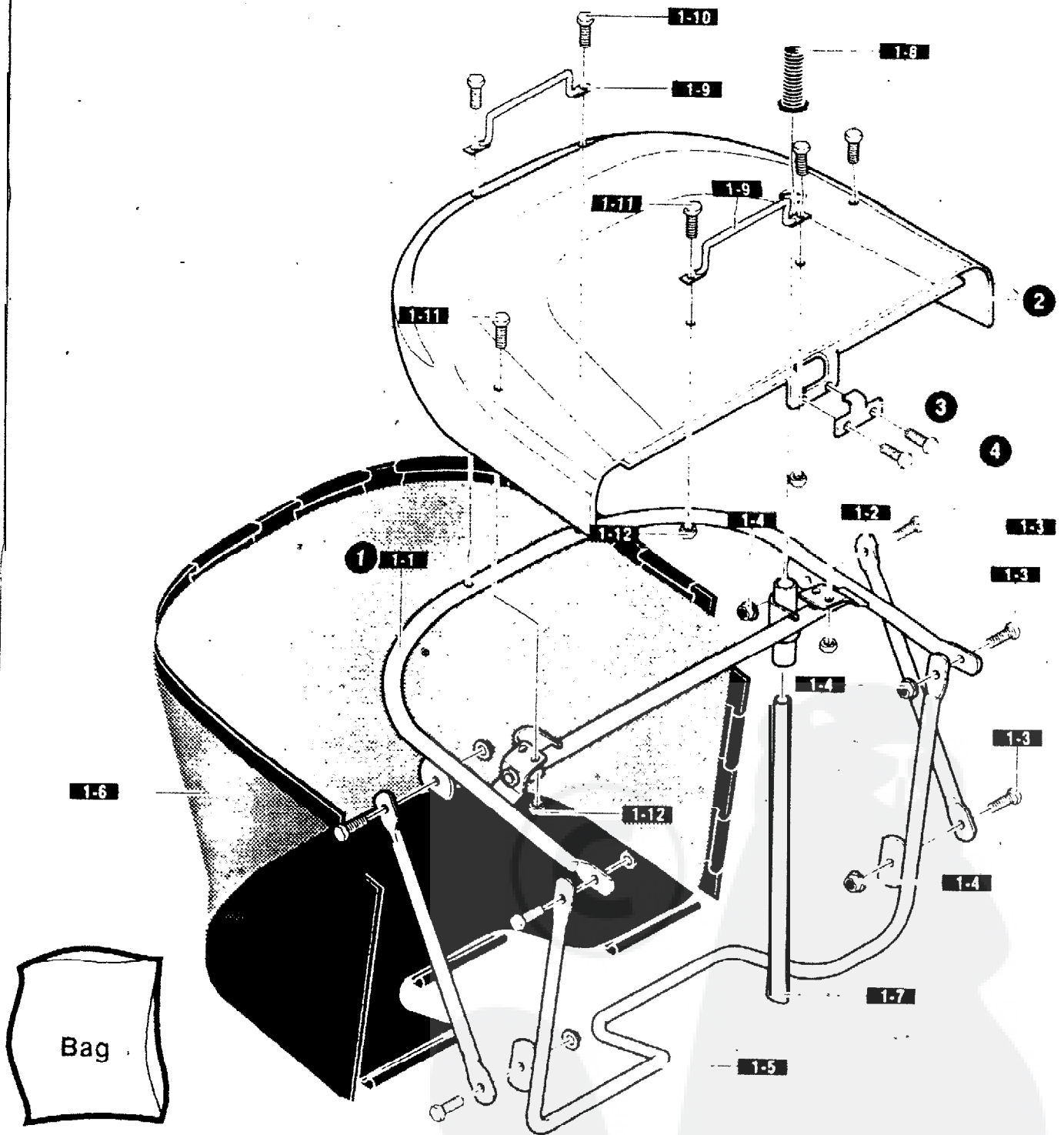

K E Y NO.	FART NO.	DESCRIPTION	QTY
1	94560	ASM.GRASS COLLECT& REBA	1
1-1	94849	ASSY., UPPER FRAME	1
1-2	94850	BRACE, FRAME COLLECTOR	2
1-3	180020	SCREW, 1/4-20X.75	6
1-4	1502	NUT, 1/4-20 REGHEXCTRLK	6
1-5	94851	ASSY., FRONT FRAME COLLECT	1
1-6	94852	BAG, REBA COLLECTOR	1
1-7	94853	HANDLE, DUMP REBA COLLECT	1
1-8	94854	RUBBER GRIP 7/8"REBA	1
1-9	94855	HANDLE, REBA COLLECTOR	2
1-10	710266	SCREW, 10-24X.38 SLHWATAP	2
1-11	710266	SCREW, 10-24X.38 SLHWATAP	4
1-12	308459	NUT, #10-24 HXHDNYLK	4
2	94908-860	TOP COVER, COLLECTOR REBA	1
3	94244	BRACKET, SWITCH	1
4		RIVET. POP .187DIA X 450LG (NON SERVICEABLE PART)	2

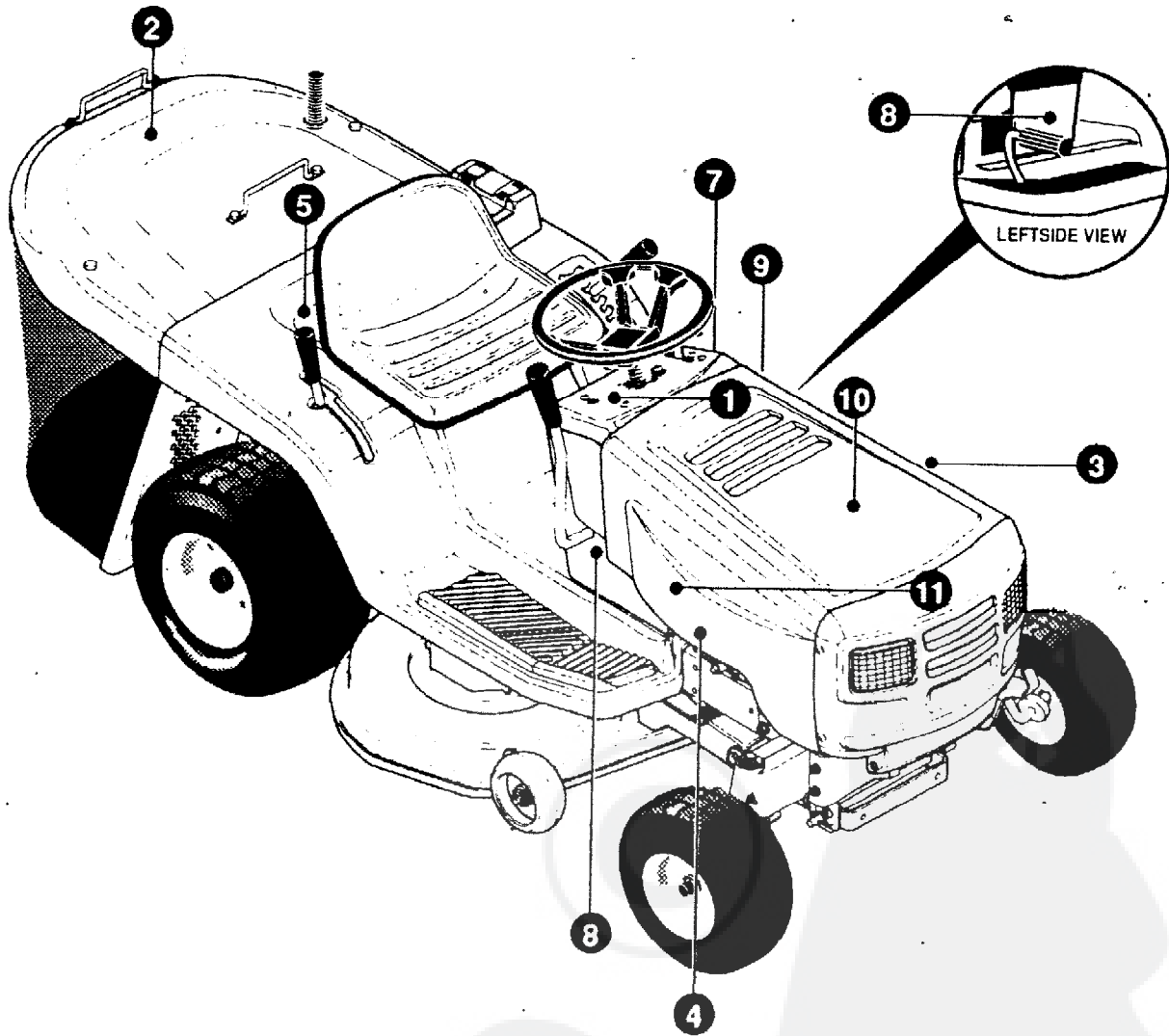

KEY NO.	PART NO.	DESCRIPTION	QTY
1	710739	DECAL, DASH PANEL MO#44X6817	1
2	710742	DECAL, MURRAY BAGGER TOP	1
3	710681	DECAL, MURRAY 125 LH HOOD	1
4	710680	DECAL, MURRAY 125 RH HOOD	1
5		NOT A SERVICEABLE PART	
7	710740	DECAL,GAS GAUGE LT SIDE CONS	1
8	710737	DECAL, BRIGGS LOGO LT/RT CONS	2
9	710741	DECAL,3/WAY CUTTING DECK	1
10	55832	PAD, FOAM TOP HOOD	1
11	305603	PAD, 18X6 FOAM HOOD	2

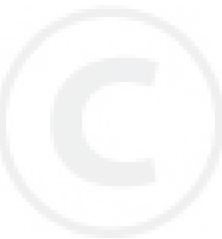

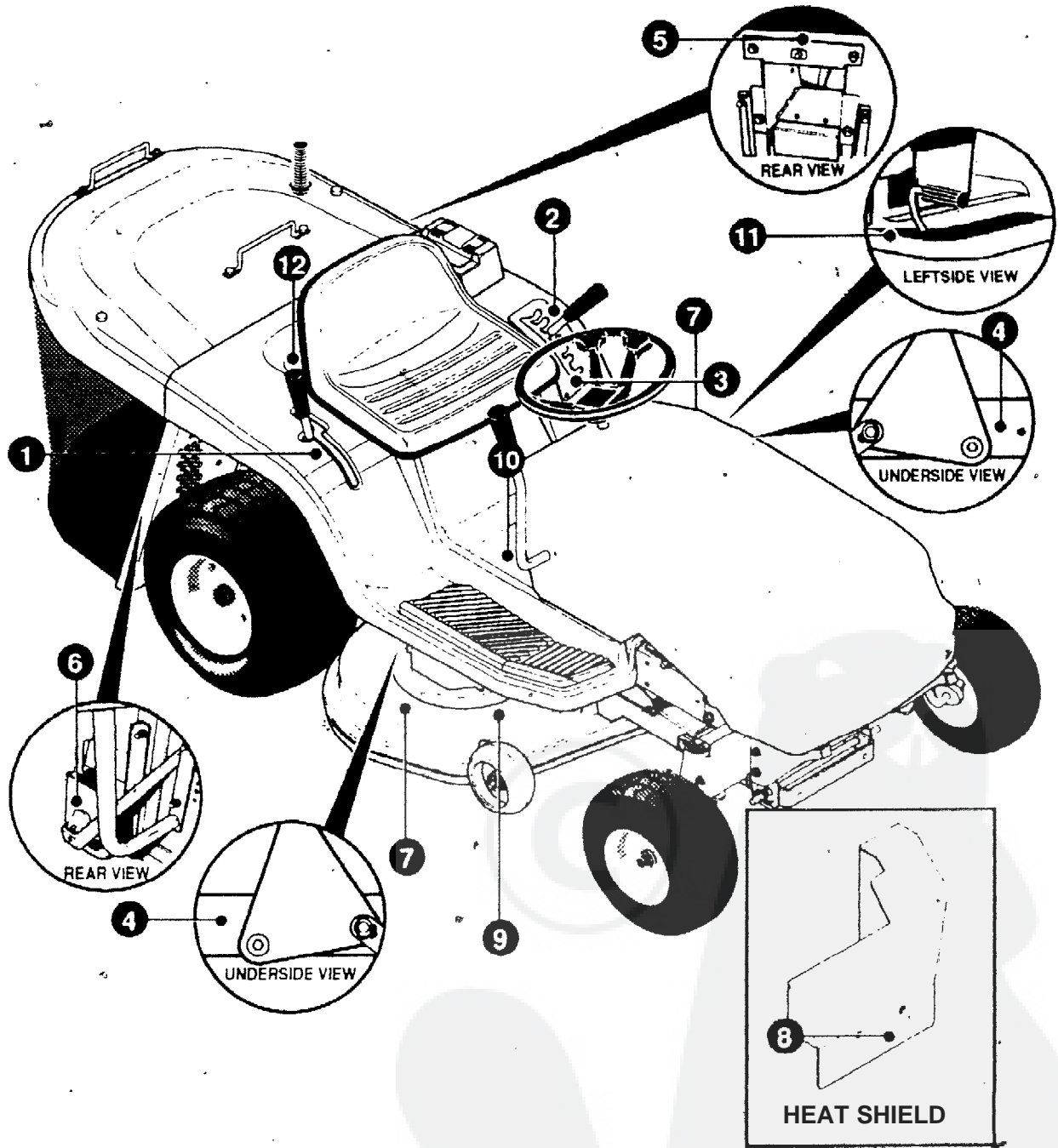

KEY NO.	PART NO.	DESCRIPTION	QTY
1	710558	DECAL, SHIFTER 6-SP REBA	1
2	710517	DECAL, HEIGHT ADJUST 6-POS	1
3	710683	DECAL, DECK LEVEL REBA/NLT EXP	1
4	710523	DECAL, PINCH POINTS WARNING	1
5	338541	DECAL, BAGGER "CE" M#44X5939	7
6	333542	DECAL, DRAWBAR WARNM#44X6138	1
7	402700	DECAL, CAUTION DECK LH	2
a	338543	DECAL, HOT SURF WARNM#44X5936	1
9	710684	DECAL, DECK BELT ROUTE REBA	1
10	710534	DECAL, CONS CAUT. M#44X6815	1
11	402702	DECAL, BRAKE/CLUTCH PICTOGRAM	1
12	318010	DECAL, TUV GSMO#44X2929	1

