

REF.
CHASSIS REAR PG.
(SEAT DECK ASSY.)

NOTE: ALWAYS USE ORIGINAL EQUIPMENT PARTS.
Use of service/replacement parts other than original
equipment parts may void your warranty.

ALL UNNUMBERED
ITEMS ARE INTERCHANGEABLE
WITH OPPOSITE SIDE

3413175

KEY NO,	PART NO.	DESCRIPTION	QTY
1	95432-853	BRACKET/HOOD RH	1
2	95433-053	BRACKET/HOOD LH	1
3	710079	SCREW, 5/16-18X.75HHWATAPSGIBP	4
4	95427	DASH	1
5	710282	SCREW, 1/4-14X.75PHPANTAPABBL	2
8	180020	SCREW, 1/4-20X.75 HHC	2
9	120392	WASHER, FLAT .281X .63X.065	4
10	780029	1/4-20 HEX NYLOCK NUT #71035	1
11	341569-836	ASM.LOWER CONSOLE	1
11-1	95425	TOWER,LOWER DASH	1
11-2	95426	SUPPORT,STEERING/PTO NLT	1
11-3	710264	SCREW, 1/4-20X.50 WAHHTAP	4
11-4	95406	ROD,DASH BRACE(H14-H15)	1
11-5	710264	SCREW, 1/4-20X.50 WAHHTAP	2
12	710079	SCREW, 5/16-18X.75HHWATAPSGIBP	4
15	94638-836	PANEL, ACCESS	1
16	710196	SCREW, 1/10-24X .500	2
17	94977	HOOD	1
18	302670	LENS,HEADLAMP	1
19	308492	FOIL,LENS REFLECTOR,	1
20	322700	DECAL,TAPE H14 8MIL VINYL	1
21	301452	FOIL, HEAT REFLECTOR	2
22	300317	PIN, CLEVIS .375DIA.X1.64LG	2
23	710343	PIN, HAIR .38DIA X1.66LG	2
24	6711	WASHER, PLASTIC .315X .75X.064	4
25	95404	BUSHING,STEERING SHAFT	1
	711115	OPERATOR'S MANUAL (NOT SHOWN)	

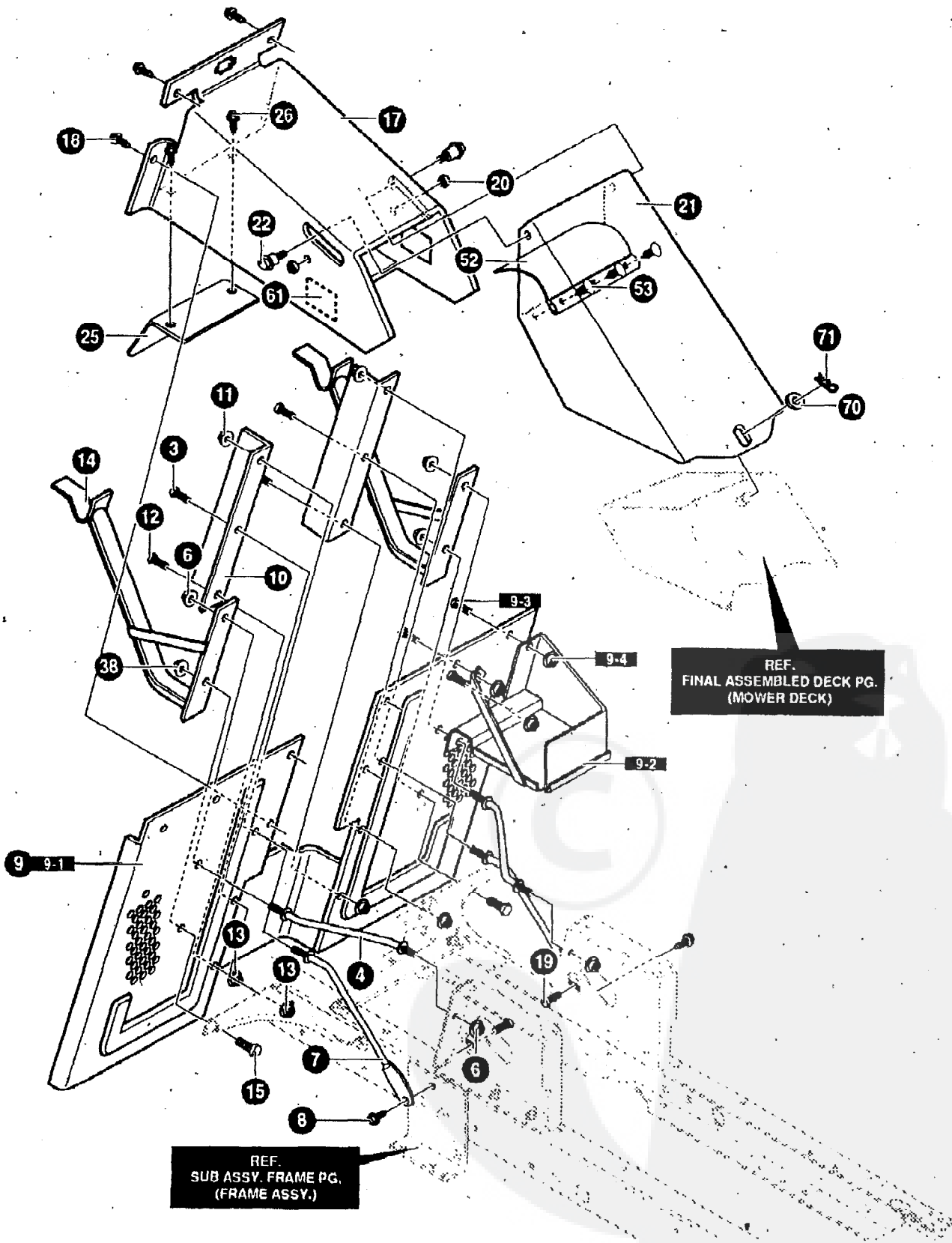

NOTE: ALWAYS USE ORIGINAL EQUIPMENT PARTS.
Use of service/replacement parts other than original equipment parts may void your warranty.

ALL UNNUMBERED
ITEMS ARE INTERCHANGEABLE
WITH OPPOSITE SIDE

340926C

KEY NO.	PART NO.	DESCRIPTION	QTY
3	710079	SCREW, 5/16-18X.75	2
4	94625	ROD, BRACE	2
6	45171	NUT, 3/8-16 HWDFL WHIZ-LOCK	4
7	9423 1	ROD, BRACE	2
8	710079	SCREW, 5/16-18X.75HHWATAP	2
9	341493-853	BACK PLATE/BATTERY ASSEMBLY	1
9-1	94569	BACK PLATE ASSEMBLY	1
9-2	94563	BATTERY TRAY WELD ASM.	1
9-3	180073	SCREW, 5/16-18X SO HHG	3
9-4	45174	NUT, 5/16-18 HEXWDFLLK WHIZ	3
10	94232-853	GRACE, BACK PLATE	2
11	45171	NUT, 3/8-16 HWDFL WHIZ-LOCK	2
12	328154	SCREW, 5/16-18X1 .OWDFLLK	4
13	45174	NUT, 5/16-18 HEXWDFLLK WHIZ	4
14	94637-853	ASSY, COLLECTOR SUPPORT	2
15	328154	SCREW, 5/16-18X1 .OWDFLLK	2
17	94295-853	CHUTE WELD ASM. UPPER	1
18	710079	SCREW, 5/16-18X.75HHWATAP	4
19	57101	BOLT, 5/16-18X.75 CARR	2
20	45174	NUT, 5/16-18 HEXWDFLLK WHIZ	2
21	94970-853	CHUTE MIDDLE ASSY	1
22	51601	BOLT, .500X.453 HHSH 3/8-16	2
25	94263-853	COVER,, T-AXLE SHIELD	1
26	710264	SCREW, 1/4-20X.50 WAHHTAP	2
52	94264	FLAP,CHUTE REBA	1
53	309235	RATCHET FASTENER	3
61	318197	PAD, "ADHESIVE 1.00X1.50X12	2
70	710116	WASHER, FLAT .281X.63X.065	1
71	710343	PIN, HAIR .38DIA X1.64LG	1

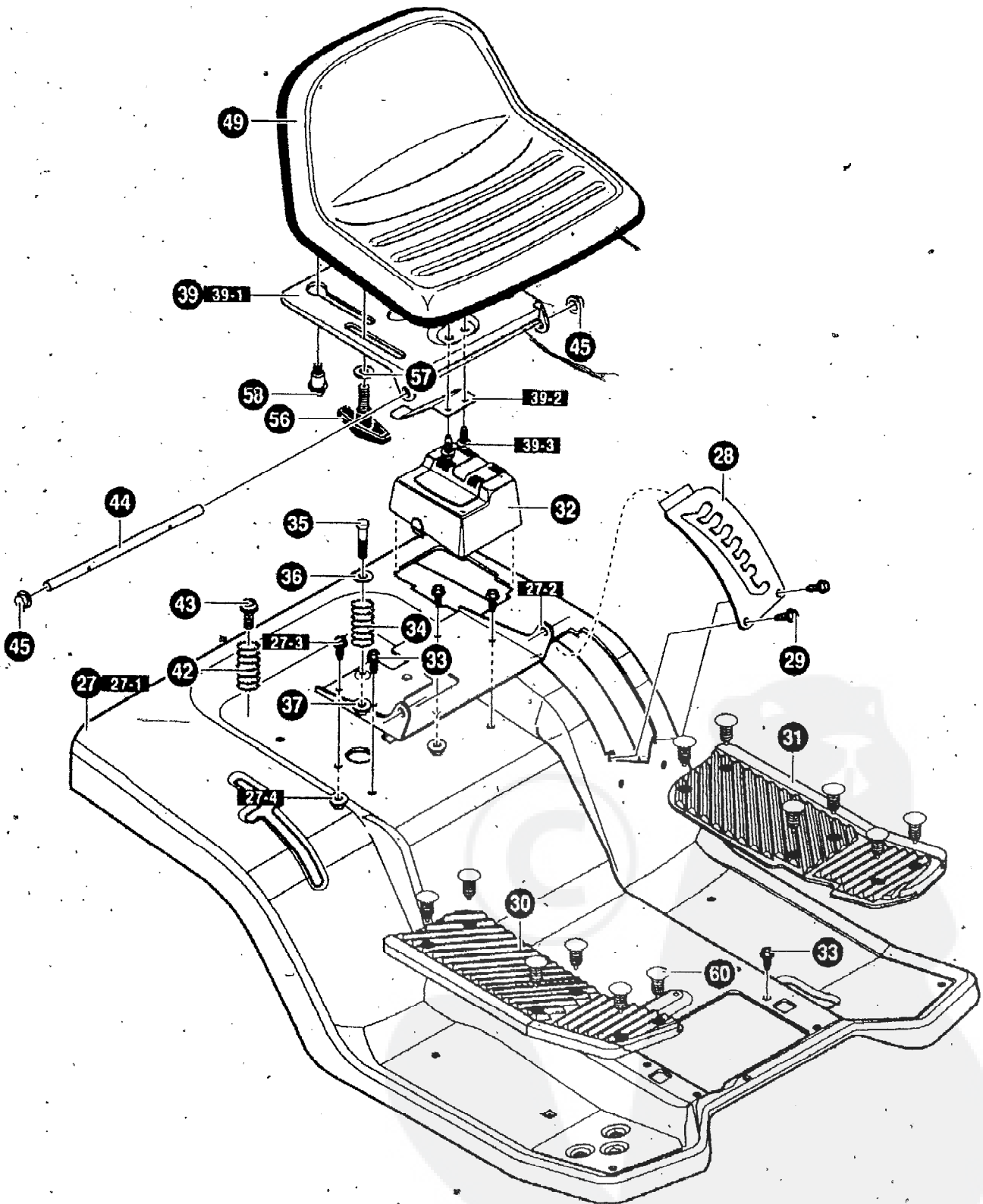

NOTE: ALWAYS USE ORIGINAL EQUIPMENT PARTS.
 Use of service/replacement parts other than original
 equipment parts. may void your warranty.

ALL UNNUMBERED
 ITEMS ARE INTERCHANGEABLE
 WITH OPPOSITE SIDE

340926C

KEY NO.	PART NO.	DESCRIPTION	QTY
27	341496 -836	ASM.SEAT DECK PEDAL GEAR REBA	1
2 7 - 1	94204	SEAT DECK,GEAR DRIVE	1
27-2	94153	BRACKET, PIVOT SEAT	1
27-3	7 10279	SCREW, 5/16-18X.625	2
27-4	710205	NUT, 5/16-18 WDFLLK(15X88)	2
28	94243-836	PLATE, LIFT DETENT	1
29	710196	SCREW, 10-24X.500TRSEGI	2
30	95409	FOOTREST PAD RH	1
31	95408	FOOTREST PAD L H	1
32	94200	COVER, BATTERY	1
33	710079	SCREW, 5/16-18X.75HHWATAP	3
34	710136	SPRING, COMPRESS 4.57LG X 1.17	1
35	710093	BOLT,SHOULDER 1/4-20NC-2A(9X55)	1
36	94155	WASHER CUP ZINC	1
37	710280	NUT, 1/4-20 WDFLLK (15X89)	1
39	341494-836	ASSY. SEAT SUPPORT	1
39-1	94154	SUPPORT, SEAT	1
39-2	94057	SPRING - LEAF	1
39-3	710264	SCREW, 1/4-20X.50 WAHHTAP	2
42	710109	SPRINGCOMPRESS 2.43LG(164X30)	2
43	710079	SCREW, 5/16-18X.75HHWATAP	2
44	94156	ZINC HINGE SEAT PIVOT	1
45	710192	NUT, PUSH CAP .375 (28X23)	2
49	95415	SEAT, QK ADJUST	1
56	94160	BOLT, WING 5/16-18	2
57	710281	WASHER, FLAT.344X.62X.06	2
58	710101	BOLT, SHOULDER 5/16-18NC (9X56)	2
6 0	309235	FASTENER,RATCHET	12

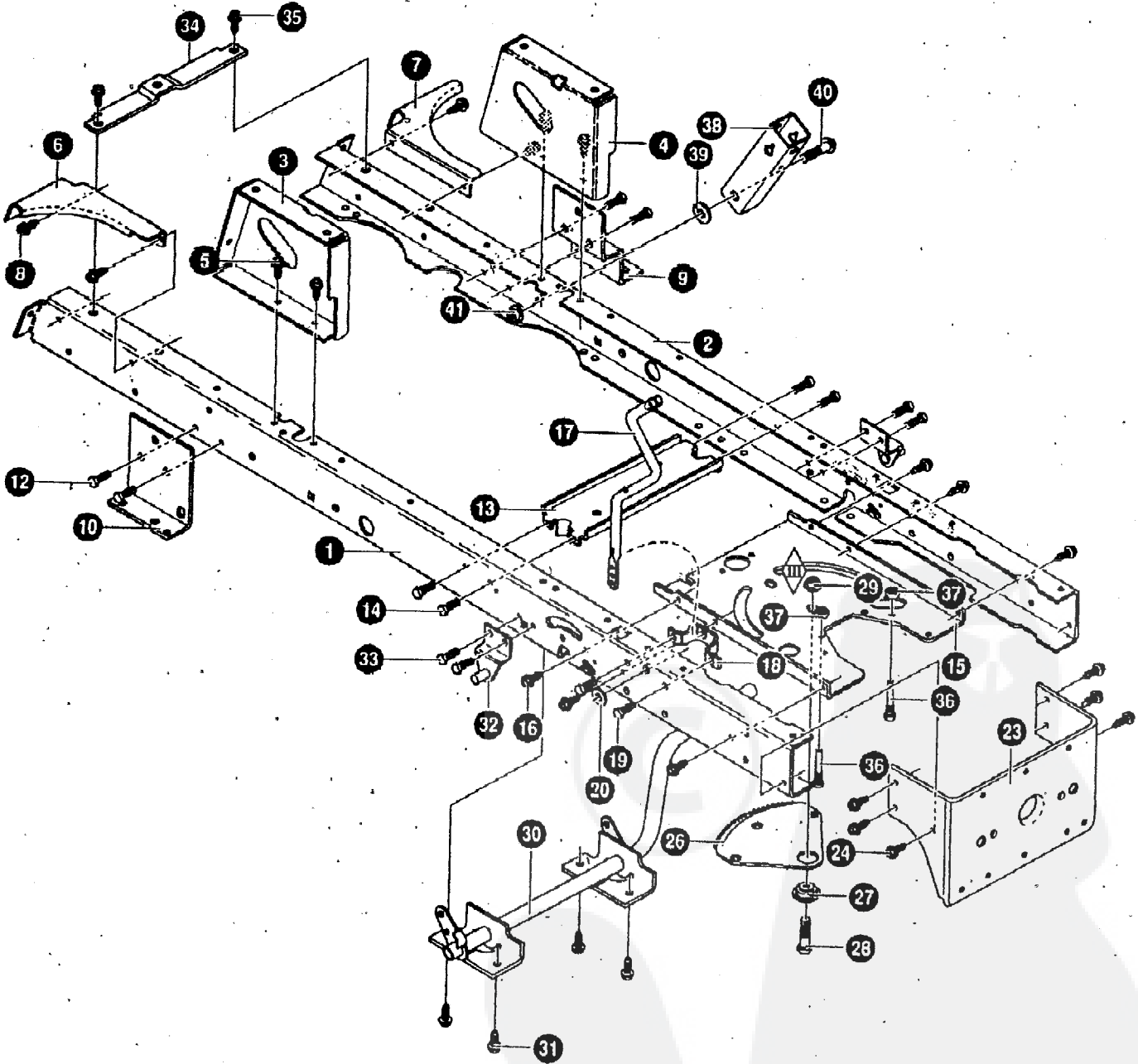

NOTE: ALWAYS USE ORIGINAL EQUIPMENT PARTS.
Use of service/replacement parts other than original
equipment parts may void your warranty.

ALL UNNUMBERED
ITEMS ARE INTERCHANGEABLE
WITH OPPOSITE SIDE

340413A

KEY PART NO.	PART NO.	DESCRIPTION	QTY
1	94564	FRAME,RAIL RH	1
2	94565	FRAME,RAIL LH	1
3	94634	SUPPORT,SEAT R H	1
4	94633	SUPPORT,SEAT LH	1
5	710079	SCREW; 5/16-18X.75HHWATAP	4
6	94561	BRACE, BACKPLATE RH	1
7	94562	BRACE, BACKPLATE LH	1
8	710079	SCREW, 5/16-18X.75HHWATAP	4
9	94234	BRACKET,T/A RH-VST,LH-MST	1
10	94235	BRACKET,TRANSAXLE RH-MST	1
12	710079	SCREW, 5/16-18X.75HHWATAP	4
13	94237	ASM. IDLER MOUNT,FRONT	1
14	710079	SCREW, 5/16-18X.75HHWATAP	4
15	94003	PLATE,STEERING MOUNTING	1
16	710079	SCREW, 5/16-18X.75HHWATAP	6
17	94019	CRANK, PTO (DRILLED)	1
18	94005	BRACKET, BELL CRANK	1
19	710079	SCREW, 5/16-18X.75HHWATAP	2
20	120395	WASHER, FLAT .469X .92X.065	1
23	94013	BRACKET, HANGER REAR	1
24	710079	SCREW, 5/16-18X.75HHWATAP	6
26	94121	GEAR, SECTOR	1
27	94123	BEARING, SECTOR GEAR	1
28	710312	SCREW, 5/16-18X1.00	1
29	710105	NUT, 5/16-18 HWDFLLK (15X113)	1
30	94241	ASM.CLUTCH/BRAKE PEDAL	1
31	710079	SCREW, 5/16-18X.75HHWATAP	4
32	94285	BRACKET SUPENSION ASM.	2
33	710079	SCREW, 5/16-18X.75HHWATAP	4
34	94566	BRACE, RAIL	1
35	710079	SCREW, 5/16-18X.75HHWATAP	2
36	93349	SCREW GUIDE 5/16-18	2
37	710204	NUT,5/16-18 HEXWDFLLK WHIZ PL	2
38	94015	BRACKET, PIVOT	1
39	845	WASHER, FLAT .390X1.25X.119	1
40	710000	BOLT, .562X1.563 HSH 3/8-16	1
41	710140	NUT,3/8-16HWDFLLK MACK (15X84)	1

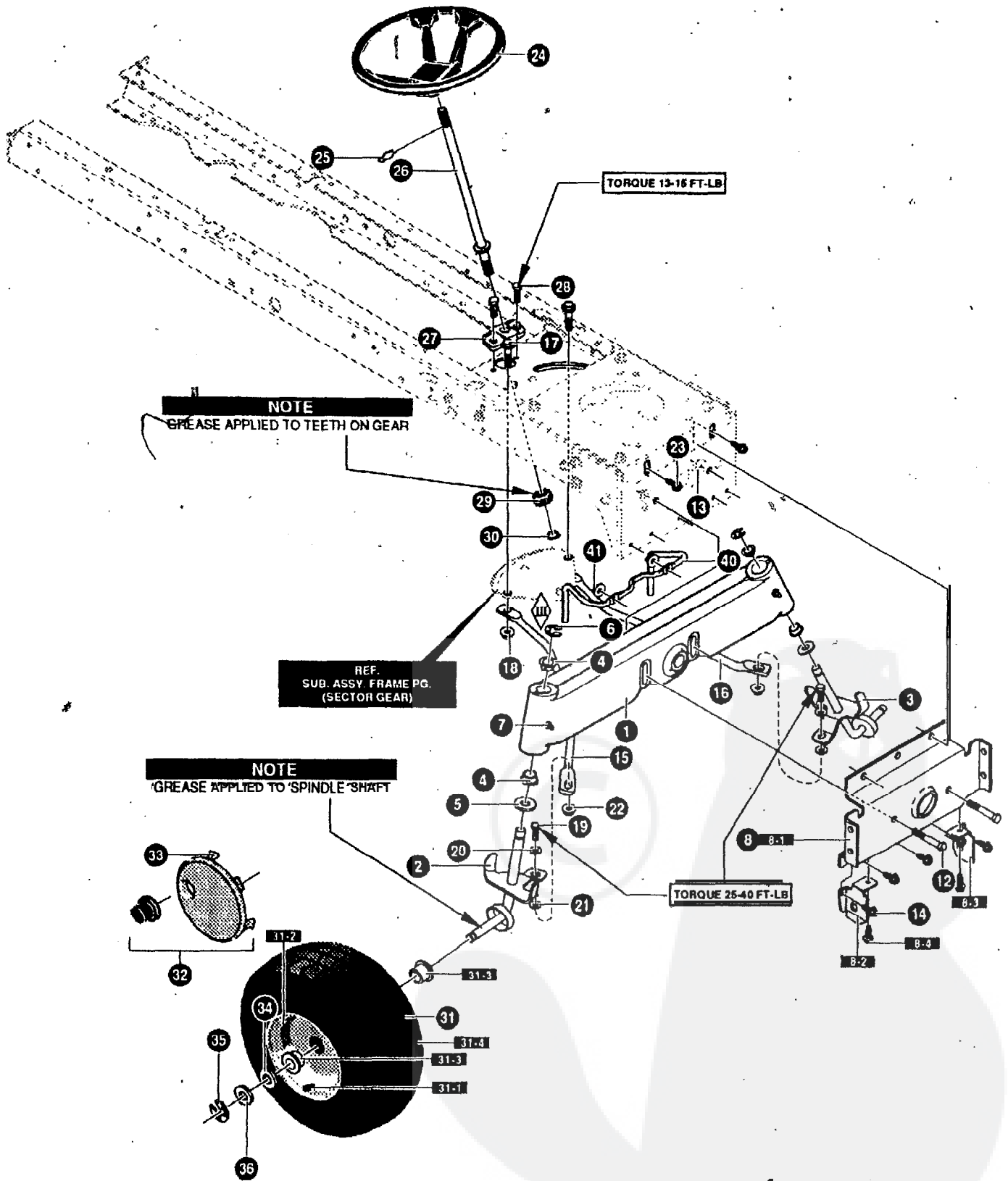

NOTE: ALWAYS USE ORIGINAL EQUIPMENT PARTS. Use of service/replacement parts other than original equipment parts may void your warranty.

ALL UNNUMBERED ITEMS ARE INTERCHANGEABLE WITH OPPOSITE SIDE

340597A

KEY NO.	PART NO.	DESCRIPTION	QTY
1	95405-853	AXLE, CAST MACHINED	1
2	94178-853	SPINDLE,RH MO#94178	1
3	94179-853	SPINDLE LH,WELD ASSEMBLY	1
4	92527	BEARING, SPINDLE	4
5	710129	WASHER,.766 ID X 1.6210 16GA	2
6	710103	E-RING .574IDX.050/.750SH 11 X3	2
7	706	ZERK, GREASE FITTING	2
8	341491-853	ASM.FRONT AXLE/DECK HANGER	1
8-1	9 4 0 0 7	HANGER, AXLE	1
8-2	94290	HANGER,DECK RH	1
8-3	94289	HANGER,DECK LH	1
8-4	710079	SCREW, 5/16-18X.75HHWATAPSGIBP	2
12	180113	SCREW, 5/16-18X3.00	2
13	710205	NUT, 5/16-18 WDFLLK (15X88) Z	2
14	710079	SCREW, 5/16-18X.75HHWATAPSGIBP	2
15	94020-853	DRAG LINK RH	1
16	94021-853	DRAGLINK, L H	1
17	710440	BOLT,HSSH (9X57)	2
18	710140	NUT,3/8-16HWDFLLK MACK 15X84	2
19	710082	SCREW, 3/8-16X1.5	2
20	710083	WASHER, FLAT .391X1.00X.083	2
21	710142	WASHER, FLAT.406X.81 XI 6GA	2
22	710140	NUT,3/8-16HWDFLLK MACK 15X84 Z	2
23	710079	SCREW, 5/16-18X.75HHWATAPSGIBP	3
24	95441	STEERING WHEEL	1
26	94127	SHAFT, STEERING	1
27	94124	BEARING-LOWER	1
28	710079	SCREW, 5/16-18X.75HHWATAPSGIBP	2
29	94122	GEAR PINNION	1
30	710102	RING, RET E.54ID.59SH(11X25)	1
31	692287	TIRE & RIM	2
31-1	338512	VALVE STEM	2
31-2	338517	RIM, CARLISLE.	2
31-3	338513	BEARING	2
31-4	338516	TIRE, 15X6X6	2
34	710131	WASHER, FLAT .759ID (340435)	2
35	36625	RETAINING RING	2
36	710350	WASHER, FLAT .765X1.62X.065Z	2
40	94310	GUIDE-STACK PULLEY BELT	1
41	45174	NUT, 5/16-18 HEXWDFLLK WHIZ	2

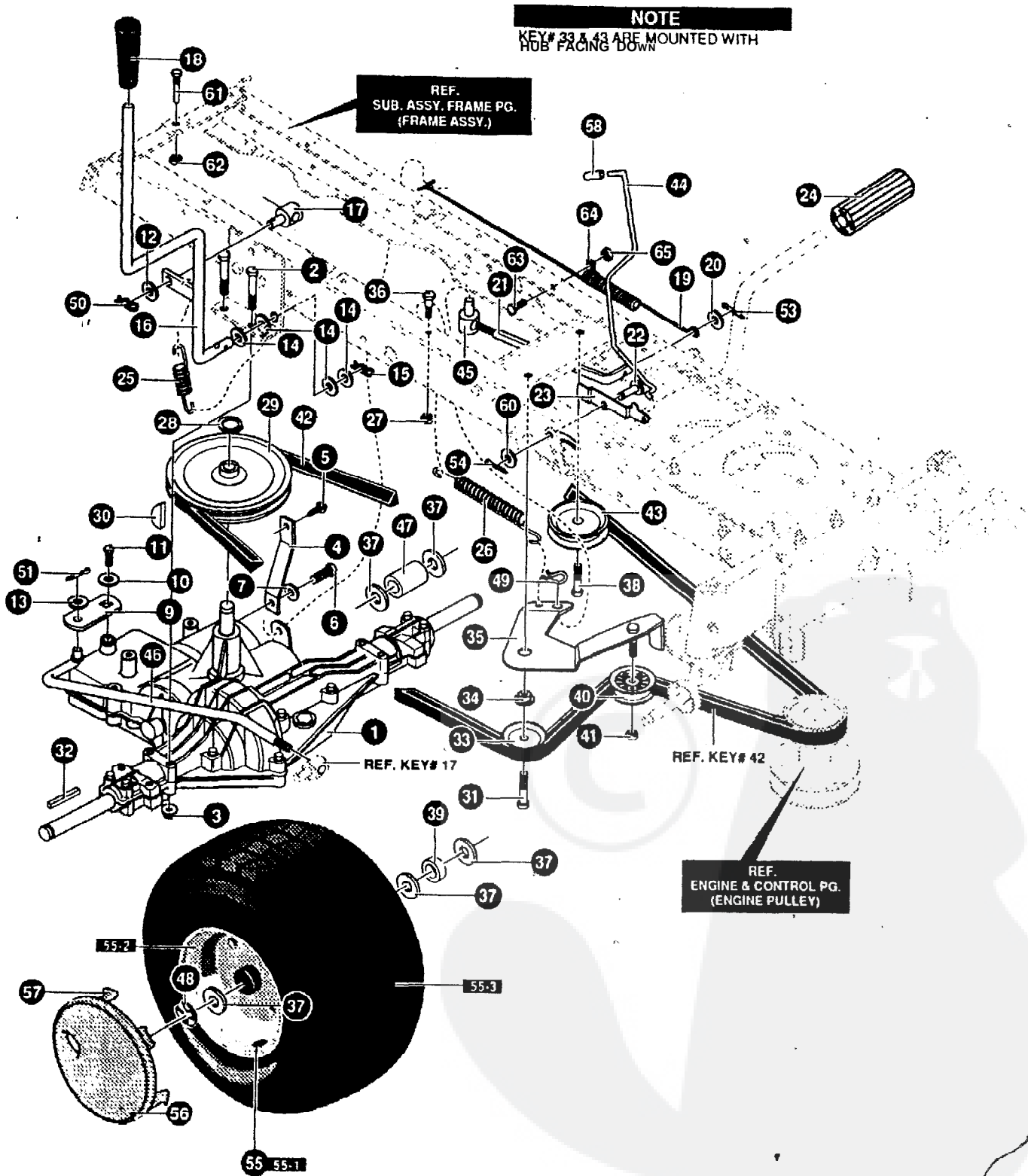

NOTE; ALWAYS USE ORIGINAL EQUIPMENT PARTS. Use of service/replacement parts other than original equipment parts *may void your warranty.*

ALL UNNUMBERED ITEMS ARE INTERCHANGEABLE WITH OPPOSITE SIDE

KEY NO.	PART NO.	DESCRIPTION	QTY
2	180091	TRANSAXLE, MST206-512A, 5/16-18X2.50. SCREW,	41
3			
4	94620-853 710205	BRACKET, STABILIZER (15X88)	41
5	710079	SCREW, 5/16-18X.75 HHWATAP	1
6	35498	SCREW, 5/16-18X.75 WAHHTAP	1
7	120638	WASHER, HVSPTLK .328X.60X.09	1
9	94227	BRKT, SHIFT REBA FENDER HT	1
10	57157	WASHER, .750X.250 SP-TRANSAXLE	1
11	56255	SCREW, 1/4-28X.75 NYL	1
12	996416	WASHER, FLAT .391X 1.00X.125	1
14	120394	WASHER, FLAT .406X .81X.065	1
15	996425	WASHER, FLAT .515X.88X.064	4
	56180	PIN, HAIR .53DIAX1.62LG	1
17	94242	SHIFT LEVER, MST GEAR DRIVE	1
18	21920	NUT, ADJ. 3/8-16TAP	1
	92697	GRIP, BLACK VINYL, HEIGHT ADJ	1
20	38274 9424	SPRING, BRAKE FLAT .328X1.06X.062 35.00	1
		WASHER,	1
22			1
23	99533 94045	ROD, CLEVIS .375DX.81 LG	1
		LATCH, PARK BRAKE	1
25	21544	PEDAL, BRAKE/CLUTCH STD NLT	1
26	35410 710139	SPRING, .071TENS X .62 .09X. X 4.37 X5.	11
		SPRING,	1
27	780029	1/4-20 HEX NYLOCK NUT #71035	1
28	22053	RING, RETEX .58X.035TRU5100-62	1
29			1
30	99575 99606	REIN, PROOF .64X.75DIAX.187WD	1
31	710082	SCREW, 3/8-16X1.5 HHCFLTHR5	1
32			1
34	35374 52928	KEY, PULLEY, SQUARE IDLER .187SQX2.25LG V4L 3.06X .62	21
35	95423	SPACER, SHOULDER	1
	94238-853	ASSY, IDLER ARM TRACTION	1
36	310088	BOLT, .250X.312 HSH 1/4-20	1
38	710131	WASHER, FLAT .775ID	1
39	95418 180124	SCREW, SPACER, 3/8-1.87 X 6X1.25 1.25 WHEEL	2
			1
42	95975	NUT, 3/8-16 HWDFLLK MACK	1
43	35374 94608	BELT, PULLEY, V 4L IDLER 114.12 V4L 3.06X .62	1
			1
44	94566	PARK BRAKE CONTROL ROD	1
45	710059	NUT, 5/16-18X3/8 ADJUSTING	1
46	94570	ROD, SHIFT LINK	1
47	95419	SPACER, .87 X 2.25 WHEEL	1
48	36625	RING, RETEX .57X.05TRU5133-75	2
49	56180	PIN, HAIR .53DIAX1.62LG	1
50	340470	PIN, HAIR .38DIAX1.64+LG	1
51	121222	PIN, COTTER .090DIAX.75LG	1
53			11
54	121222 121222	PIN, PIN, COTTER COTTER .090.090DIAXDIAX.75LG.75LG	11
55	692289	TIRE & RIM	2
55-1	336512	VALVE STEM	1
55-2	338524	RIM	1
55-3	338549	TIRE 18X8.5X8	1
60	335980	CAP, DUMP VALVE ROO.25IDX.75	1
61	20619 120394	WASHER, SCREW GUIDE FLAT 5/16-18 .406X.81X.065	11
63	710204	NUT, 5/16-18 HEXWDFLLK WHIZ	1
64	57569 180016	SCREW, RETAINER, 1/4-20X.50 WIRE	1
			1
65	51335	NUT, 1/4-20 WHIZ-LOCK	1

. CONTACT YOUR NEAREST TRANSAXLE DEALER FOR PARTS AND SERVICE.

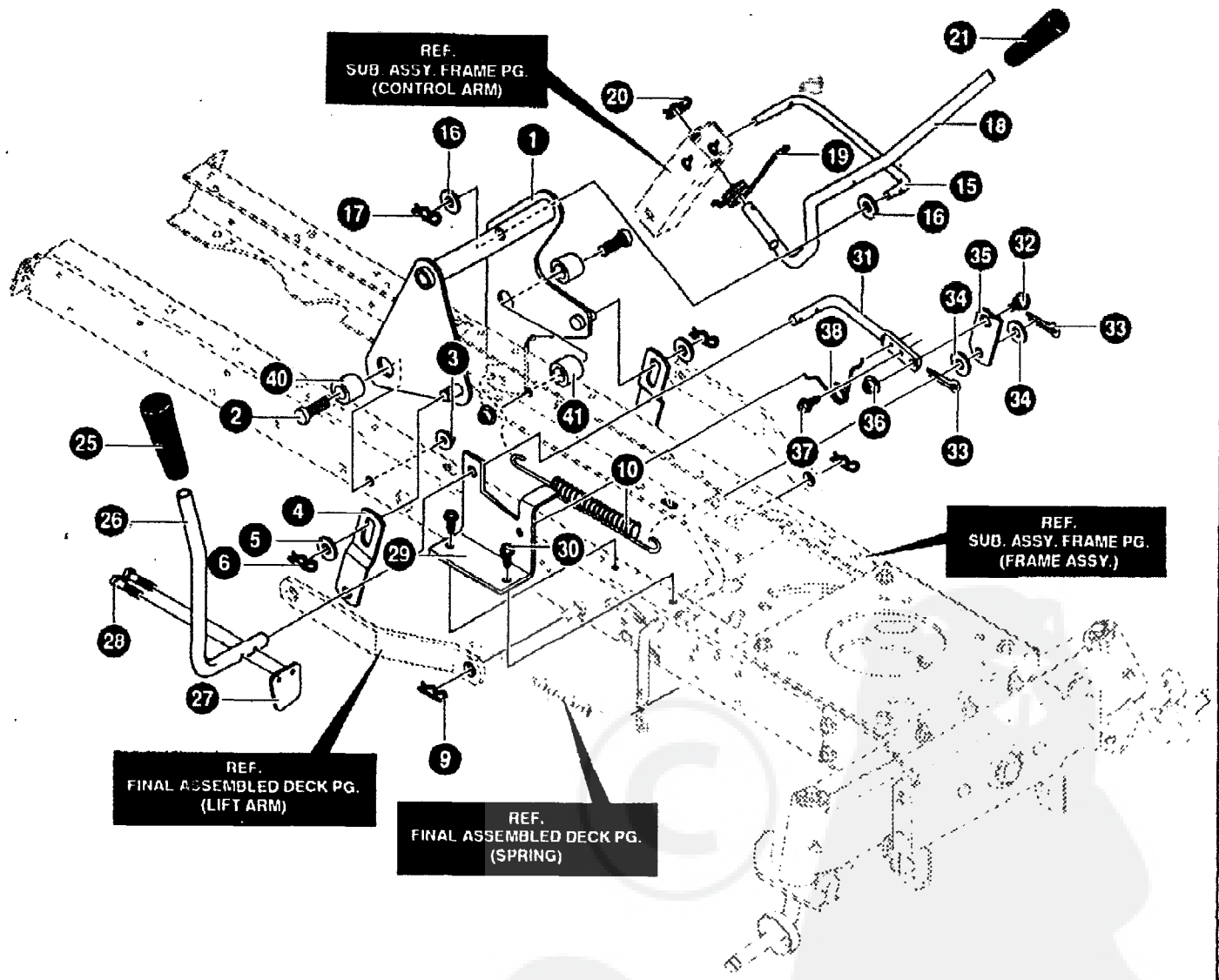

NOTE: ALWAYS USE ORIGINAL EQUIPMENT PARTS.
Use of service/replacement parts other than original
equipment parts may void your warranty.

ALL UNNUMBERED
ITEMS ARE INTERCHANGEABLE
WITH OPPOSITE SIDE

34089C

KEY NO.	PART NO.	DESCRIPTION	QTY
1	94299-853	LIFT ARM WELD ASSEMBLY	1
2	710222	SCREW, 1/2-13X1.50 (1X127)	2
3	710223	NUT, 1/2-13 LOCK (15X41)	2
4	94262-853.	BRACKET, LIFT LINK	2
5	710119	FLATWASHER (17X91)	2
6	710108	PIN, HAIR (31X4)	2
9	710108	PIN, HAIR (31X4)	2
10	710235	SPRING, EXTENSION 9.82X1.010D	1
15	94276	LINK, LIFT HANDLE	1
16	710119	FLATWASHER (17X91)	2
17	8260	PIN, HAIR .091 DIA X1.66LG	1
18	94029	HANDLE, LIFT	1
19	710111	TORSION SPRING .657LG(166X40)	1
20	710108	PIN, HAIR (31 X4)	1
21	92697	GRIP, BLACK	1
25	92698	GRIP, BLACK	1
26	94826	PTO LEVER	1
27	94022	PADDLE, SWITCH	1
28	71'0137	SCREW, THD FORMING	2
29	94018-853	BRACKET, PTO	1
30	710079	SCREW, 5/16-18X.75HHWATAP	2
31	94017	LEVER, PTO	1
32	710098	BOLT.50X.75 HSH 3/8-162 9X39	1
33	36366	HAIR PIN	2
34	710115	FLATWASHER .518X.87X1617X102	2
35	94004	LINK PTO ZINC	1
36	710140	NUT, 3/8-16HWDFLLK MACK (15X84)	1
37	710079	SCREW, 5/16-18X.75HHWATAP	1
38	710141	TORSION SPRING .33LG(166X39)	1
40	94389	SPACER.513 ID X .880 OD	2
41	56150	SPACER, SLEV .94X1.13X.531	1

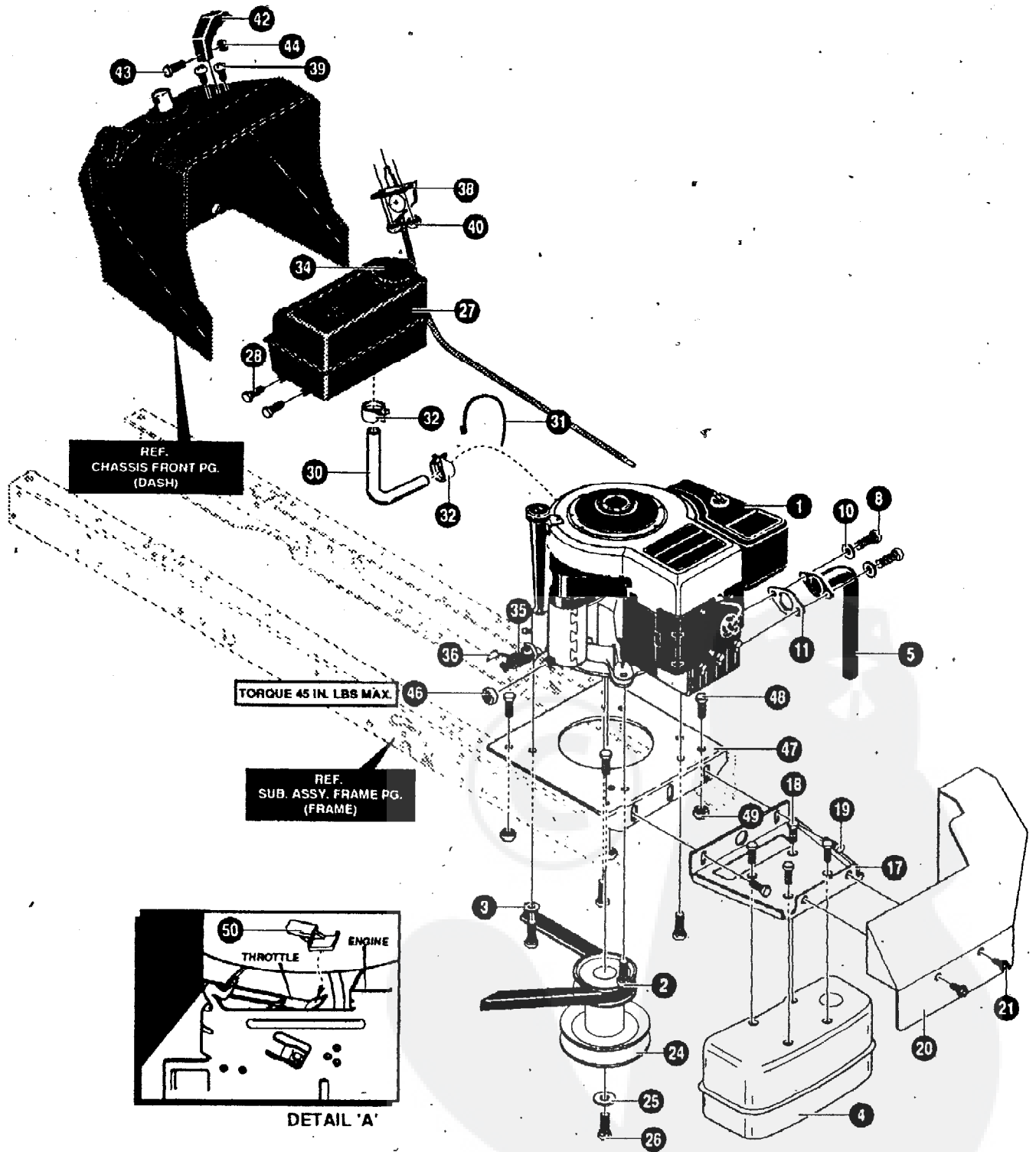

NOTE: ALWAYS USE ORIGINAL EQUIPMENT PARTS. Use of service/replacement parts other than original equipment parts may void your warranty.

ALL UNNUMBERED ITEMS ARE INTERCHANGEABLE WITH OPPOSITE SIDE

KEY NO.	PART NO.	DESCRIPTION	QTY
1	(289707-0121-01) ENGINE	12.5HPBS IC DC (SEE ENGINE MANUAL)	1
2	50947	SCREW, 3/8-16X1.25	4
3	138489	WASHER, EXLK .384X.69X.04	1
4	94902	MUFFLER, SUPER LOW TONE 12.5	1
5	94900	EXHAUST PIPE 12.5 B&S	1
a	180077	SCREW, 5/16-18X.75 HHC	2
10	120638	WASHER, HVSPTLK .328X.60X.09	2
11	46708	GASKET, MUFFLER	1
17	94901-853	BRACKET MUFFLER 12.5HP	1
1a	44811	SCREW, 1/4-20X.75	4
20	94904-853	HEAT SHIELD WELD ASSY.	1
21	710079	SCREW, 5/16-18X.75HHWATAPSGIBP.	2
24	94308	PULLEY, ENGINE 4.89X6.75X5.4OFF	1
25	120383	WASHER, REGSPTLK.459X.78X.12	1
26	433146	SCREW, 706-20X4.25	1
27	309853	TANK; FUEL 1.5 WO/SENSOR CLEAR	1
30	710246	SCREW, 15TPIX. PANHTAP	4
31	501 57444 18	TUBING, .25X.50X BULK GAS LINE	12"
		TIE, CABLE BLACK	1
32	47345	CLAMP, HOSE SCREW	1
34	12501	CAP, FUEL 2.5" THROAT	1
35	325547	OIL DRAIN VALVE ASSEMBLY	1
36	327422	CAP, OIL DRAIN VALVE	1
39	94906	THROTTLE CONTROL	1
40	308459 155941	SCREW, 10-24X.63	2
		NUT, #10-24	2
42	300508	KNOB, THROTTLE CONTROL	1
43	159585	SCREW, #8-32X.38 PHPNMA	1
44	120622	NUT, #a-32 REGHX	1
46	124818	NUT, 1/4-20 REGHXJAM	1
47	94006-853	PLATE, ENGINE	1
49	710079	SCREW, 5/16-18X.75	4
50	94894 710205	NUT, 5/16-18 WDFLLK (15X88)	4
		CLIP, SPEED	1

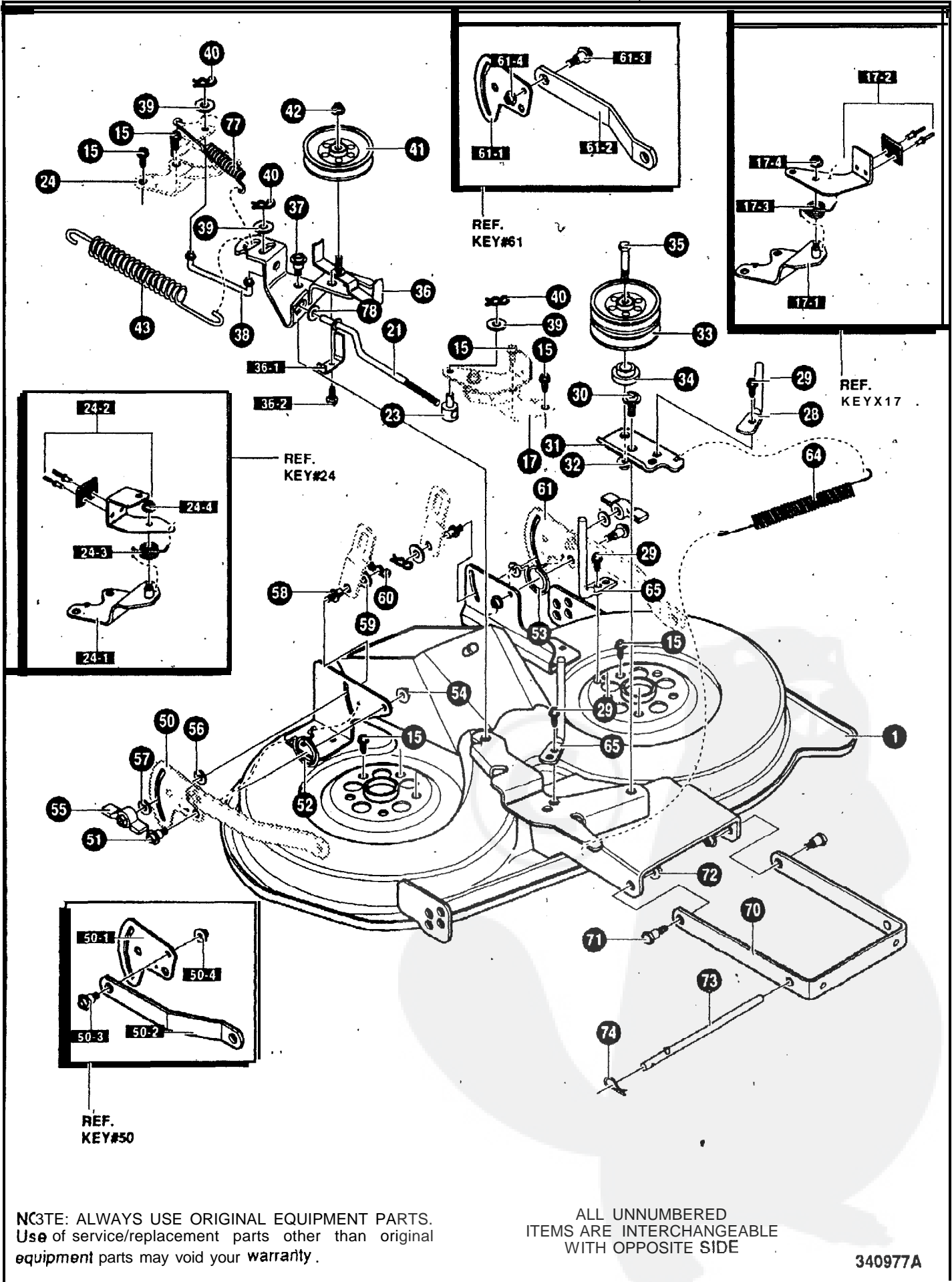

NOTE: ALWAYS USE ORIGINAL EQUIPMENT PARTS. Use of service/replacement parts other than original equipment parts may void your warranty.

ALL UNNUMBERED ITEMS ARE INTERCHANGEABLE WITH OPPOSITE SIDE

340977A

KEY NO.	PART NO.	DESCRIPTION	QTY
1	94303 -853	WELD ASSEMBLY DECK	1
15	710265	SCREW, 3/8-16X1.00 WAHHSPTAPPL	10
17	94665-853	BRAKE ARM ASSEMBLY LH	1
17-1	94293	BRAKE SUPPORT ASSEMBLY LH	1
17-2	94291	BRAKE ARM ASSEMBLY LH	1
17-3	710110	SPRING, TORSION (166X27)	1
17-4	710205	NUT, 5/16-18 WDFLLK (15X88)	1
21	94277	LINK, BRAKE LH	1
23	21920	NUT, ADJ. 3/8-16TAP	1
24	94664-853	BRAKE ARM ASSEMBLY RH	1
24-1	9 4 2 9 4	BRAKE SUPPORT ASSEMBLY RH	1
24-2	94292	BRAKE ARM ASSEMBLY RH	1
24-3	710077	SPRING, TORSION	1
24-4	710205	NUT, 5/16-18 WDFLLK (15X88)	1
28	94274	GUIDE, BELT REBA	1
29	710114	SCREW, 5/16-18 .50HHTAP	3
30	710098	BOLT, 50X.75 HSH 3/8-16Z 9X39	1
31	94261-853	ARM, DOUBLE IDLER	1
32	710140	NUT, 3/8-16HWDFLLK MACK 15X84	1
33	94279	PULLEY, IDLER DOUBLE VEE	1
34	94269	SPACER, REBA DECK	1
35	180138	SCREW, 3/8-16X3.00 HHC	1
3 6	94973-853	IDLER ARM ASSEMBLY	1
36-1	94312	SPRING, GUIDE BELT	1
36-2	7 1 0 2 6 4	SCREW, 1/4-20X.50 WAHHTAP	1
37	710098	BOCT. 50X.75 HSH 3/8-16Z 9X39	1
38	94278	LINK, BRAKE RH	1
39	316079	WASHER, FIAT .406X .82X.040	1
4 0	710343	PIN, HAIR .38 DIAX1.64LG	3
41	94280	PULLEY, V IDLER 4"	1
42	710140	NUT, 3/8-16HWDFLLK MACK 15X84	1
43	710234	SPRING, EXTN 5.40X.71400	1
50	341593-853	PLATE - SUSPENSION ASSY	1
50-1	94128	PLATE - SUSPENSION	1
50-2	94055	SUSPENSION BRKT REAR	1
50-3	710095	SHOULDER BOLT 3/8-16 (9X52)	1
50-4	710140	NUT, 3/8-16 MACK (15X84)	1
51	710094	BOLT, SHOULDER .375 (9X51)	2
52	710112	SPRING, TORSION .68LG RH (166X42)	1
53	710113	SPRING, TORSION .68LGLH (166X43)	1
54	710140	NUT, 3/8-16HWDFLLK MACK (15X84)	2
55	94068	KNOB	2
56	94137	PAD, FRICTION	2
57	710195	WASHER (17X45)	2
58	94064	PIN, HANGER	2
59	710116	WASHER, FLAT. 550X1.00X11 (17X103)	2
60	710100	PIN, HAIR (31X4)	2
61	341594-853	ASM. PLATE REAR SUS BRKT LH	1
61-1	94128	PLATE - SUSPENSION	1
61-2	94055	SUSPENSION BRKT REAR	1
61-3	710095	SHOULDER BOLT 3/8-16 (9X52)	1
61-4	710140	NUT, 3/8-16 MACK (15X84)	1
64	710233	SPRING, EXTN 4.20X.750D	1
65	94275	GUIDE BELT	2
70	94058-853	BRACKET, FRT SUSPENSION	1
71	710094	BOLT, SHOULDER .375 (9X51)	2
72	710140	NUT, 3/8-16HWDFLLK MACK (15X84)	2
73	94158	ZINC ROD, HANGER	1
74	710108	PIN, HAIR (31X4)	1
77	710658	SPRING, EXTENSION	1
78	996416	WASHER, FLAT .391 XI.00X.125	1

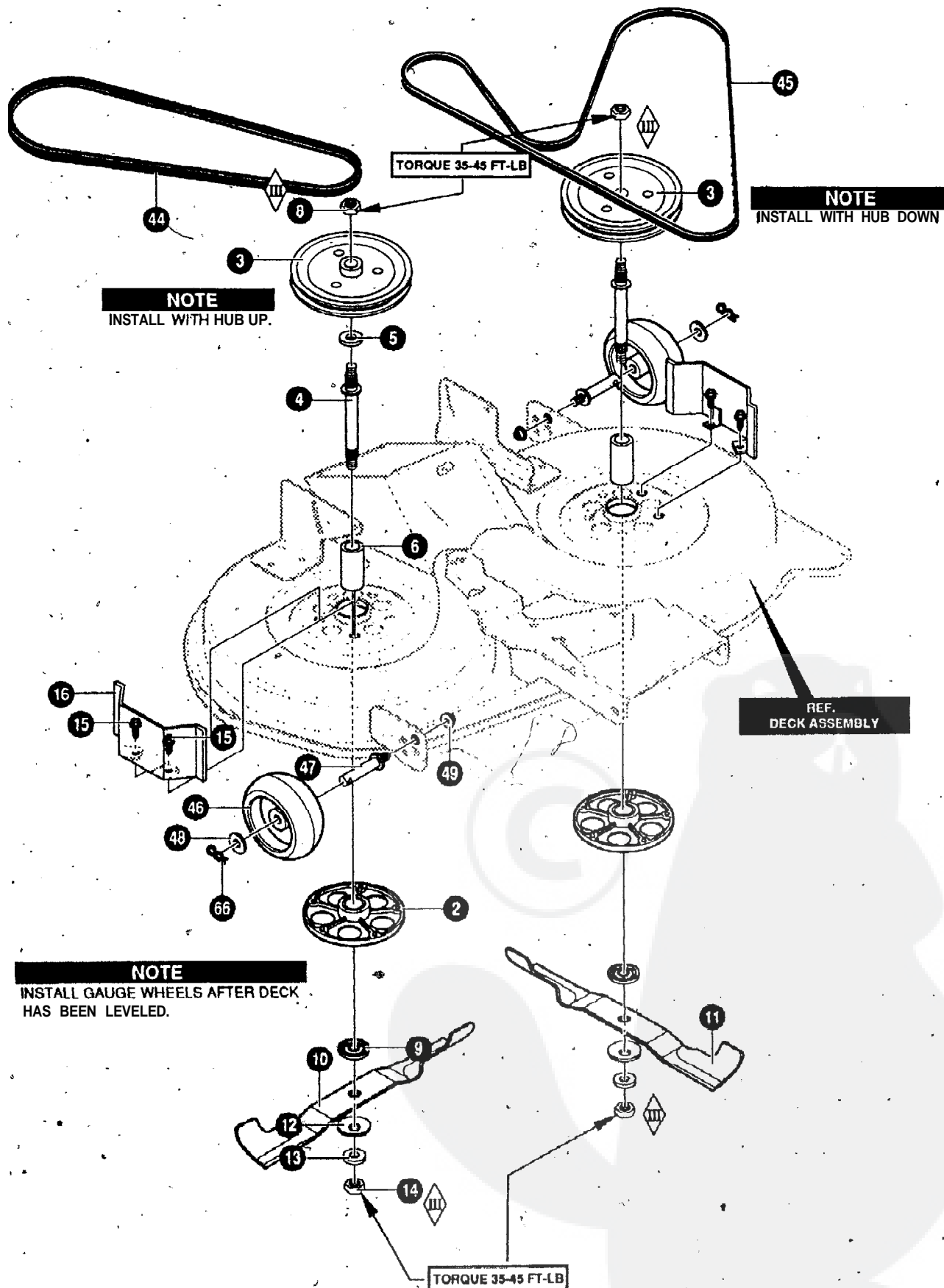

NOTE: ALWAYS USE ORIGINAL EQUIPMENT PARTS. Use of service/replacement parts other than original equipment parts may void your warranty.

ALL UNNUMBERED ITEMS ARE INTERCHANGEABLE WITH OPPOSITE SIDE

KEY NO.	PART NO.	DESCRIPTION	QTY
2	94305	ASM.JACKSHAFT HOUSING W/VENTS	2
3	9 2 4 2 5	PULLEY, DECK REBA	2
4	91922	JACKSHAFT, 7.76LG-9/16-18TH	2
5	7.10117	WASHER,FLAT .625X1.00X. 188	1
6	91903	SPACER	2'
8	710408	NUT, 9/16-18 CTLK (15X101)	2
9	94207	ADAPTER, DECK/BLADE	2
10	94208	BLADE, 40" RH REAR DISCHARGE	1
11	94209	BLADE, 40" LH REAR DISCHARGE	1
12	710118	WASHER, FLAT.625X1.75 17X166	2
13	710117	WASHER,FLAT .625X1.00X. 188	2
14	710408	NUT, 9/16-18 CTRLK 15X101	2
15	710265	SCREW, 3/8-16X1.00 WAHHSPTAPPL	10
16	94288-853	COVER PULLEY	2
44	710231	BELT, V	1
45	710232	BELT, V- 40" DECK	1
46	92683	GAUGE WHEEL,4.94 DIA.	2
47	94025	BOLT, SPSH 3/8-16X.63SH3.00LG	2
48	710115	WASH ER,FLAT.518X.87X16 17X1 02	2
49	710140	NUT,3/8-16HWDFLK MAÇK 15X84	2
66	710108	HAIR PIN (31X4)	2

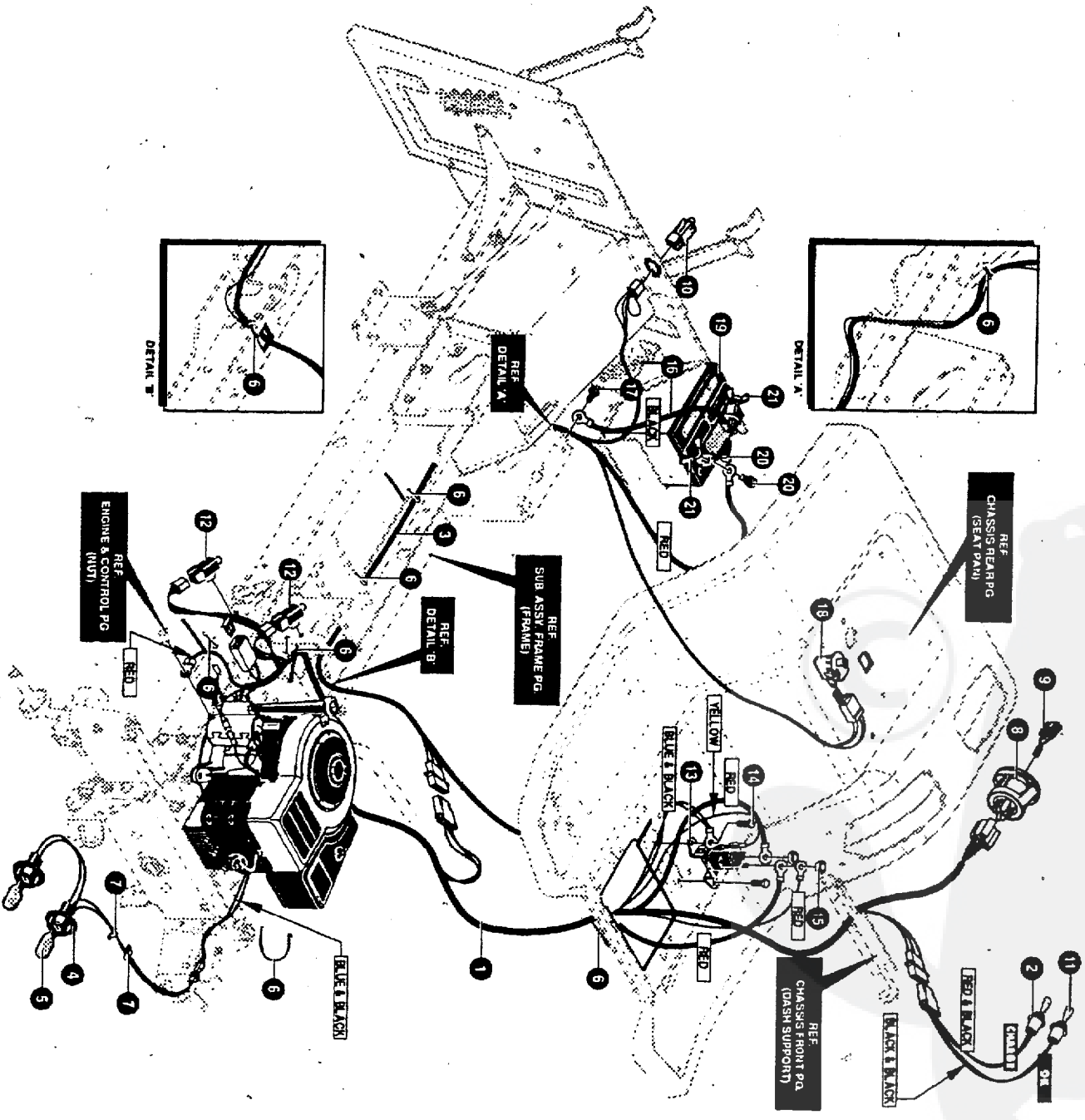

KEY NO.	PART NO:	DESCRIPTION	QTY
2	94740 94751	HARNESS 12.5B&S	1
		HARNESS ADAPTER,OK/CHARGE IL	1
3	94742	HARNESS, REAR-BATTERY	1
4	303064	ASSY,LIGHT WIRE-1/4 TURN	1
5	52572	BULB, HEADLAMP	2
6	57444	TIE, CABLE BLACK NYLON	5
7	41482	PRESS CLIP,1.380LG.255ID	2
8	94762	SWITCH, IGNITION D	1
9	327350	KEY,IGNITION	2
10	320082	SWITCH,DOUBLE POLE	1
11	57769	BULB, INDICATOR	2
12	94136	SWITCH, LIMIT	2
13	94613	SOLENOID	1
14	710133	SCREW,HHWATAP 1/4X.50	2
15	710203	NUT, 1/4-20 HEXNYL 15X1 16	2
16	95420	WIRE, GROUND, 20.0"	1
17	710133	SCREW,HHWATAP 114X.50	1
18	94159	SWITCH, SEAT	1
19	302257	BATTERY 12V	1
20	710226	BOLT,1/4-20X.63CAR	2
21	710225	NUT, WING 1/4-20	2

WIRING SCHEMATIC

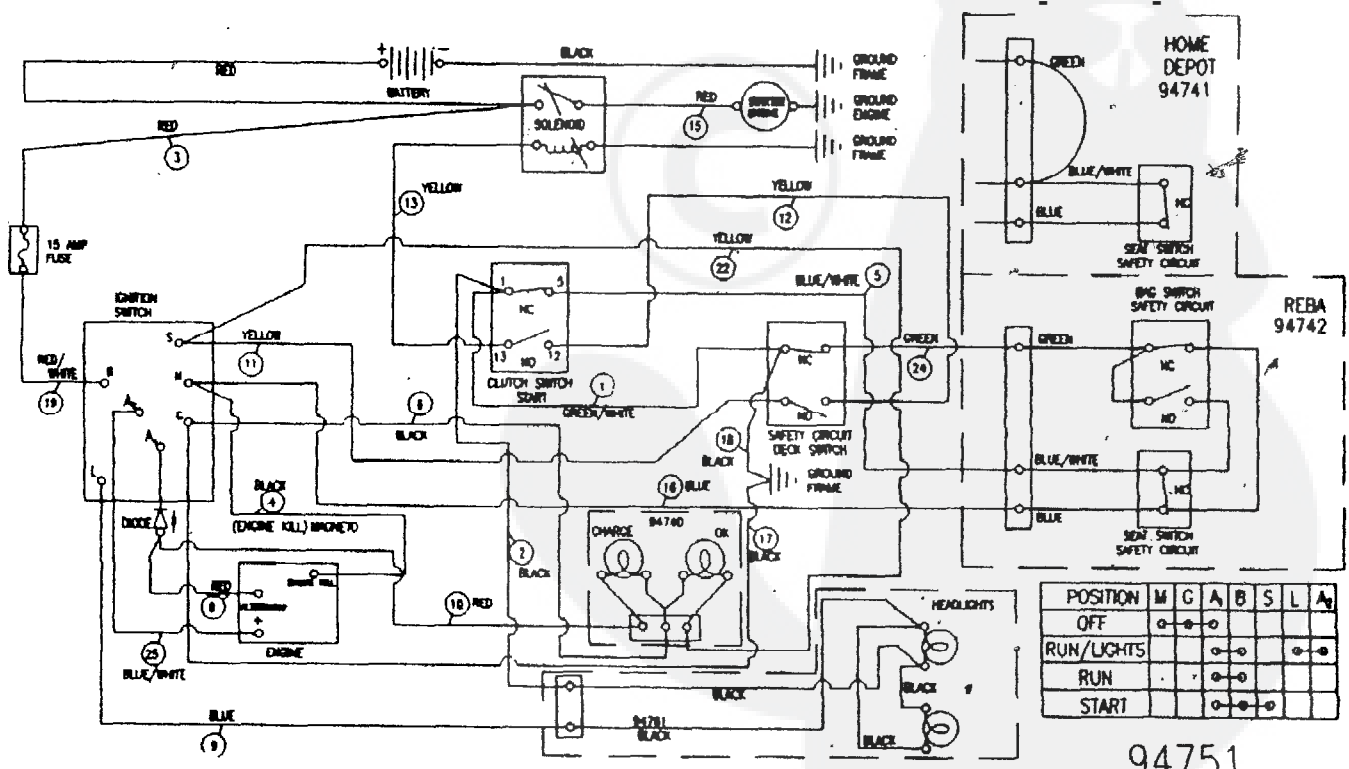

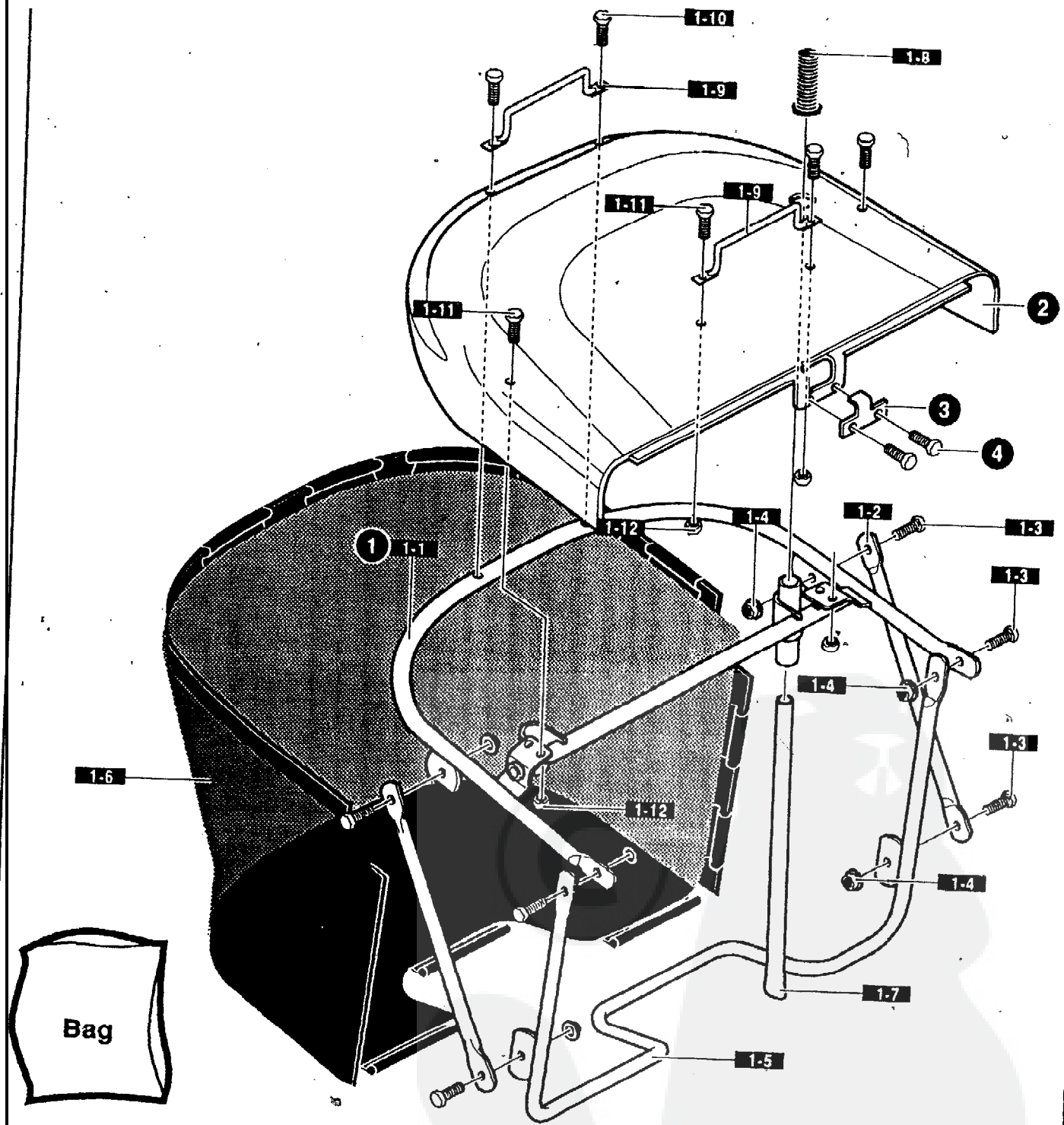

KEY NO.	PART NO.	DESCRIPTION	QTY
1	94560	ASM.GRASS COLLECTOR REBA	1
I-1	94849	ASSY., UPPER FRAME	1
I-2	94850	BRACE, FRAME COLLECTOR	2
I-3	180020	SCREW, 1/4-20X.75	6
I-4	1502	NUT, 1/4-20 REGHEXCTRLK	6
I-5	94851	ASSY., FRONT FRAME COLLECT	1
1 - 6	94852	BAG, REBA COLLECTOR	1
I-7	94853	HANDLE, DUMP REBA COLLECT.	1
I-8	94854	RUBBER GRIP 7/8" REBA	1
I-9	94855	HANDLE, REBA COLLECTOR	2
I-10	710266	SCREW, 10-24X.38 SLHWATAP	2
I-11	710266	SCREW, 10-24X.38 SLHWATAP	4
I-12	308459	NUT, #10-24 HXHDNYLK	4
2	94908-836	TOP COVER, COLLECTOR REBA	1
3	94244	BRACKET. SWITCH	1
4		RIVET, POP(NON SERVICEABLE PART)	

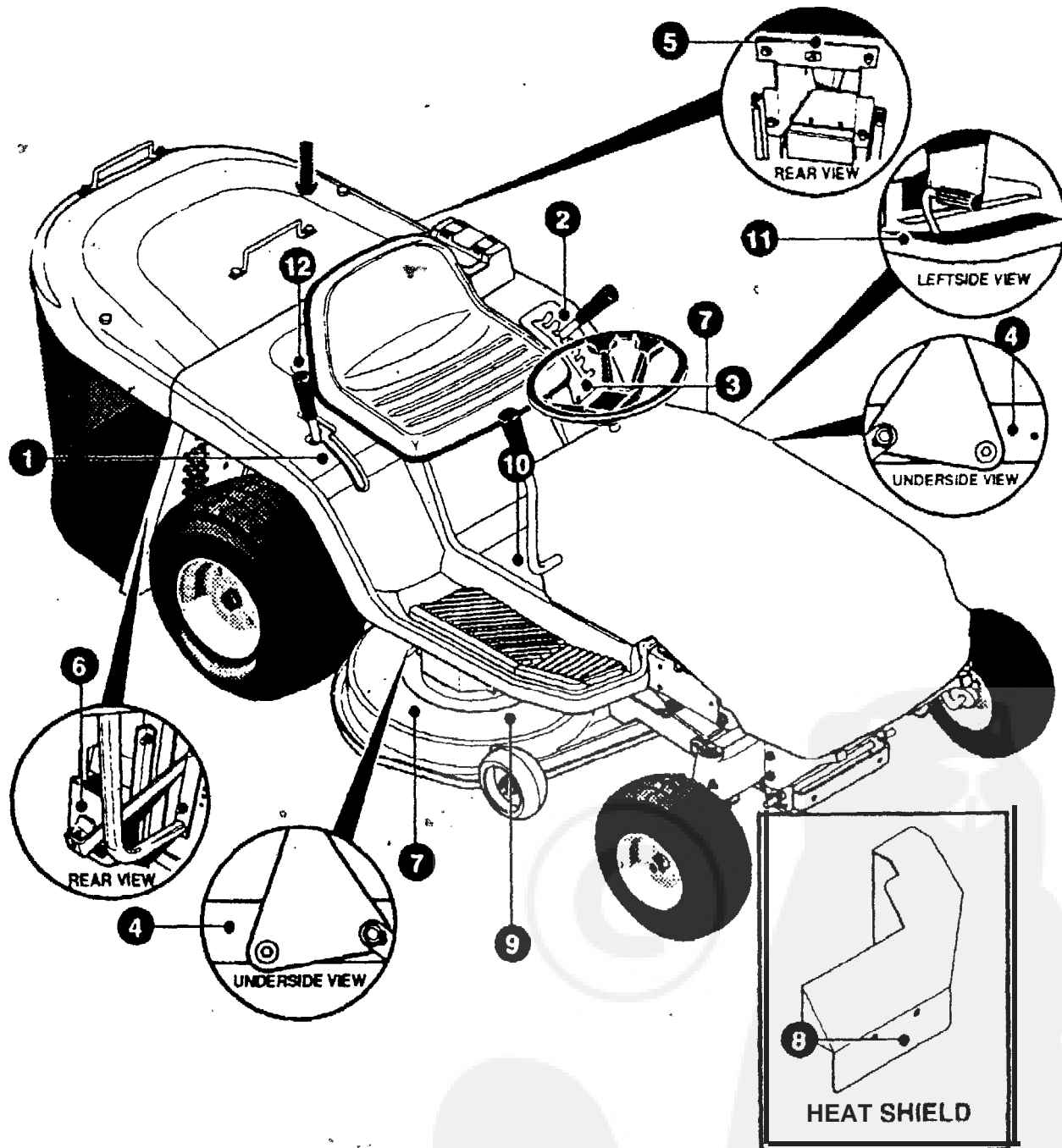

KEY NO.	PART NO.	DESCRIPTION	QTY
1	710558	DECAL, SHIFTER 6-SP REBA	1
2	710517	DECAL, HEIGHT ADJUST 6-POS.	1
	710683	DECAL, DECK LEVEL REBA/NLT EXP	1
a	710523	DECAL, PINCH POINTS WARNING	1
5	338541	DECAL, BAGGER "CE" M#44X5939	1
6	338542	DECAL, DRAWBAR WARN M#44X6138	1
7	402700	DECAL, CAUTION DECK LH	2
8	338543	DECAL, HOT SURF WARN M#44X5936	1
9	710684	DECAL, DECK BELT ROUTE REBA	1
10	710534	DECAL, CONS CAUT. M#44X6815	1
11	402702	DECAL, BRAKE/CLUTCH PICTOGRAM	1
12	318010	DECAL, TUV GS MO 44X2929	1

341271A

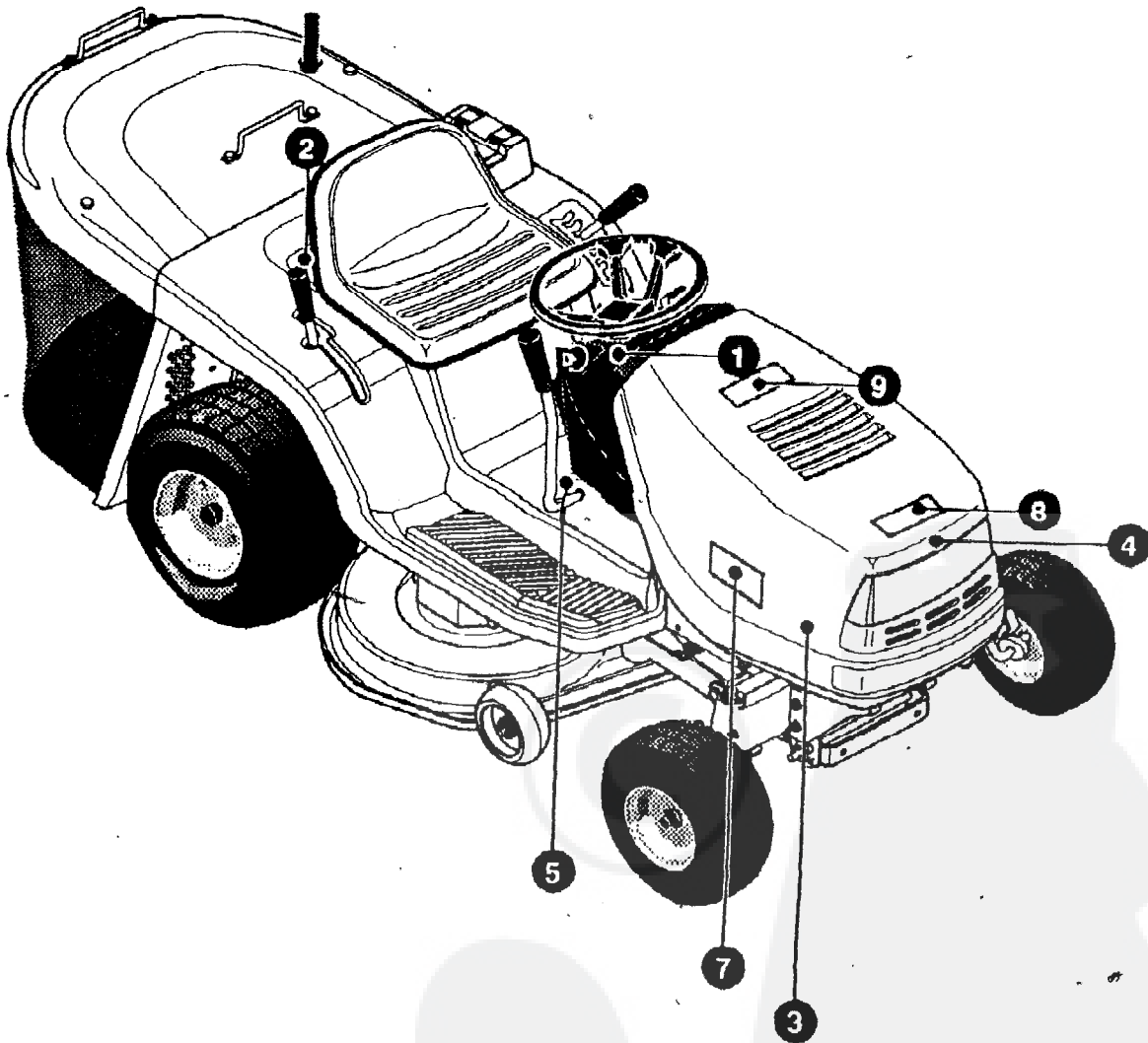

KEY NO.	PART NO.	DESCRIPTION	QTY
1	710615	DECAL, DASH CHOKE-A-MA	1
2		NOT A SERVICEABLE PART	
3	710866	DECAL, MIDORIMI11 OOR HOOD	2
4	402868	DECAL, HOOD "MIDORI"	1
5	710691	DECAL, PARK BRAKE (P)	1
7	305603	PAD, 18 X 6 FOAM HOOD	2
8	307276	PAD, 15 X 7 FOAM HOOD	1
9	307277	PAD, 12 X 4 FOAM HOOD	1

341744A