

REF:
CHASSIS REAR PG.
(SEAT DECK ASSY.)

NOTE: ALWAYS USE ORIGINAL EQUIPMENT PARTS.
Use of service/replacement parts other than original
equipment parts may void your warranty.

ALL UNNUMBERED
ITEMS ARE INTERCHANGEABLE
WITH OPPOSITE SIDE

341323B

KEY NO.	PART NO.	DESCRIPTION	QTY
1	95413-853	BRACKET/HOOD RH	1
2	95414-853	BRACKET/HOOD LH	1
3	710079	SCREW, 5/16-18X.75HHWATAPSGIBP	4
4	95427	D A S H	1
5	710282	SCREW, 1/4-14X.75PHPANTAPABBL	2
8	180020	SCREW, 1/4-20X.75 HHC	2
9	120392	WASHER, FLAT .281X.63X.065	4
10	780029	1/4-20 HEX NYLOCK NUT #71035	1
11	341569-860	ASM. LOWER CONSOLE	1
11-1	95425	TOWER, LOWER DASH	1
11-2	95426	SUPPORT, STEERING/PTO NLT	1
11-3	710264	SCREW, 1/4-20X.50 WAHHTAP	4
11-4	95406	ROD, DASH BRACE	1
11-5	710264	SCREW, 1/4-20X.50 WAHHTAP	2
12	710079	SCREW, 5/16-18X.75HHWATAPSGIBP	4
15	94638-860	PANEL, ACCESS	1
16	710196	SCREW, 1/10-24X.500	2
17	304188	HOOD	1
18	302670	LENS, HEADLAMP	1
19	308492	FOIL, LENS REFLECTOR	1
20	322700	DECAL, TAPE H14 8MIL VINYL	1
21	301452	FOIL, HEAT REFLECTOR	2
22	300317	PIN, CLEVIS .375DIA.X1.64LG	2
23	710343	PIN, HAIR .38DIA X1.66LG	2
24	6711	WASHER, PLASTIC .315X.75X.064	4
25	95404	BUSHING, STEERING SHAFT	1
	711105	OPERATOR'S MANUAL (NOT SHOWN)	

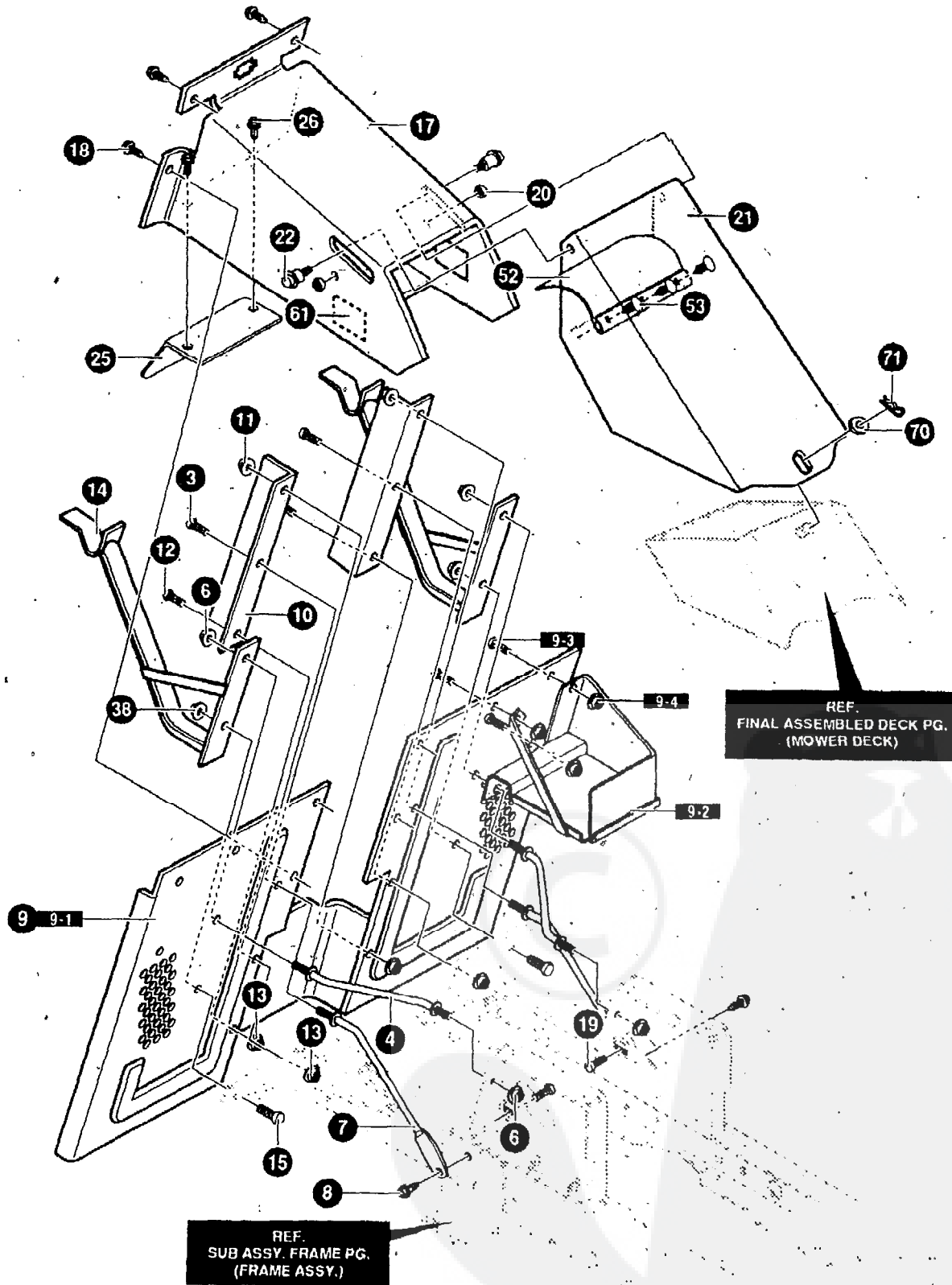

NOTE: ALWAYS USE ORIGINAL EQUIPMENT PARTS. Use of service/replacement parts other than original equipment parts may void your warranty.

ALL UNNUMBERED ITEMS ARE INTERCHANGEABLE WITH OPPOSITE SIDE

340926C

KEY NO.	PART NO.	DESCRIPTION	QTY
3	710079	SCREW, 5/16-18X.75	2
4	94625	ROD, BRACE	2
6	45171	NUT, 3/8-16 HWDFL WHIZ-LOCK	4
7	94231	ROD, BRACE	2
8	710079	SCREW, 5/16-18X.75HHWATAP	2
9	341493-853	BACK PLATE/BATTERY ASSEMBLY	1
9-1	94569	BACK PLATE ASSEMBLY	1
9-2	94563	BATTERY TRAY WELD ASM.	1
9-3	180073	SCREW, 5/16-18X.50 HHC	3
9-4	45174	NUT, 5/16-18 HEXWDFLLK WHIZ	3
10	94232-853	BRACE, BACK PLATE	2
11	45171	NUT, 3/8-16 HWDFL WHIZ-LOCK	2
12	328154	SCREW, 5/16-18X1.0WDFLLK	4
13	45174	NUT, 5/16-18 HEXWDFLLK WHIZ	4
14	94637-853	ASSY, COLLECTOR SUPPORT	2
15	328154	SCREW, 5/16-18X1.0WDFLLK	2
17	94295-853	CHUTE WELD ASM. UPPER	1
18	710079	SCREW, 5/16-18X.75HHWATAP	4
19	57101	BOLT, 5/16-18X.75 CARR	2
20	45174	NUT, 5/16-18 HEXWDFLLK WHIZ	2
21	94970-853	CHUTE MIDDLE ASSY	1
22	5.1601	BOLT, .500X.453 HSH 3/8-16	2
25	94263-853	COVER, T-AXLE SHIELD	1
26	710264	SCREW, 1/4-20X.50 WAHHTAP	2
52	94264	FLAP, CHUTE REBA	1
53	309235	RATCHET FASTENER	3
61	318197	PAD, ADHESIVE 1.00X1.50X12	2
70	710116	WASHER, FLAT .281X.63X.065	1
71	710343	PIN, HAIR .38DIAX1.64LG	1

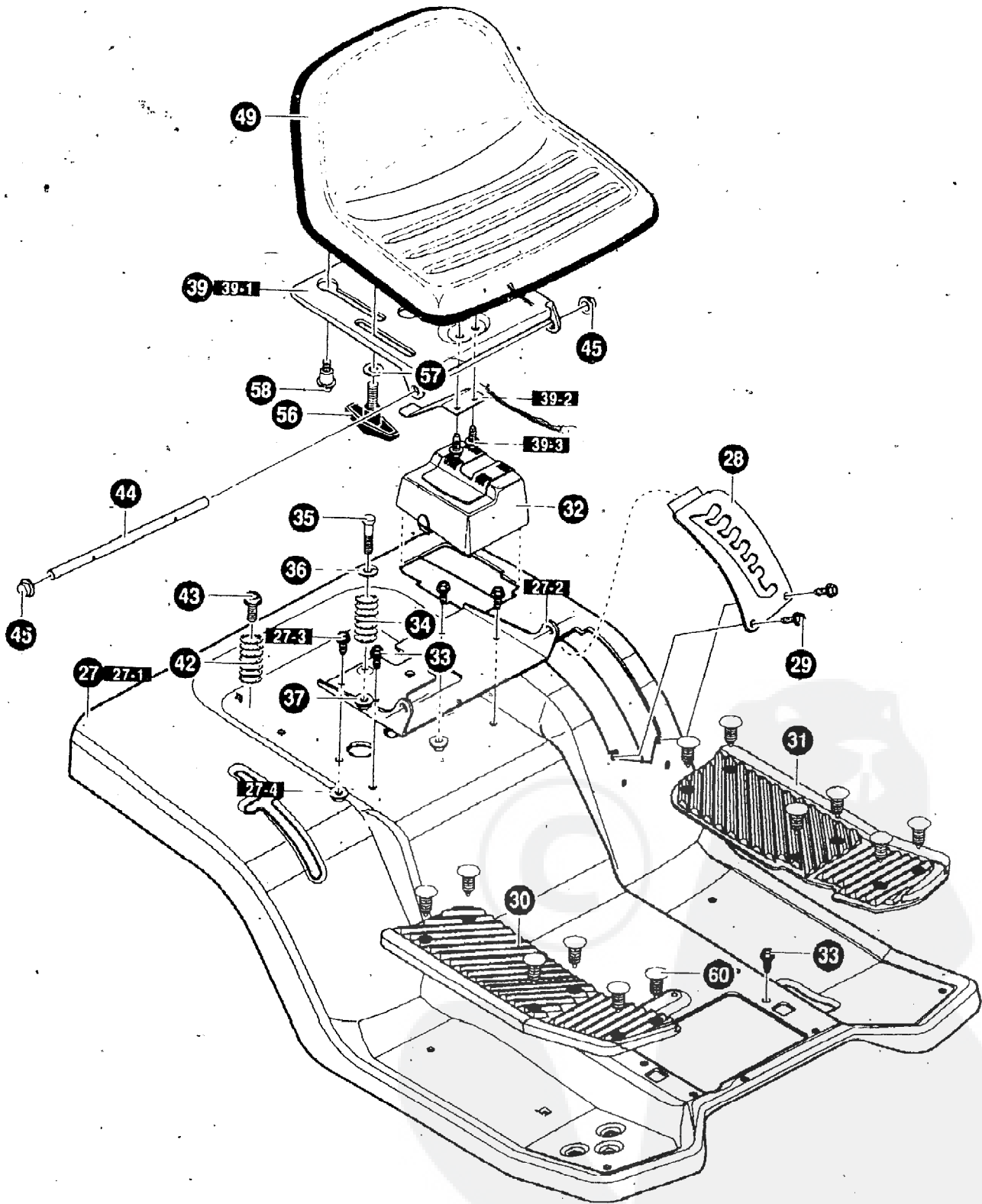

NOTE. ALWAYS USE ORIGINAL EQUIPMENT PARTS
 Use of service/replacement parts other than original
 equipment parts may void your warranty

ALL UNNUMBERED
 ITEMS ARE INTERCHANGEABLE
 WITH OPPOSITE SIDE



KEY NO.	P A R T NO.	DESCRIPTION	QTY
27	341496-860	ASM.SEAT DECK PEDAL GEAR REBA	1
27-1	94204	SEAT DECK,GEAR DRIVE	1
27-2	94153	BRACKET, PIVOT SEAT	1
27-3	710279	SCREW, 5/16-18X .625	2
27-4	710205	NUT, 5/16-18 WDFLLK (15X88)	2
28	94243-860	PLATE, LIFT DETENT	1
29	710196	SCREW, 10-24X.500TRSEGI	2
30	95438	FOOTREST PAD RH	1
31	95437	FOOTREST PAD LH	1
32	94200	COVER, BATTERY	1
33	710079	SCREW, 5/16-18X.75HHWATAP	3
34	710136	SPRING, COMPRESS 4.57LG X 1.17	1
35	71 0093	BOLTSHOULDER 1/4-20NC-2A(9X55)	1
36	94155	WASHER CUP ZINC	1
37	710280	NUT, 1/4-20 WDFLLK (15X89)	1
39	341494-860	ASSY. SEAT SUPPORT	
39 - 1	94154	SUPPORT, SEAT	1
39-2	94057	SPRING -LEAF	1
39-3	710264	SCREW, 1/4-20X.50 WAHHTAP	2
42	710109	SPRING,COMPRESS 2.43LG (164X30)	2
43	710079	SCREW, 5/16-18X.75HHWATAP	2
44	94156	ZINC HINGE SEAT PIVOT	1
45	710192	NUT, PUSH CAP .375 (28X23)	2
49	95415	SEAT	1
56	94160	BOLT, WING 5/16-18	2
57	710281	WASHER, FLAT.344X .62X.06	2
58	710101	BOLT, SHOULDER 5/16-18NC (9X56)	2
60	309235	FASTENER,RATCHET	12

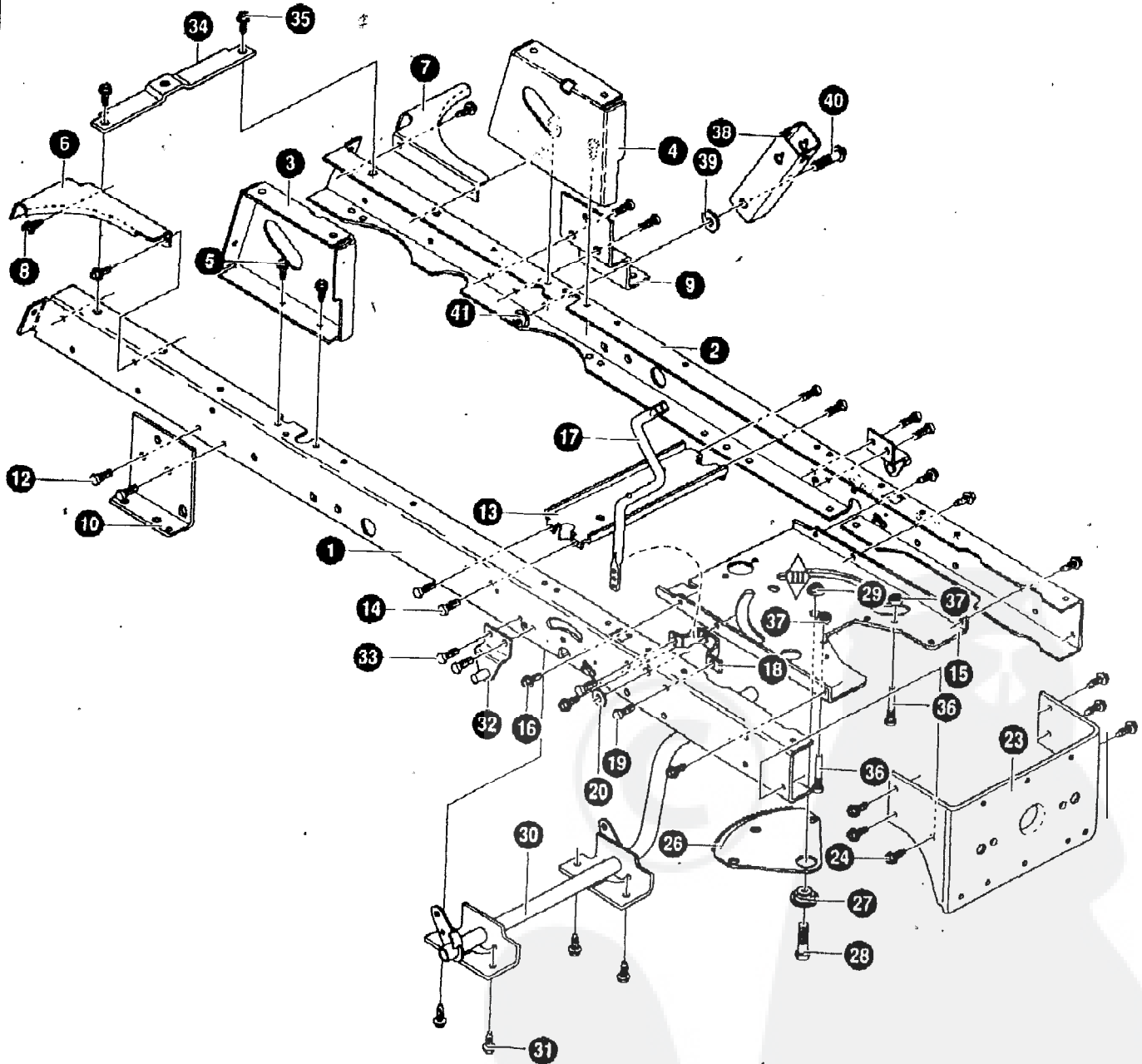

NOTE: ALWAYS USE ORIGINAL EQUIPMENT PARTS.
Use of service/replacement parts other than original
equipment parts may void your warranty.

ALL UNNUMBERED
ITEMS ARE INTERCHANGEABLE
WITH OPPOSITE SIDE

340413A

KEY PART NO. NO.	DESCRIPTION	QTY
1 94564	FRAME,RAIL RH	1
2 94565	FRAME,RAIL LH	1
3 94634	SUPPORT,SEAT RH	1
4 94633	SUPPORT,SEAT LH	1
5 710079	SCREW, 5/16-18X.75HHWATAP	4
6 94561	BRACE, BACKPLATE AH	1
7 94562	BRACE, BACKPLATE LH	1
8 710079	SCREW, 5/16-18X.75HHWATAP	4
9 94234	BRACKET,T/A RH-VST,LH-MST	1
10 94235	BRACKET,TRANSAXLE RH-MST	1
12 710079	SCREW, 5/16-18X.75HHWATAP	4
13 94237	ASM. IDLER MOUNT,FRONT	1
14 710079	SCREW, 5/16-18X.75HHWATAP	4
15 94003	PLATE,STEERING MOUNTING	1
16 710079	SCREW, 5/16-18X.75HHWATAP	6
17 94019	CRANK, PTO (DRILLED)	1
18 94005	BRACKET, BELL CRANK	1
19 710079	SCREW, 5/16-18X.75HHWATAP	2
20 120395	WASHER, FLAT .469X .92X.065	1
23 94013	BRACKET, HANGER REAR	1
24 710079	SCREW, 5/16-18X.75HHWATAP	6
26 94121	GEAR, SECTOR	1
27 94123	BEARING, SECTOR GEAR	1
28 710312	SCREW, 5/16-18X1.00	1
29 710105	NUT, 5/16-18HWDFLLK (15X113)	1
30 94241	ASM.CLUTCH/BRAKE PEDAL	1
31 710079	SCREW, 5/16-18X 75HHWATAP	4
32 94285	BRACKET SUPENSION ASM.	2
33 710079	SCREW, 5/16-18X.75HHWATAP	4
34 94566	BRACE, RAIL	1
35 710079	SCREW, 5/16-18X.75HHWATAP	2
36 93349	SCREW GUIDE 5/16-18	2
37 710204	NUT,5/16-18 HEXWDFLLK WHIZ PL	2
38 9401-5	BRACKET, PIVOT	1
39 845	WASHER, FLAT .390X1.25X.119	1
40 710000	BOLT, .562X1.563 HSH 3/8-16	1
41 710140	NUT,3/8-16HWDFLLK MACK (15X84)	1

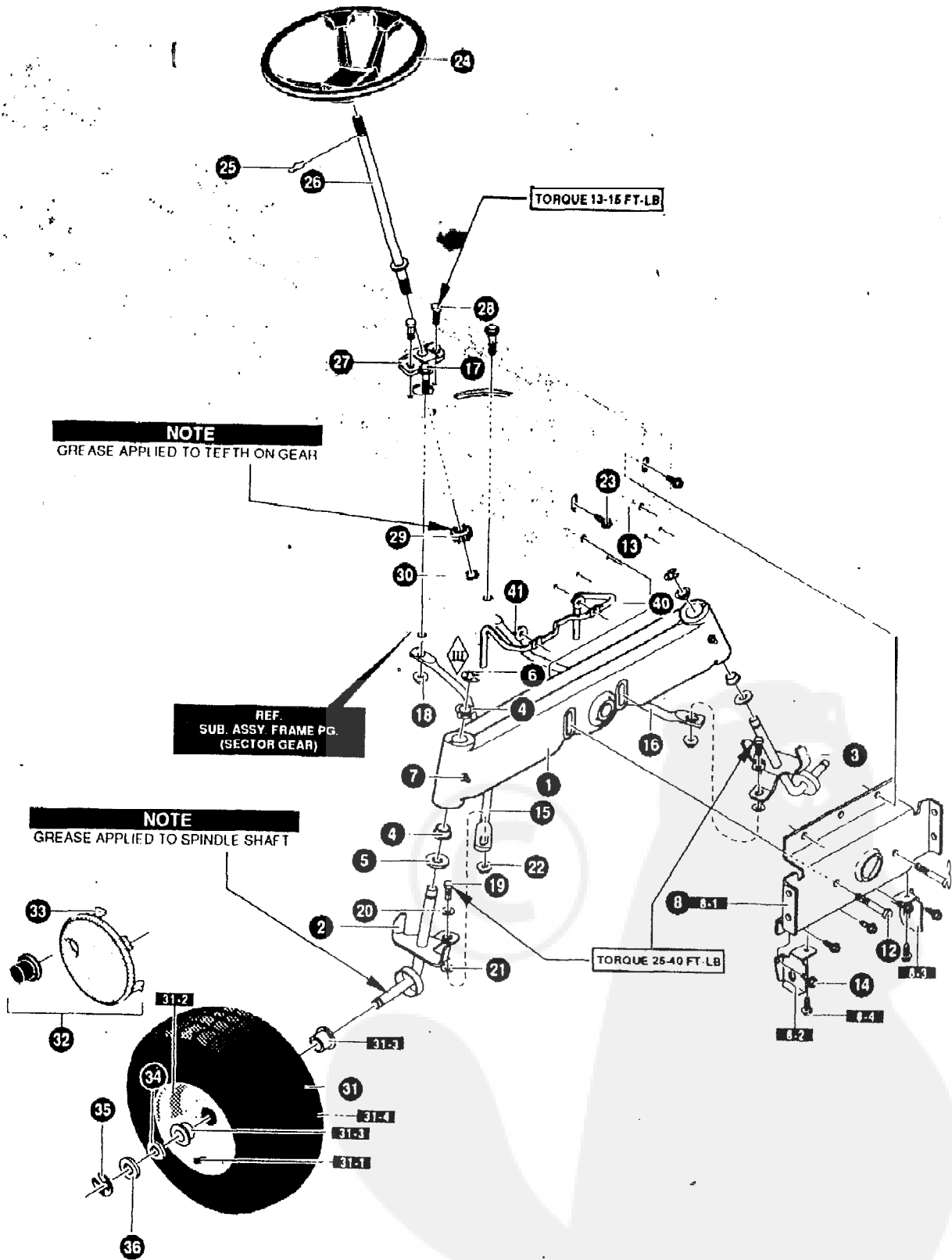

NOTE: ALWAYS USE ORIGINAL EQUIPMENT PARTS
 Use of service/replacement parts other than original
 equipment parts may void your warranty.

ALL UNNUMBERED
 ITEMS ARE INTERCHANGEABLE
 WITH OPPOSITE SIDE

340597A

KEY NO.	PART NO.	DESCRIPTION	QTY
1	95405-853	AXLE, CAST MACHINED	1
2	94 178-853	SPINDLE, RH MO#94178	1
3	94179-853	SPINDLE LH, WELD ASSEMBLY	1
4	92527	BEARING, SPINDLE	4
5	710129	WASHER, .766 ID X 1.62 ID 16GA	2
6	710103	E-RING .574 ID X .050 / .750 SH 11 X3	2
7	706	ZERK, GREASE FITTING	2
8	341491-853	ASM. FRONT AXLE/DECK HANGER	1
8-1	94007	HANGER, AXLE	1
8-2	94290	HANGER, DECK RH	1
8-3	94289	HANGER, DECK LH	1
8-4	710079	SCREW, 5/16-18X.75HHWATAPSGIBP	2
12	180113	SCREW, 5/16-18X3.00	2
13	710205	NUT, 5/16-18 WDFLLK (15X88) Z	2
14	710079	SCREW, 5/16-18X.75HHWATAPSGIBP	2
15	94020-853	DRAG LINK RH	
16	9402 1-853	DRAG LINK LH	1
17	710440	BOLT, HSSH (9X57)	2
18	710140	NUT, 3/8-16HWDFLLK MACK 15X84	2
19	710082	SCREW, 3/8-16X1.5	2
20	710083	WASHER, FLAT .391 XI .00X.083	2
21	710142	WASHER, FLAT .406X.81X16GA	2
22	710140	NUT, 3/8-16HWDFLLK MACK 15X84 Z	2
23	710079	SCREW, 5/16-18X.75HHWATAPSGIBP	3
24	9544 1	STEERING WHEEL	1
26	94127	SHAFT, STEERING	1
27	94124	BEARING-LOWER	1
28	710079	SCREW, 5/16-18X.75HHWATAPSGIBP	2
2 9	94122	GEAR PINNION	1
30	710102	RING, RET E.54 ID.59 SH (1 1X25)	1
31	692287	TIRE & RIM	2
31-1	338512	VALVE STEM	2
31-2	3385 17	RIM, CARLISLE	2
31-3	338513	BEARING	2
31-4	338516	TIRE, 15X6X6	2
34	710131	WASHER, FLAT .759 ID (340435)	2
35	36625	RETAINING RING	2
36	710350	WASHER, FLAT .765X1.62X.065Z	2
40	94310	GUIDE-STACK PULLEY BELT	1
41	45174	NUT, 5/16-18 HEXWDFLLK WHIZ	2

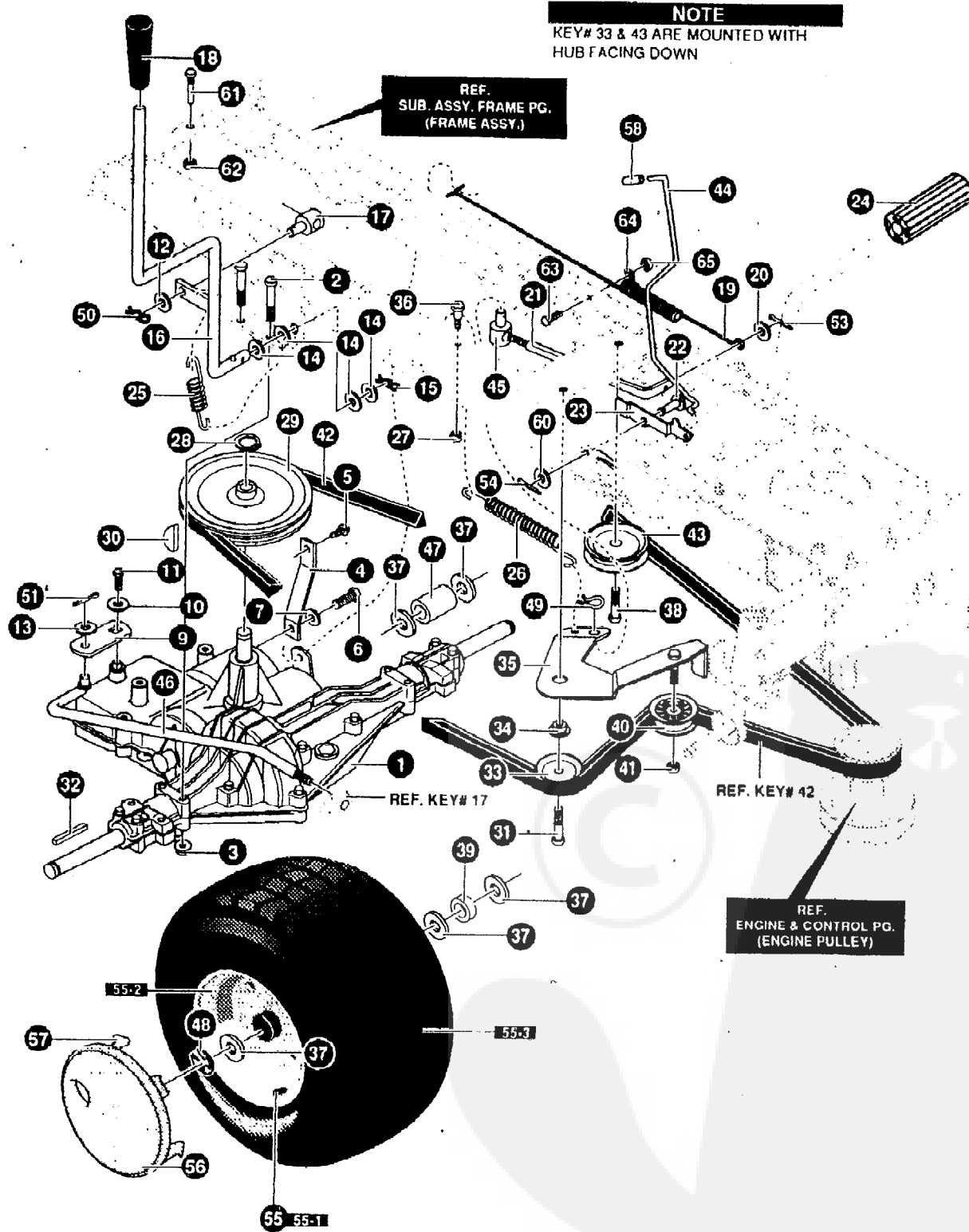

NOTE: ALWAYS USE ORIGINAL EQUIPMENT PARTS
 Use of service/replacement parts other than original
 equipment parts may void your warranty.

ALL UNNUMBERED
 ITEMS ARE INTERCHANGEABLE
 WITH OPPOSITE SIDE

3404700

KEY NO.	PART NO.	DESCRIPTION	QTY
1		TRANSAXLE <u>MST206-512A</u>	1
2	180091	SCREW, 5/16-18X2.50	4
3	710205	NUT, 5/16-18 WDFLLK (15X88)	4
4	94620-853	BRACKET, STABILIZER	1
5	710079	SCREW, 5/16-18X.75HHWATAP	1
6	35490	SCREW, 5/16-18X.75 WAHHTAP	1
7	120638	WASHER, HVSPTLK .328X.60X.09	1
9	94227	BRKT, SHIFT FENDER HT	1
10	57157	WASHER, .750X.250 SP-TRANSAXLE	1
11	56255	SCREW, 1/4-28X .75 NYL	1
12	9964 16	WASHER, FLAT .391X 1.00X. 125	1
13	120394	WASHER, FLAT .406X .81X.065	1
14	996425	WASHER, FLAT .515X.88X.064	4
15	56180	PIN, HAIR .53DIAX1.62LG	1
16	94242	SHIFT LEVER, MST GEAR DRIVE	1
17	21920	NUT, ADJ. 3/8-16TAP	1
18	92697	GRIP, BLACK HEIGHT ADJ	1
19	95424	SPRING, BRAKE 35.00	1
20	35214	WASHER, FLAT .328X1.06X.062	1
21	945 73	ROD, CLUTCH	1
22	49332	PIN, CLEVIS .375DX.81LG	1
23	94045	LATCH, PARK BRAKE	1
24	21544	PEDAL, BRAKE/CLUTCH STD NLT	1
25	35410	SPRING .071X .62 X 4.37	1
26	710139	SPRING, TENS .09X .X5.	1
27	780029	1/4-20 HEX NYLOCK NUT #71035	1
28	22053	RING, RETEX .58X.035TRU5100-62	1
29	94571	PULLEY, 9.0 OD V4L T/A	1
30	50795	KEY, HI-PRO 606 .75DIAX.187WD	1
31	710082	SCREW, 3/8-16X1.5 HHCFLTHR5	1
32	52928	KEY, SQUARE .187SQX2.25LG	2
33	35374	PULLEY, IDLER V4L 3.06X .62	1
34	95423	SPACER, SHOULDER	1
35	94238-853	ASSY. IDLER ARM TRACTION	1
36	310088	BOLT, .250X.312 HSSH 1/4-20	1
37	710131	WASHER, FLAT .775ID	6
38	180124	SCREW, 3/8-16X1.25	1
39	95418	SPACER, .87 X 1.25 WHEEL	2
40	91179	PULLEY	1
41	45905	NUT, 3/8-16HWDFLLK MACK	1
42	94608	BELT, V 4L 114.12	1
43	35374	PULLEY, IDLER V4L 3.06X .62	1
44	94568	PARK BRAKE CONTROL ROD	1
45	710059	NUT, 5/16-18X3/8 ADJUSTING	1
46	94570	ROD, SHIFT LINK	1
47	95419	SPACER, .87 X 2.25 WHEEL	1
48	36625	RING, RETEX .57X.05TRU5133-75	2
49	56180	PIN, HAIR .53DIAX1.62LG	1
50	340470	PIN, HAIR .38DIAX1.64+LG	1
51	121222	PIN, COTTER 090 DIAX.75LG	1
53	121222	PIN, COTTER .090 DIAX.75LG	1
54	121222	PIN, COTTER .090 DIAX.75LG	1
55	692289	TIRE & RIM	2
55-1	338512	VALVE STEM	1
55-2	338524	RIM	1
55-3	338549	TIRE 18X8.5X8	1
58	335980	CAP, DUMP VALVE ROD.25IDX.75	1
60	120394	WASHER, FLAT .406X .81X.065	1
61	20619	SCREW GUIDE 5116-18	1
62	710204	NUT, 5/16-18 HEXWDFLLK WHIZ	1
63	180016	SCREW, 114-20X.50	1
64	57569	RETAINER, WIRE	1
65	51335	NUT, 1/4-20 WHIZ-LOCK	1

. CONTACT YOUR NEAREST TRANSAXLE DEALER FOR PARTS AND SERVICE.

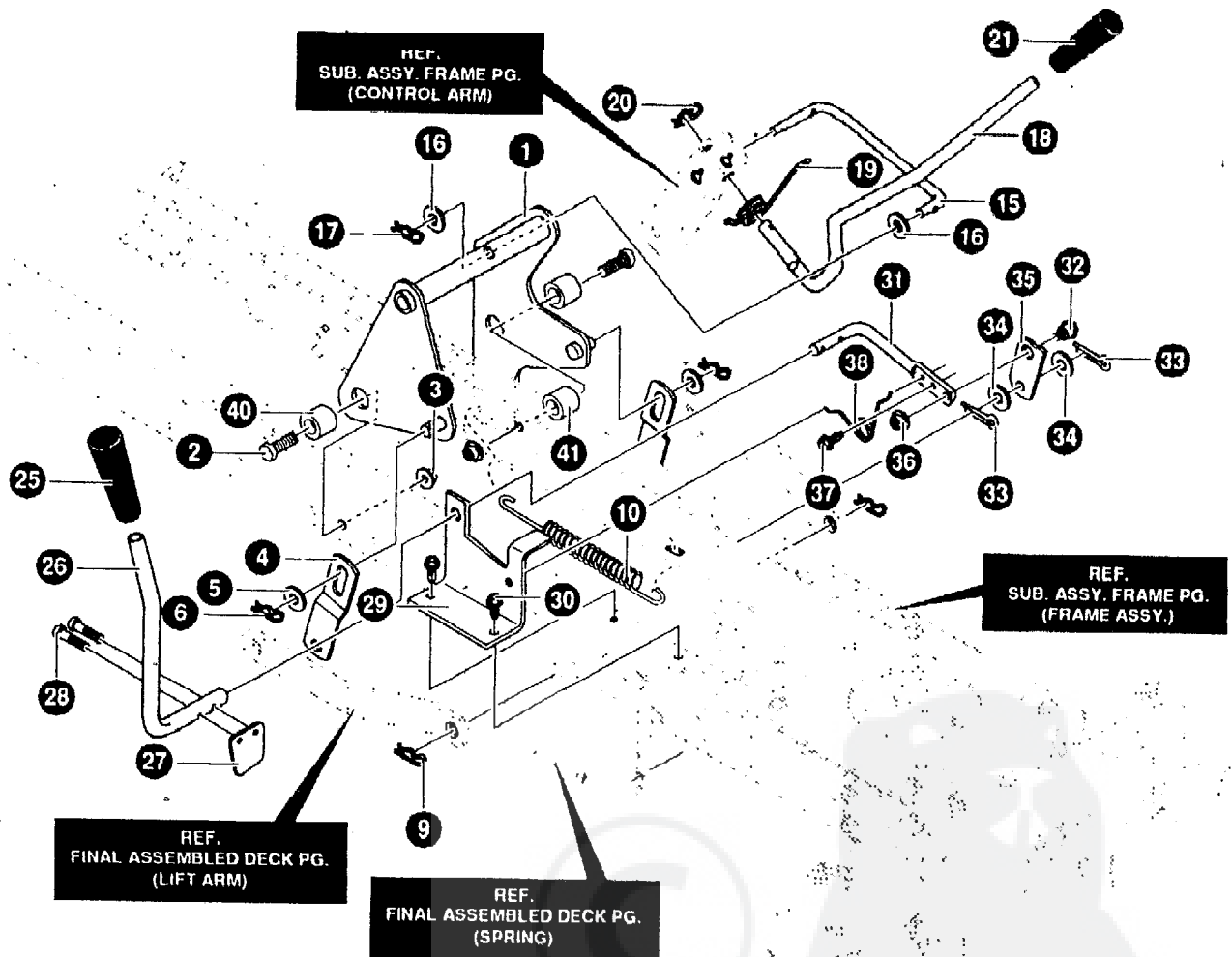

NOTE: ALWAYS USE ORIGINAL EQUIPMENT PARTS.
Use of service/replacement parts other than original
equipment parts may void your warranty.

ALL UNNUMBERED
ITEMS ARE INTERCHANGEABLE
WITH OPPOSITE SIDE

34085%

KEY NO.	PART NO.	DESCRIPTION	QTY
1	94299-853	LIFT ARM WELD ASSEMBLY	1
2	710222	SCREW, 1/2-13X1.50 (1X127)	2
3	710223	NUT, 1/2-13 LOCK (15X41)	2
4	94262-853	BRACKET, LIFT LINK	2
5	710119	FLATWASHER (17X91)	2
6	710108	PIN, HAIR (31X4)	2
9	710108	PIN, HAIR (31X4)	2
10	710235	SPRING, EXTENSION 9.82X1.01OD	1
15	94276	LINK, LIFT HANDLE	1
16	710119	FLATWASHER (17X91)	2
17	8260	PIN, HAIR .091 DIA X 1.66 LG	1
18	94029	HANDLE, LIFT	1
19	710111	TORSION SPRING .657 LG (166X40)	1
20	710108	PIN, HAIR (31X4)	1
21	92697	GRIP, BLACK	1
25	92698	GRIP, BLACK	1
26	94826	PTO LEVER	1
27	94022	PADDLE, SWITCH	1
28	710137	SCREW, THD FORMING	2
29	94018-853	BRACKET, PTQ	1
30	710079	SCREW, 5/16-18X.75 HHHWATAP	2
31	94017	LEVER, PTO	1
32	710098	BOLT .50X.75 HSSH 3/8-16Z 9X39	1
33	36368	HAIR PIN	2
34	710115	FLATWASHER .518X.87X16 17X102	2
35	94004	LINK PTO ZINC	1
36	710140	NUT, 3/8-16HWDFLLK MACK (15X84)	1
37	71.0079	SCREW, 5/16-18X.75 HHHWATAP	1
38	710141	TORSION SPRING .33 LG (166X39)	1
40	94309	SPACER .513 ID X .880 OD	2
41	56150	SPACER, SLEV .94X1.13X.531	1

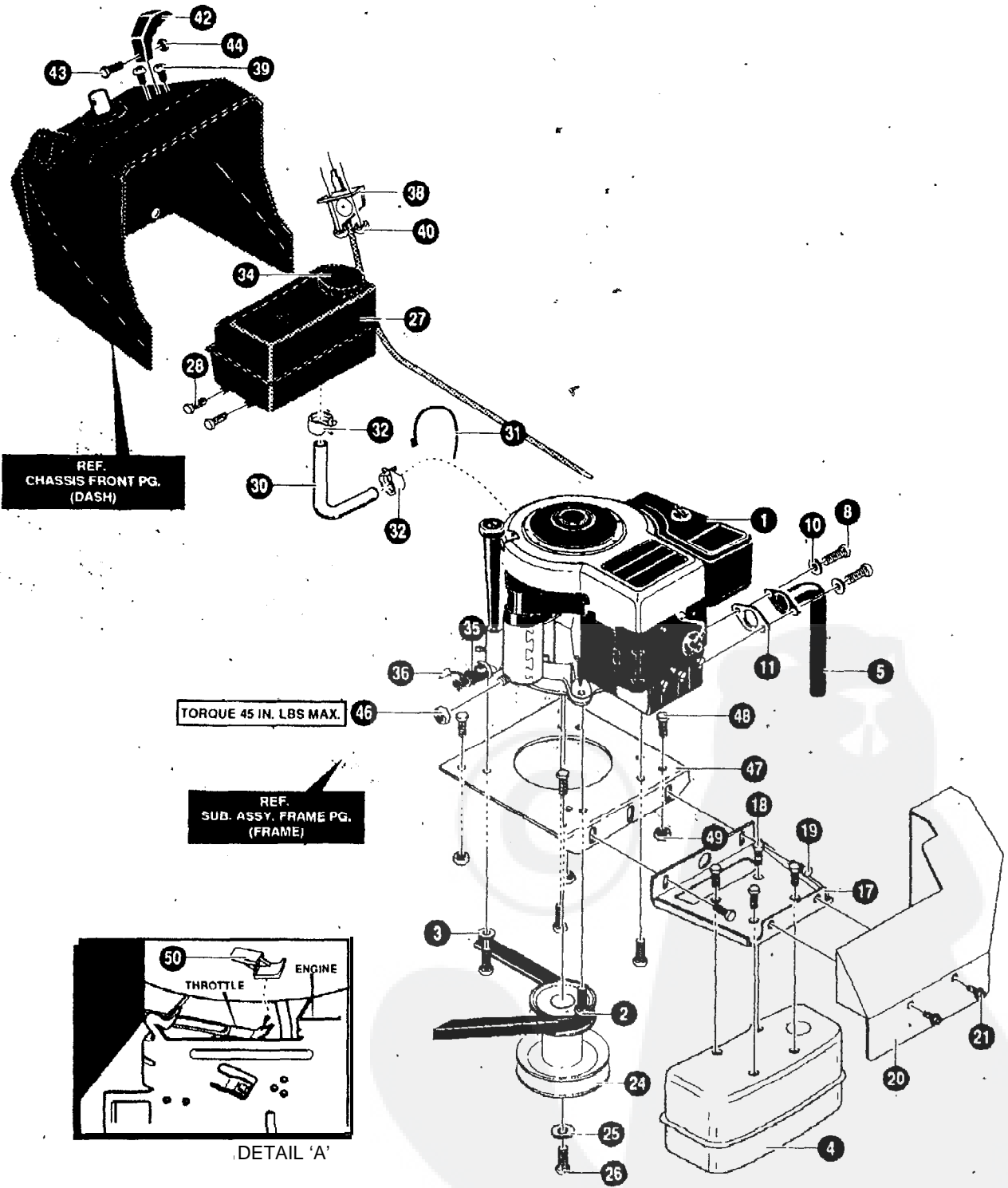

NOTE: ALWAYS USE ORIGINAL EQUIPMENT PARTS
 Use of service/replacement parts other than original
 equipment parts may void your warranty.

ALL UNNUMBERED
 ITEMS ARE INTERCHANGEABLE
 WITH OPPOSITE SIDE

3416068

KEY NO.	PART NO.	DESCRIPTION	QTY
1	(289707-0121-01) ENGINE	12.5HPBASIC NON QUIET (SEE ENGINE MANUAL)	1
2	50947	SCREW, 3/8-16X1.25	4
3	138489	WASHER, EXLK .384X.69X.04	1
4	94902	MUFFLER, SUPER LOW TONE 12.5	1
5	94900	EXHAUST PIPE 12.5 B&S	1
8	180077	SCREW, 5/16-18X.75 HHC	2
10	120638	WASHER, HVSP TLK .328X.60X.09	2
11	46708	GASKET, MUFFLER	1
17	94901-853	BRACKET MUFFLER, 12.5HP	1
18	44811	SCREW, 1/4-20X.75	4
20	94904-853	HEAT SHIELD WELD ASSY.	1
21	710079	SCREW, 5/16-18X.75HHWATAPSGIBP	2
24	94308	PULLEY, ENGINE 4.89X6.75X5.4OFF	1
25	i 20383	WASHER, REGSPTLK.459X.78X.12	1
26	433146	SCREW, 7/16-20X4.25	1
27	309853	TANK, FUEL 1.5 WO/SENSOR CLEAR	1
28	710246	SCREW, 15TPIX. PANHTAP	4
30	50118	TUBING, .25X.50X BULK GAS LINE	12"
31	57444	TIE, CABLE BLACK	1
32	47345	CLAMP, HOSE SCREW	1
34	12501	CAP, FUEL 2.5" THROAT	1
35	325547	OIL DRAIN VALVE ASSEMBLY	1
36	327422	CAP, OIL DRAIN VALVE	1
38	94906	THROTTLE CONTROL	1
39	155941	SCREW, 10-24X.63	2
40	308459	NUT, #1 O-24	2
42	300508	KNOB, THROTTLE CONTROL	1
43	159585	SCREW, #8-32X.38 PHPNMA	1
44	120622	NUT, #8-32 REGHX	1
46	124818	NUT, 1/4-20 REGHXJAM	1
47	94006-853	PLATE, ENGINE	1
48	710079	SCREW, 5/16-18X.75	4
49	710205	NUT, 5/16-18 WDFLLK (15X88)	4
50	94951	CLIP. SPEED	1

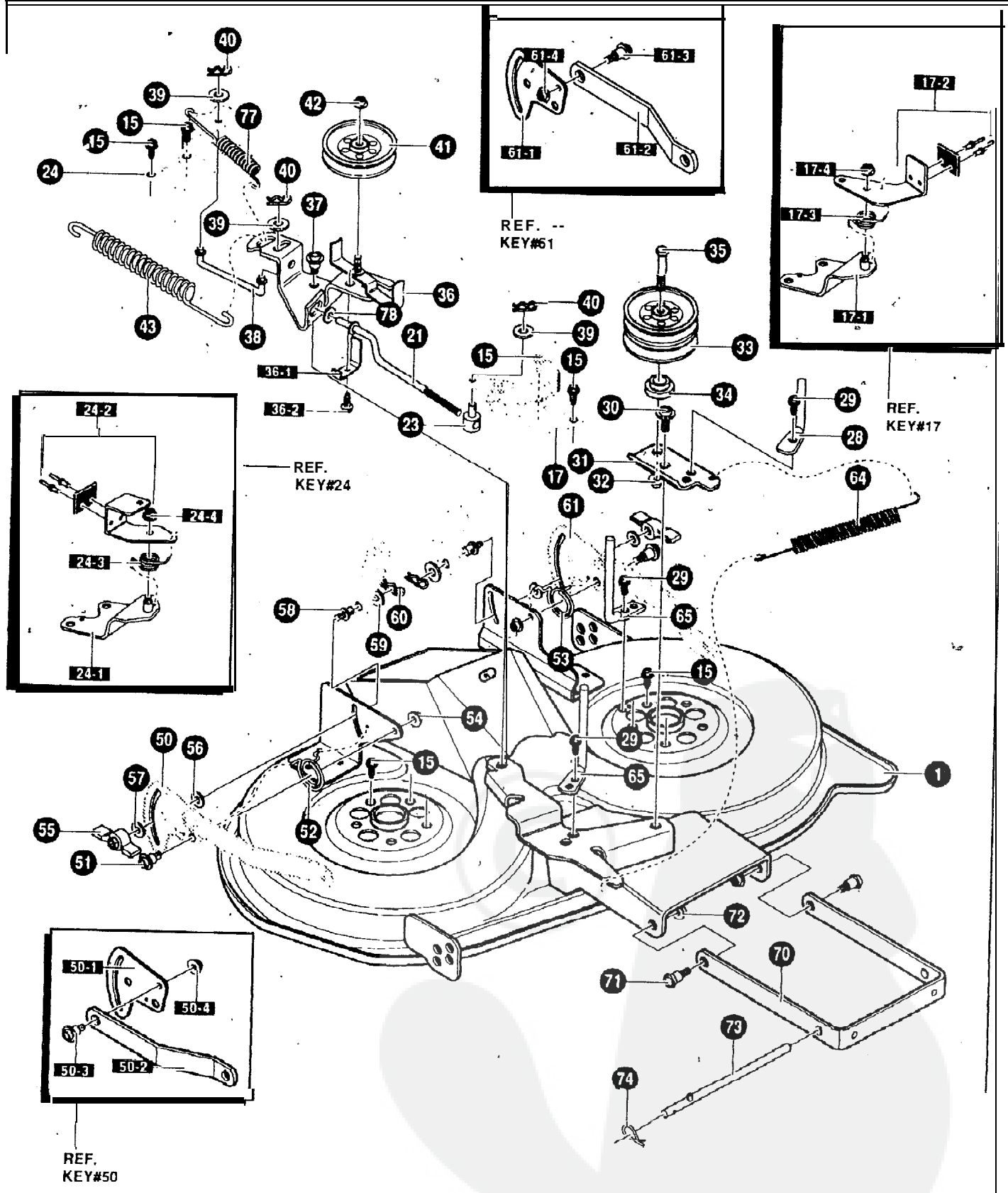

NOTE: ALWAYS USE ORIGINAL EQUIPMENT PARTS
 Use of service/replacement parts other than original
 equipment parts may void your warranty.

ALL UNNUMBERED
 ITEMS ARE INTERCHANGEABLE
 WITH OPPOSITE SIDE

KEY NO.	PART NO.	DESCRIPTION	QTY
1	94303-853	WELD ASSEMBLY DECK	1
15	710265	SCREW, 3/8-16X1.00 WAHHSPTAPPL	10
17	94665-853	BRAKE ARM ASSEMBLY LH	1
17-1	94293	BRAKE SUPPORT ASSEMBLY LH	1
17-2	94291	BRAKE ARM ASSEMBLY LH	1
17-3	710110	SPRING, TORSION (166X27)	1
17-4	710205	NUT, 5/16-18 WDFLLK (15X88)	1
23	94277	LINK, BRAKE LH	1
24	21920 94664-853	BRAKE ARM ASSEMBLY RH	1
24-1	94294	BRAKE SUPPORT ASSEMBLY RH	1
24-2	94292	BRAKE ARM ASSEMBLY RH	1
24-3	710205	NUT, 5/16-18 WDFLLK (15X88)	1
28	94274	GUIDE, BELT REBA	1
29	710114	SCREW, 5/16-18 50HHTAP	3
30	710098	BOLT, 50X.75 HSH 3/8-16Z 9X39	1
31	9426 I-853	ARM, DOUBLE IDLER	1
32	710140	NUT, 3/8-16HWDFLLK MACK 15X84	1
33	9 4 2 7 9	PULLEY, IDLER DOUBLE VEE	1
34	94269	SPACER, REBA DECK	1
35	180138	SCREW, 3/8-16X3.00 HHC	1
3 6	94973-853	IDLER ARM ASSEMBLY	1
36-1	94312	SPRING, GUIDE B E L T	1
36-2	7 10264	SCREW, 114-20X.50 WAHHTAP	1
38	710098	BOLT, 50X.75 HSH 3/8-16Z 9X39	1
39	94278	LINK, BRAKE RH	1
	316079	WASHER, FLAT .406X.82X.040	1
40	710343	PIN, HAIR .38DIA X1.64LG	3
41	94280	PULLEY, V IDLER d"	1
42	710140	NUT, 3/8-16HWDFLLK MACK 15X84	1
43	710234	SPRING, EXTN 5.40X.71400	1
50	341593-853	PLATE SUSPENSION ASSY	1
50-1	94128	PLATE - SUSPENSION	1
50-2	94055	SUSPENSION BRKT REAR	1
50-3	710095	SHOULDER BOLT 3/8-16 (9X52)	1
50-4	710140	NUT, 3/8-16 MACK (15X84)	1
51	710094	BOLT, SHOULDER .375 (9X51)	2
52	710112	SPRING, TORSION .68LG RH (166X42)	1
53	710113	SPRING, TORSION .68LG LH (166X43)	1
54	710140	NUT, 3/8-16HWDFLLK MACK (15X84)	2
55	94068	KNOB	2
			2
56	94105 7	WASHER (17X45)	2
58	94064	PIN, HANGER	2
59	710116	WASHER, FLAT .550X1.00X11 (17X103)	2
60	710108	PIN, HAIR (31X4)	2
61	341594-853	ASM. PLATE REAR SUS BRKT LH	1
61-1	94128	PLATE - SUSPENSION	1
61-2	94055	SUSPENSION BRKT REAR	1
61-3	710095	SHOULDER BOLT 3/8-16 (9X52)	1
61-4	710140	NUT, 3/8-16 MACK (15X84)	1
64	710233	SPRING, EXTN 4.20X.7500	1
65	94275	GUIDE BELT	2
70	94058-853	BRACKET, FRT SUSPENSION	1
71	710094	BOLT, SHOULDER .375 (9X51)	2
72	710140	NUT, 3/8-16HWDFLLK MACK (15X84)	2
73	941588	PIN, ROD HANGER (31X4)	1
			1
77	710658	SPRING, EXTENSION	1
76	996416	WASHER, FLAT .391X1.00X.125	1

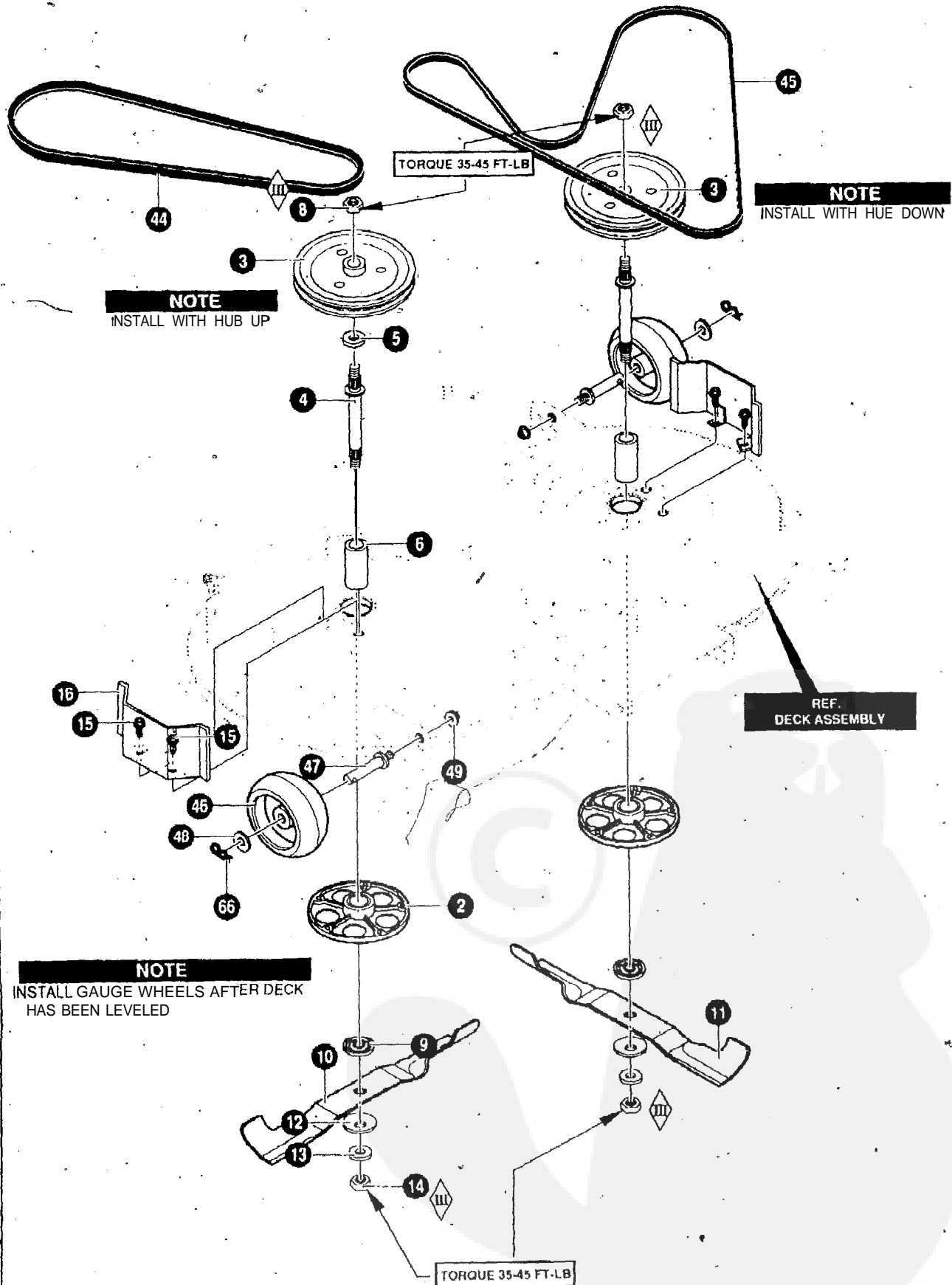

NOTE
INSTALL WITH HUB UP

NOTE
INSTALL WITH HUE DOWN

REF.
DECK ASSEMBLY

NOTE
INSTALL GAUGE WHEELS AFTER DECK
HAS BEEN LEVELED

TORQUE 35-45 FT-LB

NOTE. ALWAYS USE ORIGINAL EQUIPMENT PARTS.
Use of service/replacement parts other than original
equipment parts may void your warranty.

ALL UNNUMBERED
ITEMS ARE INTERCHANGEABLE
WITH OPPOSITE SIDE

KEY NO.	PART NO.	DESCRIPTION	QTY
2	94305	ASM.JACKSHAFT HOUSING W/VENTS	2
3	92425	PULLEY, DECK REBA	2
4	91922	JACKSHAFT, 7.76LG-9/16-18TH	2
5	710117	WASHER,FLAT .625X1.00X.188	1
6	91903	SPACER	2
8	710408	NUT, 9/16-18 CTRLK (15X101)	2
9	94207	ADAPTER, DECK/BLADE	2
10	94208	BLADE, 40" RH REAR DISCHARGE	1
11	94209	BLADE, 40" LH REAR DISCHARGE	1
12	710118	WASHER, FLAT.625X1.75 17X1 66	2
13	710117	WASHER,FLAT .625X1.00X.188	2
14	710408	NUT, 9/16-18 CTRLK-15X101	2
15	710265	SCREW, 3/8-16X1 .00 WAHHSPTAPPL	10
16	94288-853	COVER PULLEY	2
44	710231	BELT, V	1
45	710232	BELT, V- 40" DECK	1
46	92683	GAUGE WHEEL,4.94 DJA.	2
47.	94025	BOLT, SPSH 3/8-16X.63SH3.00LG	2
48	710115	WASHER,FLAT.518X.87X16 17X102	2
49	710140	NUT,3/8-16HWDFLK MACK 15X84	2
66	710108	HAIR PIN (31 X4)	2

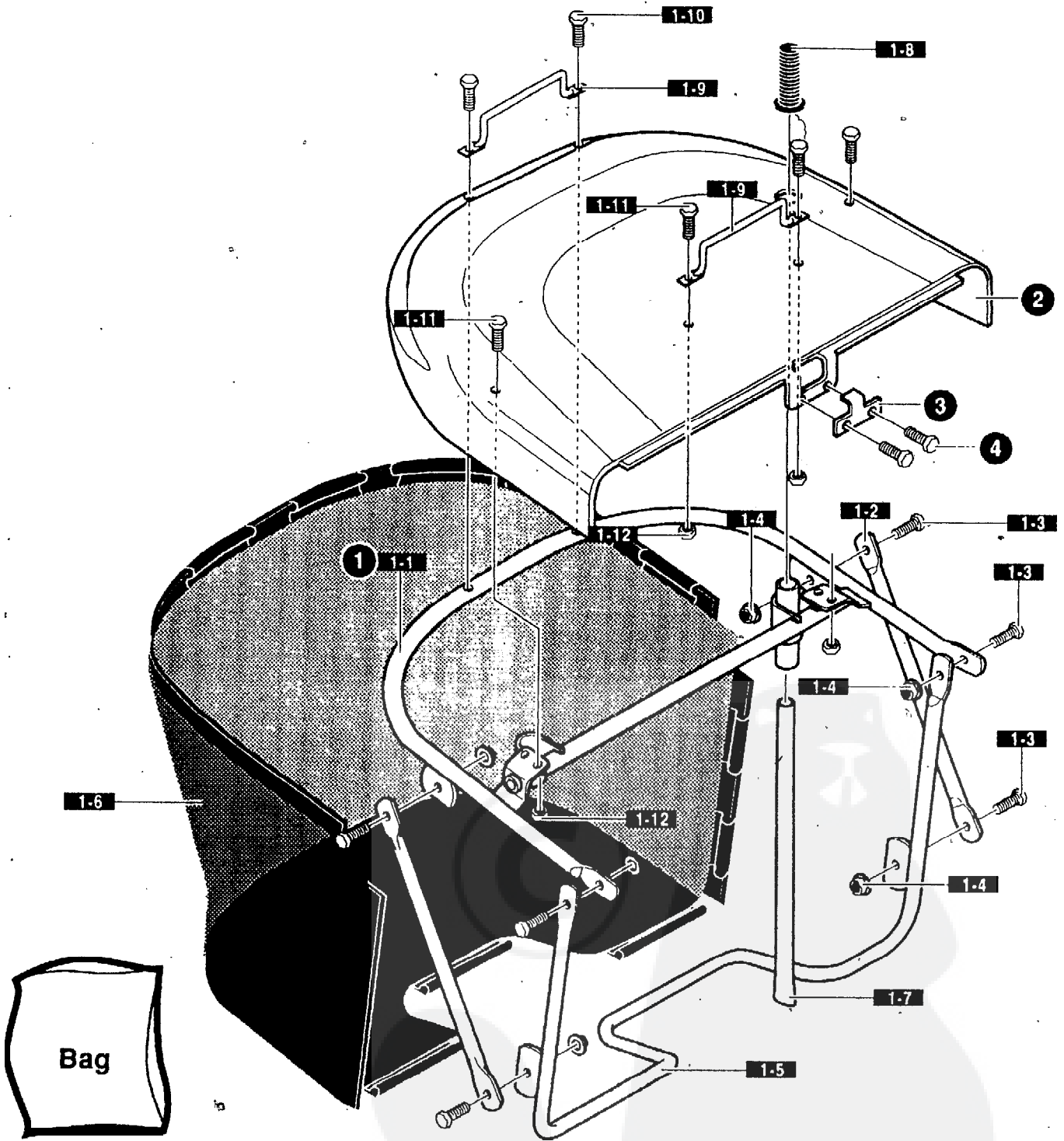

KEY NO.	PART NO.	DESCRIPTION	QTY
1	94560	ASM.G3ASS COLLECTOR REBA	1
1-1	94849	ASSY., UPPER FRAME	1
1-2	94850	BRACE, FRAME COLLECTOR	2
1-3	180020	SCREW, 1/4-20X.75	6
1-4	1502	NUT, 1/4-20 REGHEXCTRLK	6
1-5	94851	ASSY., FRONT FRAME COLLECT	1
1-6	94852	BAG, REBA COLLECTOR	1
1-7	94853	HANDLE, DUMP REBA COLLECT.	1
1-8	94854	RUBBER GRIP 7/8" REBA	1
1-9	94855	HANDLE, REBA COLLECTOR	2
1-10	710266	SCREW, 10-24X.38 SLHWATAP	2
1-11	710266	SCREW, 10-24X.38 SLHWATAP	4
1-12	308459	NUT, #10-24 HXHDNYLK	4
2	94908-860	TOP COVER, COLLECTOR REBA	1
3	94244	BRACKET, SWITCH	1
4		RIVET, POP(NON SERVICEABLE PART)	

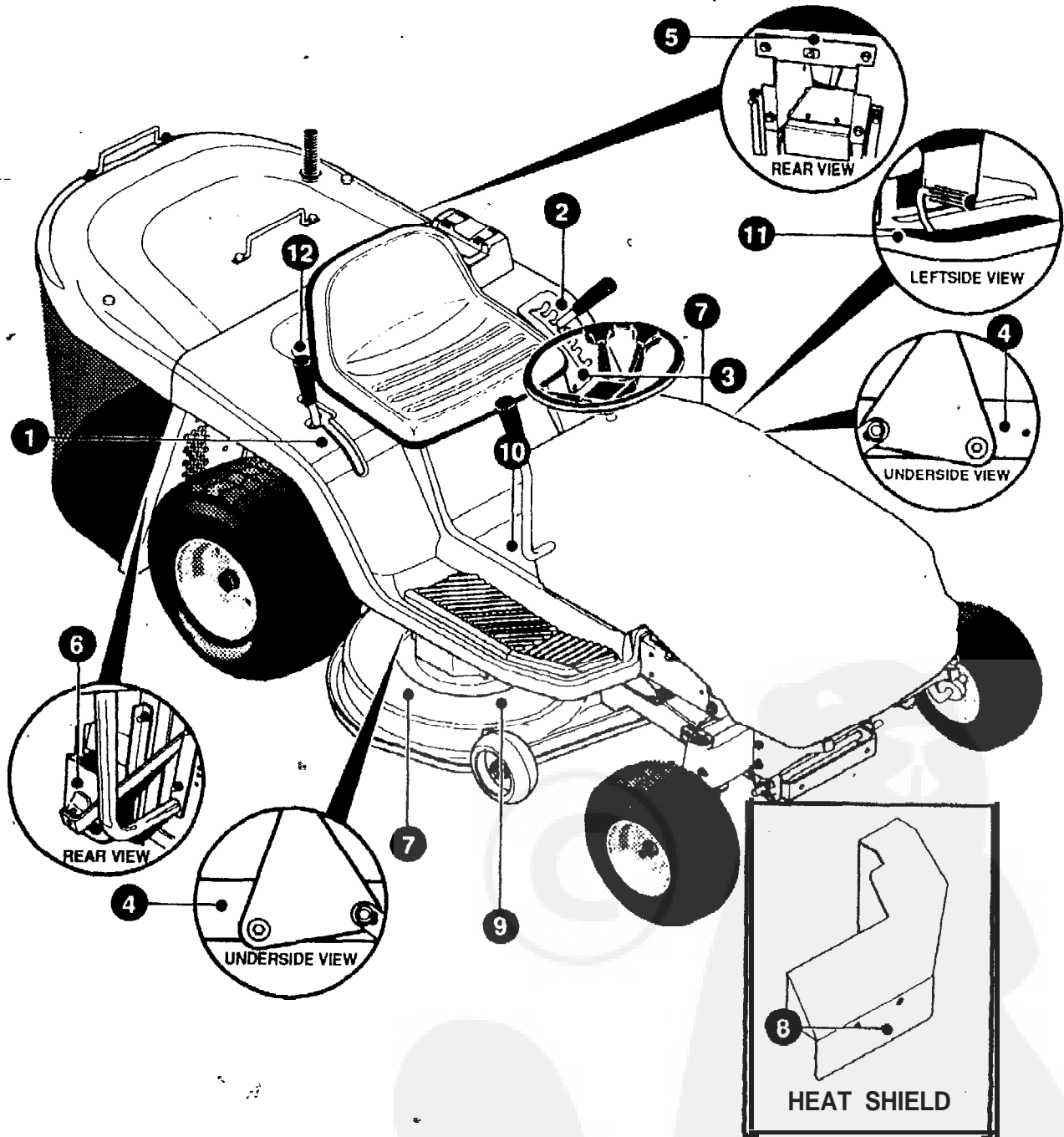

KEY NO.	PART NO.	DESCRIPTION	QTY
1	710558	DECAL, SHIFTER 6-W REBA	1
2	710517	DECAL, HEIGHT ADJUST 6-POS.	1
3	710683	DECAL, DECK LEVEL REBA/NLT EXP	1
4	710523	DECAL, PINCH POINTS WARNING	1
5	33854 1	DECAL,BAGGER "CE" M#44X5939	1
6	338542	DECAL, DRAWBAR WARN M#44X6138	1
7	402700	DECAL, CAUTION DECK LH	2
8	338543	DECAL,HOT SURF WARN M#44X5936	1
9	710684	DECAL, DECK BELT ROUTE REBA	1
10	710534	DECAL,CONS CAUT. M#44X6815	1
11	402702	DECAL,BRAKE/CLUTCH PICTOGRAM	1
12	318010	DECAL,TUV GS MO 44X2929	1

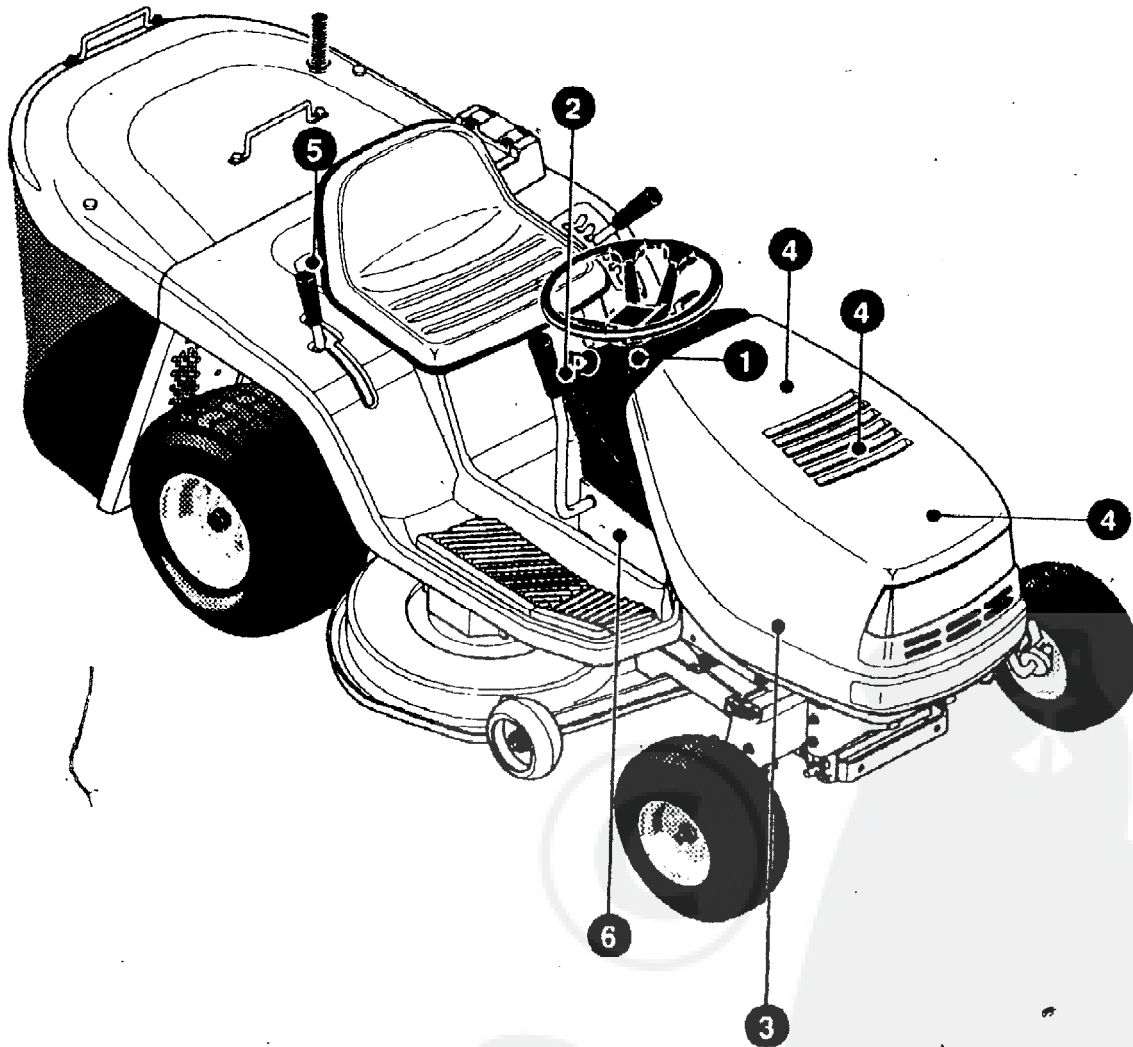

KEY NO.	PART NO.	DESCRIPTION	QTY
1	710615	DECAL, DASH CHOKE-A-MATIC	1
2	710691	DECAL, PARK/BRAKE (P)	1
3	305603	PAD, 18 X 6 FOAM HOOD	2
4	3072 77	PAD, 12 X 4 FOAM HOOD	3
5		NOT A SERVICEABLE PART	
6	710773	DECAL, STD SFT 125/102	2