

REPAIR PARTS MANUAL
18 H.P. LIGHT GROUND ENGAGING TRACTOR
with 42" Mower Deck
MODELS 4218-1300, 4218-1600,
4218-1700 & 4218-1800

WARRANTY

ONE YEAR LIMITED WARRANTY

For one (1) year from date of purchase by the first consumer for residential use (thirty (30) days commercial use), Western International Incorporated warrants that it will replace free of charge, including labor, any original part of any Western International Incorporated product found to be defective by any authorized Service Dealer or the factory, except the battery which is warranted for ninety (90) days from date of purchase.

This warranty does not cover engine, transmission, transaxle or differential (these items are covered by their manufacturer's own warranty). This warranty does not cover parts that have failed due to normal wear or parts that have failed subject to misuse or abuse. Transportation of the unit or part to and from an authorized Service Dealer or the factory is the responsibility of the owner.

A step by step explanation as to what procedure should be followed for this Warranty is:

1. If a part becomes defective, contact the store where the unit was purchased for the name and address of the authorized Service Dealer nearest to you.
2. If you cannot locate an authorized Service Dealer, write Service Department of Western International Incorporated for the name and address of the authorized Service Dealer in your area or call the Service Department at 1-800-247-7464 (outside Iowa), 1-515-265-3461 (Iowa).
3. Return the defective product, along with proof of purchase to such authorized Service Dealer for replacement of any defective part where covered by this warranty.

There is no other express warranty. Implied warranties, including those of merchantability and fitness for a particular purpose are limited to one (1) year from date of purchase. Liability for incidental or consequential damages are excluded.

Some states do not allow limitations on how long an implied warranty lasts, so the above limitation may not apply to you. Some states do not allow the exclusion of incidental or consequential damages, so the above exclusion may not apply to you. This warranty gives you specific legal rights, and you may have other rights which vary from state to state.

Western International Incorporated **P.O. Box 377** **Des Moines, Iowa 50302**

UNIT PARTS AND SERVICE

This manual contains repair parts information and instructions for safety. Read the operator's manual carefully and completely so that you will know proper assembly, use and care of your unit. Fill in and mail the registration card packed with the unit. For service other than covered in operator's manual, contact an authorized service dealer. A nationwide parts and service organization has been established to provide locally available parts and service. A list of authorized parts distributors has been included in this manual. When ordering repair parts, always give the following information: 1. The Part Name; 2. The Part Number; 3. The Quantity desired; 4. The Full (eight digit) Model Number of the unit. The model number will be found on a plate attached to the unit.



Look for this symbol. It means - ATTENTION! BECOME ALERT! A HAZARD TO OPERATOR, BYSTANDERS, PROPERTY OR EQUIPMENT MAY EXIST.

WESTERN INTERNATIONAL INCORPORATED
P.O. BOX 377
DES MOINES, IOWA 50302

Part No. 62839

5085

Price \$2.00

Printed in U.S.A.



OPERATIONAL PRECAUTIONS

THESE INSTRUCTIONS ARE FOR YOUR PROTECTION. PLEASE READ THEM CAREFULLY.



1. Know the controls and how to stop quickly. READ THIS OPERATOR'S MANUAL and instructions furnished with attachments.
2. Wear safety glasses or eye shields when assembling or operating riding mower.
3. Do not allow children to operate the machine. Do not allow adults to operate it without proper instruction.
4. Do not carry passengers. Do not mow when children and others are around. Disengage power to blade(s) or attachment(s) and stop the engine while others are in the vicinity of the mower.
5. Battery fluid (electrolyte) is an ACID and is extremely dangerous. Do not smoke while servicing the battery. Do not service battery near an open flame or spark.
6. Handle gasoline with care, it is highly flammable.
 - A. Use approved gasoline container.
 - B. Never remove the fuel cap of, or add gasoline to, a running or hot engine, or an engine that has not been allowed to cool for several minutes after running. Never fill the tank indoors and always clean up spilled gasoline immediately.
 - C. Do not smoke while filling fuel tank.
 - D. Do not run the engine indoors. Open doors if engine must be run in garage. Exhaust fumes contain CARBON MONOXIDE, an ODORLESS and DEADLY GAS.
7. Check fuel supply before each use allowing space for expansion as the heat of the engine and/or sun can cause gasoline to expand.
8. Do not operate mower when barefooted. Always wear substantial footwear, preferably steel-toed shoes. Do not wear loose fitting clothing that could get caught in moving parts.
9. Clear the work area of objects (wire, rocks, etc.) which might be picked up and thrown. Check all controls for proper function.
10. Disengage all attachment clutches, shift to neutral, and set parking brake before attempting to start the engine (motor). When starting engine equipped with a pull starter, stand firm and make sure your feet are well away from the blade(s).
11. Disengage power to blade(s) or other attachment(s) and stop the engine (motor) before leaving the operator's position. Always dismount from left side.
12. Disengage power to blade(s) or other attachment(s) and stop the engine (motor) before making any repairs or adjustments.
13. Disengage power to blade(s) or other attachment(s) when transporting or not in use.
14. Take all possible precautions when leaving the vehicle unattended, such as disengaging power to blade(s) or attachment(s), lower the attachment(s), setting the parking brake, stopping the engine (motor), and removing the key.
15. Do not stop or start suddenly when going uphill or downhill. Mow up and down the face of steep slopes; never across the face.
16. Reduce speed and exercise extreme caution on slopes and in sharp turns to prevent tipping or loss of control. Be especially cautious when changing direction on slopes.
17. Stay alert for holes, rocks, and roots in the terrain and other hidden hazards. Keep away from drop-offs. Never operate your riding mower on wet or slippery grass or at a speed which could cause a skid. Exercise care when mowing around a fixed object to prevent the blade(s) from striking it. Never deliberately run over any foreign object.
18. Always disengage blade control lever before attempting to remove the mower from a hole or other obstruction.
19. Use care when pulling loads or using heavy equipment.
 - A. Use only approved drawbar hitch points.
 - B. Limit loads to those you can safely control.
 - C. Do not turn sharply. Use care when backing.
 - D. Use counterweight(s), wheel weights or tire chains when suggested in attachment(s) instructions.
20. Watch for traffic when crossing or near roadways.
21. When using attachment(s), never direct discharge of material toward bystanders nor allow anyone near the vehicle while in operation.
22. Keep the vehicle and attachments in good operating condition, and keep safety devices in place and in working condition.
23. Keep all nuts, bolts, and screws tight to be sure the equipment is in safe working condition.
24. Never store the equipment with gasoline in the tank inside a building where fumes may reach an open flame or spark. Allow the engine to cool before storing in any enclosure.
25. To reduce fire hazard, keep the engine free of grass, leaves, or excessive grease.
26. The vehicle and attachments should be stopped and inspected for damage after striking a foreign object, and the damage should be repaired before restarting and operating the equipment.
27. Do not change the engine governor settings or overspeed engine.
28. When using the vehicle with mower, proceed as follows:
 - A. Mow only in daylight or in good artificial light.
 - B. Never make a cutting height adjustment while the engine (motor) is running if the operator must dismount to do so.
 - C. Shut the engine (motor) off when removing the grass catcher or unclogging chute.
 - D. Check the blade mounting bolts for proper tightness at frequent intervals.
29. Under normal usage, the grass catcher bag material is subject to deterioration and wear. Check bag frequently for deterioration and wear and replace worn bags. Check that replacement bags comply with the original manufacturer's recommendations or specifications.
30. Disengage power to mower before backing up. Do not mow in reverse unless absolutely necessary and then only after careful observation of the entire area behind the mower.

MODELS 4218-1300, 4218-1600, 4218-1700 & 4218-1800

ALWAYS GIVE THE FOLLOWING INFORMATION WHEN ORDERING REPAIR PARTS:
 1. The PART NUMBER; 2. The PART NAME; 3. QUANTITY DESIRED; 4. The MODEL NUMBER (As shown on Model Plate)
 SEND PART ORDERS AS PER INSTRUCTIONS ON THE FRONT PAGE
 YOUR UNIT IS RIGHT HAND (RH) OR LEFT HAND (LH) AS YOU STAND BEHIND IT.
 DO NOT USE KEY NUMBERS WHEN ORDERING REPAIR PARTS, ALWAYS USE PART NUMBERS.
 All replacement parts will be supplied in current production colors or in a neutral color.
 A handling fee is applicable to small parts orders.

Key No.	Part No.	Description	Key No.	Part No.	Description
1	456836	Roll Pin, ¼ x 2¼ In.	30	41108	Tire, Front
2	55633	Steering Wheel	31	120369	*Nut, Hex ¾-24 Thd.
3	454565	Roll Pin, ¼ x 1¼ In.	32	120382	*Lockwasher, Split, ¾ In.
4	53228	Shaft, Steering Wheel	33	48764	Tie Rod
5	52428	Pinion	34	55544	Front Spindle Assy., R.H.
6	52405	Bushing	35	42815	Flatwasher
7	180177	*Screw, Hex Hd, ½-13 x 1½ In.	36	52403	Bolt, Front Axle Pivot
8	52406	Eccentric, Steering Adjust	37	35498	Screw, Hex, Wa. Hd, 5/16-18 x ¾ In
9	52382	Sector Gear	38	120638	Lockwasher, Split, 5/16 In.
10	22265	Washer	39	52648	Bracket, Stabilizer
11	9414074	Locknut, ½-13 Thd.	40	122007	*Screw, Hex Hd, 5/16-18 x ¾ In.
12	36625	"E" Ring	41	Transaxle	†Peerless, 5 Speed, Model 801
13	21682	Flatwasher, ¾ In.	42	39628	Key
14	21970	Flatwasher, 1 In.	43	122083	*Screw, hex Hd, 5/16-18 x 2¾ In.
15	52376	Drag Link Assembly	44	120386	Flatwasher, 3/16 In.
16	124925	Nut, Hex Jam, ¾-24 Thd.	45	29386	Shoulder Bolt
17	21275	Ball Joint Assembly	46	56447	Spacer
18	55727	Bracket, Deck Hanger	47	9413447	Locknut, Hex, 5/16-18 Thd.
19	68026	Decal, Deck Hanger, R.H.	48	271184	*Nut, Keps, 5/16-18 Thd.
20	68027	Decal, Deck Hanger, L.H.	49	52398	Bracket, Brake
21	40394	Hub Cap	50	55893	Tire, Rear
22	52407	Bearing, Front Spindle	51	56356	Wheel Assembly, Rear
23	55730	Front Axle Assembly	52	45602	Washer
24	55543	Front Spindle Assembly, L.H.	53	9413534	Locknut, ¾-16 Thd.
25	53373	Cover, Axle End	54	996307	Flatwasher
26	642	Flatwasher	55	122207	*Screw, Hex Hd, ¾-16 x 3 In.
27	39979	Bearing	56	2483	Spring Washer
28	24167	Valve Stem	57	62863	Operator's Manual (Not Illustrated)
29	39829	Wheel w/Bearing	58	62839	Parts Manual (Not Illustrated)

*Standard Hardware Items - May Be Purchased Locally.

†Contact Tecumseh/Peerless authorized service dealer for parts and warranty.

MODELS 4218-1300, 4218-1600, 4218-1700 & 4218-1800

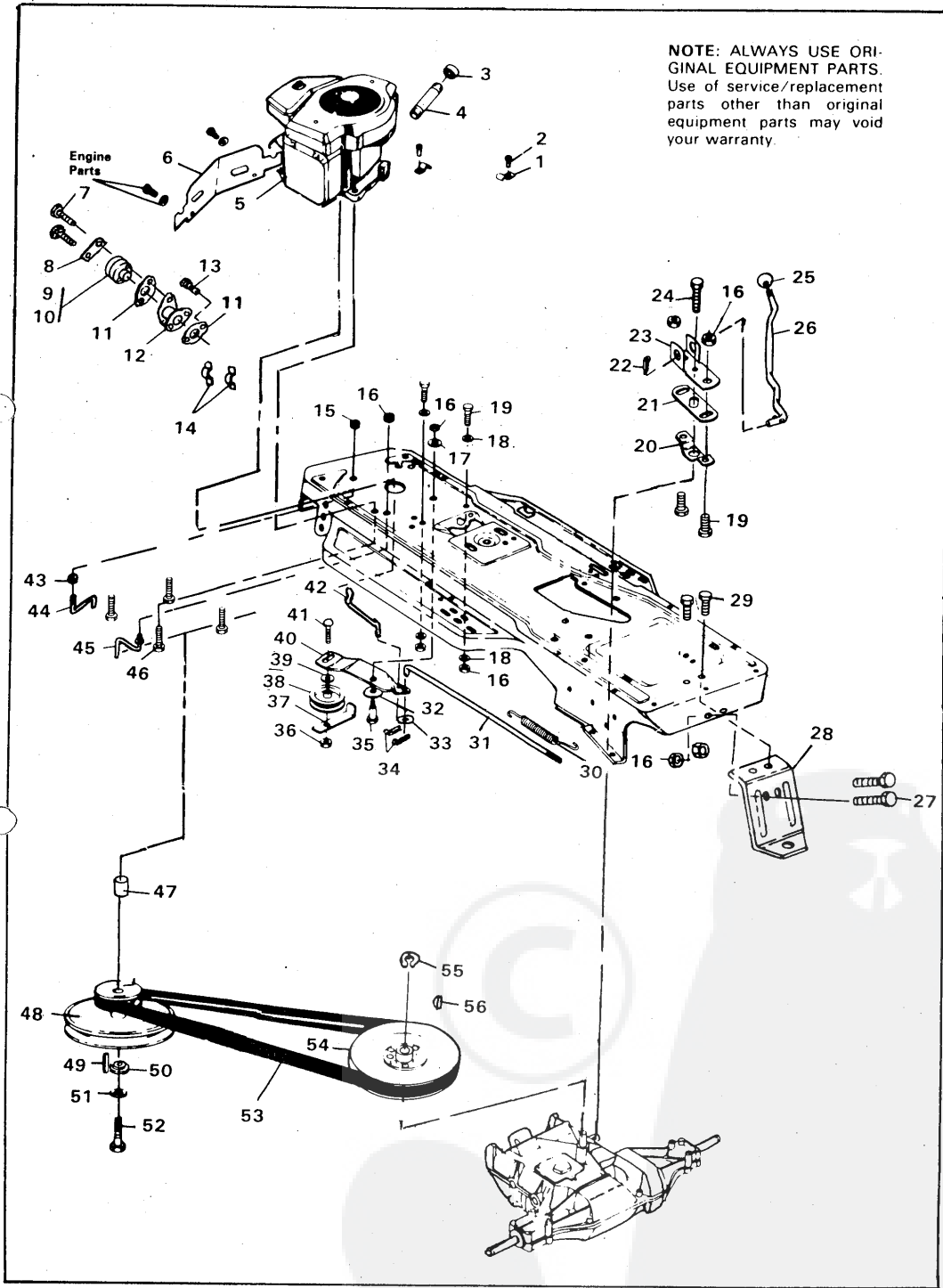

MODELS 4218-1300, 4218-1600, 4218-1700 & 4218-1800

Key No.	Part No.	Description	Key No.	Part No.	Description
1	56538	Wire-Retainer	29	48148	Screw, Taptite, 3/16-16 x 1 In.
2	35258	Screw, Taptite, No. 10-24 x 3/8 In.	30	56359	Spring, Clutch
3	47828	Cap, Oil Drain Tube	31	52395	Brake Rod
4	52404	Tube, Oil Drain	32	4107	Washer
5	Engine	§See Footnote Below	33	120386	*Flatwasher, 5/16 In.
6	52796	Bulkhead, Hood	34	121222	Cotter Pin, 3/32 x 3/4 In.
7	173063	Screw, Hex Hd, 5/16-18 x 3 1/2 In.	35	41890	Shoulder Bolt
8		Engine Part	36	9413534	Locknut, Hex, 3/8-16 Thd.
9	56539	Muffler, L.H.	37	39659	Belt Retainer
10	55540	Muffler, R.H.	38	35374	Pulley, Idler
11		Gasket, Muffler (Engine Part)	39	274517	*Flatwasher, 3/8 In.
12	56615	Bracket, Muffler Assy.	40	52411	Idler Arm
13	186923	Screw, Hex Soc., 1/4-20 x 5/8 In.	41	45892	Carriage Bolt, 3/8-16 x 1 1/2 In.
14	41482	Press Clip	42	52402	Rod Clutch
15	41529	Jam Nut, 3/8-17 Thd.	43	120377	Nut, Hex
16	9413447	Locknut, Hex, 5/16-18 Thd.	44	53955	Belt Guide
17	45602	Washer, 5/16 In.	45	52401	Belt Guide
18	120393	*Flatwasher, 5/16 In.	46	50947	Screw, Taptite, 5/16-18 x 1 1/4 In.
19	120229	*Screw, Hex Hd, 5/16-18 x 7/8 In.	47	56430	Spacer, Engine Pulley
20	54685	Bracket, Shift, Lower	48	56434	Pulley, Engine
21	55516	Bracket, Shift Adjusting	49	56432	Key, 1/4 x 1/4 x 4 1/4 In.
22	137185	Cotter Pin	50	56431	Washer, Pilot
23	55517	Bracket, Shift	51	120383	Lockwasher, Split, 7/16 In.
24	56255	Screw, Nylock, 1/4-28 x 3/4 In.	52	187612	Screw, Hex Hd., 7/16-20 x 4 1/2 In.
25	55514	Knob, Shift Lever	53	39454	V-Belt
26	56541	Shift Lever	54	54692	Pulley, Input
27	120228	Screw, Hex Hd, 5/16-18 x 5/8 In.	55	22053	Retaining Ring
28	52647	Hitch	56	3021	Key, Woodruff, No. 606

MODELS 4218-1300, 4218-1600, 4218-1700 & 4218-1800

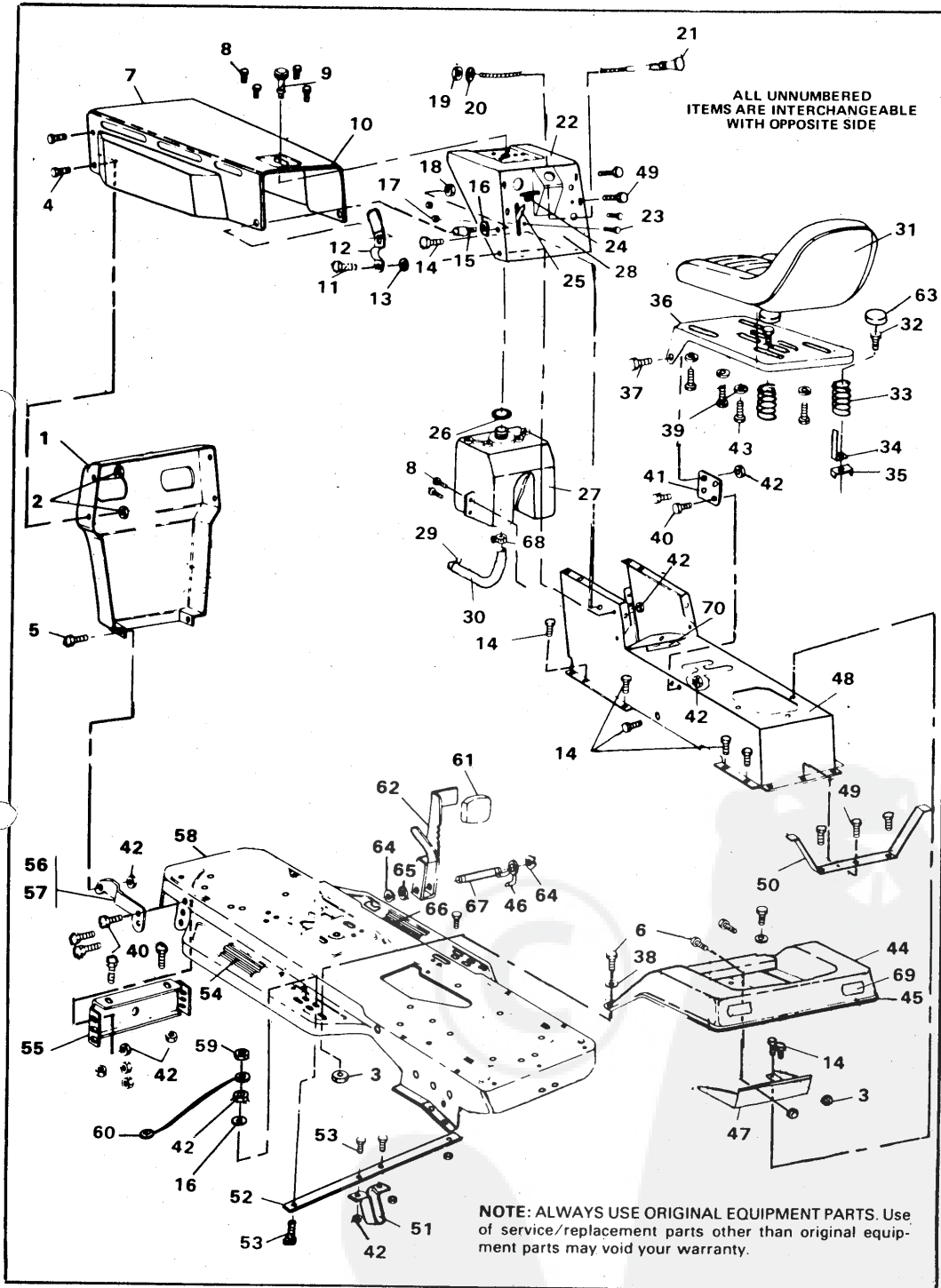

MODELS 4218-1300, 4218-1600, 4218-1700 & 4218-1800

Key No.	Part No.	Description	Key No.	Part No.	Description
1	52651	Grill	35	53744	Clip, Seat Spring
2	50352	Locknut, Flange, ¼-20 Thd.	36	56196	Mounting Bracket, Seat
3	9424215	Locknut, Hex, ¼-20 Thd.	37	20507	Shoulder Bolt
4	274672	Screw, Hex Hd, ¼-20 x ¾ In.	38	120386	*Flatwasher, 5/16 In.
5	36149	Shoulder Bolt	39	120638	*Lockwasher, Split, 5/16 In.
6	48900	Screw, Hex Wa. Hd, ¼-20 x 1 In.	40	120228	*Screw, Hex Hd, 5/16-18 x ¾ In.
7	52661	Hood Assembly	41	53746	Support
8	49050	Screw, Plastite, ¼-10 x ¾ In.	42	9413447	Locknut, Hex, 5/16-18 Thd.
9	56183	Gas Gauge	43	120834	*Screw, Hex Hd, 5/16-18 x ½ In.
10	56304	Edging, Hood	44	51083	Fender Assembly
11	8482	Shoulder Bolt	45	55023	Trim, Fender
12	55020	Latch, Hood	46	54807	Spring, Return
13	120394	*Flatwasher, ¾ In.	47	52436	Bracket, Fender
14	995346	*Screw, Taptite, ¼-20 x ½ In.	48	55736	Console
15	53446	Pin, Hood Latch	49	995338	*Screw, Hex Hd, ¼-20 x ¾ In.
16	138538	Washer, Internal Tooth, 5/16 In.	50	52897	Brace, Fender Support
17	271166	*Nut, Keps, No. 10-24 Thd.	51	49777	Guide, Rear, Mower Deck
18	45174	Locknut, Wide Fl., 5/16-18 THd.	52	43964	Guide Support, Rear
19	124925	*Jam Nut, ¾-24 Thd.	53	122017	*Screw, Hex Hd, 5/16-18 x 1 In.
20	138489	Washer, Shakeproof, ¾ In.	54	55947	Foot Pad, L.H.
21	52086	Cable, Choke	55	56361	Bracket, Axle Support, Front
22	56045	Dash Assembly	56	56257	Bracket, Grille, L.H.
23	35291	Screw, Hex Hd, No. 10-24 x ½ In.	57	56258	Bracket, Grille, R.H.
24	39486	Knob, Throttle Control	58	56358	Main Frame
25	52085	Throttle Control	59	271184	*Nut, Keps, 5/16-18 Thd.
26	54885	Pad, Fuel Tank	60	55511	Ground Wire
27	52536	Tank, Fuel	61	48160	Rubber Pad, Pedal
28	70313	Decal, Dash	62	52575	Brake Pedal Assembly
29	41008	Clamp, Fuel Line	63	53205	Cover, Seat Spring
30	51211	Tubing, Fuel Line	64	20864	Retaining Ring
31	52272	Seat	65	54806	Spacer
32	44811	Screw, Taptite, ¼-20 x ¾ In.	66	55946	Foot Pad, R.H.
33	49335	Spring, Seat	67	54808	Rod, Brake-Clutch
34	53745	Stop, Seat	68	47345	Clamp, Fuel Line
			69	43525	Reflector (4218-1800 only)
			70	70117	Decal, Caution

*Standard Hardware Items - May Be Purchased Locally.

MODELS 4218-1300, 4218-1600, 4218-1700 & 4218-1800

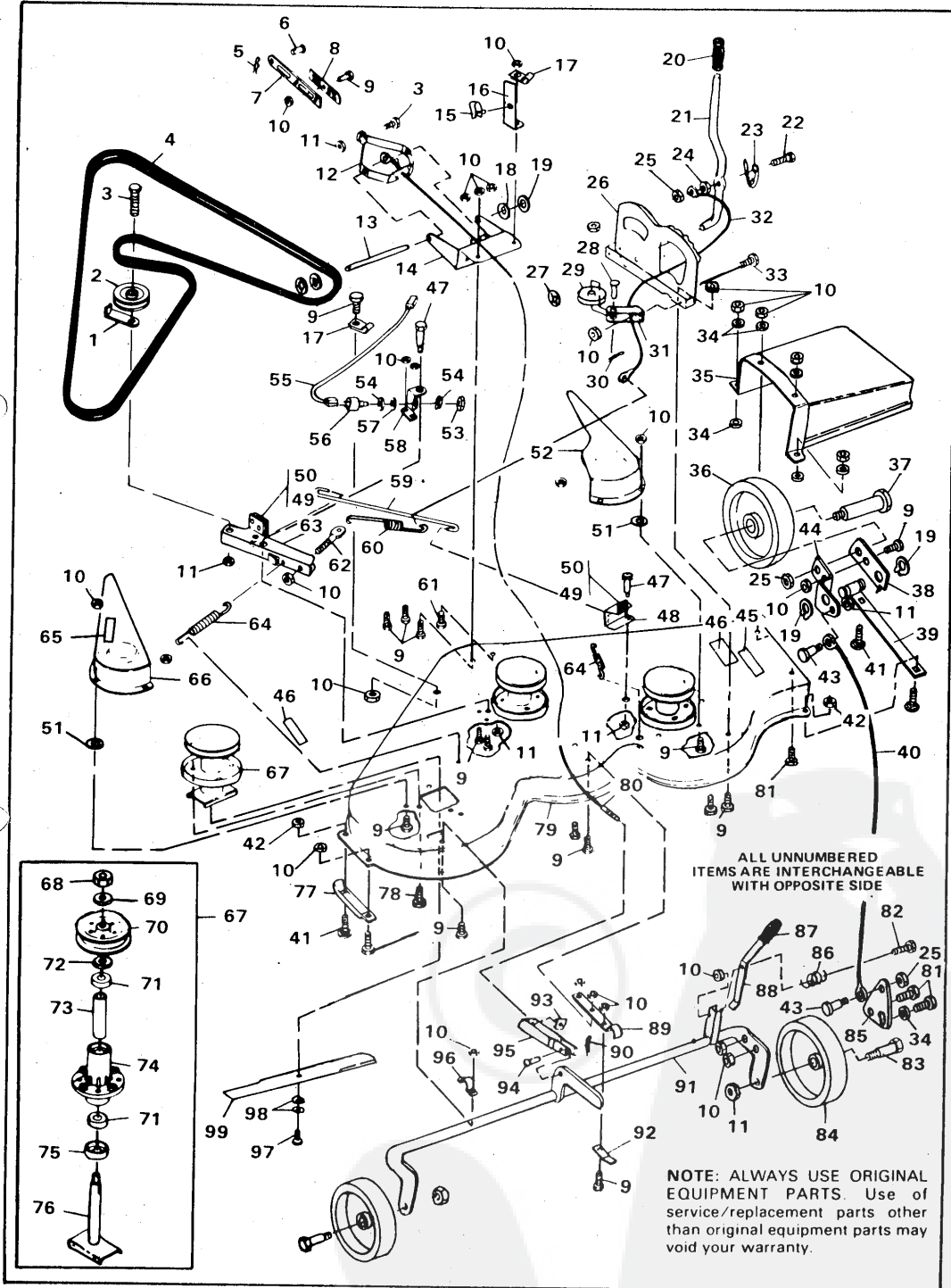

MODELS 4218-1300, 4218-1600, 4218-1700 & 4218-1800

Key No.	Part No.	Description	Key No.	Part No.	Description
1	49318	Belt Retainer	51	120393	*Flatwasher, 5/16 In.
2	51134	Pulley, Idler	52	52912	Belt Guard, R.H.
3	120918	*Screw, Hex Hd, 5/16 x 1 1/2 In.	53	56635	Nut, Hex
4	49330	V-Belt	54	45877	Nut, Switch
5	56180	Hair Pin Cotter	55	48851	Wire Assembly
6	47816	Pin, Clevis, Short	56	41204	Switch
7	49059	Bar Hitch, Straight	57	45878	Washer, Switch
8	49058	Bracket, Lock	58	47517	Bracket, Idler Arm
9	120228	*Screw, Hex Hd, 5/16-18 x 5/8 In.	59	50683	Brake Rod
10	9413447	Locknut, 5/16-18 Thd.	60	49331	Spring, Clutch
11	9413534	Locknut, 5/16 Thd.	61	122017	*Screw, hex Hd, 5/16-18 x 1 In.
12	50613	Bracket, Pivot	62	51183	eyebolt, 5/16-18 Thd.
13	55724	Pin, Pivot	63	52112	Clutch-Brake Arm Assembly
14	48676	Lift Support Plate	64	35410	Spring
15	54888	Retainer, Wire	65	68249	Decal, No Step
16	56588	Bracket, Up-Stop	66	52911	Belt Guard, L.H.
17	56546	Retainer, Wire	67	56283	Quill Assembly
18	996425	Flatwasher, 1/2 In.	68	51445	Locknut, Flange, 7/16-20 Thd.
19	20864	Retaining Ring	69	56365	Flatwasher
20	46478	Hand Grip	70	56391	Pulley, Quill
21	53694	Clutch Lever	71	49562	Bearing
22	53901	Screw, Hex Hd, Spec., 1/4-20 x 1 1/2 In.	72	56280	Spacer
23	46561	Spring, Clutch Lever.	73	50818	Spacer Tube
24	271172	*Keps Nut, 1/4-20 Thd.	74	55547	Quill Casting
25	9424215	Locknut, 1/4-20 Thd.	75	50616	Dust Shield
26	53248	Quadrant	76	56623	Saddle & Shaft Assembly
27	53697	Push Nut	77	49321	Skid, L.H.
28	49332	Pin, 3/8 x 1 In.	78	50634	Screw, Hex Wa. Hd, Tap, 5/16-18 x 7/8 In.
29	39298	Pulley, Nylon	79	53896	Mower Deck
30	121222	*Cotter Pin, 3/32 x 3/4 In.	80	55880	Lift Cable
31	49320	Support, Cable Pulley	81	122007	*Screw, Hex Hd, 5/16-18 x 3/4 In.
32	49326	Clutch Cable	82	120696	*Screw, Hex Hd, 5/16-18 x 2 1/4 In.
33	122052	*Screw, Hex Hd, 5/16-18 x 1 3/4 In.	83	23763	Axle, Deck Wheel
34	120386	*Flatwasher, 5/16 In.	84	52584	Wheel
35	49574	Chute, Discharge	85	56377	Bracket, Adjust
36	56386	Wheel, Deck	86	53246	Spring, Height Adjust Lever
37	56380	Wheel Axle	87	20250	Hand, Grip, Height Adjust Lever
38	56628	Bracket, Arm	88	50027	Lever, Height Adjust
39	56626	Skid, R.H.	89	49322	Brace, Pivot Tube
40	56381	Cable	90	8260	Hairpin Cotter
41	120230	*Carriage Bolt, 5/16-18 x 1 1/4 In.	91	56387	Pivot Tube Assembly
42	271184	*Keps Nut, 5/16-18 Thd.	92	50092	Angle Bracket
43	56611	Shoulder Bolt	93	120372	Nut, Square, 1/4-20 Thd.
44	56627	Bracket, Arm Crank	94	39522	Pin, Clevis
45	70152	Decal, Height Adjust	95	39404	Clevis, Lift Cable
46	68547	Decal, Caution	96	42424	Support, Pivot Tube
47	47516	Shoulder Bolt	97	39573	Screw, Hex Hd, 3/8-24 x 1 In.
48	49316	Brake Lever Assy. (Incl. Items 49 & 50)	98	2483	Formed Washer
49	41601	Rivet	99	56370	Blade, 1 1/2 In.
50	41471	Pad, Brake			

*Standard Hardware Items - May Be Purchased Locally.

MODELS 4218-1300, 4218-1600, 4218-1700 & 4218-1800

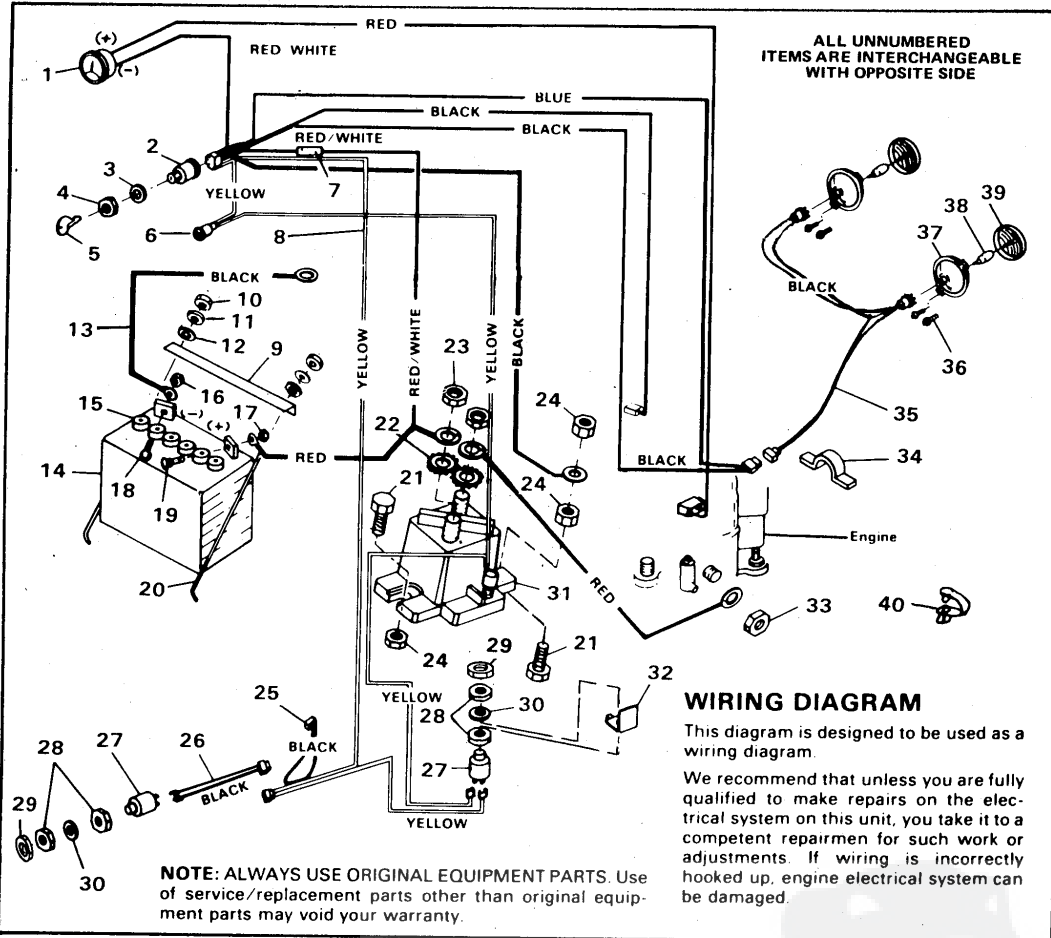

Key No.	Part No.	Description
1	39463	Ammeter
2	52583	Switch, Ignition w/Keys
3	138557	Lockwasher (Switch Part)
4	48140	Locknut (Switch Part)
5	49643	Key, Ignition
6	45333	Indicator Light
7	49211	Fuse
8	56774	Wire Harness Assembly
9	56360	Bracket, Battery, Hold-Down
10	120375	*Nut, Hex, 1/4-20 Thd.
11	120380	Lockwasher, Split
12	120392	Flatwasher, 1/4 In.
13	55511	Ground Wire
14	52936	Battery
15	40892	Cap, Battery
16	271172	*Nut, Keps, 1/4-20 Thd.
17	271184	*Nut, Keps, 5/16-18 Thd.
18	126203	*Carriage Bolt, 1/4-20 x 3/8 In.
19	126216	*Carriage Bolt, 5/16-18 x 3/4 In.
20	40234	Battery Rod

Key No.	Part No.	Description
21	187745	*Screw, Hex Hd, 1/4-20 x 3/4 In.
22	138485	*Washer, Ext., Shakeproof, 5/16 In.
23	120368	*Nut, Hex, 5/16-24 Thd.
24	9424215	Locknut, Hex, 1/4-20 Thd.
25	42071	Wire Assembly, By-Pass
26	48851	Wire Assembly, Deck Switch
27	41204	Switch, Lockout
28	45877	Nut (Lockout Switch Part0
29	56635	Nut, Hex
30	45878	Lockwasher (Lockout Switch Part)
31	53716	Solenoid
32	49734	Bracket, Switch Mounting
33		Engine Part
34	41482	Wire Clip, Press
35	56189	Lead Wire, Headlight
36	50668	Screw, Hex Wa. Hd, No. 10-14 x 1/2 In.
37	52571	Bezel, Headlight
38	52570	Lens, Headlight
39	52572	Bulb, Headlight
40	54888	Retainer, Wire

*Standard Hardware Items - May Be Purchased Locally.

ACCESSORIES

Contact dealer where tractor was purchased for available accessories or attachments. If unable to contact dealer, write to address on front cover of this manual.

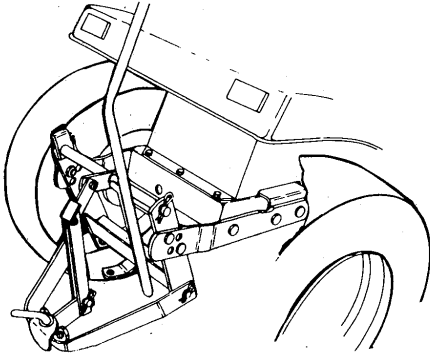

HEAVY DUTY HITCH

Includes lift bar mechanism. Heavy duty hitch is required when using attachments shown with asterisk (*).

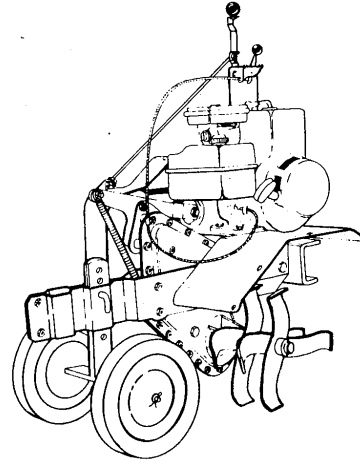

*28" - 5 H.P. MOTORIZED REAR MOUNTED TILLER

Heavy duty chain drive with no. 50 chain, 5 H.P. B & S horizontal shaft engine, 14 inch slasher type tines. Adjustable tilling depth. 10 inch steel wheels. Clutch and throttle operated from drivers seat. Moves and tills under its own power. Heavy duty hitch required.

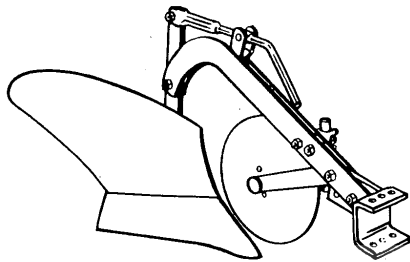

**10" PLOW

Plowing depth is adjustable up to 6 inches without leaving drivers seat. Plows up to a 10 inch furrow, and is equipped with a free-swinging 11 inch rolling coulters for cutting sod. A single pin connects plow to heavy duty hitch. Heavy duty hitch required; wheel weights recommended.

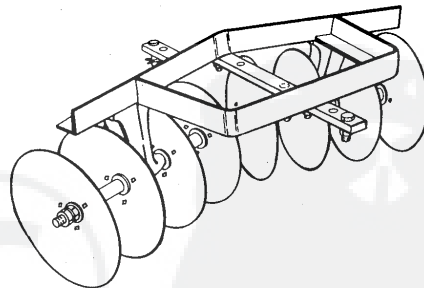

*DISC HARROW

Eight 11 inch diameter steel disc blades can be adjusted for a discing width from 29 to 39 inches. Individual gangs have a position angle adjustment of 10, 15 & 20 degrees. J-bolt holds standard 16 inch concrete block for added discing weight. Heavy duty hitch required.

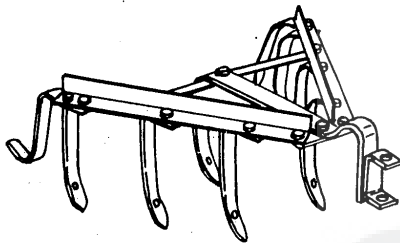

*CULTIVATOR

Cultivator has 7 forged high-carbon steel shanks bolted in place. Ideal for working a variety of crops, letting you straddle rows or work between them. Adjusts from 6 to 42 inches. Convenient leveling and depth adjustment at the hitch end. Single pin connects cultivator to heavy duty hitch.

FRONT WHEEL WEIGHTS

One pair, 20 pounds each. Total weight 40 pounds. Includes mounting hardware.

REAR WHEEL WEIGHTS

One pair, 50 pounds each. Total weight 100 pounds. Includes mounting hardware.

DETAILED MOUNTING AND OPERATING INSTRUCTIONS ARE INCLUDED WITH EACH ACCESSORY.

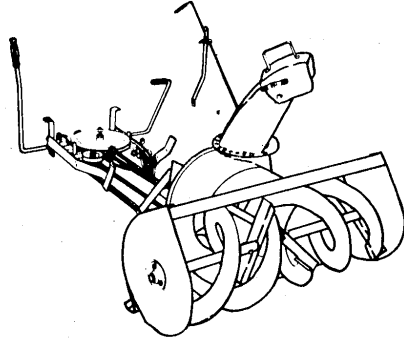

†TWO STAGE SNOW THROWER

A powerful two stage snow thrower with a 14 inch second stage impeller capable of moving more than 70 tons of snow per hour and throwing it accurately in any direction you choose. Driver controlled discharge chute turns a 160° arc. Wheel weights and tire chains recommended.

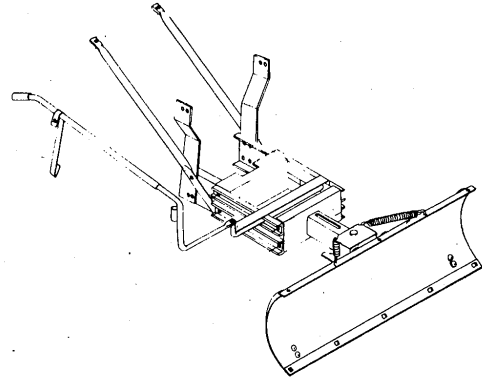

†42" SNOW & GRADER BLADE

Rugged, heavy gauge steel blade. Spring loaded blade glides over uneven surfaces. Can be adjusted from seat for straight position, or 35° left or right. Locks in raised position for traveling. Wheel weights and tire chains recommended.

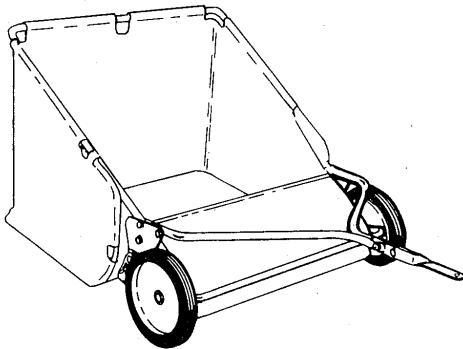

LAWN SWEEPER

Features extra heavy duty wheels and heavy duty basket. Basket is water, shrink and mildew proof with big 6 bushel capacity. Dump release and height adjustor can both be operated from drivers seat.

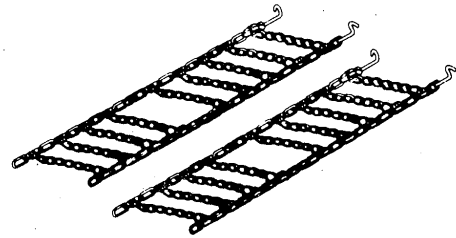

TIRE CHAINS

Tire chains for added traction are available. Fits 23 x 9.50 tires. Specify tire size when ordering for different size tire.

(*) Heavy Duty Hitch Required
() Heavy Duty Hitch Required; Wheel Weights Recommended**
(†) Wheel Weights & Tire Chains Recommended

SEE, CALL OR WRITE ONE OF THE FOLLOWING DISTRIBUTORS FOR PARTS FOR: HOMKO - LAWN SCOUT - AMF - TURFMASTER - DYNAMARK - OR ANY OTHER WESTERN INTERNATIONAL INCORPORATED PRODUCT.

ALABAMA

Automotive Elect. Service, 415 Meridian St., Huntsville, AL 35801, (205) 539-2131, AL WATS 800-536-3394 *b,c,f,g,h
Warlick-Miller A/C Eng., 630 N. 20th St., Bessemer, AL 35020, (205) 424-8288, AL WATS 800-292-8123
MS WATS 800-292-4494 *b,c,f,g,h

CALIFORNIA

Billiou's, 75 No. D, Porterville, CA 93257, (209) 784-4102 *b,c,f,g,h
The Lawn Mower Shop, 1340 El Camino Real, San Carlos, CA 94070, (415) 593-4716 *a,d,f,g

COLORADO

Spitzer Ind. Prod. Co., 6601 N. Washington, Thornton, CO 80229, (303) 287-3414 *b,d,h

FLORIDA

G. L. O. Products Inc., 13201 Belcher Rd. S., Largo, FL 33543, (813) 530-9723 *a,c,h

Radco Distributors Inc., 4909 Victor St., Box 5459, Jacksonville, FL 322070459, (904) 733-7957 *a,c,f,g,h

ILLINOIS

Cox Tire & Battery, 603 N. Market, Marion, IL 62959, (618) 993-2607
IL WATS 800-642-4351 *a,c,f,g,h
Garmoe Distr. Inc., 2620 N. Mannheim Road, Franklin Park, IL 60131, (312) 455-3588 *a,c,f,g,h
Small Engine Parts, 3515 Auburn St., Rockford, IL 61103, (815) 964-1754 *b,c,f,g,h

INDIANA

Thompson Sales & Service, 2400 W. Ridge Road, Gary, IN 46408, (219) 980-3282 *a,b,c,f,g,h

IOWA

Bruce Engine, 1829 N.W. 86th, Des Moines, IA 50322, (515) 278-5151 *a,c,f,g,h

KANSAS

Colladay Hdw. Co., 201 N. Plum, Box 766, Hutchinson, KS 67501, (316) 663-4477 *a,c

KENTUCKY

Auto-Electric Inc., 715 W. Hwy 80, Box 671, Somerset, KY 42501, (606) 679-1171 *c,f,g,h

Cayce Mill Supply Co., 1st & Douglas St., Hopkinsville, KY 42240, (502) 886-3335 *f,g,i

Ellingsworth Auto Electric, 1003-08 E. Broadway, Louisville, KY 40204 (Serving Southern Indiana), (502) 585-5055, KY WATS (800) 722-5061 *b,c,f,g,h

LOUISIANA

United Engine Service, Inc., 11923 Cloverland Ave., Baton Rouge, LA 70809, (504) 291-2622 *a,d,f,g,h

MARYLAND

Center Supply Co., 6867 New Hampshire Ave., Takoma Park, MD 20912, (301) 270-1690 *b,c,f,g,h

Kunkel Service Co., 6252 Frankford Ave., Baltimore, MD 21206, (301) 377-4008, MD WATS 800-492-8886 *b,c,f,g,h

MASSACHUSETTS

Morton B. Collins Co., 300 Birnie Ave., Box 70058, Springfield, MA 01107, (413) 732-7449 *a,c,g,h

Crandall-Hicks Co., 250 Eliot St., Ashland, MA 01721, (617) 881-6122 *a,d

MICHIGAN

Air Cooled Engine Div., 615 First St., Menominee, MI 49858, (906) 863-8011, MI WATS (906 area only) 800-562-4825 *a,c,f,g,h

Heat Engineering Inc., 7700 Southfield Road, Detroit, MI 48228, (313) 271-7550 *a,c,f,g,h

Lorenz Service Co., 2500 S. Pennsylvania Ave., Lansing, MI 48910, (517) 484-1361 *b,c,f,g,h

MINNESOTA

Northern Automotive Co., 1401 W. Broadway, Minneapolis, MN 55411, (612) 522-6656 *a,c,f,g,h

MISSISSIPPI see Bessemer, Alabama

MISSOURI

Gunther's Service & Supply, 7320 Wornall Road, Kansas City, MO 64114, (816) 523-1952 *a,f,g,h

Wilson Engine & Parts Inc., 4159 Shoreline Drive, Jct. I-70 & 270, Earth City, MO 63045, (314) 739-1313, MO WATS 800-392-4063, WATS (outside MO only) 800-367-2787 *a,b,d,f,g,h

NEW JERSEY

Power Distributors, Inc., 102 Mayfield Ave., Edison, NJ 08837, (201) 225-4922 *i

NEW YORK

Loegler & Ladd Inc., 3950 Broadway, Box 214, Buffalo, NY 14225, (716) 684-0600 *a,c

Stiefvater Distr. Inc., Clinton Road, Route 12B, New Hartford, NY 13413, (315) 853-5581 *a,c,f,g,h

NORTH CAROLINA

Carswell Distr. Co., 3750 N. Liberty St., Box 4193, Winston-Salem, NC 27105, (919) 767-7700 *g,i

Dixie Sales Co., Inc., 335 N. Green, Box 1408, Greensboro, NC 27402, (919) 274-0490, NC WATS 800-632-1276 *b,c,f,g,h

OHIO

Small Engine Distr., 2430 Tremainsville Rd., Box 5815, Toledo, OH 43613, (419) 475-7261 *b,c,f,g,h

Small Engine Distr., 5250 N. Dixie, Box 1481, Dayton, OH 45414, (513) 278-8241 *b,f,g,h

OKLAHOMA

Albro's, 2921 W. Hefner Rd., Oklahoma City, OK 73120, (405) 751-1711 *a,c,f,g,h

PENNSYLVANIA

Bluemont Co., 11101 Frankstown Road, Pittsburg, PA 15235, (412) 242-2522 *a,b,c,f,g,h

Scranton Auto Ignition, 1133 Wyoming Ave., Scranton, PA 18509, (717) 342-8133 *b,c,f,g,h

SOUTH CAROLINA

Magneto & Elect. Service, 103 Assembly St., Columbia, SC 29201, (803) 771-4044, SC WATS 800-922-1118 *a,c,f,g,h

TENNESSEE

American Sales & Serv., 3035 Bellbrook Dr., Memphis, TN 38116, (901) 332-2210 *a,d,f,g,h

Chilton A/C Engines, 319 4th Ave. S., Box 15806, Nashville, TN 37201, (615) 254-1634 *b,c,f,g,h

Ace Distr., Inc., 2103 E. Magnolia Ave., Box 3587, Knoxville, TN 37917, (615) 524-5359, TN WATS 800-332-9904 *a,c,f,g,h

TEXAS

Marr Bros. Inc., 423 E. Jefferson, Dallas, TX 75203, (214) 948-7387 *a,c,f,g,h

Midland Small Engine Sales, 106 Carlton, Box 4215, Midland, TX 79704, (915) 682-1409 *b,f,g,h

VIRGINIA

Norva Small Engines, 8120 E. Wellington Rd., Manassas, VA 22110, (703) 369-3387 *a,c,f,g,h

RBI Corporation, 101 Cedar Ridge Rd., Lakeridge Park, Ashland, VA 23005, (804) 798-1535 *a,c,f,g,h

WASHINGTON

Pacific A/C Engine Inc., 4030 1st Ave. S., Box 84783, Terminal Annex, Seattle, WA 98124, (206) 682-4677 *a,c,f,g,h

WEST VIRGINIA

Interstate Radiator, 1611 4th Ave., Charleston, WV 25312, (304) 345-1724 *a,d,f,g,h

WISCONSIN

Reliable Hdw., 8010 N. 76th St., Milwaukee, WI 53223, (414) 355-2900 *b,c,f,g,h

Wiggert Brothers, 3rd & Jay, Box 1267, La Crosse, WI 54601, (608) 784-4790 *a,b,c,f,g,h

CANADA

Suntester Equipment Ltd., 5466 Timberlea Blvd., Mississauga, Ontario, Canada L4W 2T7, (416) 624-6200 *g,i

Yetman's Ltd., 949 Jarvis Ave., Winnipeg, Manitoba, Canada R2X 0A1, (204) 586-8046, WATS (Manitoba & Sask.) 800-665-8623 *b,c,f,g

Revised 12/05/85

(*) General Information Codes:

- (a) Advance Payment Preferred
- (b) Accepts Credit Cards
- (c) C.O.D. okay
- (d) No. C.O.D.
- (e) C.O.D. only
- (f) Briggs & Stratton dealer or distributor
- (g) Tecumseh/Peerless dealer or distr.
- (h) Foote dealer or distributor
- (i) Dealer sales only, contact for closest dealer.