

(GB) Parts List - Riding Mower Model 42579X42

(F) Liste de pièces - Tondeuse autoportée modèle 42579X42

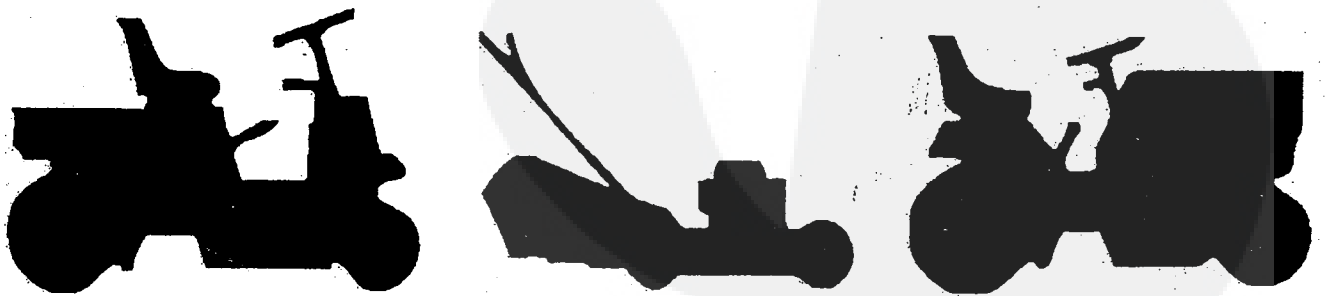

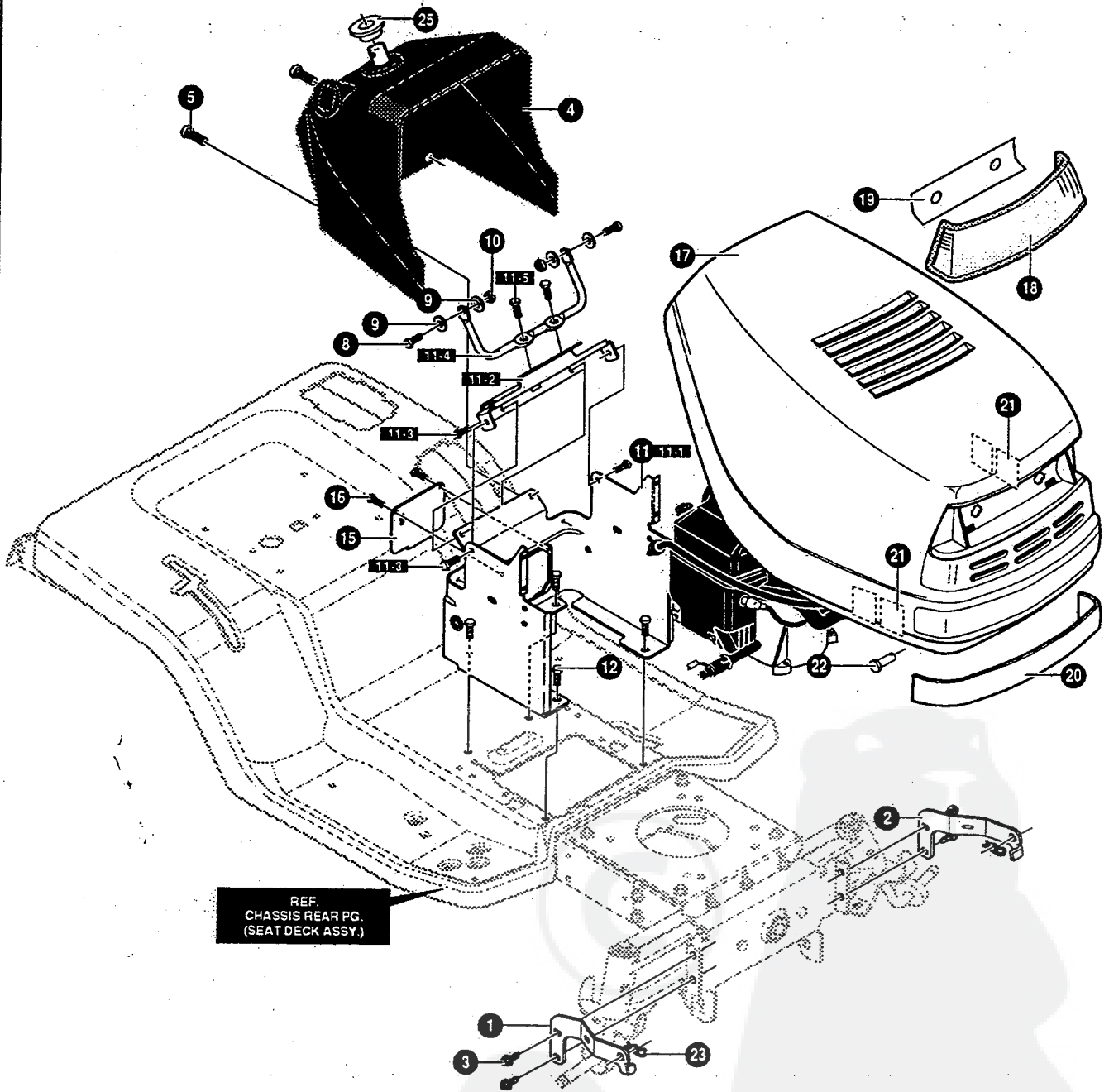

REF.
CHASSIS REAR PG.
(SEAT DECK ASSY.)

NOTE: ALWAYS USE ORIGINAL EQUIPMENT PARTS.
Use of service/replacement parts other than original
equipment parts may void your warranty.

ALL UNNUMBERED
ITEMS ARE INTERCHANGEABLE
WITH OPPOSITE SIDE

341323A

KEY NO.	PART NO.	DESCRIPTION	QTY
1	95413-853	BRACKET, HOOD RH	1
2	95414-853	BRACKET, HOOD LH	1
3	710079	SCREW, 5/16-18X.75HHWATAP	4
4	95427	DASH	1
5	710282	SCREW, 1/4-14X.75PHPANTAP	2
8	180020	SCREW, 1/4-20X.75	2
9	120392	FLATWASHER .281X.63X.065	4
10	780029	1/4-20 HEX NYLOCK NUT	2
11	341569-860	ASSY. LOWER CONSOLE	1
11-1	95425	TOWER, LOWER DASH	1
11-2	95426	SUPPORT, STEERING	1
11-3	710264	SCREW 1/4-20X.50 WAHHTAP	4
11-4	95406	ROD, DASH BRACE	1
11-5	710264	SCREW 1/4-20X.50 WAHHTAP	2
12	710079	SCREW, 5/16-18X.75HHWATAP	4
15	94638-860	ACCESS PANEL	1
16	710196	SCREW, 10-24 X.50	2
17	304188	HOOD	1
18	302670	LENS, HEADLAMP	1
19	308492	FOIL, HEAT REFLECTOR	6
22	300317	CLEVIS PIN .375DIA X.81LG	2
23	710343	HAIR PIN	2
25	95404	BUSHING, STEERING SHAFT	1
	710961	OPERATOR'S MANUAL	

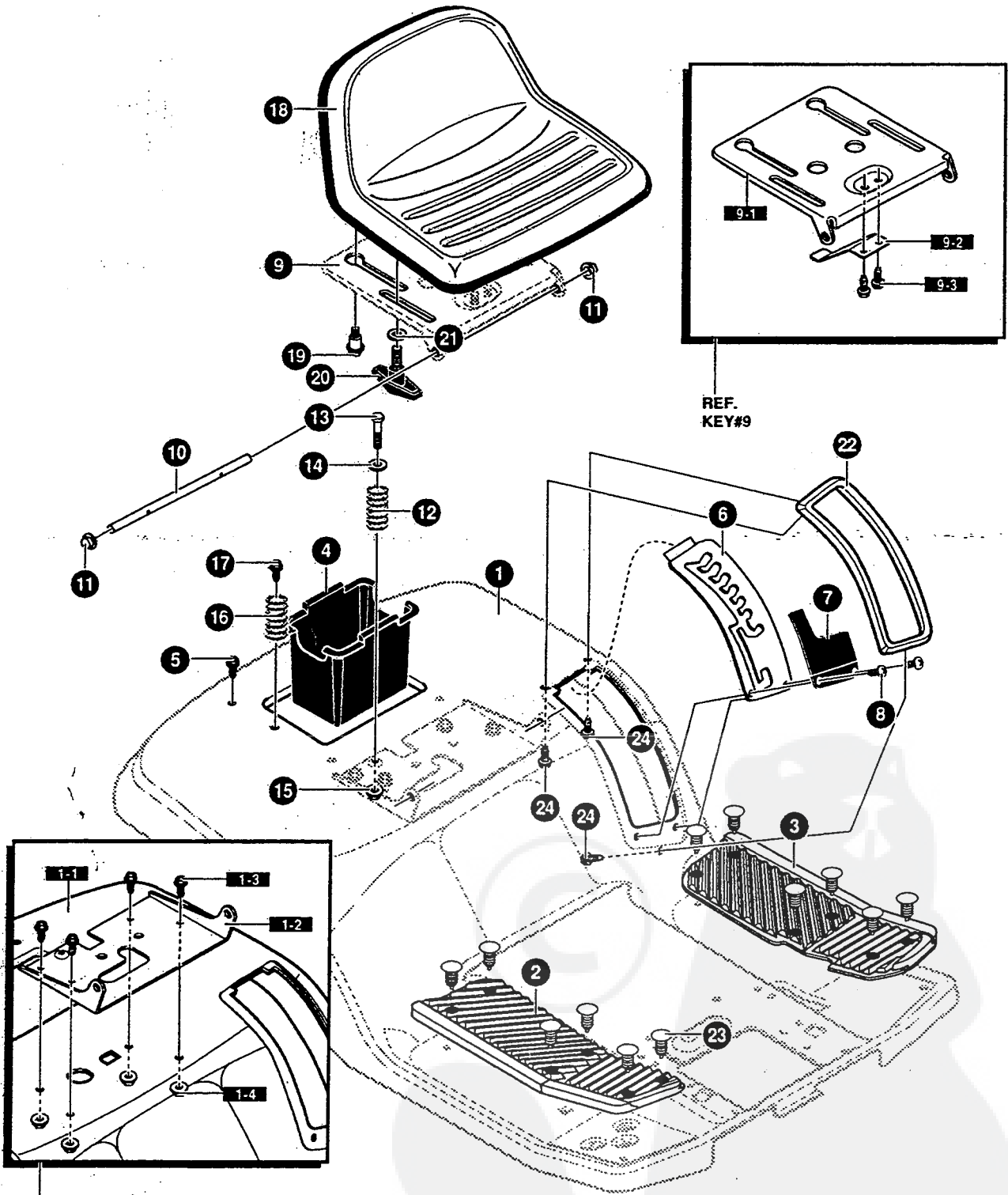

REF.
KEY#1

REF.
KEY#9

NOTE: ALWAYS USE ORIGINAL EQUIPMENT PARTS.
Use of service/replacement parts other than original
equipment parts may void your warranty.

ALL UNNUMBERED
ITEMS ARE INTERCHANGEABLE
WITH OPPOSITE SIDE

341674B

KEY NO.	PART NO.	DESCRIPTION	QTY
1	341675-860	ASM. LARGE SEAT DECK, FOOT	1
1-1	94489	SEAT DECK, LARGE FOOT HYDRO	1
1-2	94153	BRACKET, PIVOT SEAT	1
1-3	710079	SCREW, 5/16-18X.75 HHWATAP	4
1-4	710205	NUT, 5/16-18 WDFLLK (15X88)	4
2	95409	FOOTREST PAD RH	1
3	95408	FOOTREST PAD LH	1
4	94069	CONTAINER, BATTERY	1
5	710274	SCREW 1/4-20X.63 HHWATAPSER	2
6	94886-853	PLATE, LIFT DETENT LG.	1
7		NOT USED ON THIS UNIT	1
8	710196	SCREW, 10-24X.50 TRSEG	2
9	341494-860	ASM. SEAT SUPPORT	1
9-1	94154	SUPPORT, SEAT	1
9-2	94057	SPRING, LEAF	1
9-3	710264	SCREW, 1/4-20X.50 WAHHTAP	2
10	94156	ZINC HINGE SEAT PIVOT	1
11	710192	NUT, PUSH CAP .375 (28X23)	2
12	710136	SPRING, COMPRESS 4.57LGX1.17	1
13	710093	BOLT, SHOULDER 1/4-20 NC-2A (9X55)	1
14	94155	WASHER CUP ZINC	1
15	710280	NUT, 1/4-20 WDFLLK 15X89	1
16	710109	SPRING, COMPRESS 1.43LG 164X30	2
17	710079	SCREW 5/16-18X.75 HHWATAPSGIB	2
18	95436	SEAT MICHIGAN V540	1
19	710101	BOLT, SHOULDER 5/16-18 NC 9X56	2
20	94160	BOLT, WING 5/16-18X.50 LG THRD	2
21	710281	WASHER, FLAT .344X.62X.06	2
22	94490	COVER, LIFT DETENT	1
23	309235	FASTENER, RATCHET	12
24	311331	SCREW, 1/4-15X.44/.53 HILOHHWA	3

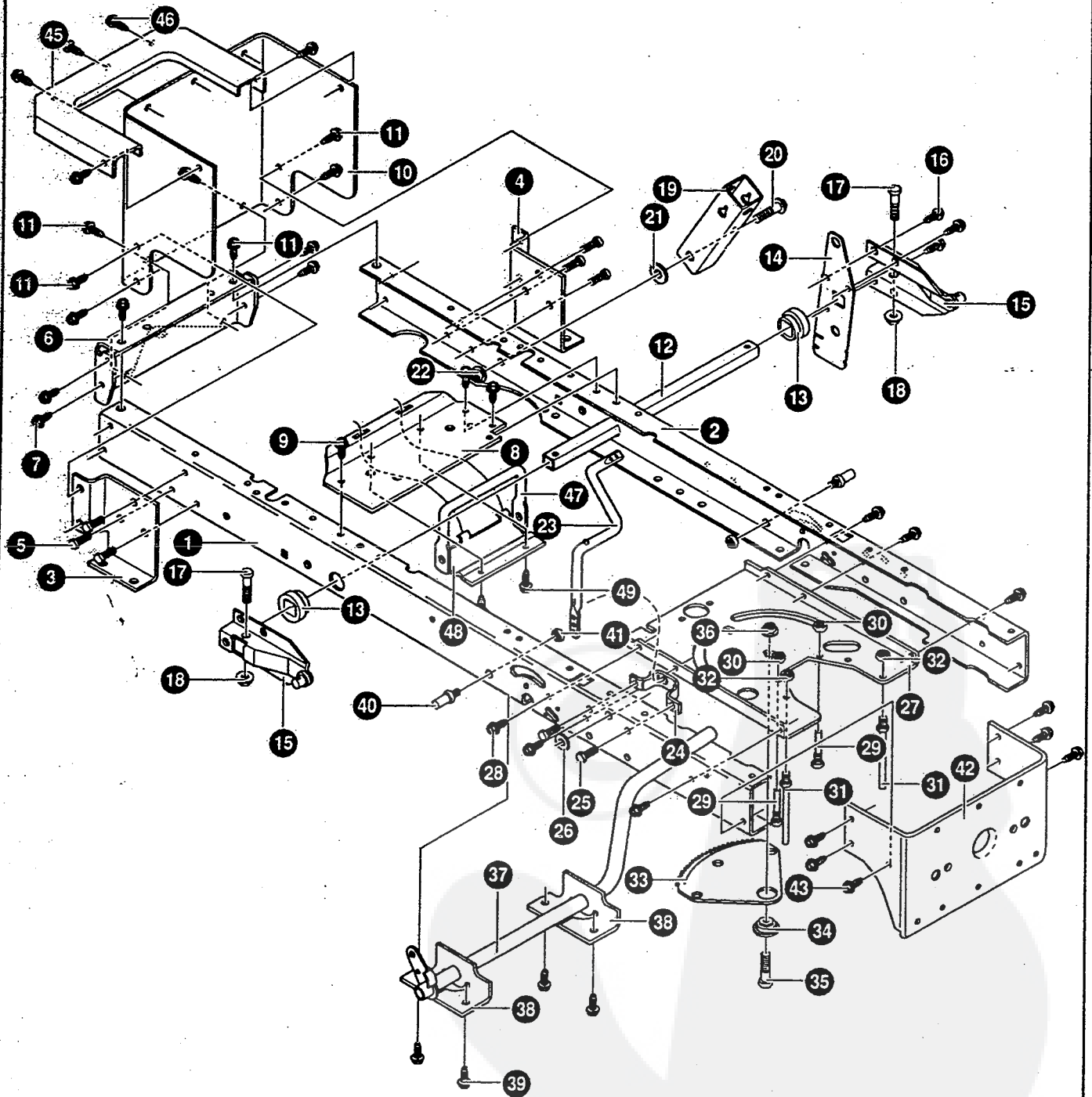

NOTE: ALWAYS USE ORIGINAL EQUIPMENT PARTS.
Use of service/replacement parts other than original equipment parts may void your warranty.

ALL UNNUMBERED
ITEMS ARE INTERCHANGEABLE
WITH OPPOSITE SIDE

341410A

KEY PART NO. NO.	DESCRIPTION	QTY
1 94000	FRAME, RAIL RH	1
2 94001	FRAME, RAIL LH	1
3 94184	BRACKET, TRANSAXLE RH	1
4 94185	BRACKET, TRANSAXLE LH	1
5 710079	SCREW, 5/16-18X.75HHWATAP	6
6 94002	HITCH PLATE	1
7 710079	SCREW, 5/16-18X.75HHWATAP	4
8 94431	BRACKET, IDLER/TRUNNION SUPP	1
9 710079	SCREW 5/16-18X.75HHWATAP	3
10 94187	PLATE, REAR LARGE SEAT DECK	1
11 710079	SCREW 5/16-18X.75 HHWATAP	6
12 94063	TUBE, LIFTER	1
13 94065	BUSHING, LIFT TUBE	2
14 94030	PLATE-LIFT ARM	1
15 94180	ASSY, LIFT ARM LEVER	2
16 710106	SCREW, 5/16-18X.50WHHTAP (26X49)	3
17 710310	SCREW, 5/16-24X1.25	2
18 710080	NUT, 5/16-24 NF-2 HEXFLLK	2
19 94015	BRACKET, PIVOT	1
20 710000	BOLT, .562X1.563 HSSH 3/8-16	1
21 710730	FLATWASHER .406ID (17X191)	1
22 710140	NUT, 3/8-16 HWDFLK MACK 15X84	1
23 94019	CRANK, PTO (DRILLED)	1
24 94005	BRACKET, BELL CRANK	1
25 710079	SCREW, 5/16-18X.75HHWATAP	2
26 120395	FLATWASHER .469X.92X.065	1
27 94003	PLATE, STEERING MOUNTING	1
28 710079	SCREW, 5/16-18X.75HHWATAP	6
29 93349	SCREW GUIDE 5/16-18	2
30 710204	NUT, 5/16-18 HEXWEFLLK WHIZ	2
31 94066	SCREW-GUIDE	2
32 710204	NUT, 5/16-18 HEXWDFLLK WHIZ	2
33 94121	SECTOR GEAR	1
34 94123	BEARING, SECTOR GEAR	1
35 710312	SCREW, 5/16-18X1.00 HHC	1
36 710105	NUT, 5/16-8 HKEPS 15X113	1
37 94038	ASSEMBLY, BRAKE LEVER	1
38 94035	BRACKET, PEDAL PIVOT	2
39 710079	SCREW, 5/16-18X.75 HHWATAP	4
40 94067	PIN, THREADED SHOULDER	2
41 45171	NUT, 3/8-16HWDFLWHIZ-LOCK	2
42 94013	BRACKET, HANGER REAR	1
43 710079	SCREW, 5/16-18X.75 HHWATAP	6
45 94186	TOP, REAR PLATE LARGE SEAT DECK	1
46 710196	SCREW 10-24X.500TRSEGI	5
47 94425	ROD, TRUNNION YOKE (PEERLESS)	1
48 94434	CLAMP, TRUNNION PIVOT PEERLESS	2
49 710079	SCREW 5/16-18X.75HHWATAP	2

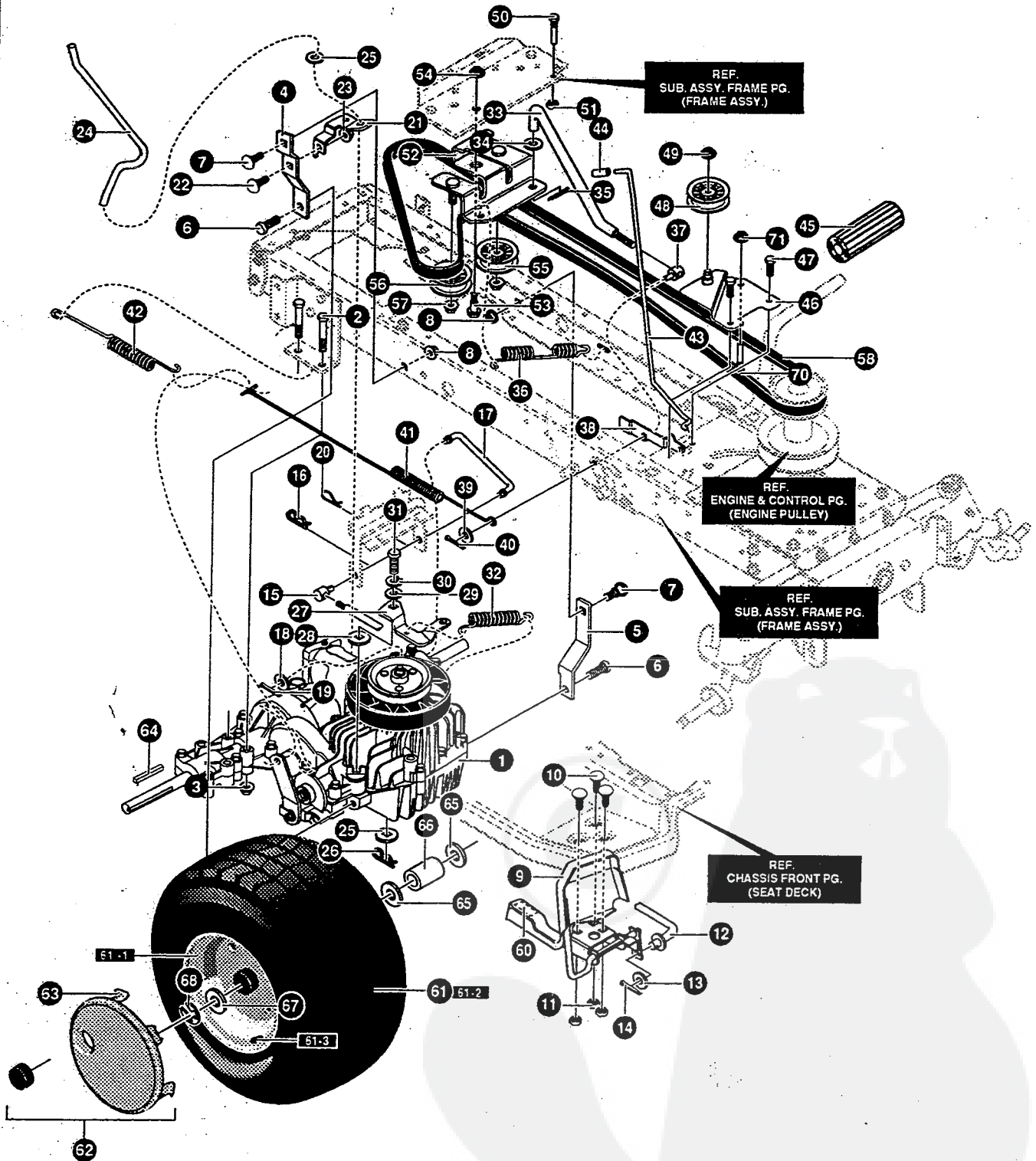

NOTE: ALWAYS USE ORIGINAL EQUIPMENT PARTS.
Use of service/replacement parts other than original equipment parts may void your warranty.

ALL UNNUMBERED
ITEMS ARE INTERCHANGEABLE
WITH OPPOSITE SIDE

KEY NO.	PART NO.	DESCRIPTION	QTY
1		HYDRO PEERLESS 205-024	1
2	180091	SCREW, 5/16-18X2.50 HHC	4
3	710205	NUT, 5/16-18 WDFLLK (15X88)	4
4	94432-853	TORQUE STRAP	1
5	94433-853	TORQUE STRAP-LEFT	1
6	710268	SCREW, 5/16-18X .75 WAHHTAP	2
7	57072	BOLT, CARR. 5/16-18X.63	2
8	710205	NUT, 5/16-18 WDFLLK (15X88)	2
9	94422-853	PEDAL ASSEMBLY	1
10	57101	BOLT, 5/16-18X.75 CARR.	3
11	710205	NUT, 5/16-18 WDFLLK (15X88)	3
12	694424	ROD, PEDAL LINK (PEERLESS)	1
13	710238	WASHER, .469X.72 (17X57)	1
14	710107	COTTER PIN 30X20	1
15	92132	ADJUSTING NUT 1/2-13	1
16	710343	PIN, HAIR .38DIAX1.64LLG	1
17	94426	ROD, HYDRO LINK	1
18	710119	WASHER FLAT	1
19	710107	PIN, COTTER .094DIAX.75 30X20	1
20	710108	HAIR PIN (31X4)	1
21	94429-853	BRACKET, DISCONNECT	1
22	57072	BOLT, 5/16-18X.63 CARR.	1
23	710204	NUT, 5/16-18 HEXWDFLLK WHIZ	1
24	94428	ZINC ROD, DISCONNECT	1
25	710281	FLATWASHER .344X.62X.06	1
26	710107	PIN, COTTER .094DIAX.75 30X20	1
27	94430-853	ARM, DISCONNECT	1
28	710346	WASHER .388X.393	1
29	710657	FLATWASHER .256X.75X.130	1
30	710249	WASHER (18X32)	1
31	710345	SCREW, 1/4-28X.75	1
32	710330	SPRING, EXTENSION	1
33	94417	CLUTCH ROD	1
34	710281	WASHER, FLAT .344X.62X.06	1
35	710107	PIN, COTTER .094DIAX.75 30X20	1
36	710707	SPRING, CLUTCH	1
37	94815	NUT, ADJUSTING	1
38	94045	LATCH, PARK BRAKE	1
39	710142	WASHER, FLAT .406X.81	1
40	710107	COTTER PIN .094DIAX.75 30X20	1
41	710333	SPRING, EXTENSION	1
42	710353	SPRING, TENSION	1
43	94568	PARK BRAKE CONTROL ROD	1
44	335980	CAP, DUMP VALVE ROD	1
45	21544	PEDAL, BRAKE/CLUTCH	1
46	94409-853	ASSY, IDLER INTERMEDIATE	1
47	710708	BOLT, 5/16-18 X.50	2
48	91179	PULLEY, IDLER	1
49	710140	NUT, 3/8-16 HWDFLLK MACK 15X84	1
50	93349	SCREW GUIDE 5/16-18	2
51	710204	NUT, 5/16-18 HEXWDFLLK WHIZ	2
52	694411	ASSY, BRACKET IDLER	1
53	710098	BOLT, .50X.75 HSH 3/8-16 9X39	1
54	710140	NUT, 3/8-16 HWDFLLK MACK 15X84	1
55	91179	PULLEY, IDLER	1
56	91178	PULLEY, V-IDLER 3"	1
57	710140	NUT, 3/8-16 HWDFLLK MACK 15X84	1
58	710531	BELT, MOTION HYDRO 37X61	1
59	93248	PEDAL, PAD SANDPAPER	1
60	93249	PAD, TOE SANDPAPER	1
61	692290	TIRE & RIM 20X8.00-8	2
61-1	338512	VALVE STEM	2
61-2	338524	RIM, CARL	2
61-3	338526	TIRE 20X8-8	2
64	52928	KEY, SQUARE .187SQX2.25LG	2
65	710351	WASHER, FLAT .760X1.25X.065	4
66	95421	SPACER, .87x1.78 MURRAY #87x105	2
67	710088	FLATWASHER .765X1.81X.059	2
68	36625	RING, RETEX .57X.05TRU5133-75	2
70	93349	SCREW GUIDE 5/16-18	1
71	710204	NUT, 5/16-18 HEXWDFLLK WHIZ	1

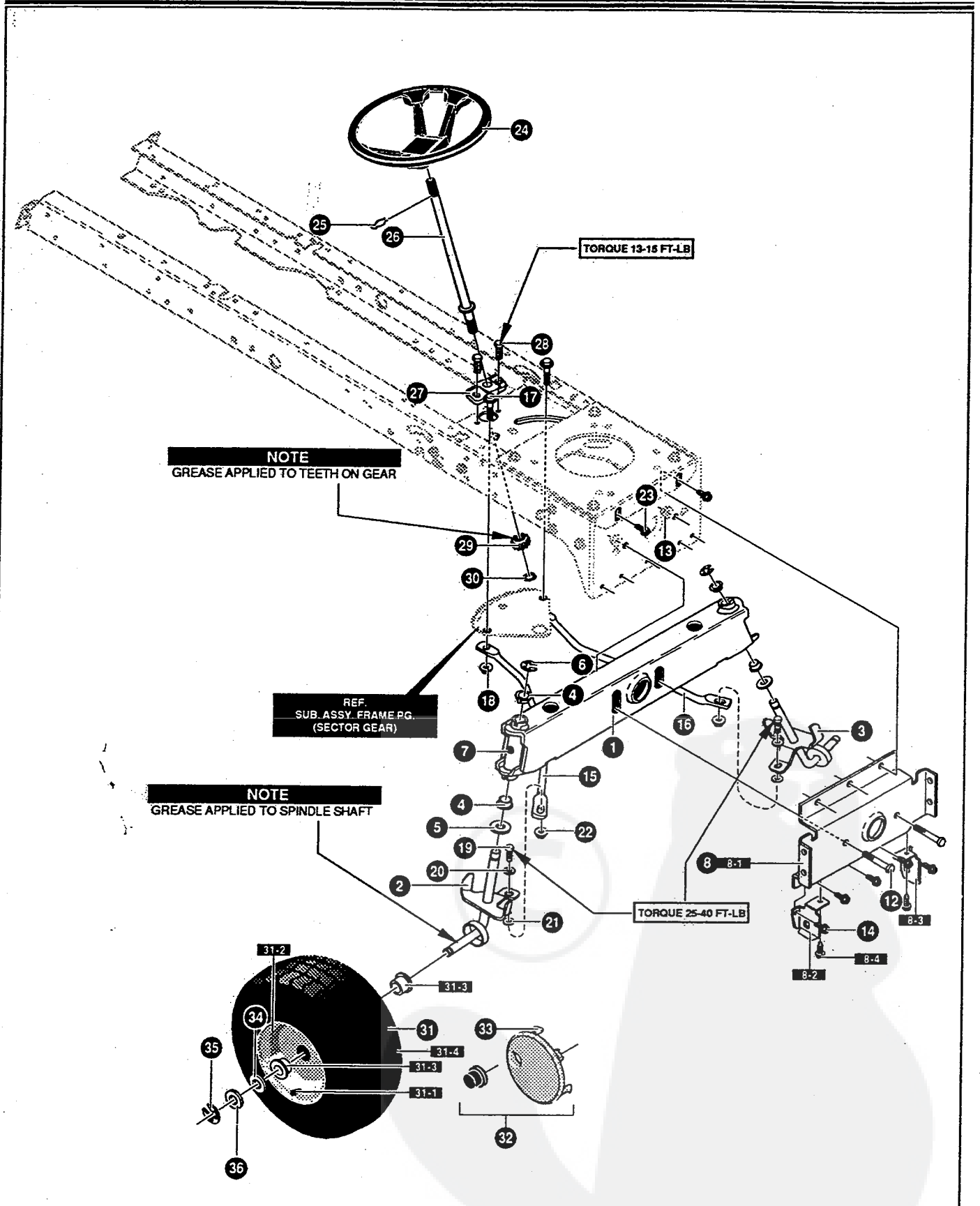

NOTE: ALWAYS USE ORIGINAL EQUIPMENT PARTS. Use of service/replacement parts other than original equipment parts may void your warranty.

ALL UNNUMBERED ITEMS ARE INTERCHANGEABLE WITH OPPOSITE SIDE

341359A

KEY #	PART #	DESCRIPTION	QTY
1	94012-853	AXLE ASSEMBLY	1
2	94178-853	SPINDLE,RH (94178)	1
3	94179-853	SPINDLE LH	1
4	92527	BEARING, SPINDLE	4
5	710129	WASHER,.766 ID X 1.62ID 16GA	2
6	710103	E-RING .574IDX.050/.750SH (11X3)	2
7	706	ZERK, GREASE FITTING	2
8	341490-853	ASM.FRONT AXLE/DECK HANGER	1
8-1	94007	HANGER, AXLE	1
8-2	94026	HANGER DECK RH	1
8-3	94027	HANGER DECK LH	1
8-4	710079	SCREW, 5/16-18X.75HHWATAPSGIBP	2
12	710081	SCREW, 5/16-24X2.75	2
13	710080	NUT, 5/16-24 NF-2 HEXFLK	2
14	710079	SCREW, 5/16-18X.75HHWATAPSGIBP	2
15	94020-853	DRAG LINK, RH	1
16	94021-853	DRAG LINK, LH	1
17	710440	BOLT,HSSH (9X57)	2
18	710140	NUT,3/8-16HWDFLK MACK (15X84)	2
19	710082	SCREW, 3/8-16X1.5 HHCFLTHR	2
20	710083	WASHER, FLAT .391X1.00X.083	2
21	710142	WASHER, FLAT.406X .81X16GA	2
22	710140	NUT,3/8-16HWDFLK MACK (15X84)	2
23	710079	SCREW, 5/16-18X.75HHWATAPSGIBP	3
24	95441	STEERING WHEEL	1
26	94127	SHAFT, STEERING	1
27	94124	BEARING-LOWER	1
28	710079	SCREW, 5/16-18X.75HHWATAPSGIBP	2
29	94122	GEAR PINION	1
30	710102	RING, RET E.54ID .59SH (11X25)	1
31	692287	TIRE&RIM, PU 15X6.0-6	2
31-1	338512	VALVE STEM	2
31-2	338517	RIM	2
31-3	338513	BEARING	2
31-4	338516	TIRE 15X6-6	2
32		NOT USED ON THIS UNIT	
33		NOTUSED ON THIS UNIT	
34	710131	WASHER, FLAT .759ID (340435)	2
35	36625	RING, RETEX .57X.05TRU5133-75	2
36	710350	WASHER, FLAT .765X1.62X.065	2

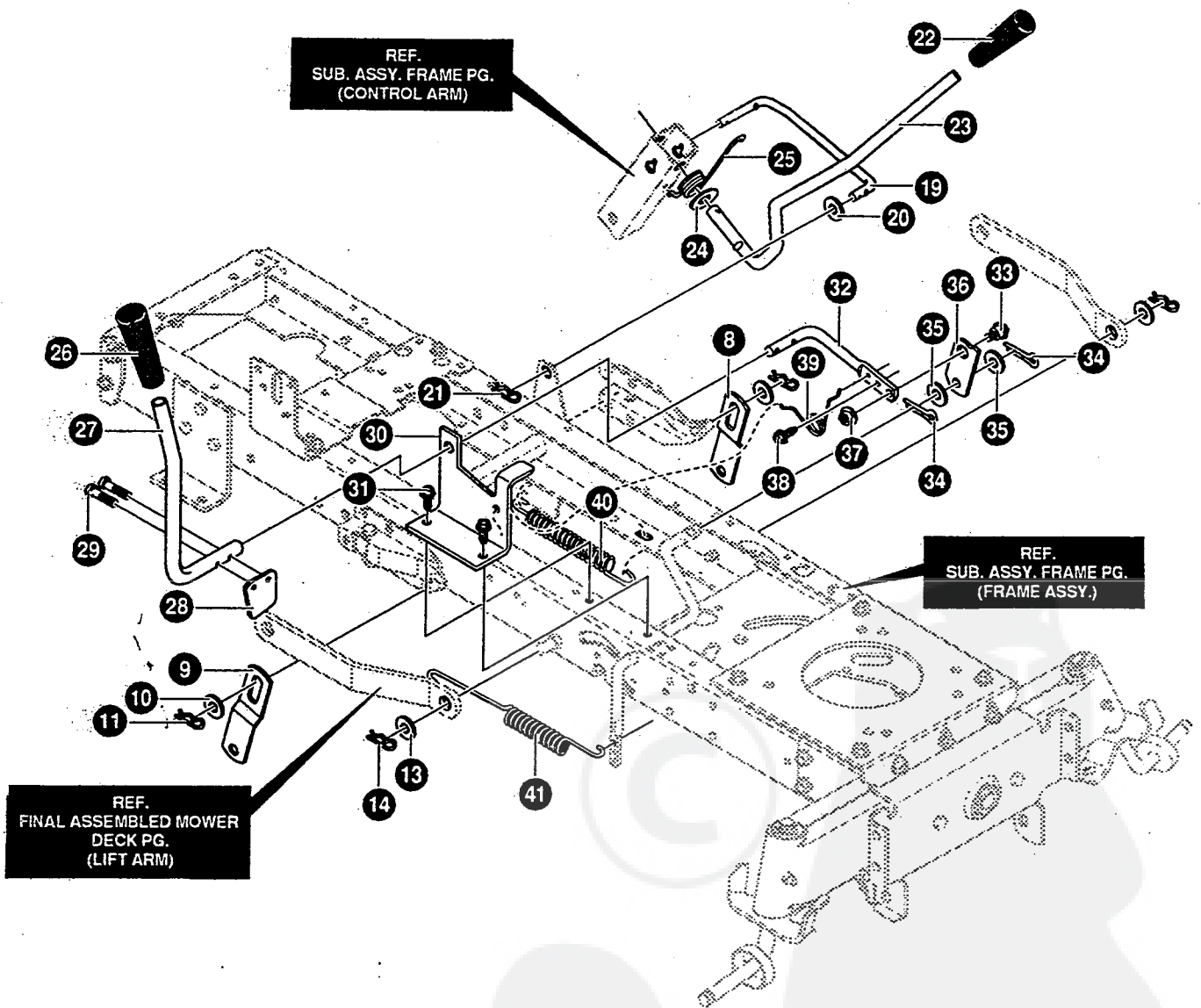

NOTE: ALWAYS USE ORIGINAL EQUIPMENT PARTS.
Use of service/replacement parts other than original equipment parts may void your warranty.

ALL UNNUMBERED
ITEMS ARE INTERCHANGEABLE
WITH OPPOSITE SIDE

341739A

KEY NO.	PART NO.	DESCRIPTION	QTY
8	94611-853	LINK, LIFT RH	1
9	94053-853	LINK-LIFT	1
10	710119	FLATWASHER (17X91)	2
11	710108	PIN, HAIR (31X4)	2
13	710119	WASHER, FLAT (17X91)	2
14	710108	PIN, HAIR (31X4)	2
19	94028	ZINC LINK LIFT HANDLE	1
20	710119	WASHER, FLAT (17X91)	1
21	710108	PIN, HAIR (31X4)	1
22	92697	GRIP, BLACK	1
23	94195	HANDLE, LIFT	1
24	710116	WASHER, FLAT .550X1.00X11 (17X103)	1
25	710111	TORSION SPRING, .657LG (166X40)	1
26	92698	GRIP, BLACK	1
27	94826	PTO LEVER	1
28	94022	PADDLE, SWITCH	1
29	710137	SCREW, THD FORMING .246X1.050LG	2
30	94018-853	BRACKET, PTO	1
31	710079	SCREW, 5/16-18X.75 HHWATAP	2
32	94017	LEVER, PTO	1
33	710098	BOLT, .50X.75 HSH 3/8-16 9X39	1
34	36368	PIN, HAIR .072 DIA X 1.13LG	2
35	710115	WASHER, FLAT .518X.87X16 17X102	2
36	94004	LINK PTO	1
37	710140	NUT, 3/8-16 HWD FLLK MACK 15X84	1
38	710079	SCREW, 5/16-18X.75 HHWATAP	1
39	710141	TORSION SPRING .33LG (166X39)	1
40	710311	SPRING, TENSION 1.01OD 8.18LG	1
41	710208	EXTENSION SPRING (165X119)	1

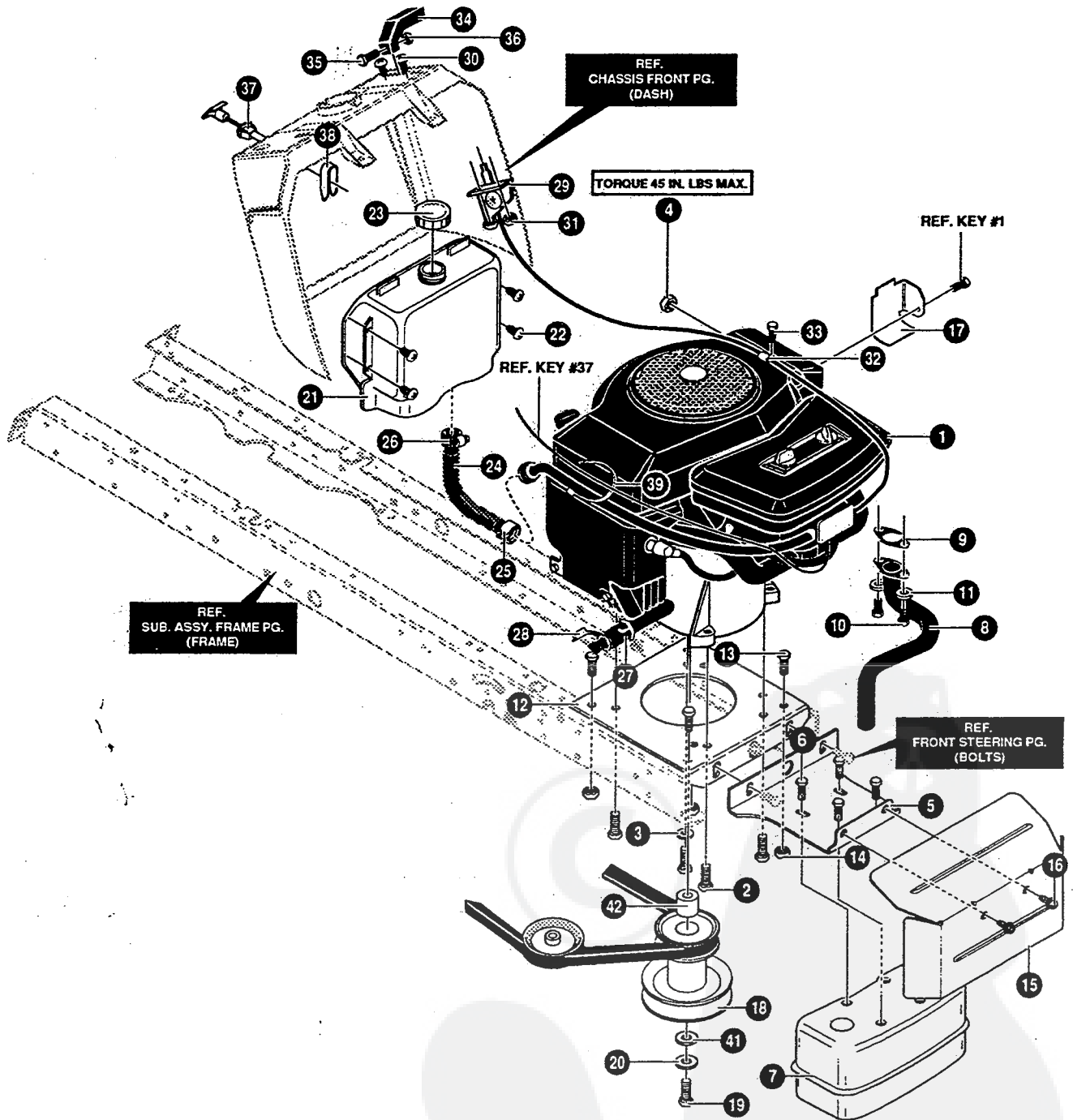

NOTE: ALWAYS USE ORIGINAL EQUIPMENT PARTS.
 Use of service/replacement parts other than original
 equipment parts may void your warranty.

ALL UNNUMBERED
 ITEMS ARE INTERCHANGEABLE
 WITH OPPOSITE SIDE

341799A

KEY PART NO. NO.	DESCRIPTION	QTY
1	ENGINE 14-18HP STD/IC (SEE ENGINE MANUAL)	1
2	50947 SCREW, 3/8-16X1.25WAHHTAP	4
3	138489 WASHER, EXLK .384X.69X.04	1
4	124818 NUT, 1/4-20 REGHXJAM	1
5	94306-853 BAFFLE, REAR ENGINE	1
6	44811 SCREW, 1/4-20X.75 WAHHTAP	4
7	94655 MUFFLER TWIN-CYCLINDER	1
8	94660 EXHAUST MANIFOLD	1
9	56640 GASKET, MUFFLER	1
10	180020 SCREW, 1/4-20X.75	2
11	120380 WASHER, RESPTLK	2
12	94006-853 ENGINE PLATE	1
13	710079 SCREW, 5/16-18 X.75HHWATAP	4
14	710205 NUT, 5/16-18 WDFLLK (15X88)	4
15	94981-853 HEAT SHIELD	1
16	710079 SCREW, 1/4-20X.75 WAHHTAP	2
17	56470-853 DEFLECTOR, COOL AIR	1
18	94407 PULLEY, STACK ASSY	1
19	120383 WASHER, REGS[T;L /459X.78X.12	1
20	710248 SCREW 7/16-20	1
21	314991 TANK FUEL 2-GAL	1
22	57220 SCREW #12X.50 PHPNHTAP	4
23	300304 CAP, GAS	1
24	57876 TUBING, .25X.50	13 IN.
25	47345 CLAMP, HOSE SCREW TYPE	1
26	47345 CLAMP, HOSE SCREW TYPE	1
27	325547 OIL DRAIN VALVE ASSEMBLY	1
28	327422 CAP, OIL DRAIN VALVE ASSY	1
29	309092 THROTTLE CONTROL	1
30	320553 SCREW, 10-24X.63 PHPNMA	2
31	308459 NUT, #10-24 HXHDNYLK	2
32	57569 RETAINER .31IDX.62X.03 WIRE	1
33	35258 SCREW, 10-24X.38 SLHWATAP	1
34	300508 KNOB, THROTTLE CONTROL	1
35	159585 SCREW, #8-32X.38 PHPNMA	1
36	120622 NUT, #8-32 REGHX	1
37	94891 CHOKE	1
38	314522 CLIP, CHOKE CONTROL	1
39	57444 TIE, CABLE	1
40	94894 CLIP, SPEED	1
41	710247 FLATWASHER .480X1.00X.25	1
42	93077 SPACER, SLEV	1

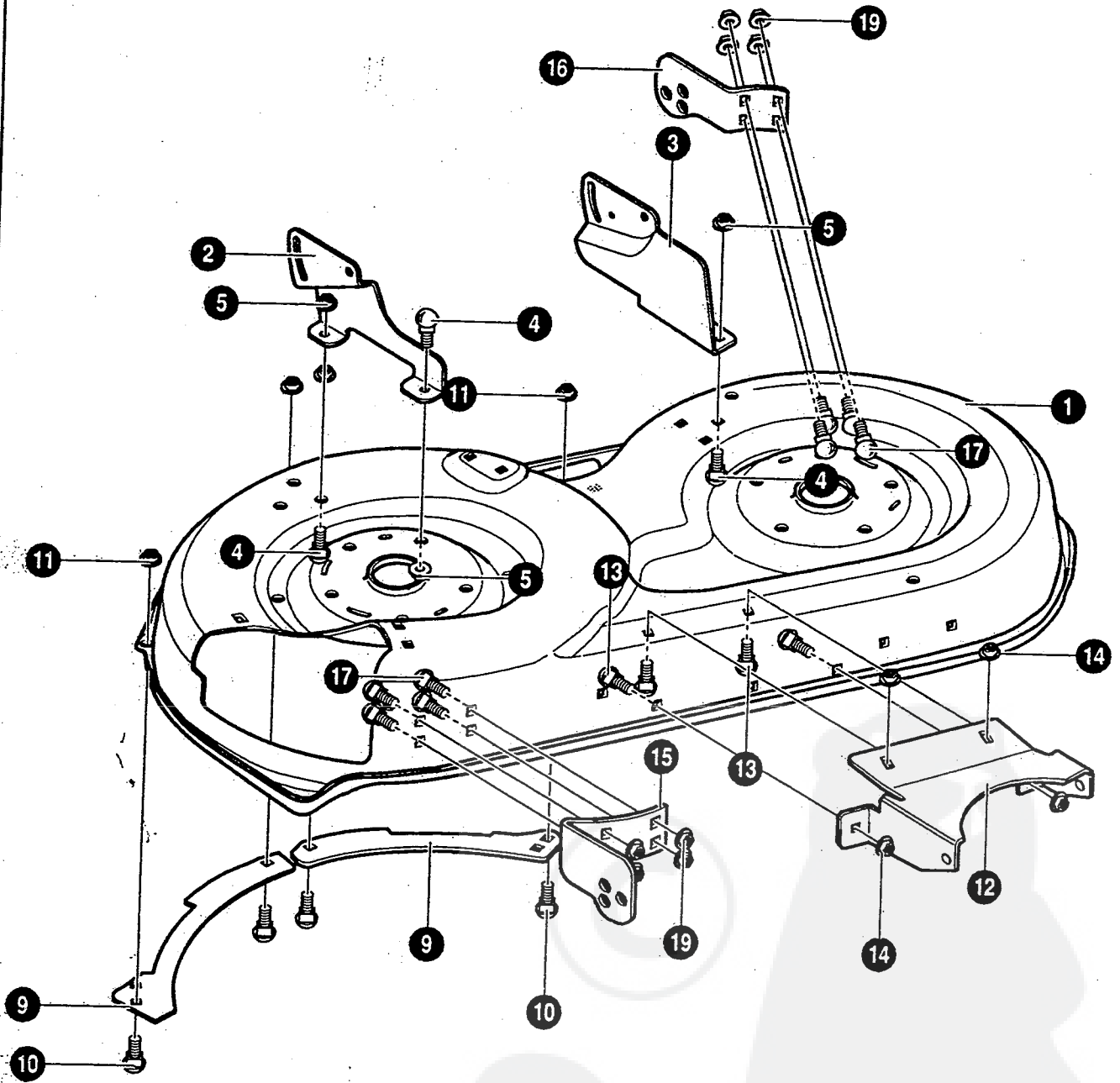

NOTE: ALWAYS USE ORIGINAL EQUIPMENT PARTS.
Use of service/replacement parts other than original
equipment parts may void your warranty.

ALL UNNUMBERED
ITEMS ARE INTERCHANGEABLE
WITH OPPOSITE SIDE

94189A

KEY NO.	PART NO.	DESCRIPTION	QTY
1	94188	HOUSING, BLADE 42"	1
2	94191	BRACKET, DECK RH	1
3	94192	BRACKET, DECK LH	1
4	57072	BOLT, 5/16-18X.63 CARR.	5
5	710204	NUT, 5/16-18 HEXWDFLLK WHIZ	5
9	92426	TOEGUARD, FLANGE	2
10	57072	BOLT, 5/16-18X.63 CARR.	2
11	710205	NUT, 5/16-18 WDFLLK (15X88)	2
12	94190	ASSY, FRONT DECK	1
13	57072	BOLT, 5/16-18X.63 CARR.	4
14	710204	NUT, 5/16-18 HEXWDFLLK	4
15	92422	BRACKET, 42" DECK RH WHEEL	1
16	92423	BRACKET, 42" DECK LH WHEEL	1
17	57072	BOLT, 5/16-18X.63 CARR.	7
19	710205	NUT, 5/16-18 WDFLLK (15X88)	7

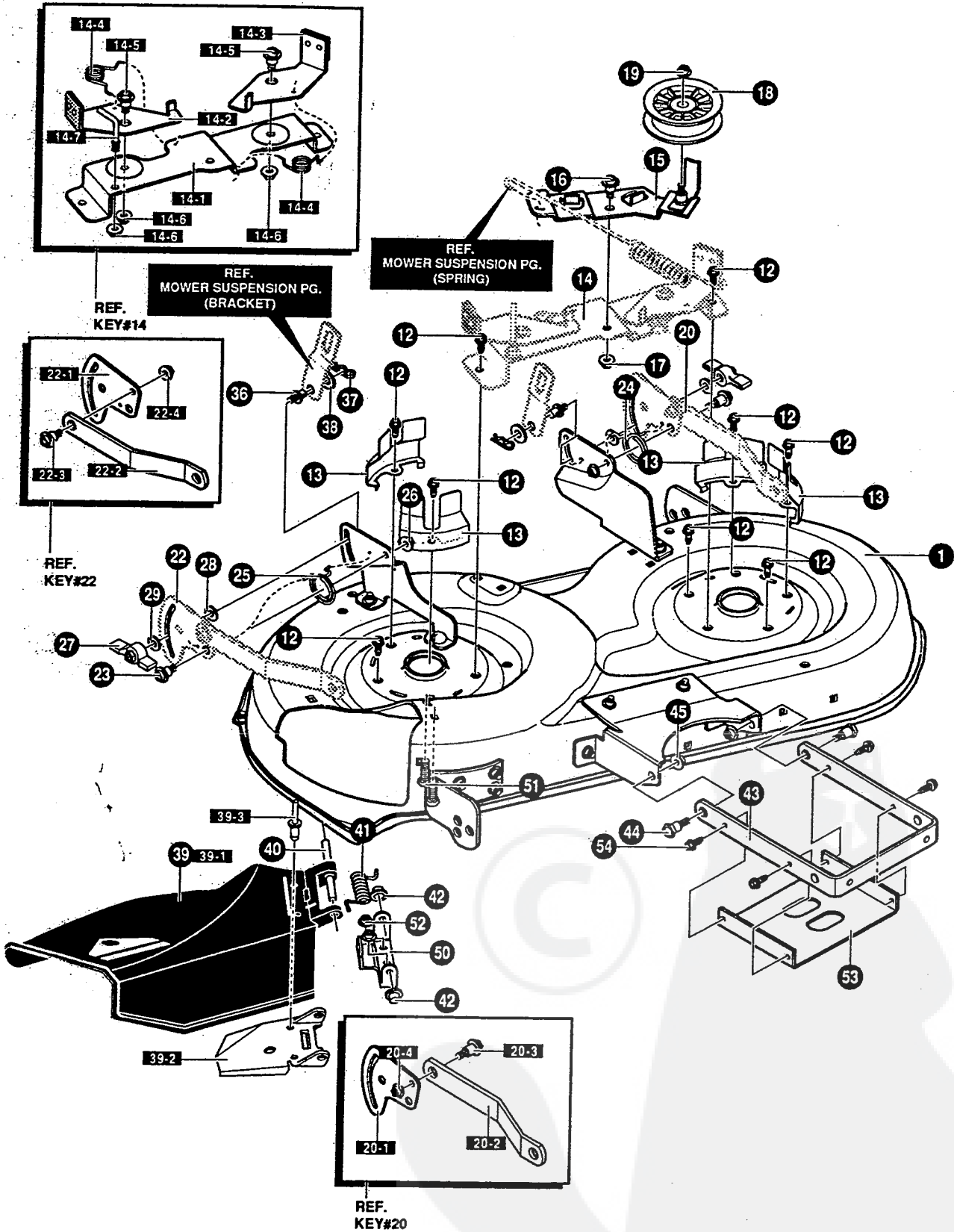

NOTE: ALWAYS USE ORIGINAL EQUIPMENT PARTS. Use of service/replacement parts other than original equipment parts may void your warranty.

ALL UNNUMBERED ITEMS ARE INTERCHANGEABLE WITH OPPOSITE SIDE

341275A

KEY NO.	PART NO.	DESCRIPTION	QTY
1	94189-853	ASM, BLADE HOUSING 42" MIDLINE	1
12	710199	SCREW, 3/8-16X1.25 WAHHSPTAPP	10
13	94051-853	COVER, SEGMENT BELT GUIDE	4
14	94714-853	ASM., BRACKET SUP W/BRAKES 42"	1
14-1	94193	BRACKET, BRAKE MT	1
14-2	94047	ASSY, BRAKE RH	1
14-3	94049	ASSY, BRAKE RH MO#94049	1
14-4	710227	TORSION SPRING (166X41)	2
14-5	710098	BOLT .50X.75 HSH 3/8-16 (9X39)	2
14-6	710140	NUT, 3/8-16 HWDFLLK MACK (15X84)	3
14-7	94781	SCREW GUIDE	1
15	94177-853	ASSY, IDLER ARM	1
16	710098	BOLT .50X.75 HSH 3/8-16Z 9X39	1
17	710140	NUT, 3/8-16 HWDFLLK MACK 15X84 Z	1
18	91801	PULLEY, IDLER BFF 4.75 DIA.	1
19	710140	NUT, 3/8-16 HWDFLLK MACK 15X84 Z	1
20	341594-853	ASM. PLATE, REAR SUS. BRKT. LH	1
20-1	94128	PLATE - SUSPENSION	1
20-2	94055	SUSPENSION BRKT REAR	1
20-3	710095	BOLT, SHOULDER 3/8-16 (9X52)	1
20-4	710140	NUT, 3/8-16 HWDFLLK MACK 15X84 Z	1
22	341593-853	ASM. PLATE, REAR SUS. BRKT. RH	2
22-1	94128	PLATE - SUSPENSION	1
22-2	94055	SUSPENSION BRKT REAR	1
22-3	710095	BOLT, SHOULDER 3/8-16 (9X52)	1
22-4	710140	NUT, 3/8-16 HWDFLLK MACK 15X84 Z	1
23	710094	BOLT, SHOULDER .375 (9X51)	2
24	710113	SPRING, TORSION .68LG LH 166X43	1
25	710112	SPRING, TORSION .68LG RH 166X42	1
26	710140	NUT, 3/8-16 HWDFLLK MACK 15X84 Z	2
27	94068	KNOB	2
28	94137	PAD, FRICTION	2
29	710195	WASHER, (17X45)	2
36	94064	PIN, HANGER	2
37	710108	PIN, HAIR (31X4)	2
38	710116	WASHER, FLAT .550X1.00X11 17X103 Z	2
39	94452	ASSEMBLY, CHUTE DEFLECTOR	1
39-1	94133	CHUTE DEFLECTOR	1
39-2	94686	DEFLECTOR SUPPORT	1
39-3	710181	RIVET, SEMI (7X125)	2
40	91767	ROD, CHUTE DEFLECTOR	1
41	710194	SPRING, TORSION .44X2.06X	1
42	710192	NUT, PUSH CAP .375 (28X23) Z	2
43	94058	BRACKET, FRT SUSPENSION	1
44	710094	BOLT, SHOULDER .375 (9X51)	2
45	710140	NUT, 3/8-16 HWDFLLK MACK 15X84 Z	2
50	91765-853	BRACKET, CHUTE ATTACH	1
51	57072	BOLT, 5/16-18X .63 CARRLN	2
52	710205	NUT, 5/16-18 WDFLLK (15X88) Z	2
53	94604-853	STIFFENER NLT	1
54	710079	SCREW, 5/16-18X.75HHWATAPSGIBP	4

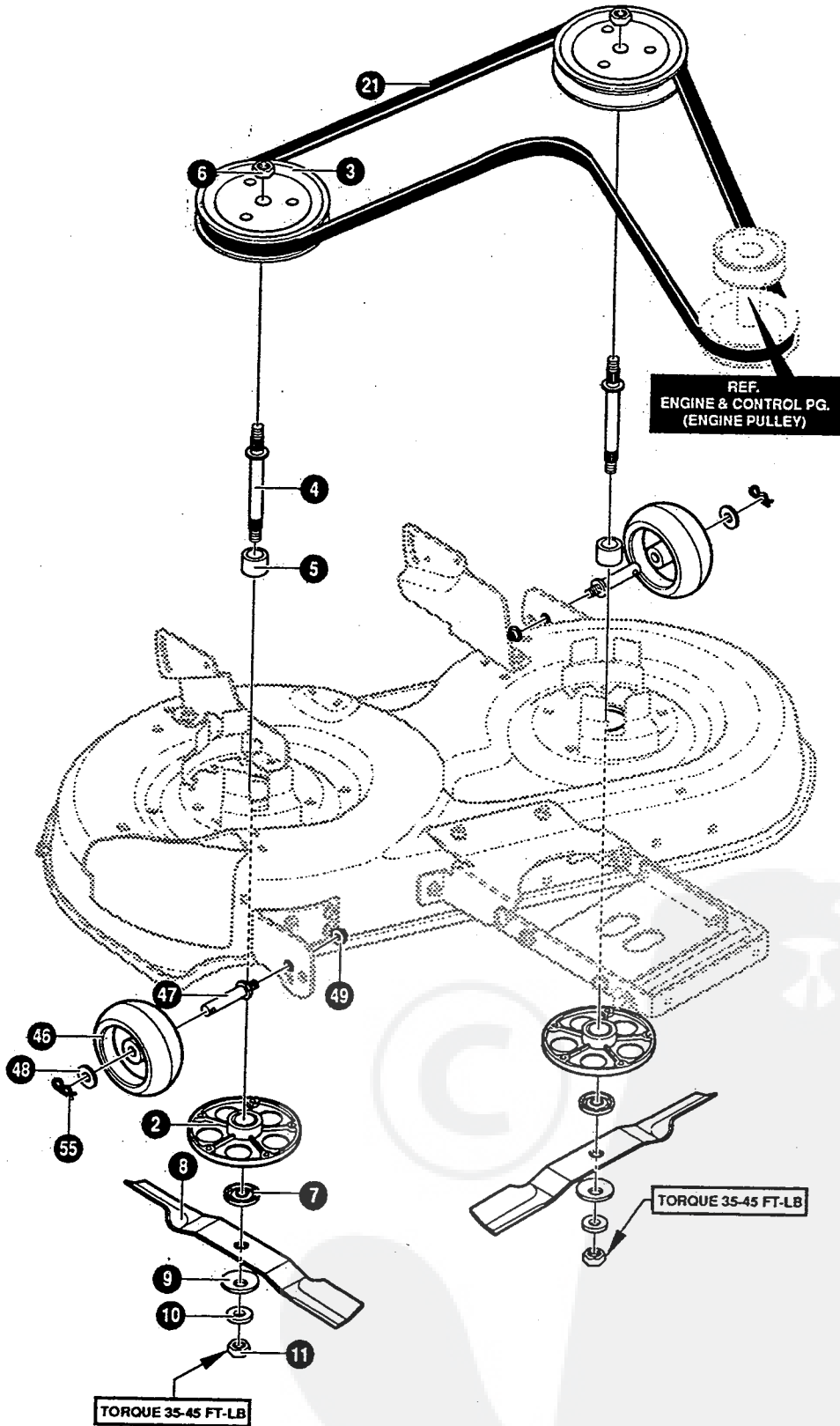

NOTE: ALWAYS USE ORIGINAL EQUIPMENT PARTS. Use of service/replacement parts other than original equipment parts may void your warranty.

ALL UNNUMBERED ITEMS ARE INTERCHANGEABLE WITH OPPOSITE SIDE

341275A

KEY NO.	PART NO.	DESCRIPTION	QTY
2	92574	JACKSHAFT ASSEMBLY HOUSING 42"	1
3	94199	PULLEY, INPUT 42"	2
4	94129	JACKSHAFTR 7.12LG	2
5	94130	SPACER .625X.875X1.858	2
6	710191	NUT, 9/16-18 UNF-2B (15X121)	2
7	92466	ADAPTER, DECK/BLADE	2
8	92418	BLADE, 42"	2
9	710118	WASHER, BELLVILLE .625X1.75 (17X166)	2
10	710117	WASHER, FLAT .625X1.00X.188	2
11	710104	NUT, 9/16 REGHEX (15X100)	2
21	710213	BELT, 42" DECK (37X88)	1
46	92683	GAUGE, WHEEL 4.494 DIA.	2
47	94025	BOLT, SPSH 3/8-16X.63 3.00LG	2
48	710115	WASHER, FLAT .518X.87X16 17X102	2
49	710140	NUT 3/8-16 HWDFLK MACK 15X84	2
55	710708	PIN, HAIR (31X4)	2

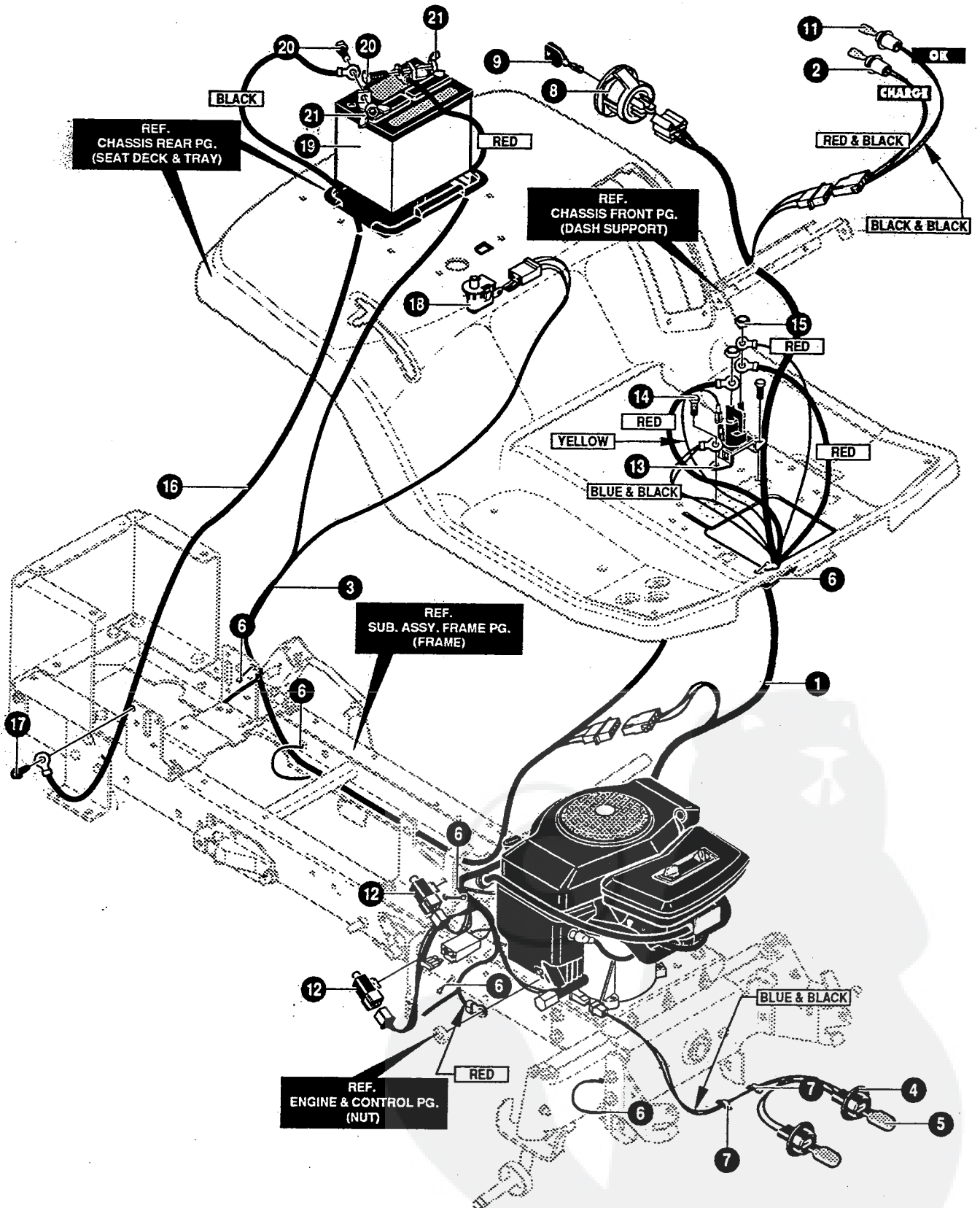

KEY NO.	PART NO.	DESCRIPTION	QTY
1	94743	HARNES 14-20 OPP. TWIN	1
2	94740	HARNES ADAPTER,OK/CHARGE IL	1
3	94741	WIRE HARNES, REAR	1
4	303064	ASSY,LIGHT WIRE-1/4 TURN	1
5	52572	BULB, HEADLAMP	2
6	57444	TIE, CABLE BLACK NYLON 5.62L	2
7	41482	PRESS CLIP,1.380LG .255ID	2
8	94762	SWITCH, IGNITION DELTA 7 TERM	1
9	327350	KEY,IGNITION GENERIC DELTA	1
11	57769	BULB, INDICATOR	2
12	94136	SWITCH LIMIT DELTA	2
13	94613	SOLENOID	1
14	710133	SCREW,HHWATAP 1/4X.50	2
15	710203	NUT, 1/4-20 HEXNYL 15X116	2
16	710228	WIRE, GROUND (24X32)	1
17	710133	SCREW, 1/4-20X.50	1
18	94159	SWITCH, SEAT	1
19	302257	BATTERY 12V 7 PLATE	1
20	710226	BOLT,1/4-20X.63CAR (2X82)	2
21	710225	NUT, WING 1/4-20 NC (14X79)	2

SCHEMATIC WIRING

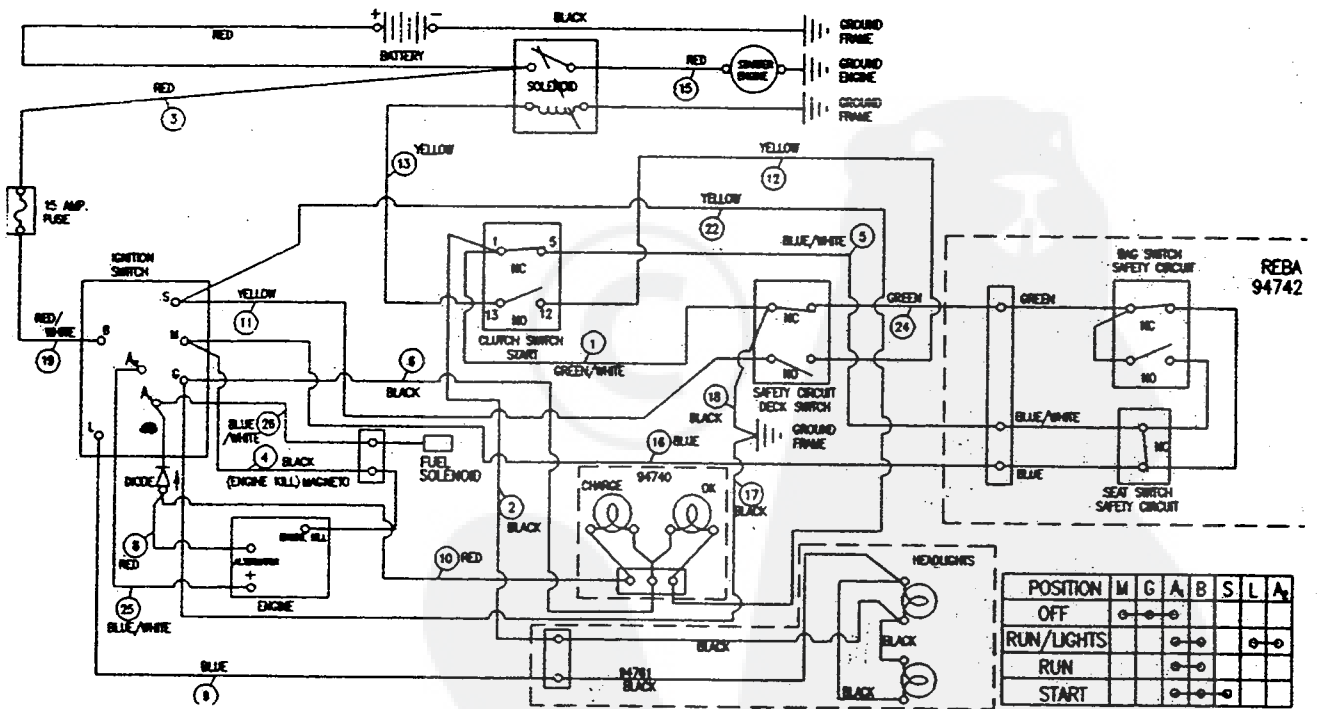

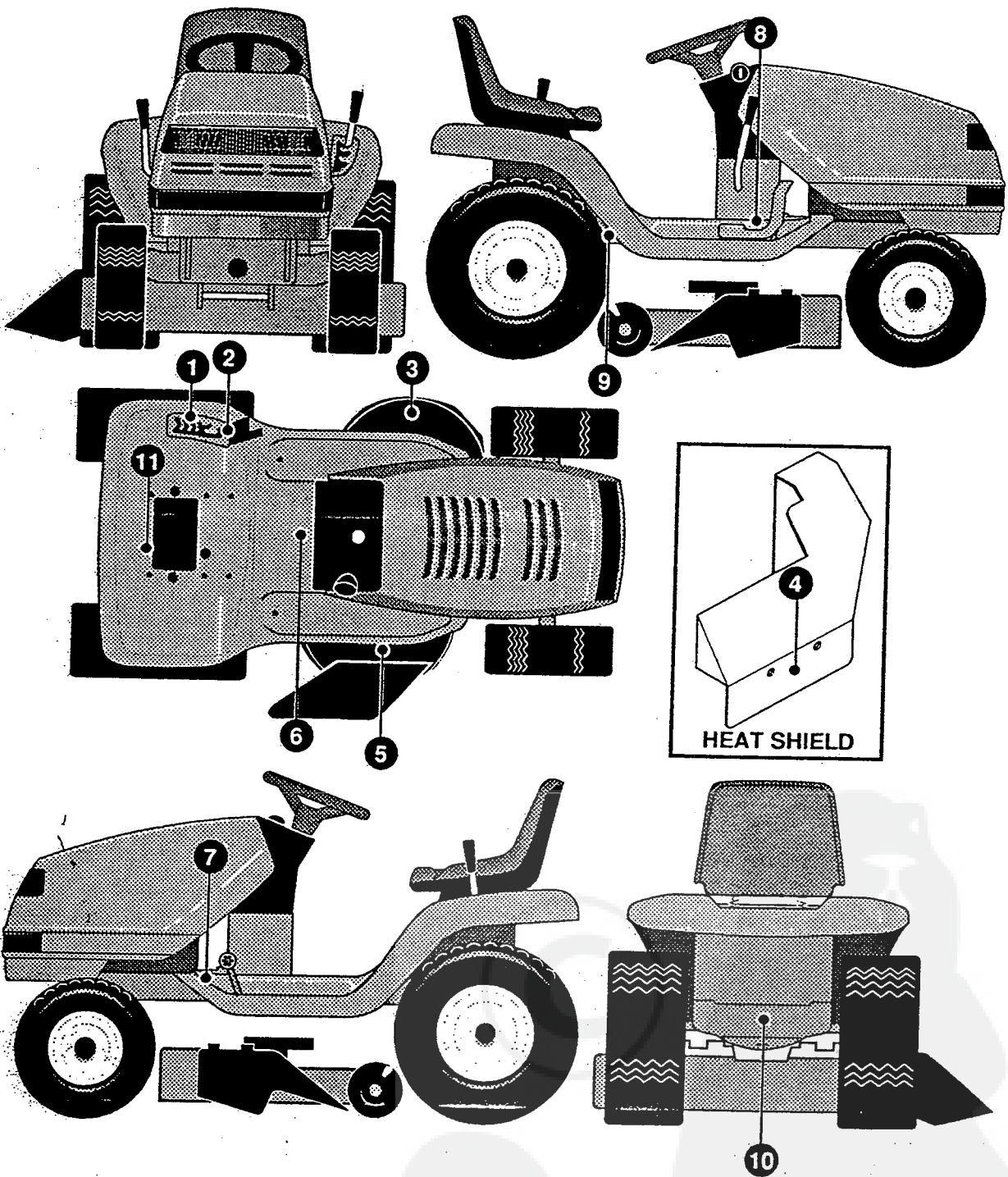

KEY NO.	PART NO.	DESCRIPTION	QTY
1	710723	DECAL, HEIGHT ADJUST	1
2	710683	DECAL, DECK LEVEL	1
3	402700	DECAL, CAUTION DECK LH	1
4	338543	DECAL, HOT SURF WARN M#44X5936	1
5	402701	DECAL, CAUTION DECK RH CUT HAND	1
6	710534	DECAL, CONS CAUT M#44X6815	1
7	402702	DECAL, BRAKE/CLUTCH PICTOGRAM	1
8	710720	DECAL, AUTODRIVE INSTR DASH	1
9	710523	DECAL, PINCH POINTS WARNING	1
10	338542	DECAL, DRAWBAR WARN M#44x6138	1
11	710767	DECAL, HYDRO PUMP EXPORT	1

341793A

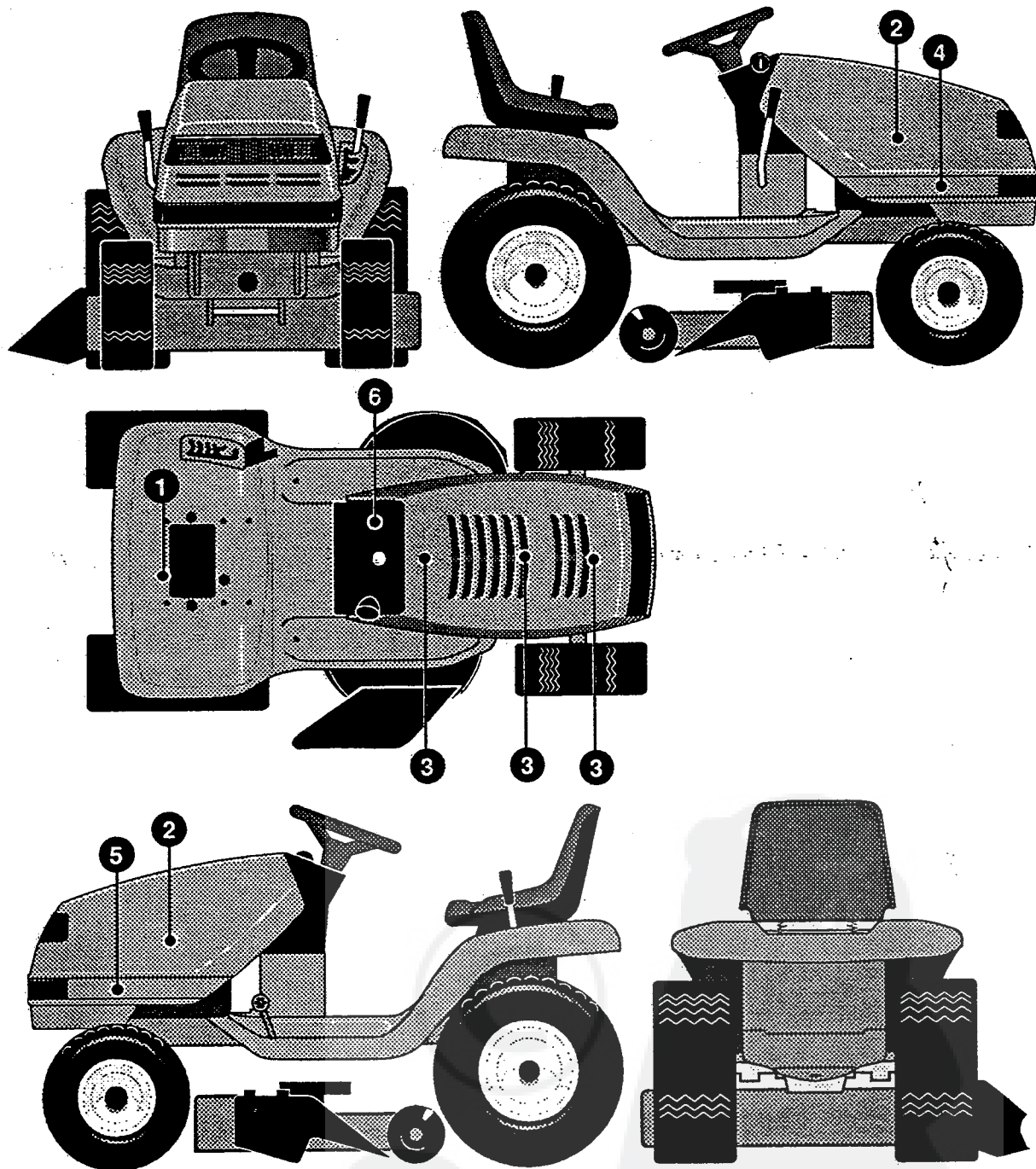

KEY NO.	PART NO.	DESCRIPTION	QTY
1		NOT A SERVICEABLE PART	
2	305603	PAD 18X6 FOAM HOOD	2
3	307277	PAD 12X4 FOAM HOOD	2
4	711016	DECAL, JARDIPRO RH	1
5	711017	DECAL, JARDIPRO LH	1
6	710427	DECAL, DASH W/CHOK	1

