

REPAIR PARTS MANUAL

36" - 12 H.P. RIDING MOWER

MODEL A3560-010

ONE YEAR LIMITED WARRANTY

For one (1) year from date of purchase by the first consumer for residential use (thirty (30) days commercial use), NOMA Outdoor Products Incorporated warrants that it will replace free of charge, including labor, any original part of any NOMA Outdoor Products Incorporated product found to be defective by any authorized Service Dealer or the factory, except the battery which is warranted for ninety (90) days from date of purchase.

This warranty does not cover engine, transmission, transaxle or differential (these items are covered by their manufacturer's own warranty). This warranty does not cover parts that have failed due to normal wear or parts that have failed subject to misuse or abuse. Transportation of the unit or part to and from an authorized Service Dealer or factory is the responsibility of the owner.

A step by step explanation as to what procedure should be followed for this warranty is:

1. If a part becomes defective, contact the store where the unit was purchased for the name and address of the authorized Service Dealer nearest to you.
2. If you cannot locate an authorized Service Dealer, write Service Department of NOMA Outdoor Products Incorporated for the name and address of the authorized Service Dealer in your area or call the Service Department at 1-801-422-1690.
3. Return the defective product, along with proof of purchase to such authorized Service Dealer for replacement of any defective part where covered by this warranty.

There is no other express warranty. Implied warranties, including those of merchantability and fitness for a particular purpose are limited to one (1) year from date of purchase. Liability for incidental or consequential damages are excluded.

Some states do not allow limitations on how long an implied warranty lasts, so the above limitation may not apply to you. Some states do not allow the exclusion of incidental or consequential damages, so the above exclusion may not apply to you. This warranty gives you specific legal rights, and you may have other rights which vary from state to state.

NOMA Outdoor Products Incorporated Caller 8000 Jackson, TN 38308-8000

UNIT PARTS AND SERVICE

This manual contains instructions for safety, assembly and maintenance. Read this manual carefully and completely so that you will know proper assembly, use and care of your unit. Also fill in and mail the registration card packed with the unit. For service other than covered in this manual, contact an authorized service dealer. A nationwide parts and service organization has been established to provide locally available parts and service. A list of authorized parts distributors has been included in this manual. When ordering repair parts, always give the following information: 1. The Part Name; 2. The Part Number; 3. The Quantity desired; 4. The Full (eight digit) Model Number of the unit. The model number will be found on a plate attached to the unit.

Look for this symbol.



It means - ATTENTION! BECOME ALERT! A HAZARD TO OPERATOR, BYSTANDER, PROPERTY OR EQUIPMENT MAY EXIST.

NOMA Outdoor Products Incorporated
Caller 8000

Part No. 310473

Jac. 901, TN 38308-8000

4199

Printed in U.S.A.

Price \$2.00
APR 16 01 7:51 NO.009 P.02

MURRAY SERVICE DEPT. ID:6153736798

p.1 01279726865

17 Apr 01 09:25 Anne Campbell



OPERATIONAL PRECAUTIONS



THESE INSTRUCTIONS ARE FOR YOUR PROTECTION. PLEASE READ THEM CAREFULLY.

1. Know the controls and how to stop quickly. READ THIS OPERATOR'S MANUAL and instructions furnished with attachments.
2. Wear safety glasses or eye shields when assembling or operating riding mower.
3. Do not allow children to operate the machine. Do not allow adults to operate it without proper instruction.
4. Do not carry passengers. Do not mow when children and others are around. Disengage power to blades(s) or attachment(s) and stop the engine while others are in the vicinity of the mower.
5. Battery fluid (electrolyte) is an ACID and is extremely dangerous. Do not smoke while servicing the battery. Do not service the battery near an open flame or spark.
6. Handle gasoline with care. It is highly flammable.
 - A. Use approved gasoline container.
 - B. Never remove the fuel cap of, or add gasoline to, a running or hot engine, or an engine that has not been allowed to cool for several minutes after running. Never fill the tank indoors and always clean up spilled fuel immediately.
 - C. Do not smoke while filling fuel tank.
 - D. Do not run the engine indoors. Open doors if engine must be run in garage. Exhaust fumes contain CARBON MONOXIDE, an ODORLESS and DEADLY GAS.
7. Check fuel supply before each use allowing space for expansion as the heat of the engine and/or sun can cause gasoline to expand.
8. Do not operate mower when barefooted. Always wear substantial footwear, preferably steel-toed shoes. Do not wear loose fitting clothing that could get caught in moving parts.
9. Clear the work area of objects (wire, rocks, etc.) which might be picked up and thrown. Check all controls for proper function.
10. Disengage all attachment clutches, shift to neutral, and set parking brake before attempting to start the engine (motor). When starting engine equipped with a pull starter, stand firm and make sure your feet are well away from the blade(s).
11. Disengage power to blade(s) or other attachment(s) and stop the engine (motor) before leaving the operator's position. Always dismount from the left side.
12. Disengage power to blade(s) or other attachment(s) and stop the engine (motor) before making any repairs or adjustments.
13. Disengage power to blade(s) or other attachment(s) when transporting or not in use.
14. Take all possible precautions when leaving the vehicle unattended, such as disengaging power to blade(s) or attachment(s), lower the attachment(s), setting the parking brake, stopping the engine (motor), and removing the key.
15. Do not stop or start suddenly when going uphill or downhill. Mow up and down the face of steep slopes; never across the face.
16. Reduce speed and exercise extreme caution on slopes and in sharp turns to prevent tipping or loss of control. Be especially cautious when changing direction on slopes.
17. Stay alert for holes, rocks, and roots in the terrain and other hidden hazards. Keep away from drop-off. Never operate your riding mower on wet or slippery grass or at a speed which could cause a skid. Exercise care when mowing around a fixed object to prevent the blade(s) from striking it. Never deliberately run over any foreign object.
18. Always disengage blade control lever before attempting to remove the mower from a hole or other obstruction.
19. Use care when pulling loads or using heavy equipment.
 - A. Use only approved drawbar hitch points.
 - B. Limit loads to those that you can safely control.
 - C. Do not turn sharply. Use care when backing.
 - D. Use counterweight(s), wheel weights or tire chains when suggested in attachment(s) instructions.
20. Watch for traffic when crossing or near roadways.
21. When using attachment(s), never direct discharge of material toward bystanders nor allow anyone near the vehicle while in operation.
22. Keep the vehicle and attachments in good operating condition, and keep safety devices in place and in working condition.
23. Keep all nuts, bolts, and screws tight to be sure the equipment is in safe working condition.
24. Never store the equipment with gasoline in the tank inside a building where fumes may reach an open flame or spark. Allow the engine to cool before storing in any enclosure.
25. To reduce fire hazard, keep the engine free of grass, leaves or excessive grease.
26. The vehicle and attachments should be stopped and inspected for damage after striking a foreign object, and the damage should be repaired before restarting and operating the equipment.
27. Do not change the engine governor settings or over-speed engine.
28. When using the vehicle with mower, proceed as follows:
 - A. Mow only in daylight or in good artificial light.
 - B. Never make a cutting height adjustment while the engine (motor) is running if the operator must dismount to do so.
 - C. Shut the engine (motor) off when removing the grass catcher or unclogging chute.
 - D. Check the blade mounting bolts for proper tightness at frequent intervals.
29. Under normal usage, the grass catcher bag material is subject to deterioration and wear. Check the bag frequently for deterioration and wear and replace worn bags. Check that replacement bags comply with the original manufacturer's recommendations or specifications.
30. Disengage power to mower before backing up. Do not mow in reverse unless absolutely necessary and then only after careful observation of the entire area behind the mower.

Part No. 3104-3

APR 16 01 2:51 PM '09 P.03

MURRAY SERVICE DEPT. ID:6153736298

p.2

01279226865

Anne Campbell

17 Apr 01 09:26

OWNER'S INFORMATION

Record the following information about your unit so that you will be able to provide it in case of loss or theft.

MODEL NUMBER: - (Enter complete 8 digit number from model plate on unit)

PURCHASE DATE: / / CODE NO.: SERIAL NO.:

DEALER'S NAME AND ADDRESS: _____

CITY: _____ STATE: _____ TELEPHONE: _____

CONTENTS OF SHIPPING CARTON

- 1 - 36 In. Riding Mower
- 1 - Operator's Manual
- 1 - Repair Parts Manual
- 1 - Engine Manual
- 1 - Steering Wheel
- 1 - Seat
- 1 - Battery
- 1 - Package Battery Acid
- 1 - Bag of Assembly Parts Containing:
 - 1 - Oil Drain Trough
 - 1 - Pivot Rod (chute deflector)
 - 1 - Rubber Strap (Battery Hold-Down)
 - 1 - Spring Pin (Steering Wheel)
- 1 - Bag of Battery Cable Installation Parts Containing:
 - 2 - 1/4 - 20 x 5/8 inch Hex Nuts
 - 2 - Split Lockwashers
 - 2 - 9/32 inch Flatwashers
- 1 - Bag of Seat Mounting Parts Containing:
 - 4 - 5/16 - 18 x 3/4 inch Hex Head Screws
 - 4 - 5/16 inch Split Lockwashers
 - 4 - 11/32 inch Flatwashers

HOW TO MEASURE SCREW SIZE (5/16 x 1 1/2 INCH)

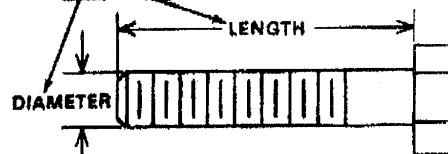

TOOLS REQUIRED FOR ASSEMBLY

- 1 - 7/16 inch Wrench (or adjustable wrench)
- 1 - 1/2 inch Wrench (or adjustable wrench)
- 1 - Hammer

⚠ DANGER ⚠

This riding mower can be dangerous if carelessly used.

Read your Owner's Manual thoroughly before operating your riding mower.

Always wear safety glasses or eye shields while assembling or operating your riding mower.

DO NOT carry passengers at any time.

Keep your hands, feet, hair and loose clothing away from the discharge area, the underside of the mower deck or any moving parts while the engine is running.

NOTICE

For packaging purposes, the knob may have been removed from the mower clutch lever and placed in the parts bag. Please screw the knob onto the mower clutch lever and tighten it securely.

For packaging purposes, the battery may have been installed on your unit. The battery must be removed from your machine to be serviced. See the Battery Removal paragraph in your Operator's Manual for removal instructions.

Part No. 310473 3
 APR 16 01 7:52 NO. 009 P. 04 MURRAY SERVICE DEPT. ID:6153736798

p. 3 17 Apr 01 09:26 Anne Campbell 01279726865

36" RIDING MOWER MODEL A3580-010

ALWAYS GIVE THE FOLLOWING INFORMATION WHEN ORDERING REPAIR PARTS:
1. The PART NUMBER; 2. The PART NAME; 3. QUANTITY DESIRED; 4. The MODEL NUMBER (As shown on Model Plate).

SEND PART ORDERS AS PER INSTRUCTIONS ON THE FRONT PAGE.

DO NOT USE KEY NUMBERS WHEN ORDERING REPAIR PARTS, ALWAYS USE PART NUMBERS.

All replacement parts will be supplied in current production colors or in a neutral color.

A handling fee is applicable to small parts orders.

YOUR UNIT IS RIGHT HAND (RH) OR LEFT HAND(LH) AS YOUR STAND BEHIND IT.

Key No.	Part No.	Description	Key No.	Part No.	Description
1	54873	Trough, Oil Drain	47	1489	Locknut, Hex, 3/8-18 Thd.
2	Engine	See Footnote Below	48	39859	Belt Retainer
3	302579	Gas Tank	49	43690	Rod, Clutch
4	47452	Gas Line	50	303031	Pulley, Idler
5	41008	Clamp, Gas Line	51	274517	Flatwasher, 13/32 In.
6	305409	Heat Shield, Muffler	52	1306	Idler Arm
7	46708	Gasket, Muffler	53	45892	Carriage Bolt, 3/8-16 x 1-1/2 In.
8	305406	Muffler	54	49276	Spring, Main Drive
9	Engine Part		55	4107	Washer, 5/8 In.
10	305407	Screw, Hex Hd, 5/16-18 Thd.	56	41890	Shoulder Bolt
11	303151	Key, Engine Pulley	57	22053	Retaining Ring
12	120393	Flatwasher, 11/32 In.	58	120228	Screw, Hex Hd, 5/16-18 x 5/8 In.
13	271184	Nut, Keps, 5/16-18 Thd.	59	7707	Bracket, Axle
14	271190	Nut, Keps, 3/8-16 Thd.	60	1498	Locknut, Hex 5/16-18 Thd.
15	138489	Washer, Pilot	61	138485	Washer, Ext. Lock, 5/16 In.
16	50947	Screw, Hex Wa Tap, 3/8-16 x 1-1/4 In.	62	55511	Ground Wire
17	50653	Belt Guide, Blade Drive	63	45602	Flatwasher, 21/64 In.
18	49896	Belt Guide, Transm. Drive Belt	64	310004	Foot Pad, R.H.
19	304330	Pulley Engine	65	310003	Foot Pad, L.H.
20	302445	Tube Shift	66	310300	Main Frame
21	120383	Lockwasher, Split, 7/16-In.	67	41529	Locknut, 3/8-16 Thd.
22	493146	Screw, Hex Hd, 7/16-20 x 4-1/4 In.	68	54880	Retainer, Wire
23	302283	Shift Lever	69	20507	Shoulder Bolt
24	304438	Knob, Gear Shift	70	54723	Bracket, Brake Rod
25	56255	Screw, Nylock, 1/4-28 x 3/4 In.	71	310189	Rod, Brake
26	57157	Washer	72	302600	Shaft, Brake-Clutch Pedal
27	56472	Deflector	73	121222	Pin, Cotter, 3/32 x 3/4 In.
28	57480	Shift Bracket	74	59979	Hubber Pad, Brake Pedal
29	137185	Cotter Pin, 1/8 x 1 In.	75	302603	Brake Pedal Assembly
30	41106	Wheel	76	50562	Spring, Clutch Pedal
31	24167	Valve Stem	77	20884	Retaining Ring
32	41106	Tire	78	302601	Spacer
33	39628	Key, 3/16 x 3/16 x 2-1/2 In.	79	120238	Jam Nut, Hex, 1/2-13 Thd.
34	180112	Screw, Hex Hd, 5/16-18 x 2-3/4 In.	80	309235	Fastner, Ratchet
35	Transaxle	Foot 4360-5 Speed	81	305410	Screw, Hex Hd, 1/4-20
36	35410	Spring, Brake Return.	82	58024	Wire Retainer
37	642	Flatwasher, 3/4 In.	83	302967	Speed Reducer
38	36625	E-Ring	84	35287	Screw, #8-32 x 3/8 In.
39	40394	Hub Cap	85	57479	Spacer
40	42815	Flatwasher, 3/4 In.	86	304246	Engine Pulley Spacer
41	35498	Screw, Hex Wa Tap, 5/16-18 x 3/4 In.	87	12583	Operator's Manual (Not Illustrated)
42	122017	Screw, Hex Hd, 5/16-18 x 1 In.	88	310473	Parts Manual, English (Not Illustrated)
43	309770	Bracket, Stabilizer			
44	54758	V-Belt			
45	302745	Pulley, Transaxle			
46	3021	Key, Woodruff, #606			

(*) Standard Hardware Items - May Be Purchased Locally

(-) Contact Engine Manufacturer's authorized service dealer (See Engine Manual) for parts and warranty.

(^) Contact Tecumseh/Peerless authorized service dealer for parts and warranty

APR 16 '01 7:53 No.009 P.06

MURRAY SERVICE DEPT. ID:61553736798

P.5

0127972685

Anne Campbell

17 Apr 01 09:28

RIDING MOWER MODEL A3560-010

NOTE: ALWAYS USE ORIGINAL EQUIPMENT PARTS. Use of service/replacement parts other than original equipment parts may void your warranty.

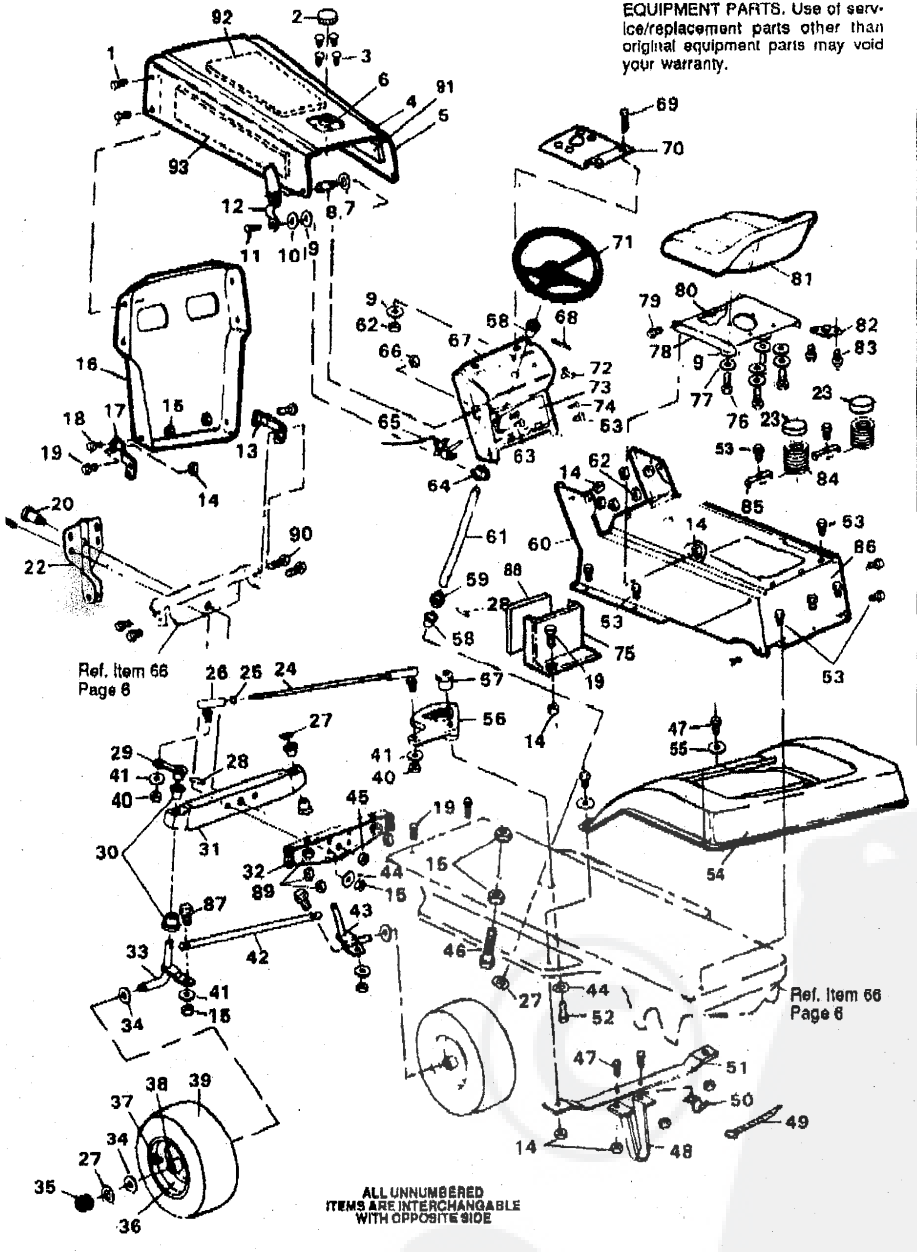

Part No. 310473

APR 16 '01 7:54 No.009 P.07

MURRAY SERVICE DEPT. ID:61537356798

P.6

01279726865

Anne Campbell

17 Apr 01 09:29

36" RIDING MOWER MODEL A3560-010

Key No.	Part No.	Description	Key No.	Part No.	Description
1	57215	Screw, Plastite, 5/16-9 x 3/4 In.	48	301258	Bracket, Deck Guide
2	46704	Gas Cap	49	57444	Tie Wire
3	49080	Screw, Plastite, 1/4-10 x 3/4 In.	50	57589	Retainer, Wire
4	7822	Hood	51	43964	Bracket, Deck Guide Support
5	59021	Edging, Hood	52	39573	Screw, Hex Hd, Lock, 3/8-24 x 1 In.
6	54885	Pad, Vibration	53	995346	Screw, Tapite, 1/4-20 x 1/2 In.
7	138538	Washer, Int. Lock	54	7219	Fender
8	53446	Pin, Hood Latch	55	446363	Flatwasher, 5/16 In.
9	120393	Flatwasher, 11/32 In.	56	304245	Sector Gear
10	120394	Flatwasher, 13/32-16 x 1 In.	57	44011	Shoulder Bolt, Sector Gear
11	8482	Shoulder Bolt	58	54902	Bearing, Steering
12	57159	Latch, Hood	59	44009	Pinion Gear
13	8535	Bracket, Grille Support, R.H.	60	310301	Console
14	1498	Locknut, Hex, 3/16-18 Thd.	61	44008	Shaft, Steering
15	1499	Locknut, 3/8-16 Thd.	62	1502	Locknut, Hex
16	56227	Grille	63	35287	Screw, Tapite, #8-32 x 3/8 In.
17	8533	Bracket, Grille Support, L.H.	64	39492	Retaining Ring
18	120233	Screw, Hex Hd, 3/8-16 x 1 In.	65	50117	Lever, Throttle Control
19	120228	Screw, Hex Hd, 5/16-18 x 5/8 In.	66	45174	Wide Flange Locknut
20	50720	Shoulder Bolt, Axle Pivot	67	8238	Dash
21	122201	Screw, Hex Hd, 3/8-16 x 2-3/4 In.	68	458378	Spring Pin, 1/4 x 2 In.
22	9140	Bracket, Deck Hanger	69	120854	Screw, Hex Hd, 1/4-20 x 5/8 In.
23	302099	Spring Covers	70	307674	Bracket, Support Fuel Tank
24	56190	Drag Link	71	301251	Steering Wheel
25	124925	Nut, Hex, 3/8-24 Thd.	72	50607	Knob, Throttle Control Lever
26	21275	Ball Joint	73	307022	Decal, Lower Dash
27	36825	E-Ring	74	274672	Screw, Hex Hd, 1/4-20 x 5/8 In.
28	454565	Roll Pin	75	8261	Bulkhead Assembly
29	49447	Arm, Steering	76	122007	Screw, Hex Hd, 5/16-18 x 3/4 In.
30	50546	Bearing, Spindle	77	120638	Lockwasher, Split, 5/16 In.
31	56400	Front Axle Assembly	78	304781	Plate, Seal
32	56362	Bracket, Front Axle Support	79	20507	Shoulder Bolt
33	302667	Spindle, Left	80	41482	Press Clip
34	842	Flatwasher, 3/4 In.	81	304318	Seat
35	49394	Hub Cap	82	57547	Switch, Seat
36	39829	Wheel w/Bearing	83	180505	Screw, 1/4-20 x 3/8 In.
37	24167	Valve Stem	84	58220	Spring Seat
38	39979	Bearing	85	1341	Clip, Seat Spring
39	301140	Tire	86	8521	Cover, Console, Rear
40	120369	Nut, Hex, 3/8-24 Thd.	87	122145	Screw, Hex Hd, 3/8-16 x 1-1/4 In.
41	120382	Lockwasher, Split, 3/8 In.	88	66538	Pad, Foam Console Bulkhead
42	302691	Tie Rod	89	55273	Locknut, Flange, 5/16-18 Thd.
43	302668	Spindle, Right	90	56030	Screw, Hex Hd, 5/16-18 x 3/4 In.
44	2483	Spring Washer	91	55834	Pad, Foam R.H.
45	274654	Locknut, Hex, 1/2-20 Thd.	92	55832	Pad, Foam Top
46	49930	Upstop Bolt	93	55833	Pad, Foam L.H.
47	122017	Screw, Hex Hd, 5/16-18 x 1 In.			

(*) Standard Hardware Items - May Be Purchased Locally

Part No. 310473

APR 16 01 7:55 NO. 009 P. 08

p. 7

01279726865

7

MURRAY SERVICE DEPT. ID:61537356798

17 Apr 01 09:30 Anne Campbell

36" RIDING MOWER MODEL A3560-010

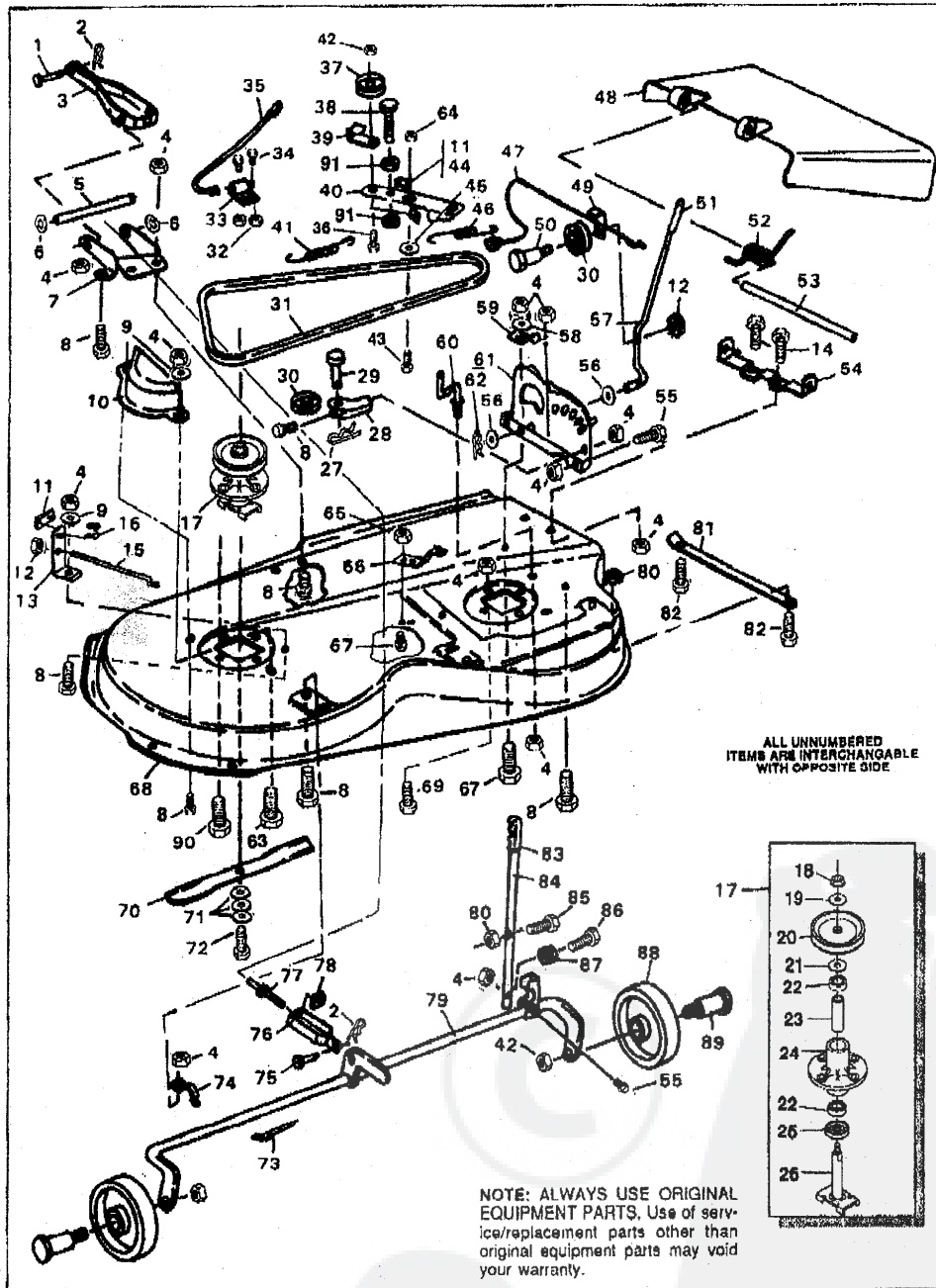

ALL UNNUMBERED
ITEMS ARE INTERCHANGEABLE
WITH OPPOSITE SIDE

NOTE: ALWAYS USE ORIGINAL
EQUIPMENT PARTS. Use of service/
replacement parts other than
original equipment parts may void
your warranty.

Part No. 3104/3

MURRAY SERVICE DEPT. ID:6153736798 APR 16 '01 7:55 No.009 P.09

17 Apr 01 09:31 Anne Campbell 01279726865 p.8

36" RIDING MOWER MODEL A3560-010

Key No.	Part No.	Description	Key No.	Part No.	Description
1	47818	Pin, Clevis	47	57326	Clutch Cable
2	56180	Pin, Hair	48	57818	Chute Guard
3	57340	Pivot Bracket	49	1288	Retainer, Cable
4	1498	Locknut, 5/16-18 Thd.	50	57322	Shoulder Bolt
5	57196	Pin, Pivot	51	46478	Grip, Clutch Lever
6	20864	"E" Ring	52	55767	Spring, Discharge Chute
7	57327	Lift Support Plate	53	57317	Rod, Pivot
8	120228	* Screw, Hex 5/16-18 x 5/8 In.	54	57380	Bracket, Pivot
9	120393	Flatwasher, 11/32 In.	55	122040	* Screw, Hex 5/16-18 x 1-1/2 In.
10	302893	Belt Guard, L.H. Pulley	56	120396	Washer, Flat
11	308973	Brake Pad	57	57329	Clutch Lever
12	1502	Locknut, 1/4-20 Thd.	58	120386	* Washer, Flat 5/16 In. I.D.
13	303247	Blade Brake Assy. (Incl. Nos. 11 & 16)	59	57321	Spring
14	120834	* Screw, Hex 5/16-18 x 1/2 In.	60	57318	Retainer, Bolt
15	300315	Rod, Brake Release	61	57337	Quadrant
16	135624	Rivet, Brake Pad	62	8260	Pin, Hair
17	56424	Quill Assy. (Incl. Nos. 18-26)	63	122017	Screw, Hex Hd 5/16-18 x 1 In.
18	1262	Locknut, Flange 7/16-20 Thd.	64	45171	* Locknut, Wide Flange 3/8-16 Thd.
19	56365	Special Washer	65	44108	Nut, Hex Wide Flange 5/16-18 Thd.
20	56390	Pulley	66	300179	Bracket, Idler
21	51449	Spacer, Quill	67	180077	* Screw, Hex Wide Flange 5/16-18 Thd.
22	49562	Bearing	68	305467	Mower Deck
23	50818	Spacer, Tube	69	300345	* Screw, Hex 5/16-18 x 1-3/8 In.
24	55547	Quill	70	56821	Blade
25	50616	Dust Shield	71	2483	Formed Washer
26	56425	Saddle & Shaft Assy.	72	39573	Screw, Hex 3/8-24 x 1 In.
27	121222	* Cotter Pin, 3/32 x 3/4 In.	73	57444	Wire Tie
28	49320	Support, Cable Pulley	74	51985	Support, Pivot Tube
29	49332	Pin, Clevis 3/8 x 1 In.	75	39522	Pin, Clevis
30	39295	Pulley, Nylon	76	9405	Clevis, Lift Cable
31	302289	V-Belt	77	300341	Lift, Cable
32	271166	Nut, Keps #10-24 Thd.	78	120372	* Nut, Square 1/4-20 Thd.
33	57478	Switch	79	306881	Pivot Tube Assembly
34	159943	Screw, Pan #10-24 x 5/8 In.	80	271184	* Nut, Keps 5/16-18 Thd.
35	57588	Wire Assembly	81	57314	Skid Bar
36	57325	Carriage Bolt, 3/8-16 x 2 In.	82	126216	* Carriage Bolt, 5/16-18 x 3/4 In.
37	303030	Pulley, Idler	83	56924	Grip, Height Adjust Lever
38	121954	* Screw, Hex 1/4-20 x 2 In.	84	300188	Height Adjust Lever
39	1346	Retainer, Belt	85	57324	Screw, Latch
40	300491	Idler Arm Assy. (Incl. Nos. 11 & 44)	86	995338	Screw, Tapite 1/4-20 x 5/8 In.
41	35410	Spring	87	57319	Spring
42	1499	Locknut, 3/8-16 Thd.	88	52584	Wheel, Deck
43	300180	Shoulder Bolt	89	23763	Wheel Axle
44	41601	Rivet, Brake Pad	90	50834	Screw, Hex Wa Tap 5/16-18 x 7/8 In.
45	996416	* Flatwasher, 3/8 In.	91	271172	Nut, Keps 1/4-20 Thd.
46	300883	Spring, Clutch			

(*) Standard Hardware Items - May Be Purchased Locally

36" RIDING MOWER MODEL A3580-010

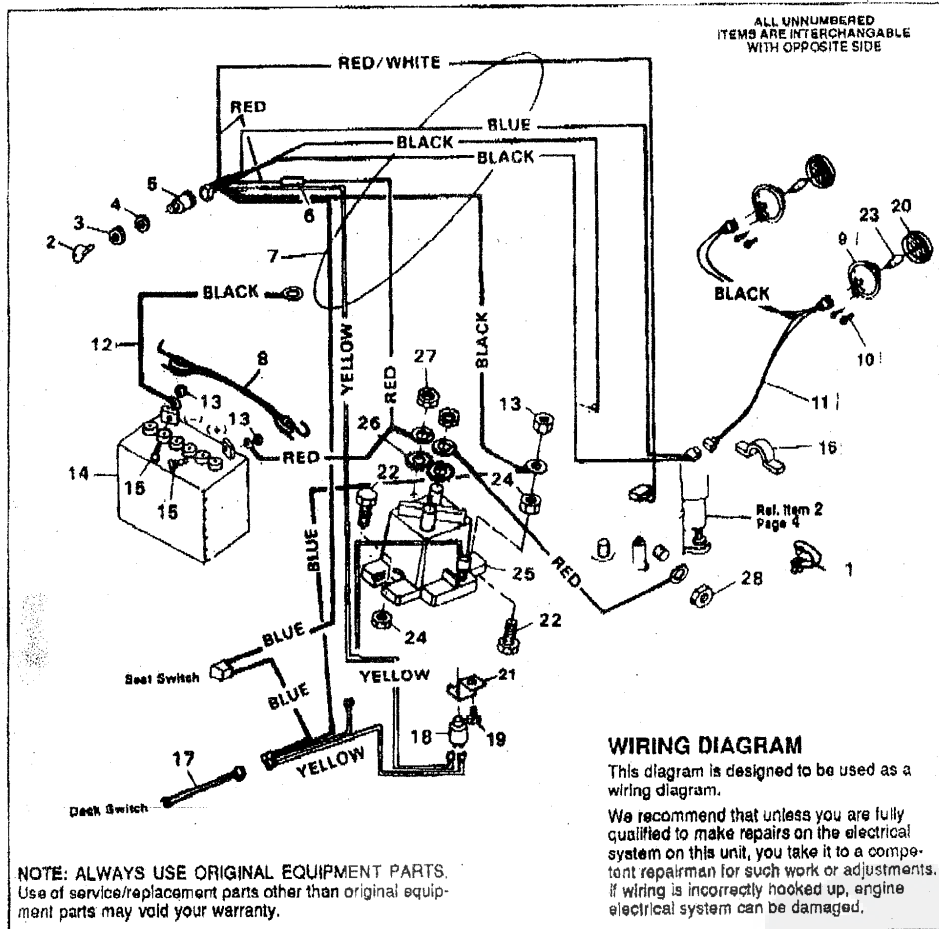

Key No.	Part No.	Description
1	54888	Wire Retainer
2	300626	Key, Ignition
3	48140	Locknut (Switch Part)
4	138557	Lockwasher (Switch Part)
5	300987	Switch, Ignition
6	302031	Fuse
7	57842	Wire Harness Assembly
8	309862	Strap, Rubber Battery Hold Down
9	52571	Bezel, Headlight
10	50868	Screw, Hex Wa Hd, #10-14 x 1/2 In.
11	56189	Lead Wire, Headlight
12	56511	Ground Wire
13	271172	Nut, Keps, 1/4-20 Thd.
14	302257	Battery
15	120854	Screw, Hex Hd, 1/4-20 x 5/8 In.

Key No.	Part No.	Description
16	41482	Wire Clip, Press
17	57588	Wire Assembly, Deck Switch
18	300220	Switch, Lockout
19	995346	Screw, Taplite, 1/4-20 x 1/2 In.
20	52570	Lens, Headlight
21	302610	Bracket, Switch Mounting
22	187745	Screw, Hex Hd, 1/4-20 x 3/4 In.
23	52572	Bulb, Headlight
24	1502	Locknut, Hex, 1/4-20 Thd.
25	53716	Solenoid
26	138485	Washer, Shakeproof, 5/16 In.
27	120388	Locknut, Hex, 5/16-24 Thd. Engine Part
28		

(*) Standard Hardware Items - May Be Purchased Locally

Part No. 310473

APR 16 2010 7:57 NO.009 P.11

MURRAY SERVICE DEPT. ID:6153736298

01279726865 P.10

17 Apr 01 09:32 Anne Campbell

ACCESSORIES

Contact the dealer where your tractor was purchased for the available accessories. If you are unable to contact the dealer, write to the address on the front cover of this manual.

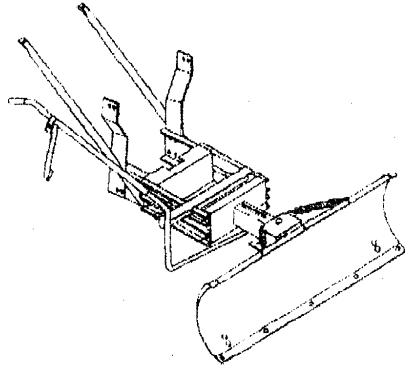

42" SNOW & GRADER BLADE

Rugged, heavy gauge steel blade. Spring loaded blade glides over uneven surfaces. Can be adjusted from seat for straight position, or 35 degrees left or right. Locks in raised position for traveling. Wheel and tire chains are recommended.

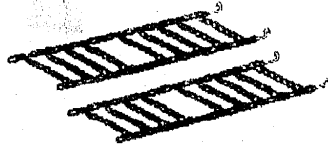

TIRE CHAINS

Tire chains for added traction are available. Specify tire size when ordering.

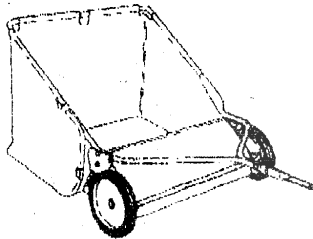

LAWN SWEEPER

Features extra heavy duty wheels and heavy duty basket. Basket is water, shrink and mildew proof with 6 bushel capacity. Dump release and height adjuster can both be operated from the tractor seat.

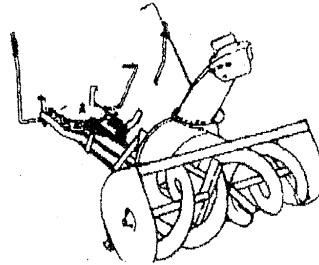

TWO STAGE SNOW THROWER

A powerful two stage snow thrower with a 1/4 inch second stage impeller capable of moving more than 70 tons of snow per hour and throwing it accurately in any direction you choose. Driver controlled discharge chute turns a 160 degree arc. Wheel weights and tire chains are recommended.

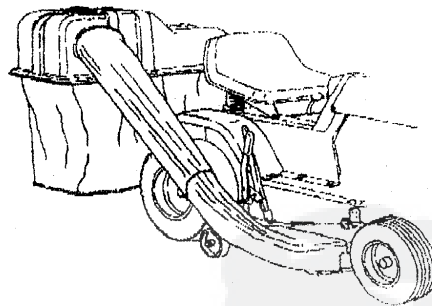

REAR MOUNT GRASS CATCHER

For 40-inch side discharge mower decks. Easy-On Easy-Off chute extension. Includes Easy-To-Dump twin grass collection containers with a 6-bushel capacity.

FRONT WHEEL WEIGHTS

One pair, 20 pounds each. Total weight 40 pounds. Includes mounting hardware.

REAR WHEEL WEIGHTS

One pair, 50 pounds each. Total weight 100 pounds. Includes mounting hardware.

Part No. 310473

APR 16 01 2:57 NO. 009 P. 12

P-11

01279726865

11

MURRAY SERVICE DEPT. ID:6153736798

Anne Campbell

17 Apr 01 09:33