

REPAIR PARTS MANUAL

36" - 12 H.P. RIDING MOWER

WITH GRASS COLLECTOR ATTACHMENT

MODEL A3560-120

ONE YEAR LIMITED WARRANTY

For one (1) year from date of purchase by the first consumer for residential use (thirty (30) days commercial use), NOMA Outdoor Products Incorporated warrants that it will replace free of charge, including labor, any original part of any NOMA Outdoor Products Incorporated product found to be defective by any authorized Service Dealer or the factory, except the battery which is warranted for ninety (90) days from date of purchase.

This warranty does not cover engine, transmission, transaxle or differential (these items are covered by their manufacturer's own warranty). This warranty does not cover parts that have failed due to normal wear or parts that have failed subject to misuse or abuse. Transportation of the unit or part to and from an authorized Service Dealer or factory is the responsibility of the owner.

A step by step explanation as to what procedure should be followed for this warranty is:

1. If a part becomes defective, contact the store where the unit was purchased for the name and address of the authorized Service Dealer nearest to you.
2. If you cannot locate an authorized Service Dealer, write Service Department of NOMA Outdoor Products Incorporated for the name and address of the authorized Service Dealer in your area or call the Service Department at 1-901-422-1690.
3. Return the defective product, along with proof of purchase to such authorized Service Dealer for replacement of any defective part where covered by this warranty.

There is no other express warranty. Implied warranties, including those of merchantability and fitness for a particular purpose are limited to one (1) year from date of purchase. Liability for incidental or consequential damages are excluded.

Some states do not allow limitations on how long an implied warranty lasts, so the above limitation may not apply to you. Some states do not allow the exclusion of incidental or consequential damages, so the above exclusion may not apply to you. This warranty gives you specific legal rights, and you may have other rights which vary from state to state.

NOMA Outdoor Products Incorporated

Caller 8000

Jackson, TN 38308-8000

UNIT PARTS AND SERVICE

This manual contains instructions for safety, assembly and maintenance. Read this manual carefully and completely so that you will know proper assembly, use and care of your unit. Also fill in and mail the registration card packed with the unit. For service other than covered in this manual, contact an authorized service dealer. A nationwide parts and service organization has been established to provide locally available parts and service. A list of authorized parts distributors has been included in this manual. When ordering repair parts, always give the following information: 1. The Part Name; 2. The Part Number; 3. The Quantity desired; 4. The Full (eight digit) Model Number of the unit. The model number will be found on a plate attached to the unit.



Look for this symbol.

It means - ATTENTION! BECOME ALERT! A HAZARD TO OPERATOR, BYSTANDER, PROPERTY OR EQUIPMENT MAY EXIST.

NOMA Outdoor Products Incorporated

Caller 8000

Jackson, TN 38308-8000

Part No. 312307

4189



OPERATIONAL PRECAUTIONS



THESE INSTRUCTIONS ARE FOR YOUR PROTECTION. PLEASE READ THEM CAREFULLY.

1. Know the controls and how to stop quickly. READ THIS OPERATOR'S MANUAL and instructions furnished with attachments.
2. Wear safety glasses or eye shields when assembling or operating riding mower.
3. Do not allow children to operate the machine. Do not allow adults to operate it without proper instruction.
4. Do not carry passengers. Do not mow when children and others are around. Disengage power to blade(s) or attachment(s) and stop the engine while others are in the vicinity of the mower.
5. Battery fluid (electrolyte) is an ACID and is extremely dangerous. Do not smoke while servicing the battery. Do not service the battery near an open flame or spark.
6. Handle gasoline with care, it is highly flammable.
 - A. Use approved gasoline container.
 - B. Never remove the fuel cap of, or add gasoline to, a running or hot engine, or an engine that has not been allowed to cool for several minutes after running. Never fill the tank indoors and always clean up spilled fuel immediately.
 - C. Do not smoke while filling fuel tank.
 - D. Do not run the engine indoors. Open doors if engine must be run in garage. Exhaust fumes contain CARBON MONOXIDE, an ODORLESS and DEADLY GAS.
7. Check fuel supply before each use allowing space for expansion as the heat of the engine and/or sun can cause gasoline to expand.
8. Do not operate mower when barefooted. Always wear substantial footwear, preferably steel-toed shoes. Do not wear loose fitting clothing that could get caught in moving parts.
9. Clear the work area of objects (wire, rocks, etc.) which might be picked up and thrown. Check all controls for proper function.
10. Disengage all attachment clutches, shift to neutral, and set parking brake before attempting to start the engine (motor). When starting engine equipped with a pull starter, stand firm and make sure your feet are well away from the blade(s).
11. Disengage power to blade(s) or other attachment(s) and stop the engine (motor) before leaving the operator's position. Always dismount from the left side.
12. Disengage power to blade(s) or other attachment(s) and stop the engine (motor) before making any repairs or adjustments.
13. Disengage power to blade(s) or other attachment(s) when transporting or not in use.
14. Take all possible precautions when leaving the vehicle unattended, such as disengaging power to blade(s) or attachment(s), lower the attachment(s), setting the parking brake, stopping the engine (motor), and removing the key.
15. Do not stop or start suddenly when going uphill or downhill. Mow up and down the face of steep slopes; never across the face.
16. Reduce speed and exercise extreme caution on slopes and in sharp turns to prevent tipping or loss of control. Be especially cautious when changing direction on slopes.
17. Stay alert for holes, rocks, and roots in the terrain and other hidden hazards. Keep away from drop-off. Never operate your riding mower on wet or slippery grass or at a speed which could cause a skid. Exercise care when mowing around a fixed object to prevent the blade(s) from striking it. Never deliberately run over any foreign object.
18. Always disengage blade control lever before attempting to remove the mower from a hole or other obstruction.
19. Use care when pulling loads or using heavy equipment.
 - A. Use only approved drawbar hitch points.
 - B. Limit loads to those that you can safely control.
 - C. Do not turn sharply. Use care when backing.
 - D. Use counterweight(s), wheel weights or tire chains when suggested in attachment(s) instructions.
20. Watch for traffic when crossing or near roadways.
21. When using attachment(s), never direct discharge of material toward bystanders nor allow anyone near the vehicle while in operation.
22. Keep the vehicle and attachments in good operating condition, and keep safety devices in place and in working condition.
23. Keep all nuts, bolts, and screws tight to be sure the equipment is in safe working condition.
24. Never store the equipment with gasoline in the tank inside a building where fumes may reach an open flame or spark. Allow the engine to cool before storing in any enclosure.
25. To reduce fire hazard, keep the engine free of grass, leaves or excessive grease.
26. The vehicle and attachments should be stopped and inspected for damage after striking a foreign object, and the damage should be repaired before restarting and operating the equipment.
27. Do not change the engine governor settings or over-speed engine.
28. When using the vehicle with mower, proceed as follows:
 - A. Mow only in daylight or in good artificial light.
 - B. Never make a cutting height adjustment while the engine (motor) is running if the operator must dismount to do so.
 - C. Shut the engine (motor) off when removing the grass catcher or unclogging chute.
 - D. Check the blade mounting bolts for proper tightness at frequent intervals.
29. Under normal usage, the grass catcher bag material is subject to deterioration and wear. Check the bag frequently for deterioration and wear and replace worn bags. Check that replacement bags comply with the original manufacturer's recommendations or specifications.
30. Disengage power to mower before backing up. Do not mow in reverse unless absolutely necessary and then only after careful observation of the entire area behind the mower.

OWNER'S INFORMATION

Record the following information about your unit so that you will be able to provide it in case of loss or theft.

MODEL NUMBER: - (Enter complete 8 digit number from model plate on unit)
PURCHASE DATE: ___ / ___ / ___ CODE NO.: _____ SERIAL NO.: _____
DEALER'S NAME AND ADDRESS: _____
CITY: _____ STATE: _____ TELEPHONE: _____

CONTENTS OF SHIPPING CARTON

- 1 - 36 In. Riding Mower
- 1 - Operator's Manual
- 1 - Repair Parts Manual
- 1 - Engine Manual
- 1 - Steering Wheel
- 1 - Seat
- 1 - Battery
- 1 - Bag of Assembly Parts Containing:
 - 1 - Oil Drain Trough
 - 1 - Pivot Rod (chute deflector)
 - 1 - Rubber Strap (Battery Hold-Down)
 - 1 - Spring Pin (Steering Wheel)
- 1 - Bag of Battery Cable Installation Parts Containing:
 - 2 - 1/4 - 20 x 5/8 Inch Hex Nuts
 - 2 - Split Lockwashers
 - 2 - 9/32 inch Flatwashers
- 1 - Bag of Seat Mounting Parts Containing:
 - 4 - 5/16 - 18 x 3/4 inch Hex Head Screws
 - 4 - 5/16 inch Split Lockwashers
 - 4 - 11/32 inch Flatwashers
- 1 - Bag of Grass Collector Assembly Parts Containing:
 - 3 - Cover Hinges
 - 1 - Latch Lever (chute)
 - 1 - Latch (cover)
 - 1 - Tab (chute latch lever)
 - 2 - Retainer Straps
 - 2 - Rubber Grommets
 - 6 - 1/4 x 5/8 Inch Round Head Screws
 - 2 - 1/4 x 3/4 inch Hex Head Screws
 - 4 - 5/16 x 1 inch Hex Head Screws
 - 1 - 5/16 x 1/2 inch 5/8 inch Hex Head Screws
 - 1 - 5/16 x 1/2 inch Self-Tap Screws
 - 6 - 1/4 inch Keps Nuts (star washer attached)
 - 2 - 1/4 inch Locknuts
 - 4 - 5/16 inch Wide Flange Locknuts
 - 1 - 5/16 inch Locknut
 - 2 - 9/32 inch Flatwashers
 - 2 - 5/16 inch Flatwashers

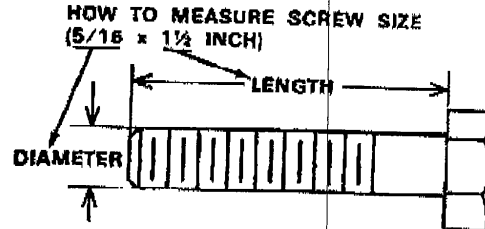

! DANGER !

This riding mower can be dangerous if carelessly used.

Read your Owner's Manual thoroughly before operating your riding mower.

Always wear safety glasses or eye shields while assembling or operating your riding mower.

DO NOT carry passengers at any time.

Keep your hands, feet, hair and loose clothing away from the discharge area, the underside of the mower deck or any moving parts while the engine is running.

NOTICE

For packaging purposes, the knob may have been removed from the mower clutch lever and placed in the parts bag. Please screw the knob onto the mower clutch lever and tighten it securely.

For packaging purposes, the battery may have been installed on your unit. The battery must be removed from your machine to be serviced. See the Battery Removal paragraph in your Operator's Manual for removal instructions.

TOOLS REQUIRED FOR ASSEMBLY

- 1 - 7/16 inch Wrench (or adjustable wrench)
- 1 - 1/2 inch Wrench (or adjustable wrench)
- 1 - Hammer

36" RIDING MOWER MODEL A3560-120

NOTE: ALWAYS USE ORIGINAL EQUIPMENT PARTS. Use of service/replacement parts other than original equipment parts may void your warranty.

ALL UNNUMBERED ITEMS ARE INTERCHANGABLE WITH OPPOSITE SIDE

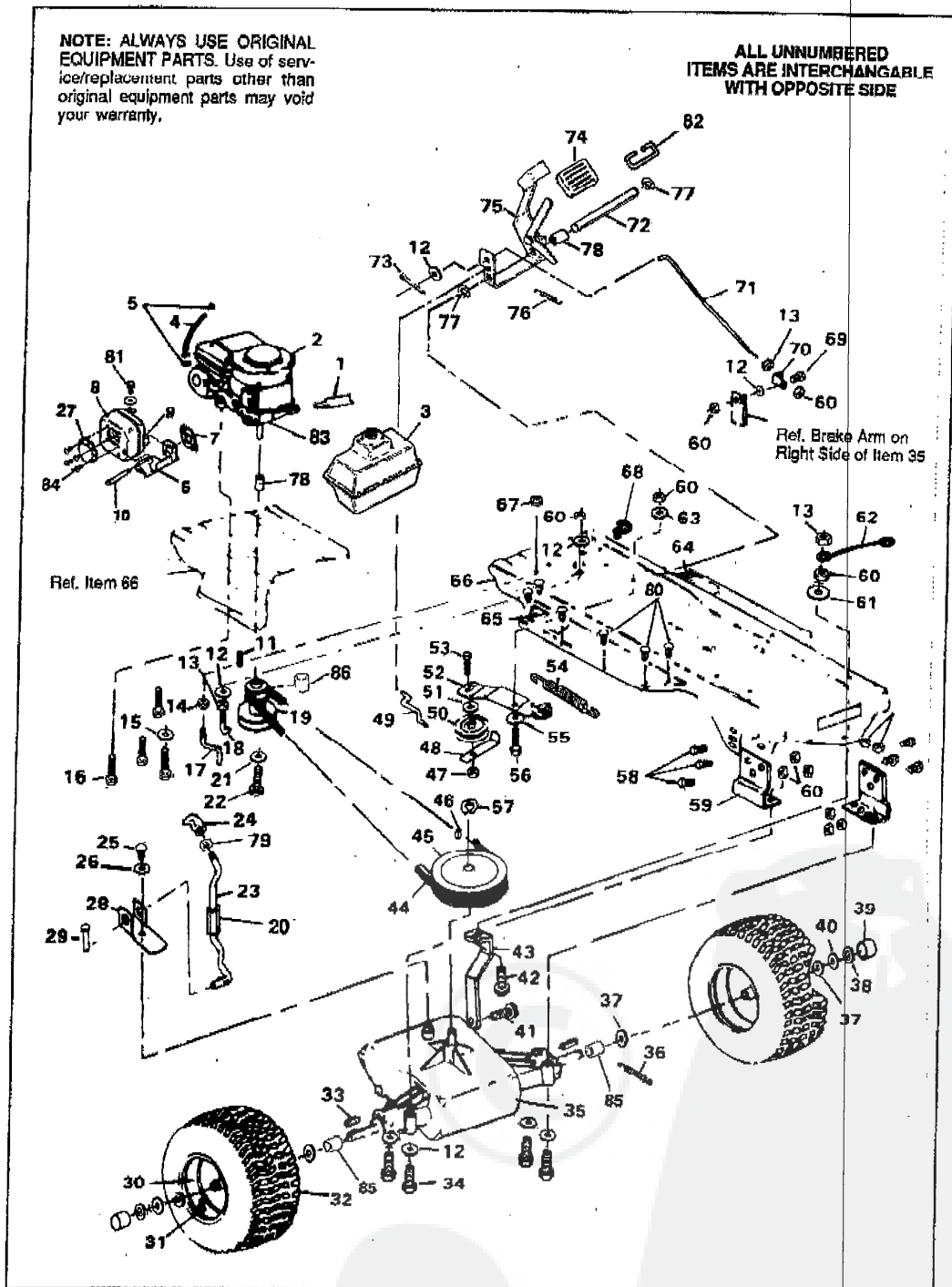

38" RIDING MOWER MODEL A3560-120

ALWAYS GIVE THE FOLLOWING INFORMATION WHEN ORDERING REPAIR PARTS:
 1. The PART NUMBER; 2. The PART NAME; 3. QUANTITY DESIRED; 4. The MODEL NUMBER (As shown on Model Plate).
 SEND PART ORDERS AS PER INSTRUCTIONS ON THE FRONT PAGE.
 DO NOT USE KEY NUMBERS WHEN ORDERING REPAIR PARTS, ALWAYS USE PART NUMBERS.
 All replacement parts will be supplied in current production colors or in a neutral color.
 A handling fee is applicable to small parts orders.
 YOUR UNIT IS RIGHT HAND (RH) OR LEFT HAND(LH) AS YOUR STAND BEHIND IT.

Key No.	Part No.	Description	Key No.	Part No.	Description
1	54873	Trough, Oil Drain	47	1499	Locknut, Hex, 3/8-16 Thd.
2	Engine	See Footnote Below	48	39859	Belt Retainer
3	302579	Gas Tank	49	43980	Rod, Clutch
4	47452	Gas Line	50	303031	Pulley, Idler
5	41008	Clamp, Gas Line	51	274517	Flatwasher, 13/32 In.
6	305409	Heat Shield, Muffler	52	1306	Killer Arm
7	46708	Gasket, Muffler	53	45892	Carriage Bolt, 3/8-16 x 1-1/2 In.
8	305408	Muffler	54	49276	Spring, Main Drive
9		Engine Part	55	4107	Washer, 5/8 In.
10	305407	* Screw, Hex Hd, 5/16-18 Thd.	56	41890	Shoulder Bolt
11	33200	Key, Engine Pulley	57	22053	Retaining Ring
12	120393	* Flatwasher, 11/32 In.	58	120228	* Screw, Hex Hd, 5/16-18 x 5/8 In.
13	271184	Nut, Keps, 5/16-18 Thd.	59	7707	Bracket, Axle
14	271190	Nut, Keps, 3/8-16 Thd.	60	1499	Locknut, Hex 5/16-18 Thd.
15	138489	Washer, Pilot	61	138485	Washer, Ext. Lock, 5/16 In.
16	50947	Screw, Hex Wa Tap, 3/8-16 x 1-1/4 In.	62	55511	Ground Wire
17	50653	Belt Guide, Blade Drive	63	45502	Flatwasher, 21/84 In.
18	49896	Belt Guide, Transm. Drive Belt	64	310004	Foot Pad, R.H.
19	304330	Pulley Engine	65	310003	Foot Pad, L.H.
20	302445	Tube Shift	66	310300	Main Frame
21	120363	* Lockwasher, Split, 7/16-In.	67	41529	Locknut, 3/8-16 Thd.
22	123567	Screw, Hex Hd, 7/16-20 x 1 In.	68	54888	Retainer, Wire
23	302283	Shift Lever	69	20507	Shoulder Bolt
24	304438	Knob, Gear Shift	70	54723	Bracket, Brake Rod
25	56255	Screw, Nylock, 1/4-28 x 3/4 In.	71	310189	Rod, Brake
26	57157	Washer	72	302600	Shaft, Brake-Clutch Pedal
27	56472	Deflector	73	121222	* Pin, Cotter, 3/32 x 3/4 In.
28	57480	Shift Bracket	74	53979	Rubber Pad, Brake Pedal
29	137185	* Cotter Pin, 1/8 x 1 In.	75	302603	Brake Pedal Assembly
30	41105	Wheel	76	50562	Spring, Clutch Pedal
31	24167	Valve Stem	77	20864	Retaining Ring
32	41106	Tire	78	302601	Spacer
33	39628	Key, 3/16 x 3/16 x 2-1/2 In.	79	120238	Jam Nut, Hex, 1/2-13 Thd.
34	180112	* Screw, Hex Hd, 5/16-18 x 2-3/4 In.	80	309235	Fastner, Ratchet
35	Transaxle	Footnote 4360-5 Speed	81	305410	Screw, Hex Hd, 1/4-20
36	35410	Spring, Brake Return.	82	55024	Wire Retainer
37	642	Flatwasher, 3/4 In.	83	302967	Speed Reducer
38	36626	E-Ring	84	35287	Screw, #8-32 x 3/8 In.
39	40394	Hub Cap	85	57479	Spacer
40	42815	Flatwasher, 3/4 In.	86	57479	Engine Pulley Spacer
41	35498	Screw, Hex Wa Tap, 5/16-18 x 3/4 In.	87	12563	Operator's Manual, English (Not Illustrated)
42	122017	* Screw, Hex Hd, 5/16-18 x 1 In.	88	312307	Parts Manual, English (Not Illustrated)
43	309770	Bracket, Stabilizer			
44	54758	V-Belt			
45	302745	Pulley, Transaxle			
46	3021	Key, Woodruff, #606			

(*) Standard Hardware Items - May Be Purchased Locally
 (-) Contact Engine Manufacturer's authorized service dealer (See Engine Manual) for parts and warranty.
 (A) Contact Tecumseh/Peerless authorized service dealer for parts and warranty

36" RIDING MOWER MODEL A3560-120

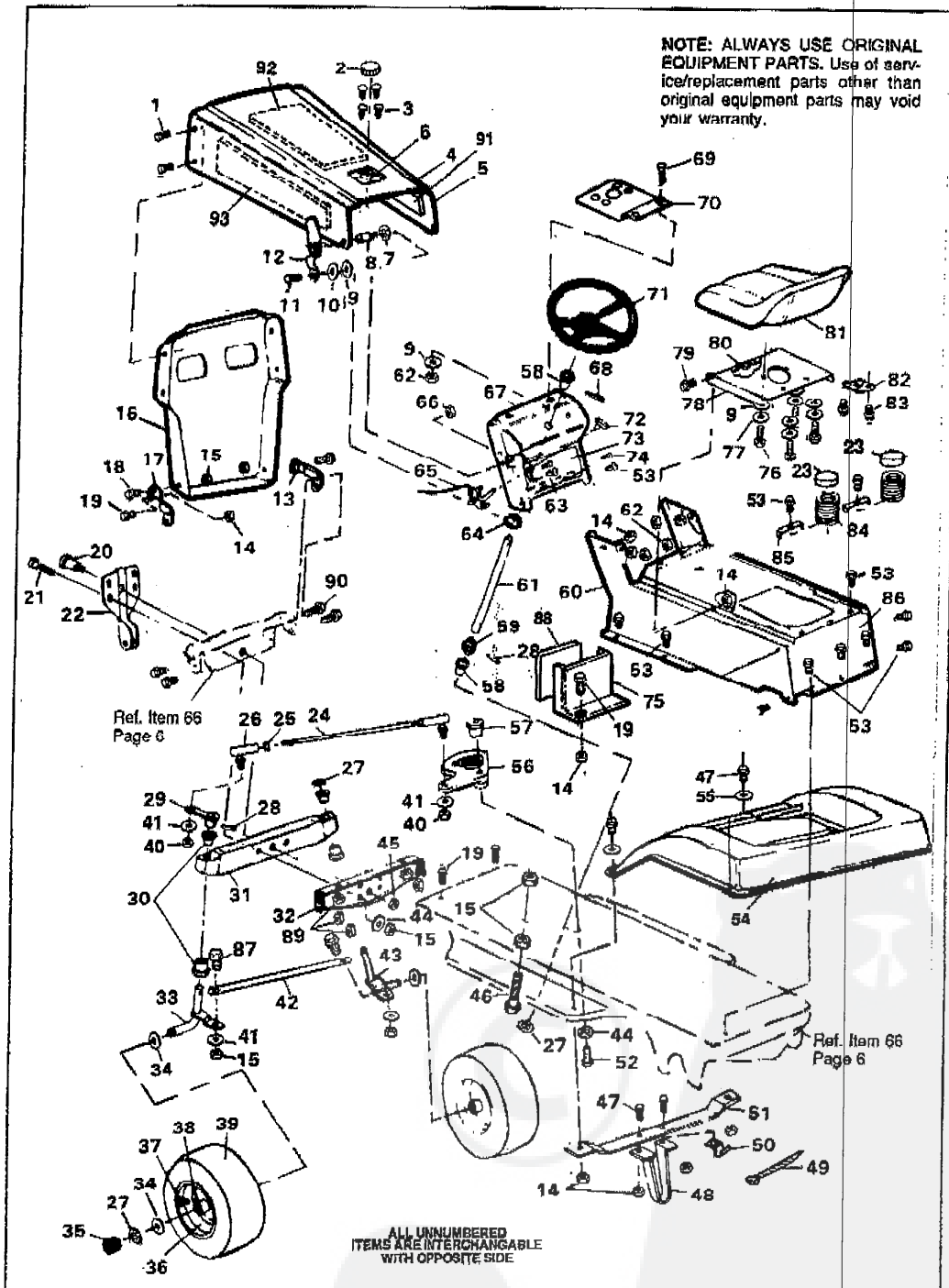

36" RIDING MOWER MODEL A3560-120

Key No.	Part No.	Description	Key No.	Part No.	Description
1	57215	Screw, Plastite, 5/16-9 x 3/4 In.	48	301258	Bracket, Deck Guide
2	48704	Gas Cap	49	57444	Tie Wire
3	49050	Screw, Plastite, 1/4-10 x 3/4 In.	50	57569	Retainer, Wire
4	7822	Hood	51	43964	Bracket, Deck Guide Support
5	55021	Edging, Hood	52	39573	Screw, Hex Hd, Lock, 3/8-24 x 1 In.
6	54885	Pad, Vibration	53	995346	* Screw, Tapitite, 1/4-20 x 1/2 In.
7	138538	Washer, Int. Lock	54	3606	Fender
8	53446	Pin, Hood Latch	55	446363	* Flatwasher, 3/8 In.
9	120393	* Flatwasher, 11/32 In.	56	304245	Sector Gear
10	120394	* Flatwasher, 13/32-16 x 1 In.	57	44011	Shoulder Bolt, Sector Gear
11	8482	Shoulder Bolt	58	54902	Bearing, Steering
12	57159	Latch, Hood	59	44009	Pinion Gear
13	8535	Bracket, Grille Support, R.H.	60	310301	Console
14	1498	Locknut, Hex, 5/16-18 Thd.	61	44008	Shaft, Steering
15	1499	Locknut, 3/8-16 Thd.	62	1502	Locknut, Hex
16	56227	Grille	63	35287	Screw, Tapitite, #8-32 x 3/8 In.
17	8533	Bracket, Grille Support, L.H.	64	39492	Retaining Ring
18	120233	* Screw, Hex Hd, 3/8-16 x 1 In.	65	50117	Lever, Throttle Control
19	120228	* Screw, Hex Hd, 5/16-18 x 5/8 In.	66	45174	Wide Flange Locknut
20	50720	Shoulder Bolt, Axle Pivot	67	8286	Dash
21	122201	* Screw, Hex Hd, 3/8-16 x 2-3/4 In.	68	456378	Spring Pin, 1/4 x 2 In.
22	9140	Bracket, Deck Hangar	69	120854	* Screw, Hex Hd, 1/4-20 x 5/8 In.
23	302099	Spring Covers	70	8147	Bracket, Support Fuel Tank
24	56190	Drag Link	71	301251	Steering Wheel
25	124925	Nut, Hex, 3/8-24 Thd.	72	50607	Knob, Throttle Control Lever
26	21275	Ball Joint	73	307022	Decal, Lower Dash
27	36625	E-Ring	74	274872	Screw, Hex Hd, 1/4-20 x 5/8 In.
28	454565	Roll Pin	75	6281	Bulkhead Assembly
29	49447	Arm, Steering	76	122007	* Screw, Hex Hd, 5/16-18 x 3/4 In.
30	50546	Bearing, Spindle	77	120638	* Lockwasher, Split, 5/16 In.
31	56400	Front Axle Assembly	78	304761	Plate, Seat
32	56362	Bracket, Front Axle Support	79	20507	Shoulder Bolt
33	302667	Spindia, Left	80	41482	Press Clip
34	642	Flatwasher, 3/4 In.	81	304316	Seat
35	40394	Hub Cap	82	57547	Switch, Seat
36	39829	Wheel w/Bearing	83	160505	Screw, 1/4-20 x 3/8 In.
37	24167	Valve Stem	84	56220	Spring Seat
38	39979	Bearing	85	1341	Clip, Seat Spring
39	301140	Tire	86	8521	Cover, Console, Rear
40	120369	* Nut, Hex, 3/8-24 Thd.	87	122145	* Screw, Hex Hd, 3/8-16 x 1-1/4 In.
41	120362	* Lockwasher, Split, 3/8 In.	88	55536	Pad, Foam Console Bulkhead
42	302691	Tie Rod	89	55273	Locknut, Flange, 5/16-18 Thd.
43	302668	Spindle, Right	90	56030	Screw, Hex Hd, 5/16-18 x 3/4 In.
44	2483	Spring Washer	91	55834	Pad, Foam R.H.
45	274854	Locknut, Hex, 1/2-20 Thd.	92	55832	Pad, Foam Top
46	49930	Upstop Bolt	93	55833	Pad, Foam L.H.
47	122017	* Screw, Hex Hd, 5/16-18 x 1 In.			

(*) Standard Hardware Items - May Be Purchased Locally

36" RIDING MOWER MODEL A3560-120

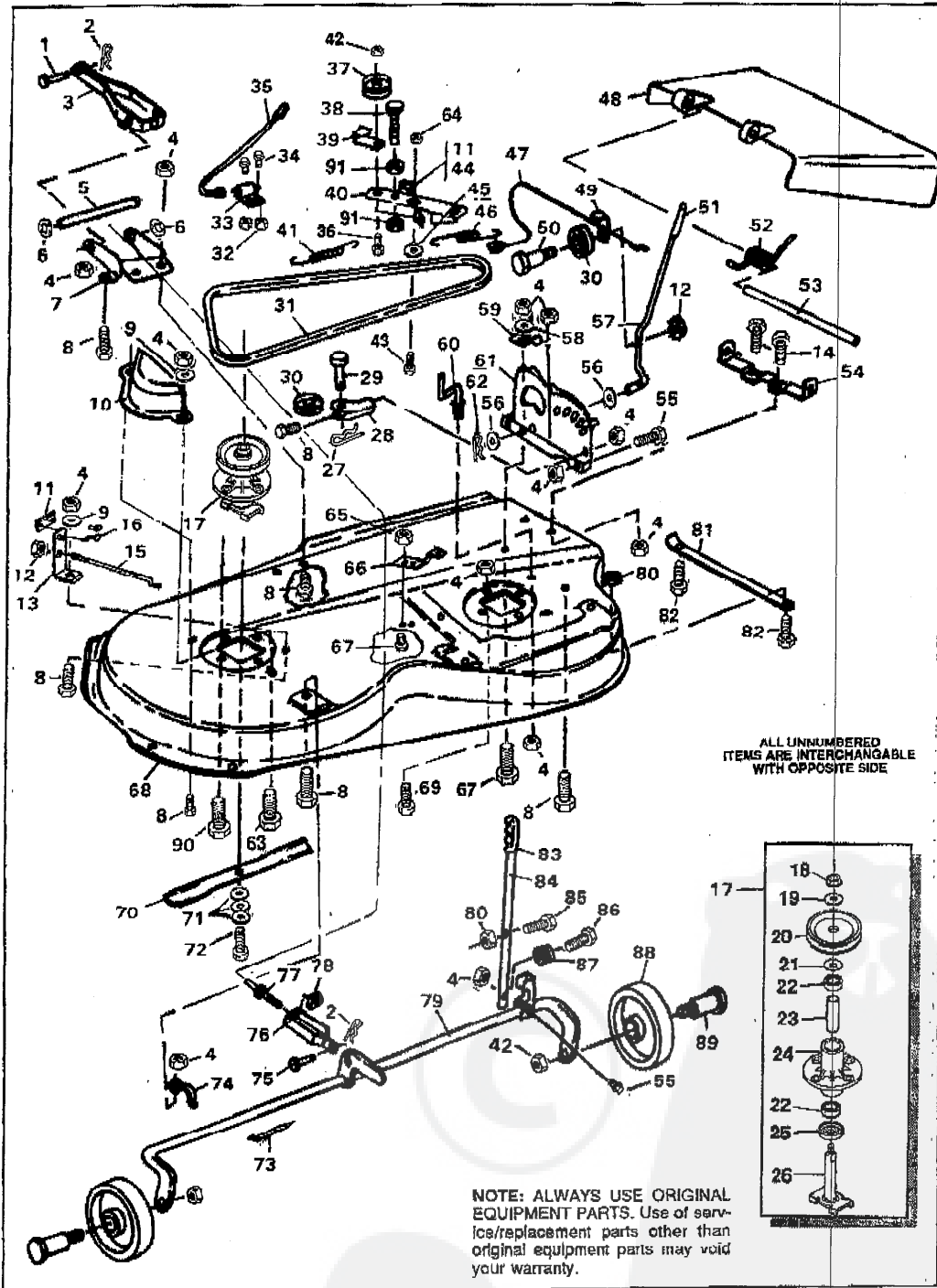

36" RIDING MOWER MODEL A356Q-120

Key No.	Part No.	Description	Key No.	Part No.	Description
1	47816	Pin, Clevis	47	57326	Clutch Cable
2	56180	Pin, Hair	48	57818	Chute Guard
3	57340	Pivot Bracket	49	1288	Retainer, Cable
4	1496	Locknut, 5/16-18 Thd.	50	57322	Shoulder Bolt
5	57196	Pin, Pivot	51	46478	Grip, Clutch Lever
6	20864	"E" Ring	52	55767	Spring, Discharge Chute
7	57327	Lift Support Plate	53	57317	Rod, Pivot
8	120228	* Screw, Hex 5/16-18 x 5/8 In.	54	57360	Bracket, Pivot
9	120393	Flatwasher, 1 1/32 In.	55	122040	* Screw, Hex 5/16-18 x 1-1/2 In.
10	302833	Belt Guard, L.H. Pulley	56	120396	Washer, Flat
11	306973	Brake Pad	57	57329	Clutch Lever
12	1502	Locknut, 1/4-20 Thd.	58	120386	* Washer, Flat 5/16 In. I.D.
13	303247	Blade Brake Assy. (Incl. Nos. 11 & 16)	59	57321	Spring
14	120834	* Screw, Hex 5/16-18 x 1/2 In.	60	57318	Retainer, Belt
15	300315	Rod, Brake Release	61	57337	Quadrant
16	135624	Rivet, Brake Pad	62	8260	Pin, Hair
17	56424	Quill Assy. (Incl. Nos. 18-26)	63	122017	Screw, Hex Hd 5/16-18 x 1 In.
18	1282	Locknut, Flange 7/16-20 Thd.	64	45171	* Locknut, Wide Flange 3/8-16 Thd.
19	56365	Special Washer	65	44108	Nut, Hex Wide Flange 5/16-18 Thd.
20	56390	Pulley	66	300179	Bracket, Idler
21	51449	Spacer, Quill	67	180077	* Screw, Hex Wide Flange 5/16-18 Thd.
22	49562	Bearing	68	305487	Mower Deck
23	50818	Spacer, Tube	69	300345	* Screw, Hex 5/16-18 x 1-3/8 In.
24	55547	Quill	70	56821	Blade
25	50816	Dust Shield	71	2483	Formed Washer
26	56425	Saddle & Shaft Assy.	72	39573	Screw, Hex 3/8-24 x 1 In.
27	121222	* Cotter Pin, 3/32 x 3/4 In.	73	57444	Wire Tie
28	49320	Support, Cable Pulley	74	51985	Support, Pivot Tube
29	49332	Pin, Clevis 3/8 x 1 In.	75	39522	Pin, Clevis
30	39298	Pulley, Nylon	76	9405	Clevis, Lift Cable
31	302289	V-Belt	77	300341	Lift, Cable
32	271166	Nut, Keps #10-24 Thd.	78	120372	* Nut, Square 1/4-20 Thd.
33	57476	Switch	79	306981	Pivot Tube Assembly
34	159943	Screw, Pan #10-24 x 5/8 In.	80	271184	* Nut, Keps 5/16-18 Thd.
35	57588	Wire Assembly	81	57314	Skid Bar
36	57325	Carriage Bolt, 3/8-16 x 2 In.	82	126216	* Carriage Bolt, 5/16-18 x 3/4 In.
37	303030	Pulley, Idler	83	56924	Grip, Height Adjust Lever
38	121954	* Screw, Hex 1/4-20 x 2 In.	84	300188	Height Adjust Lever
39	1346	Retainer, Belt	85	57324	Screw, Latch
40	300491	Idler Arm Assy. (Incl. Nos. 11 & 44)	86	995338	Screw, Tapite 1/4-20 x 5/8 In.
41	35410	Spring	87	57319	Spring
42	1499	Locknut, 3/8-16 Thd.	88	62584	Wheel, Deck
43	300180	Shoulder Bolt	89	23763	Wheel Axle
44	41601	Rivet, Brake Pad	90	50634	Screw, Hex Wa Tap 5/16-18 x 7/8 In.
45	996416	* Flatwasher, 3/8 In.	91	271172	Nut, Keps 1/4-20 Thd.
46	300683	Spring, Clutch			

(*) Standard Hardware Items - May Be Purchased Locally

36" RIDING MOWER MODEL A3560-120

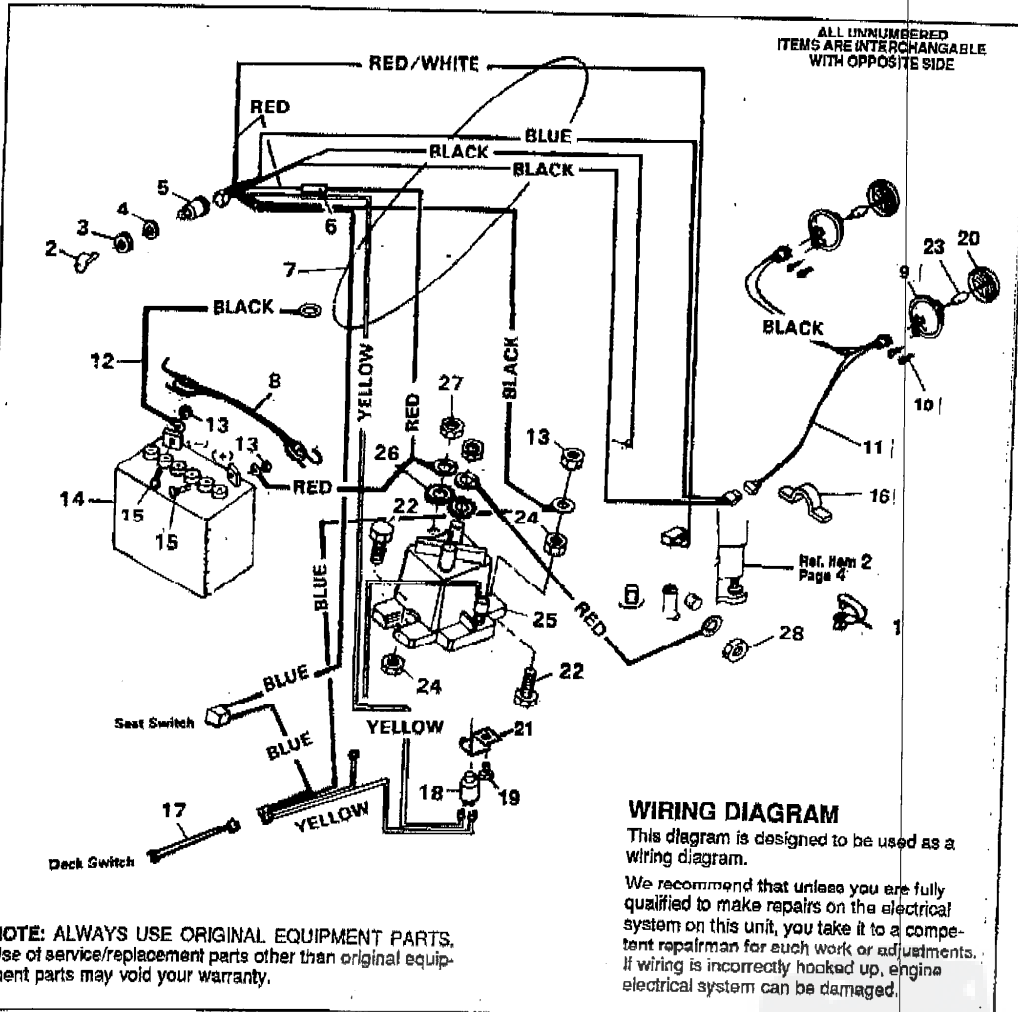

Key No.	Part No.	Description
1	54888	Wire Retainer
2	300626	Key, Ignition
3	48140	Locknut (Switch Part)
4	138557	Lockwasher (Switch Part)
5	300687	Switch, Ignition
6	302031	Fuse
7	57642	Wire Harness Assembly
8	309862	Strap, Rubber Battery Hold Down
9	52571	Bezel, Headlight
10	50668	Screw, Hex Wa Hd, #10-14 x 1/2 In.
11	58189	Lead Wire, Headlight
12	55511	Ground Wire
13	271172	Nut, Keys, 1/4-20 Thd.
14	302257	Battery
15	120854	* Screw, Hex Hd, 1/4-20 x 5/8 In.

Key No.	Part No.	Description
16	41482	Wire Clip, Press
17	57588	Wire Assembly, Deck Switch
18	300220	Switch, Lockout
19	995348	Screw, Taplite, 1/4-20 x 1/2 In.
20	52570	Lens, Headlight
21	302610	Bracket, Switch Mounting
22	187745	* Screw, Hex Hd, 1/4-20 x 3/4 In.
23	52572	Bulb, Headlight
24	1502	Locknut, Hex, 1/4-20 Thd.
25	53716	Solenoid
26	138485	* Washer, Shakeproof, 5/16 In.
27	120368	Locknut, Hex, 5/16-24 Thd.
28		Engine Part

(*) Standard Hardware Items - May Be Purchased Locally

39" RIDING MOWER MODEL A3560-120

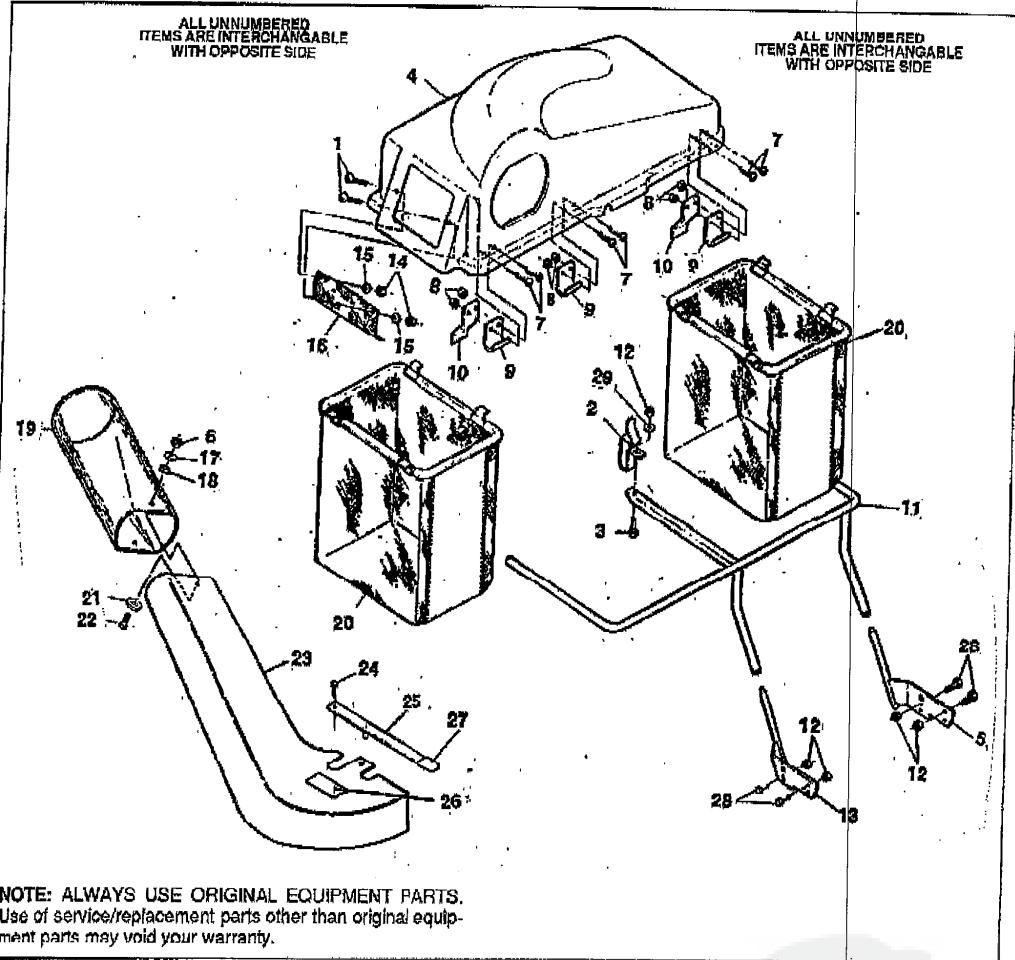

Key No.	Part No.	Description	Key No.	Part No.	Description
1	57034	Screw, SI Fl Hd, No. 10-24 x 5/8 In.	18	58283	Bag
2	12346	Latch, Bagger	19	120386	* Flatwasher, 5/16 In.
3	120393	* Flatwasher, 11/32 In.	20	180020	* Screw, Hex Hd, 1/4-20 x 3/4 In.
4	306944	Cover	21	57786	Chute, Transition
5	180076	* Screw, 5/16-18 x 5/8 In.	22	96487	Screw, Taptte, 5/16-18 x 1/2 In.
6	1498	Locknut, 5/16-18 Thd.	23	58320	Lever, Latch
7	55686	Screw, SI Rd Hd, 1/4-20 x 5/8 In.	24	306489	Decal, Transition Chute
8	271172	* Nut, Keps, 1/4-20 Thd.	25	42348	Tab
9	300278	Hinge, Cover	26	180079	* Screw, Hex Hd, 5/16-18 x 1 In.
10	300824	Retainer Strap	27	1347	Bracket Assy, Support Mount, R.H.
11	1253	Support Assembly	28	55273	Locknut, Wide Flange, 5/16-18 Thd.
12	271186	Nut, Keps, No. 10-24	29	1349	Bracket Assy, Support Mount, L.H.
13	1501	Flatwasher, 13/64 In.	30	306490	Decal, Cover
14	300116	Screen	31	306932	Blade, High Lift
15	57626	Flatwasher, 9/32 In.	32	1502	* Locknut, 1/4-20 Thd.
16	57506	Rubber Grommet	33	311216	Grass Catcher Manual (French)
17	57687	Upper Tube Assembly	34	306088	Grass Catcher Manual (English)

(* Standard Hardware Items - May Be Purchased Locally
 Part No. 312307

ACCESSORIES

Contact the dealer where your tractor was purchased for the available accessories. If you are unable to contact the dealer, write to the address on the front cover of this manual.

Rear Engine Rider

Model	Description
5708-16	Bagger - Fits 32" Side Discharge
5708-17	Bagger - Fits 38" Side Discharge
5709-02	Front Weight Box - holds 35 lbs.
5648-16	Lawn Sweeper w/dump Release

Lawn Tractor

Model	Description
5708-22	Bagger - Fits 30" Side Discharge
5708-13	Bagger - Fits 36", 38", 39" & 45" Side Discharge
5705-04	38" Two-Stage Snowblower - Fits 36", 38", 39", & 45" Side Discharge
5661-06	42" Snowblade - Fits 36", 38", 39", & 45"
5692-00	Tire Chains - 18" x 6.50"
5685-00	Tire Chains - 18" x 9.50" & 20" x 8"
5672-01	Wheel Weights - Front - 1 pr. w/mtg. hdw. - Fits 15" tires
5673-02	Wheel Weights - Rear - 1 pr. w/mtg. hdw. - Fits 18" & 20" tires
5709-03	Front Weights - Fits 30" & 32" Side Discharge
5648-16	Lawn Sweeper w/dump Release

Garden Tractor - Light Ground Engaging

Model	Description
5708-13	Bagger - Fits 36", 38", 39", & 45" Side Discharge
5705-04	38" Two-Stage Snowblower - Fits 36", 38", 39", & 45"
5661-06	42" Snowblade - Fits 36", 38", 39", & 45"
5672-01	Wheel Weights - Front - 1 pr. w/mtg. hdw. - Fits 15" tires
5673-02	Wheel Weights - Rear - 1 pr. w/mtg. hdw. - Fits 18" & 20" tires
5648-16	Lawn Sweeper w/dump Release
5667-02	Sleeve Hitch - w/lift bar - Fits 45"
5668-01	Adaptor (sleeve hitch) for use w/23" tires
5708-00	Tire Chains - 20" x 10"
5671-00	Tire Chains - 23" x 9.50"
5672-02	Wheel Weights - Front - 1 pr. w/mtg. hdw. Fits 18" tires
5673-00	Wheel Weights - Rear - 1 pr. w/mtg. hdw. Fits 23" tires
5674-01*	10" One Bottom Moldboard Plow
5675-01*	Cultivator - 7 row - Adj. 6" - 42" width
5676-01*	Disc Harrow - 8" & 11" disc - Adj. width & disc angle
5677-02*	Tiller - 5 H.P. Self-Powered - 28" width

Four Wheel Steer

Model	Description
5708-14	Bagger - Fits 40" & 46" Side Discharge
5705-05	42" One-Stage Snowblower - Fits 40" & 46"
5661-07	48" Snowblade - Fits 40" & 46"
5709-04	Rear Weight Box for 40" & 46"
5648-16	Lawn Sweeper w/dump Release
5705-00	Tire Chains 20" x 10"
5671-00	Tire Chains 23" x 9.50"
5672-02	Wheel Weights - Front - 1 pr. w/mtg. hdw. Fits 18" tires
5673-00	Wheel Weights - Rear - 1 pr. w/mtg. hdw. Fits 23" tires
5672-01	Wheel Weights - Front - 1 pr. w/mtg. hdw. Fits 15" tires
5673-02	Wheel Weights - Rear - 1 pr. w/mtg. hdw. Fits 18" & 20" tires

Four Wheel Steer Garden Tractor

Model	Description
5667-04	Sleeve Hitch - w/lift bar Fits 46"
5674-01*	10" One Bottom Moldboard Plow
5675-01*	Cultivator - 7 row - Adj. 6" - 42" width
5676-01*	Disc Harrow 8" & 11" Disc. Adj. width & disc angle
5677-02*	Tiller 5 H.P. Self-Powered - 28" width
5648-16	Lawn Sweeper w/dump Release

*Requires a sleeve hitch