

36" RIDING MOWER MODEL A3560-240

ALL UNNUMBERED
ITEMS ARE INTERCHANGEABLE
WITH OPPOSITE SIDE

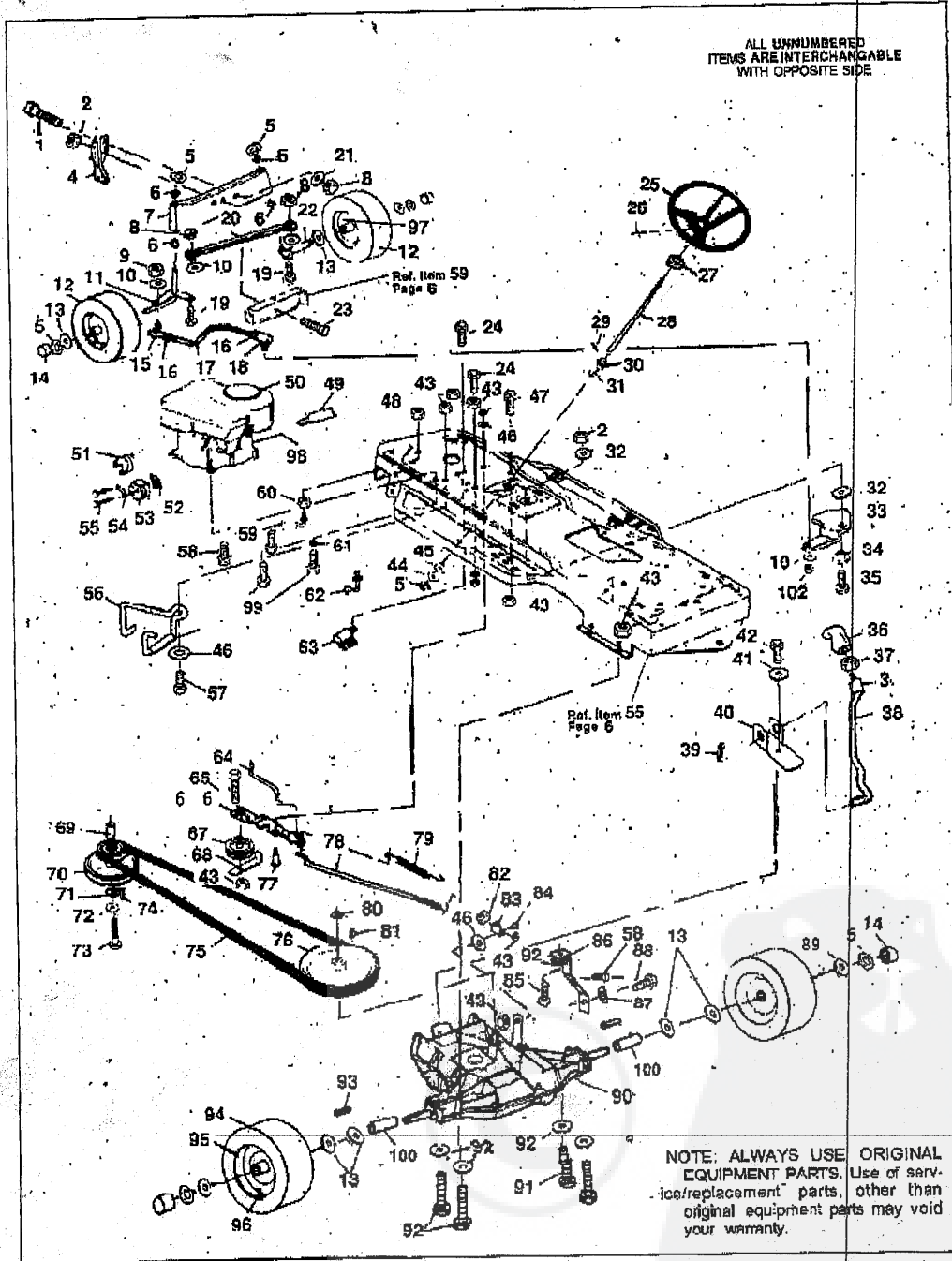

36" RIDING MOWER MODEL A3560-240

ALWAYS GIVE THE FOLLOWING INFORMATION WHEN ORDERING REPAIR PARTS:

1. The PART NUMBER, 2. The PART NAME, 3. QUANTITY DESIRED, 4. The MODEL NUMBER (As shown on Model Plate).

SEND PART ORDERS AS PER INSTRUCTIONS ON THE FRONT PAGE.

YOUR UNIT IS RIGHT HAND (RH) OR LEFT HAND (LH) AS YOU STAND BEHIND IT.

DO NOT USE KEY NUMBERS WHEN ORDERING REPAIR PARTS, ALWAYS USE PART NUMBERS.

All replacement parts will be supplied in current production colors or in a neutral color.
A handling fee is applicable to small parts orders.

Key No.	Part No.	Description	No.	Part No.	Description
1	122207	Screw, Hex Hd, 3/8-16 x 3 In.	57	180079	Screw, Hex Hd, 5/16-18 x 1 In.
2	1500	Locknut, 1/2-13 Thd.	58	50947	Screw, Taplts, 3/8-16 x 1-1/4 In.
3	302445	Shift Lever Tube	59	300635	Belt Guide
4	8775	Bracket, Deck Hanger	60	271190	Nut, Keps, 3/8-16 Thd.
5	36625	"E" Ring	81	138489	Star Washer
6	52407	Bearing, Front Spindle	62	300440	Belt Guide
7	55730	Front Axle	63	57476	Switch
8	1499	Locknut, 3/8-16 Thd.	64	57204	Rod, Clutch
10	120358	Lockwasher, Split, 3/8 In. Hd.	65	45892	Carriage Bolt, Rd Hd 3/8 x 1-1/2 In.
11	302925	Front Spindle, L.H.	66	300154	Idler Arm
12	301140	Front Tire	67	303031	Pulley, Idler
13	642	Flatwasher, 3/4 In.	68	30650	Belt Retainer
14b	40335	Ball Joint Hub Cap	69	304245	Spacer
16	124925	Nut, 3/8-24 Jam	70	306590	Pulley
17	58291	Steering Link	71	56431	Washer, Pilot
18	57158	Ball Joint	72	20383	Lockwasher, Split, 7/16 In.
19	180128	Screw, Hex Hd, 3/8-16 x 1-3/4 In.	73	428644	Screw, Hex Hd, 7/16-20 x 5 In.
20	304590	Tie Rod	74	57791	Key
21	2483	Spring Washer	75	57214	V-Belt
22	302.926	Front Spindle Assembly, R.H.	76	302745	Pulley
23	52428	Shoulder Bolt, Front Axle Pivot	77	300793	Shoulder Bolt
25	301251	Steering Wheel	78	57309	Brake Rod
26	456378	Roll Pin, 1/4 x 2 In.	79	56359	Spring, Clutch
27	301413	Cover, Steering Shaft	80	22053	Retaining Ring
28	58243	Shaft, Steering	81	3021	Key, Woodruff
29	58274	Pin, Dowel	82	271184	Nut, Keps, 5/16-18 Thd.
30	58244	Pinion, Steering	83	57217	Bracket, Brake, Rod
31			84	20507	Shoulder Bolt
32	301402285	Bushing Washer, 1/2 In.	85	122017	Screw, Hex Hd, 5/16-18 x 1 In.
33	50289	Sector Gear	86	12632	Stabilizing Bracket
34	52466	Eccentric	87	120939	Lockwasher, Split, 5/16 In.
35	180177	Screw, Hex Hd, 1/2-13 x 1-1/2 In.	88	35498	Screw, Taplts, 5/16-18 x 3/4 In.
36	304438	Knob Gear, Shift	89	42815	Flatwasher, 3/4 In.
37	120238	Jam Nut, 1/2-13 Thd.	90	Transaxle	Peerless, 400 cc 60-3
39	302788	Pin, Collar, 1/8 x 1 In. e r	91	180112	Screw, Hex Hd, 5/16-18 x 2-3/4 In.
40	57480	Shift Bracket	92	120393	Flatwasher, 1 1/32 In.
41	57157	Washer	93	20628	Key, 3/16 x 3/16 x 2-1/2 In.
42	56255	Screw, Hex Hd, 1/4-20 x 3/4 In.	94	41106	Tire, Rear
43	1498	Locknut, 5/16-18 In.	95	41105	Wheel, Rear
44	21682	Washer, 3/4 In.	96	24167	Valve Stem
45	301398	W a s h e r	97	39829	Wheel, Front
46	45602	Washer, 5/16 In.	98	302967	Engine Speed Reducer
47	120229	Screw, Hex Hd, 5/16-18 x 7/8 In.	99	50947	Screw, 3/8-16 x 1-1/4 Taplts.
48	124824	Jam Nut, 5/16 In.	100	57479	Spacer
49	54873	Trough, Oil Drain	101	303278	Plastic Extension
50	Engine	See Footnote Below	102	46892	Nut, 3/8-24 Hex Jam
51	54767	Heat Shield, Muffler	103	311696	Repair Parts Manual (English)
52	46708	Gasket, Muffler	104	12563	Operator's Manual (English)
53	305367	Muffler			
54	Engine Part				
55	173063	Screw, Hex Hd, 5/16-18 x 3-1/2 In.			
56	58356	Belt Guide			

(*) Standard Hardware Items - May Be Purchased Locally

(~) Contact Engine Manufacturer's authorized service dealer (See Engine Manual) for parts and warranty.

(^) Contact Tecumseh/Peerless authorized service dealer for parts and warranty

36" RIDING MOWER MODEL A3560-240

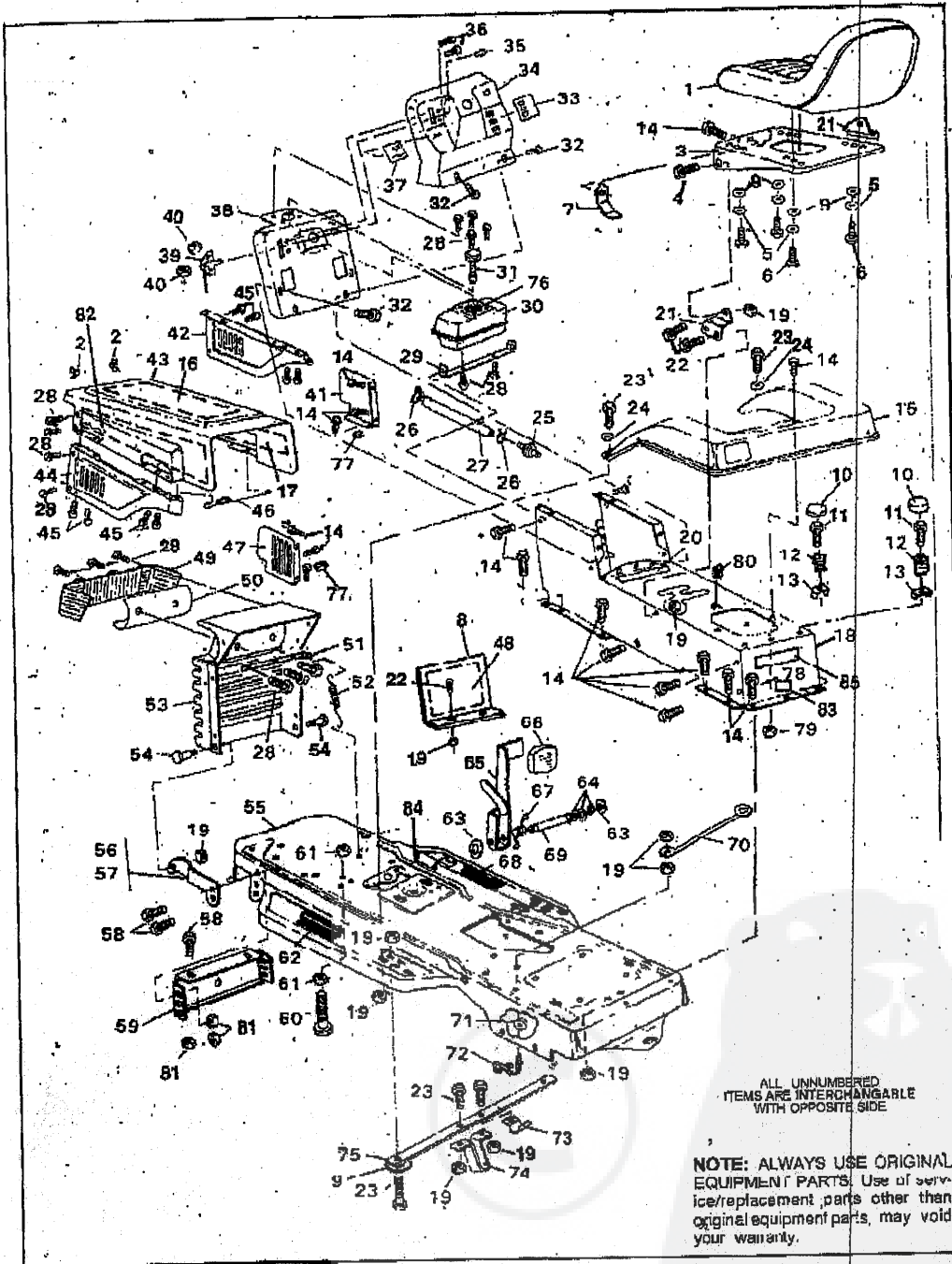

Part No. 311596

36" RIDING MOWER MODEL A3580-240

Key No.	Part No.	Description	Key No.	Part No.	Description
	301314	Seat	45	1503	Screw, Pan Hd. No. 10-16 x 1/2 in.
2	41482	Press Clip, Wire	46	57470	Spring, Hood
3	304761	Mounting Bracket, Seat	47	311735	Panel, Console Side, L.H.
4	20507	Shoulder Bolt	48	311697	Model Plate
5	120638	Lockwasher, Split, 5/16 in.	49	57473	Lens, Headlight
6	122007	Screw, Hex Hd, 5/16-18 x 3/4 in.	50	306965	Decal, Reflector, Grille
7	57476	Bracket, Seat Switch	51	9195	Bracket, Grille
8	57153	Spring, Seat	52	57478	Spring, Grille
9	120393	Flatwasher, 1 1/32 in.	53	303064	Grille
10	56907	Cover, Seat Spring	54	36149	Shoulder Bolt
11	44811	Screw, Tapite, 1/4-20 x 3/4 in.	55	310637	Main Frame
12	57153	Spring, Seat	56	12644	Bracket, Grille, R.H.
13	1341	Clamp, Seat Spring	57	12643	Bracket, Grille, L.H.
14	995348	Screw, Tapite, 1/4-20 x 1/2 in.	58	56030	Screw, Hex Hd, 5/16-18 x 3/4 in.
15	8782	Fender Assembly	59	56361	Bracket, Axle Support
16	302137	Fram, Hood, Top	60	49930	Rod, Upstop
17	302138	Foam, Hood, R.H.	61	1499	Locknut, 3/8-16 Thd.
18	311739	Console	62	310005	Foot Pad, L.H.
19	1499	Locknut, 5/16-18 Thd.	63	20864	Retaining Ring
20	69524	Decal, Caution	64	2968	Spacer
21	310444	Bracket, Seat Support	65	300308	Brake Pedal Assembly
22	120228	Screw, Hex Hd, 5/16-18 x 5/8 in.	66	52785	Pad, Brake Pedal
23	122017	Screw, Hex Hd, 5/16-18 x 1 in.	67	57847	Spring, Return
24	446363	Flatwasher, 3/8 in.	68	310006	Foot Pad, R.H.
25	Engine	Filter, Fuel	69	57196	Rod, Brake-Clutch
26	41008	Clamp, Fuel Line	70	55511	Ground Wire
27	47452	Tubing, Fuel Line	71	138538	Lockwasher, Int. Tooth, 5/16 in.
28	49050	Screw, Tapite, 1/4-20 x 3/4 in.	72	57259	Belt Guide
29	1208	Bracket, Fuel Tank	73	57569	Retainer, Wire
30	302579	Fuel Tank	74	44500	Guide, Rear Deck
31	46704	Gauge, Fuel Tank	75	43964	Bracket, Deck Guide Support
32	995338	Screw, Tapite, 1/4-20 x 5/8 in.	76	54895	Pad, Fuel Tank
33	311687	Decal, Dash, R.H.	77	58143	Clip
34	302104	Dash, Plastic Cover	78	35497	Screw, Hex W/a Hd, 5/16-18 x 1/2 in.
35	50607	Knob, Throttle Control	79	1502	Locknut, 1/4-20 Thd.
36	159943	Screw, Pan Hd, No. 10-24 x 5/8 in.	80	57547	Switch, Seat
37	311686	Decal, Dash, L.H.	81	65273	Locknut, 5/16-18 x 1/2 in.
38	1185	Dash, Metal	82	302139	Foam, Hood, L.H.
39	57768	Throttle Control	83	9664	Bulkhead
40	271166	Nut, Keps, No. 10-24 Thd.	84	120228	Screw, 5/16-18 x 5/8 in.
41	311734	Panel, Console Side, R.H.	85	55539	Foam Pad, Bulkhead Console
42	311736	Panel, Hood Side, R.H.			
43	311740	Hood			
44	311737	Panel, Hood Side, L.H.			

(*) Standard Hardware Items May Be Purchased Locally

36" RIDING MOWER MODEL A3560-240

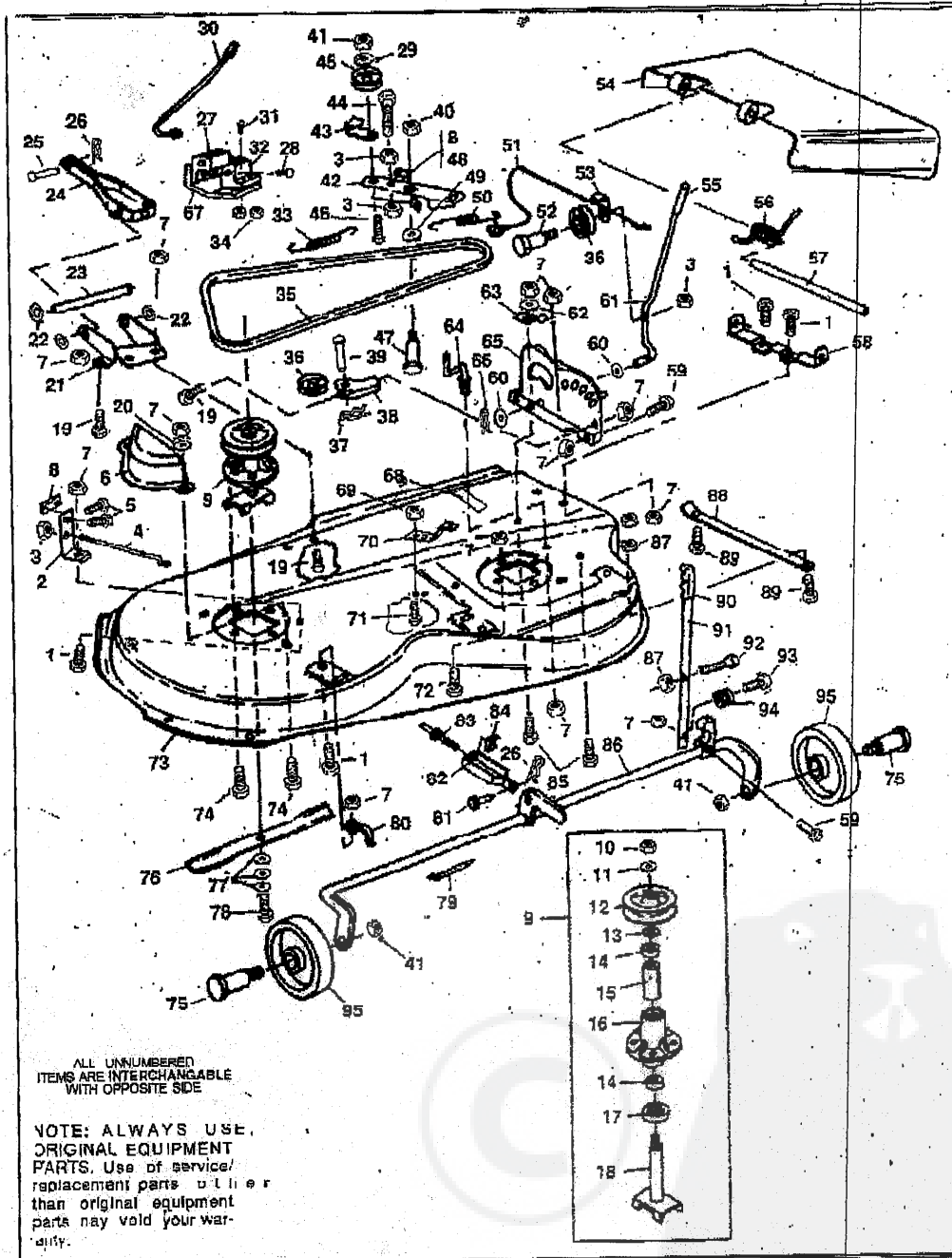

36" RIDING MOWER MODEL A3580-240

Key No.	Part No.	Description	Key No.	Part No.	Description
1	120834	* Screw, Hex Hd, 5/16-18 x 1/2 In.	49	996416	* Flatwasher, 3/8 In.
2	303247	Blade Bracket Assy. (Incl. 5 & 6)	50	300683	Spring, Clutch
3	1502	Locknut, 1 #20 Thd.	51	57326	Clutch Cable
4	300315	Rod, Brake Release	52	57322	Shoulder Bolt
5	135624	Rivet, Brake Pad	53	1288	Retainer Cable
6	302833	Belt Guard, L.H. Pulley	54	57818	Chute Guard
7	1498	Locknut, 5/16-18 Thd.	55	48478	Grip, Clutch Lever
8	306973	Brake Pad	56	55767	Spring, Discharge Chute
9	56424	Quill Assy. (Incl. 1 O-18)	5	57317	Rod, Pivot
10	1282	Locknut, Flange	58	57360	Bracket, Pivot
11	56385	Flatwasher	59	122040	Screw, Hex Hd, 5/16-18 x 1 1/2 In.
12	56390	Pulley, Quill	60	120396	Flatwasher
13	51449	Spacer	61	300188	Clutch Lever
14	49562	Bearing	62	120386	Flatwasher, 5/8 In.
15	50818	Spacer, Tube	63	57321	Spring
16	55547	Quill Casting	64	57318	Retainer, Belt
17	50616	Dust Shield, Quill	65	57337	Quadrant, Height Adjust
18	56425	Saddle & Shaft	68	58268	Blade Bracket
19	120228	* Screw, Hex Hd, 5/16-18 x 5/8 In.	68	68901	Decal, Height Adjustment
20	120393	* Flatwasher, 1 1/32 In.	69	44108	Nut, Hex, Wide Flange, 5/16-18 Thd.
21	57327	Lift Support Plate	70	300179	Bracket, Idler
22	20864	"E" Ring	71	180077	* Screw, Hex Hd, 5/16-18 x 3/4 In.
23	57196	Pin, Pivot	72	300345	* Screw, Hex Hd, 5/16-18 x 1-3/8 In.
24	57340	Pivot Bracket	73	305467	Mower Deck
25	47816	Pin, Clevis	74	50834	Screw, Hex Hd, 5/16-18 x 7/8 In.
26	58180	Hairpin Cutter	75	23763	Wheel, Axle
27	57916	Switch	76	58821	Blade
28	1503	Screw, Pan Hd. No. 10-18 x 1/2 In.	77	2483	Formed Washer
29	120382	Washer	78	39573	Screw, Hex Hd, 3/8-24 x 1 In.
30	57475	Wire Assembly	79	57444	Wire Tie
31	159943	Screw, Pan Hd. No. 10-24 x 5/8 In.	80	61985	Support, Pivot Tube
32	57476	Switch	82	39809	Clevis, Lift
33	35410	Spring	83	300341	Lift Cable
34	271166	Nut, Keps, No. 10-24-Thd.	84	120372	Nut, Square, 1/4-20 Thd.
35	302289	V-Belt	85	122007	* Screw, Hex Hd, 5/16-18 x 3/4 In.
36	39298	Pulley, Nylon	86	306881	Pivot Tube
37	121222	Cotter Pin, 3/32 x 3/14 In.	87	271184	Nut, Keps, 5/16-18 Thd.
38	49320	Support, Cable Pulley	88	57314	Skid Bar
39	49332	Pin, 3/8 x 1 In.	89	120216	Carriage Bolt, 5/16-18 x 3/4 In.
40	45171	Locknut, Wide Flange, 3/8-16 Thd.	90	56924	A Dipu Height Lever
41	1499	Locknut, 3/8-16 Hex.	91	57329	Height Adjust Lever
42	300491	Idler Arm Assy. (Incl. 8 & 48)	92	57324	Screw, Latch
43	1346	Retainer, Belt	93	995338	Screw, Tapite, 1/4-20 x 5/8 In.
44	121954	Screw, Hex Hd. 1/4-20 x 2 In.	94	57319	Spring
45	303030	Pulley, Idler	95	52584	Wheel, Deck
46	57325	Carriage Bolt, 3/8-16 x 2 In.			
47	300180	Shoulder Bolt			
48	41601	Rivet, Brake Pad			

(*) Standard Hardware Items - May Be Purchased Locally

36" RIDING MOWER MODEL A3650-240

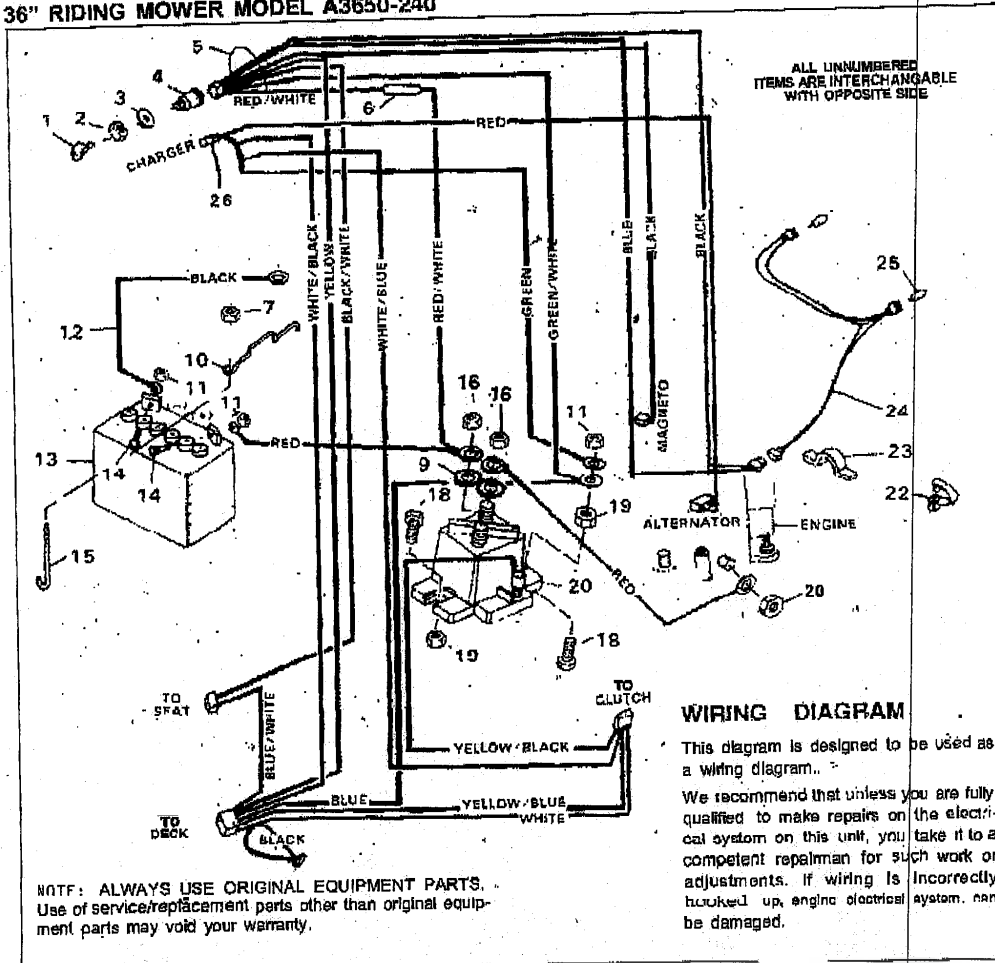

Key No.	Part No.	Description	Key No.	Part No.	Description
1	300826	Key, Ignition	14	120854	* Carriage Bolt, 1/4-20 x 5/8 In.
2	48140	Locknut (Switch Part)	15	57552	Bracket, Battery, Hold-Down
3	138557	Lockwasher (Switch Part)	16	128368	* Nut, Hex, 5/16-24 Thd.
4	300687	Switch, Ignition	17	138485	* Washer, Ext., Shakeproof, 5/16 In.
5	57475	Wire Harness Assembly	18	187745	* Screw, Hex Hd, 1/4-20 x 3/4 In.
6	302031	F u s e	19	1582	Locknut, Hex, 1/4-20 Thd.
7	518067	* Wing Nut, 1/4-20	20	53716	Solenoid
8	305401	Wire Assembly, Seat Switch	21		Engine Part
9	305511	Connector Body	22	308811	Retainer Wire
10	57551	Battery Rod	23	41482	Wire Clip, Press
11	271172	* Nut, Keys, 1/4-20 Thd.	24	303064	Lead Wire, Headlight
12	55611	Ground Wire,	25	52572	Bulb, Headlight
13	302257	Battery	26	57769	Bulb, Indicator

(* Standard Hardware Items - May Be Purchased Locally)

ACCESSORIES

Contact the dealer where your tractor was purchased for the available accessories. If you are unable to contact the dealer, write to the address on the front cover of this manual.

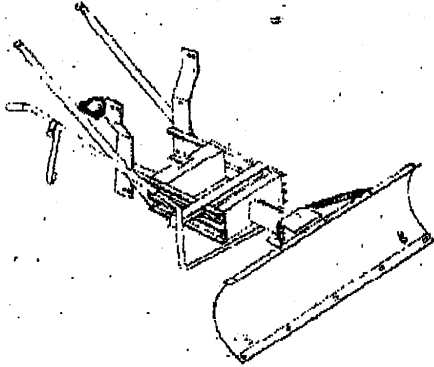

42" SNOW & GRADER BLADE

Rugged, heavy gauge steel blade. Spring loaded blade glides over uneven surfaces. Can be adjusted from seat for straight position, or 35 degrees left or right. Locks in raised position for traveling. Wheel and tire chains are recommended.

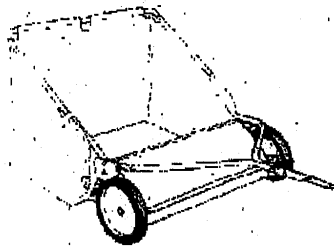

LAWN SWEEPER

Features extra heavy duty wheels and heavy duty basket. Basket is water, shrink and mildew proof with 6 bushel capacity. Dump release and height adjuster can both be operated from the tractor seat.

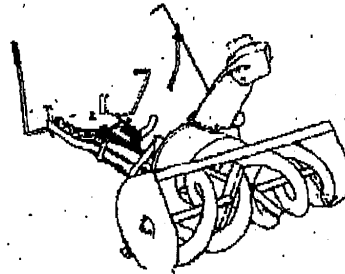

TWO STAGE SNOW THROWER

A powerful two stage snow thrower with a 1/4 inch second stage impeller capable of moving more than 70 tons of snow per hour and throwing it accurately in any direction you choose. Driver controlled discharge chute turns a 160 degree arc. Wheel weights and tire chains are recommended.

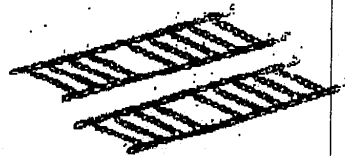

TIRE CHAINS

Tire chains for added traction are available. Specify tire size when ordering.

REAR WHEEL WEIGHTS

One pair, 50 pounds each. Total weight 100 pounds. Includes mounting hardware.