

**OWNER'S MANUAL**  
**REAR MOUNTED, SIDE DISCHARGE**  
**GRASS CATCHER KIT**  
**MODEL 5708-13**

**ONE YEAR LIMITED WARRANTY**

For one (1) year from date of purchase by the first customer for residential use (thirty (30) days commercial use), NOMA Outdoor Products Incorporated warrants that it will replace free of charge, including labor, any original part of any NOMA Outdoor Products Incorporated product found to be defective by any authorized Service Dealer of the factory.

This warranty does not cover battery (if so equipped) or engine (these items are covered by their manufacturer's own warranty). This warranty does not cover parts that have failed due to normal wear or parts that have failed subject to misuse or abuse. Transportation of the unit or part to and from an authorized Service Dealer or the factory is the responsibility of the owner.

A step by step explanation as to what procedure should be followed for this Warranty is:

1. If a part becomes defective, contact the store where the unit was purchased for the name and address of the authorized Service Dealer nearest to you.
2. If you cannot locate an authorized Service Dealer, write Service Department of NOMA Outdoor Products Incorporated for the name and address of the authorized Service Dealer in your area or call the Service Department at 1-901-422-1690.
3. Return the defective product, along with proof of purchase to such authorized Service Dealer for replacement of any defective part where covered by this warranty.

There is no other express warranty. Implied warranties, including those of merchantability and fitness for a particular purpose are limited to one (1) year from the date of purchase. Liability for incidental or consequential damages are excluded.

Some states do not allow limitations on how long an implied warranty lasts, so the above limitation may not apply to you. Some states do not allow the exclusion of incidental or consequential damages, so the above exclusion may not apply to you. This warranty gives you specific legal rights, and you may have other rights which vary from state to state.

**NOMA Outdoor Products Incorporated**

**Caller 8000**

**Jackson, TN 38308-8000**

**UNIT PARTS AND SERVICE**

This manual contains instructions for safety, assembly and maintenance. Read this manual carefully and completely so that you will know proper assembly, use and care of your unit. Also fill in and mail the registration card packed with the unit. For service other than covered in this manual, contact an authorized service dealer. A nationwide parts and service organization has been established to provide locally available parts and service. A list of authorized parts distributors has been included in this manual. When ordering repair parts, always give the following information: 1. The Part Name; 2. The Part Number; 3. The Quantity desired; 4. The Full (eight digit) Model Number of the unit. The model number will be found on a plate attached to the unit.



**Look for this symbol.**

**It means - ATTENTION! BECOME ALERT! A HAZARD TO OPERATOR, BYSTANDER, PROPERTY OR EQUIPMENT MAY EXIST.**

**NOMA Outdoor Products Incorporated**  
**Caller 8000**  
**Jackson, Tennessee 38308-8000**

Part No. 305643

0389



## OPERATIONAL PRECAUTIONS

THESE INSTRUCTIONS ARE FOR YOUR PROTECTION. PLEASE READ THEM CAREFULLY.



1. Know the controls and how to stop quickly. Read this Owner's Manual and review Riding Mower Manual. Wear safety glasses or eye shields while assembling or operating the riding mower with grass catcher attachment.
2. When using the riding mower with grass catcher attachment:
  - A. DO NOT operate the riding mower without the entire grass catcher assembly or discharge chute deflector in place.
  - B. Never make any adjustments or repairs while the engine is running.
  - C. Shut off engine when removing grass from grass catcher or unplugging mower chute or catcher tube.
  - D. DO NOT operate riding mower with grass catcher assembly while barefooted. ALWAYS wear substantial footwear, preferably steel-toed shoes. DO NOT wear loose fitting clothing that could get caught in any moving parts.
  - E. ALWAYS keep clear of discharge chute/tube or any moving parts while engine is running.
  - F. Mow only in daylight or good artificial light.
3. ALWAYS place the mower clutch lever in disengage position when not cutting grass, such as when crossing a rock or gravel driveway or roadway and when transporting the riding mower with grass catcher attachment.
4. Disengage mower blades, stop engine, remove ignition key and set parking brake before leaving operator's position.
5. Disengage power to mower blades, stop engine, remove ignition key, set parking brake and disconnect spark plug wire before making any repairs, adjustments or cleaning the riding mower or grass catcher attachment.
6. Check grass bags frequently for wear and/or deterioration. Replace worn or damaged bags.
7. DO NOT run engine indoors. Exhaust fumes contain CARBON MONOXIDE which is an ODERLESS and DEADLY GAS.
8. Take all possible precautions when leaving the riding mower unattended, such as disengaging the mower clutch lever, shifting into neutral, setting parking brake, stopping engine and removing ignition key.
9. NEVER store grass catcher with grass clippings in the catcher bags. Even a small pile of grass clipping can create enough heat to start a fire.
10. If grass catcher attachment will be used on other than level ground, the use of a front weight box is recommended.

## OWNER'S INFORMATION

Record the following information about your unit so that you will be able to provide it in case of loss or theft.

MODEL NUMBER:     -     (Enter complete 8 digit number from model plate on unit)

PURCHASE DATE: \_\_\_ / \_\_\_ / \_\_\_ CODE NO.: \_\_\_\_\_ SERIAL NO.: \_\_\_\_\_

DEALER'S NAME AND ADDRESS: \_\_\_\_\_

CITY: \_\_\_\_\_ STATE: \_\_\_\_\_ TELEPHONE: \_\_\_\_\_

## CONTENTS OF SHIPPING CARTON

- 1 - Grass Catcher Assembly
- 1 - Owner's Manual
- 1 - Latch Lever
- 1 - Mounting Bracket, R.H.
- 1 - Mounting Bracket, L.H.
- 1 - Grass Catcher Support
- 1 - Grass Catcher Cover Assembly
- 1 - Transition Chute
- 1 - Upper Tube
- 2 - Grass Bag Assemblies
- 1 - Bag of Assembly Parts Containing:
  - 1 - Latch Rod
  - 2 - Rubber Grommets
  - 3 - Cover Hinges
  - 2 - Retainer Straps
  - 1 - Tab (Latch Lever)
  - 6 - 1/4 x 5/8 inch Slot Head Screws
  - 2 - 1/4 x 3/4 inch Hex Head Screws
  - 6 - 1/4 inch Keps, Nuts (star washer attached)
  - 2 - 1/4 inch Locknuts
  - 4 - 5/16 x 1 inch Hex Head Screws
  - 1 - 5/16 x 1/2 inch Hex Washer Head Self-Tap Screw
  - 4 - 5/16 inch Locknuts

- 2 - 5/16 inch Keps, Nuts (star washer attached)
- 2 - 9/32 inch Flatwashers
- 2 - 5/16 inch Flatwashers

The parts bag may contain more fasteners than are required for your kit

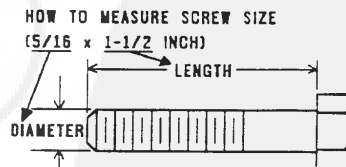

## TOOLS REQUIRED FOR ASSEMBLY

- 2 - 7/16 inch Wrenches (or adjustable wrenches)
- 2 - 1/2 inch Wrenches (or adjustable wrenches)
- 1 - Screwdriver
- 1 - Hammer (plastic or rawhide preferred)

## ASSEMBLY

### ⚠ DANGER ⚠

This riding mower and grass catcher attachment can be dangerous if carelessly used.

Read Operator's Manual thoroughly before operating machine.

Always wear safety glasses or eye shields when assembling or operating machine.

DO NOT carry passengers at any time.

Keep hands, feet, hair and loose clothing away from moving parts while engine is running.

DO NOT allow children or young teenagers to operate or be near machine while it is operating.

Your riding mower and grass catcher attachment have a right and left side as you face forward while seated in operator's seat.

If you have operated your riding mower prior to installing grass catcher kit, remove any accumulation of grass clipping from mower deck before installing kit.

### MOWER DECK ASSEMBLY

1. Place latch lever (figure 1) through hole in front of chute deflector bracket (with stud on lever down) and secure at back end with a 5/16 x 1/2 inch self-tap screw. **NOTE:** Some riding mowers may have this lever already installed.
2. Place the plastic tab (figure 1) onto front end of latch lever.

**Figure 1**

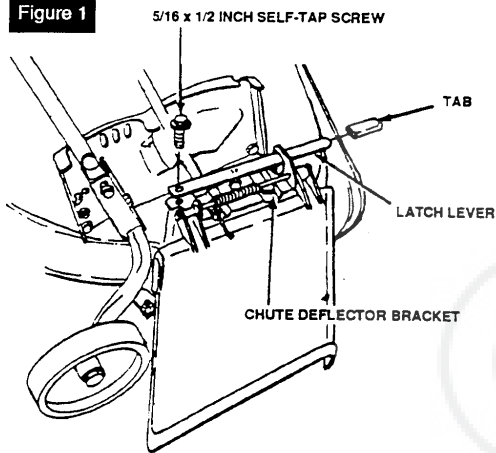

### TO INSTALL MOUNTING BRACKETS

Assembly will be easier if rear of riding mower is blocked up with rear wheels removed.

1. Place a mounting bracket (figure 2) on each side of main frame (rear). **NOTE:** If axle is attached directly to main frame, arms on mounting brackets must bend slightly toward center of main frame rear. If axle is attached to plates that are then attached to main frame, arms on brackets must bend slightly outward from center of main frame rear.

2. Attach each mounting bracket to side of main frame with two 5/16 x 1 inch hex head screws and two 5/16 inch locknuts (figure 2).

3. Reinstall rear wheels if removed.

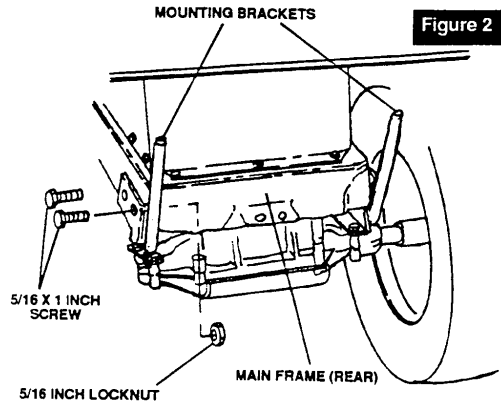

### GRASS CATCHER COVER ASSEMBLY

1. Thread a 5/16 inch keps nut all the way onto latch rod (figure 3).
2. Place threaded end of latch rod through hole in center arm of grass catcher support (figure 3) and secure with a 5/16 inch keps nut.
3. Lay grass catcher cover assembly upside down.
4. Place grass catcher support into ledge inside grass catcher cover assembly.
5. Attach three cover hinge straps and two retainer straps (on outside hinges) to cover and support assembly with six 1/4 x 5/8 inch screws and six 1/4 inch keps nuts.

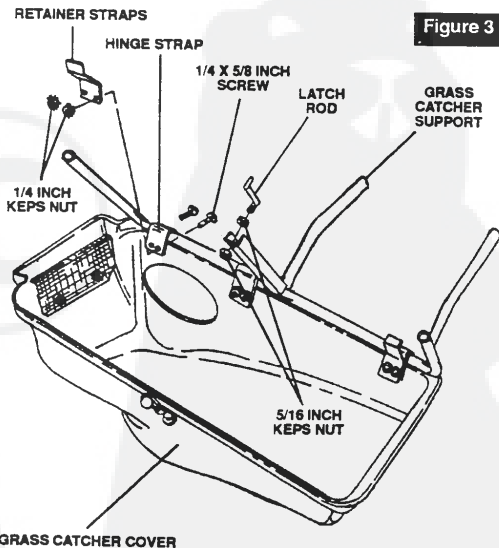

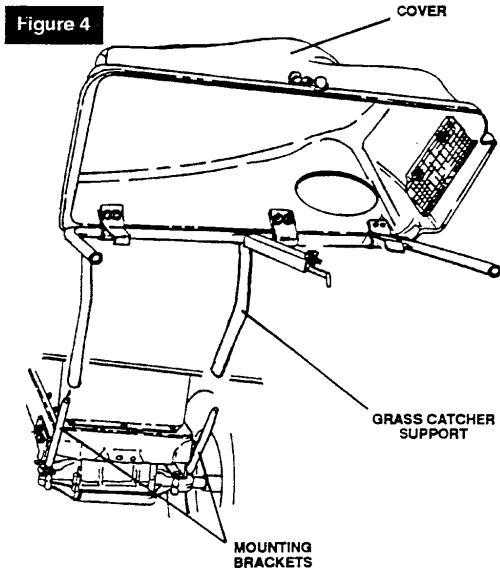

6. Turn cover assembly over and mount onto mounting brackets as shown in figure 4.

7. Pivot cover assembly toward front of grass catcher attachment and install grass bag assemblies as shown in figure 5. **NOTE:** Grass bags must be installed with solid panel in toward front of grass catcher.

8. Pivot cover assembly toward rear of grass catcher attachment and hook latch strap to latch pin (figure 5).

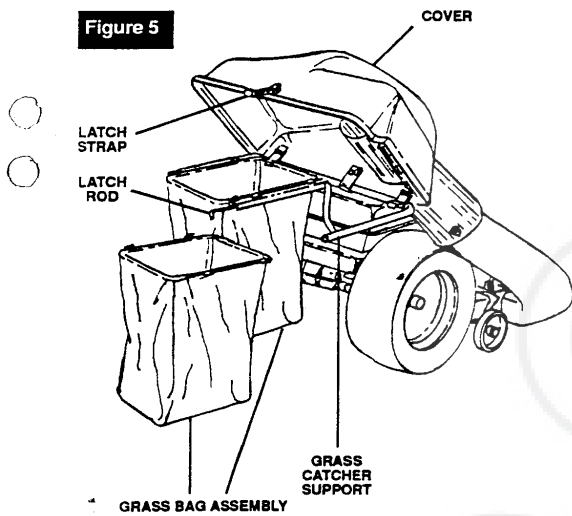

### DISCHARGE CHUTE ASSEMBLY

1. Place a rubber grommet into each large hole in upper tube (figure 6).

2. Attach upper tube to transition chute, as shown in figure 6, with two 1/4 x 3/4 inch hex head screws (from inside of transition chute), two large 9/32 inch flatwashers and two 1/4 inch locknuts.

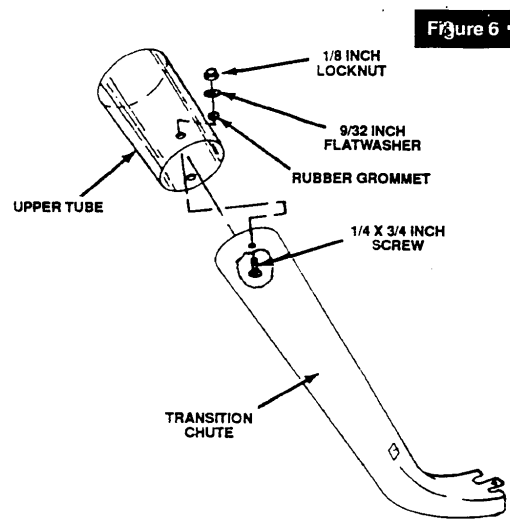

3. Place upper end of transition chute assembly into hole in front of grass catcher cover assembly.

4. Slide tab on lower end of transition chute under center of chute deflector bracket (figure 7) until stud on latch lever snaps into hole in end of tab. **NOTE:** Back side of transition chute should be on inside of deck opening and front side of transition chute should be on outside of deck opening.

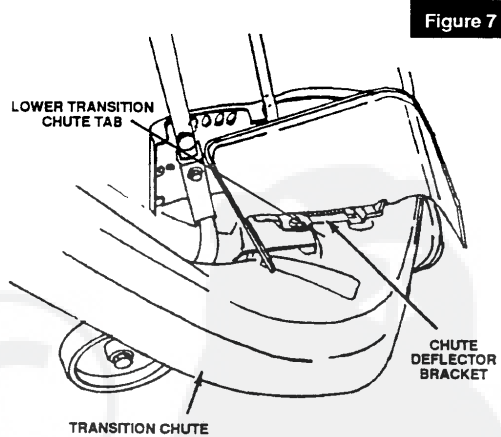

## OPERATION



### DANGER



**OPERATE MOWER WITH COMPLETE BAGGING ATTACHMENT IN PLACE.**

**SHUT OFF ENGINE BEFORE OPENING COVER OR EMPTYING GRASS BAGS.**

**OBJECTS MAY BE THROWN FROM DISCHARGE TUBE.**

**DO NOT REACH INTO DISCHARGE TUBE WHILE ENGINE IS RUNNING;**

The operation of this riding mower and grass catcher can result in objects being thrown into the eyes, which can result in severe eye damage. Always wear safety glasses or eye shields while operating a riding mower. We recommend standard safety glasses, or Wide Vision safety mask for over spectacles.

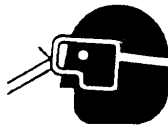

Get to know your riding mower and its controls. Be sure you (or any other operator) have read and understood the **Operational Precautions** Listed on page 2 of this manual and in your riding mower operator's manual.

Avoid sharp turns at high speed and uphill or downhill turns. Operate mower carefully. Be especially cautious on hills. When riding down inclines, keep shift control in low speed. Use brake for fast stops on hill. When operating on hills the use of a front weight box attachment is recommended. Use weight box kit #5709.

### CAUTION

**If grass catcher attachment will be used on other than level ground, the use of a front weight box is recommended.**

If grass clippings are going to be bagged and hauled away, you may line grass bag assemblies with a 30 x 36 plastic trash bag. Roll top of bag around frame of grass bag to hold in place during collection.

#### OPERATION (Rider with Catcher)

Take a comfortable position on the riding mower and start the riding mower engine. After engine warmup, depress brake-clutch pedal and move shift control lever to desired forward gear. Release brake-clutch pedal slowly and riding mower will move forward. Until you get the feel of the machine, stay in the low speed position. With mower blades stopped, make your first run in a large, open, level area. Learn to start, stop and change direction in this area.

Stop engine before leaving operator's position.

The engine should be run at fast throttle for proper grass cutting and collecting of clippings, and ground speed controlled by shift lever position. Forward speed of the riding quantity of grass being mowed. The more grass that must be cut, the slower the speed forward should be. When cutting light grass, the forward speed can be increased. By observing the collecting action of your mower, you can determine how fast you can travel.

To mow heavy growth or on rough ground, set mower at maximum height. After growth is cleared, reduce cutting height as desired.

Height-of-cut should not be set too low on thick, lush lawns, or grass may die. If height is too low, the deck wheels may sink into the lawn, causing the mower deck to drop down on the grass and reduce the discharging effect of the cutting blade. New grass should be cut in the afternoon when it is dry. Never cut wet grass. Wet grass will pack under mower deck and in transition chute and will not discharge properly.

**KEEP EQUIPMENT CLEAN.** Grass clippings may pack under the mower chassis and in discharge chute assembly due to the internal moisture content of the grass. This accumulation of cut grass should be removed after each mowing.

1. Disconnect spark plug wire, remove ignition key, set parking brake on riding mower.

2. Scrape accumulation off underside of mower deck with a putty knife or similar tool. Cleaning of the underside of mower housing is easier if mower deck is removed. See **Mower Deck Removal** paragraph in **Maintenance** section of riding mower operator's manual.

3. Remove discharge chute assembly from mower deck and grass catcher cover assembly and flush grass clippings with water.

4. Remove grass catching bags and flush grass clippings from cover assembly with water.

#### TO EMPTY GRASS CATCHER BAG

Check grass catcher bags at frequent intervals while mowing. Bag should be emptied as soon as clippings reach top of bag and after each use. To empty bag, proceed as follows:

1. Move mower clutch lever to **DISENGAGE** position and shift lever to **NEUTRAL** position.

2. Stop engine and set parking brake on riding mower.

3. Unlock latch strap from latch rod. (figure 8).

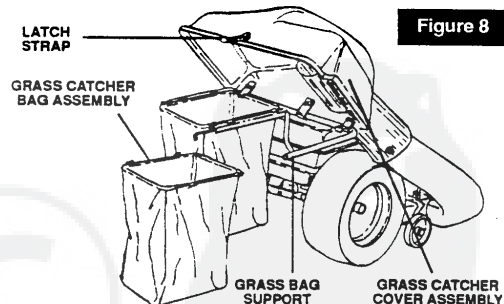

4. Pivot cover assembly toward front of grass catcher and lift bag assemblies from support.

5. Remove all clippings from bags.



### DANGER



**NEVER store grass catcher with grass clipping in the catcher bags. Even a small pile of grass clippings can create enough heat to start a fire.**

6. Reinstall bag assemblies.

7. Pivot cover assembly toward rear of grass catcher and hook latch strap to latch rod.

**⚠ DANGER ⚠**  
**DO NOT OPERATE MOWER UNLESS ENTIRE GRASS CATCHER ATTACHMENT IS IN PLACE.**

### TO CLEAR PLUGGED DISCHARGE CHUTE

Your discharge chute may become plugged with grass clipping due to over-filling grass catcher or cutting grass that is too long or wet. To unplug chute, proceed as follows:

1. Move mower clutch lever to DISENGAGE position and shift lever to neutral.
2. Stop engine and set parking brake.

**⚠ DANGER ⚠**  
**Blades will not stop immediately. Keep hands and feet from under mower and away from the discharge chute.**

3. Disconnect spark plug wire.
4. Lift front end of latch lever and pull transition chute away from mower deck.

5. Remove chute assembly from grass catcher cover assembly
6. Shake grass clipping from chute assembly.
7. Remove clippings from mower deck discharge chute.
8. Re-attach chute assembly to grass catcher and mower deck in reverse order of removal.
9. Reconnect spark plug wire.

## STORAGE

The grass catcher attachment should be immediately prepared for storage at the end of the season. To prepare grass catcher attachment for storage, proceed as follows:

1. Remove and clean chute assembly.
2. Remove and empty grass bag assemblies.

**⚠ DANGER ⚠**  
**NEVER store grass catcher attachment with grass clippings in the bags. Even a small pile of grass clippings can create enough heat to start a fire.**

3. Clean the grass catcher cover assembly thoroughly.
4. Inspect the grass catcher and mower deck assemblies for worn or damaged parts. Tighten all loose hardware.
5. Check grass bags for wear and/or deterioration. Replace worn or damaged bags.
6. Store the riding mower and grass catcher attachment in a clean, dry area and cover for additional protection. **NOTE:** The grass catcher assembly can be easily lifted off the riding mower to reduce storage space.

## REPAIR PARTS

- ALWAYS GIVE THE FOLLOWING INFORMATION WHEN ORDERING REPAIR PARTS:**
1. The PART NUMBER; 2. The PART NAME; 3. QUANTITY DESIRED; 4. The MODEL NUMBER (As shown on Model Plate).
- SEND PART ORDERS AS PER INSTRUCTIONS ON THE FRONT PAGE.**  
**YOUR UNIT IS RIGHT HAND (RH) OR LEFT HAND (LH) AS YOUR STAND BEHIND IT.**  
**DO NOT USE KEY NUMBERS WHEN ORDERING REPAIR PARTS, ALWAYS USE PART NUMBERS.**  
All replacement parts will be supplied in current production colors or in a neutral color.  
A handling fee is applicable to small parts orders.

## REAR MOUNTED, SIDE DISCHARGE GRASS CATCHER KIT MODEL 5708-13

Key No.	Part No.	Description	Key No.	Part No.	Description
1	57034	Screw, SI Fl Hd, No. 10-24 x 5/8 In.	17	57626	Flatwasher, 9/32 In.
2	48704	Latch, Strap, Rubber	18	57506	Rubber Grommet
3	46563	Shoulder Bolt, Cover Latch	19	57667	Upper Tube Assembly
4	58301	Cover	20	58283	Bag
5	120385	*Flatwasher, 1/4 In.	21	120386	*Flatwasher, 5/16 In.
6	9424215	Locknut, 1/4-20 Thd.	22	180020	*Screw, Hex Hd, 1/4-20 x 3/4 In.
7	55686	Screw, SI Rd Hd, 1/4-20 x 5/8 In.	23	57786	Chute, Transition
8	271172	*Nut, Keps, 1/4-20 Thd.	24	35497	Screw, Taptite, 5/16-18 x 1/2 In.
9	300278	Hinge, Cover	25	58320	Lever, Latch
10	300624	Retaining Straph	26	70325	Decal, Transition Chute
11	58282	Support Assembly	27	42348	Tab
12	300517	Latch, Rod Cover	28	180079	*Screw, Hex Hd, 5/16-18 x 1 In.
13	271184	*Nut, Keps, 5/16-18 Thd.	29	300120	Bracket Assy, Support Mount, R.H.
14	271166	Nut, Keps, No. 10-24	30	9413447	Locknut, 5/16-19 Thd.
15	9417373	Flatwasher, 13/64 In.	31	300121	Bracket Assy, Support Mount, L.H.
16	300115	Screen	32	305643	Owner's Manual (Not Illustrated)

(\*) Standard Hardware Items - May be Purchased Locally.

