

# OWNER'S MANUAL

## 40" REAR MOUNTED, SIDE DISCHARGE, GRASS CATCHER FOR 4-WHEEL STEER TRACTOR MODEL 5708-2300

### ONE YEAR LIMITED WARRANTY

For one (1) year from date of purchase by the first consumer for residential use (thirty (30) days commercial use), NOMA Outdoor Products Incorporated warrants that it will replace free of charge, including labor, any original part of any NOMA Outdoor Products Incorporated product found to be defective by any authorized Service Dealer or the factory, except the battery which is warranted for ninety (90) days from date of purchase.

This warranty does not cover engine, transmission, transaxle or differential (these items are covered by their manufacturer's own warranty). This warranty does not cover parts that have failed due to normal wear or parts that have failed subject to misuse or abuse. Transportation of the unit or part to and from an authorized Service Dealer or factory is the responsibility of the owner.

A step by step explanation as to what procedure should be followed for this Warranty is:

1. If a part becomes defective, contact the store where the unit was purchased for the name and address of the authorized Service Dealer nearest to you.
2. If you cannot locate an authorized Service Dealer, write Service Department of NOMA Outdoor Products Incorporated for the name and address of the authorized Service Dealer in your area or call the Service Department at 1-901-422-1690.
3. Return the defective product, along with proof of purchase to such authorized Service Dealer for replacement of any defective part where covered by this warranty.

There is no other express warranty. Implied warranties, including those of merchantability and fitness for a particular purpose are limited to one (1) year from date of purchase. Liability for incidental or consequential damages are excluded.

Some states do not allow limitations on how long an implied warranty lasts, so the above limitation may not apply to you. Some states do not allow the exclusion of incidental or consequential damages, so the above exclusion may not apply to you. This warranty gives you specific legal rights, and you may have other rights which vary from state to state.

NOMA Outdoor Products Incorporated

Caller 8000

Jackson, TN 38308-8000

### UNIT PARTS AND SERVICE

This manual contains instructions for safety, assembly and maintenance. Read this manual carefully and completely so that you will know proper assembly, use and care of your unit. Also fill in and mail the registration card packed with the unit. For service other than covered in this manual, contact an authorized service dealer. A nationwide parts and service organization has been established to provide locally available parts and service. A list of authorized parts distributors has been included in this manual. When ordering repair parts, always give the following information: 1. The Part Name; 2. The Part Number; 3. The Quantity desired; 4. The Full (eight digit) Model Number of the unit. The model number will be found on a plate attached to the unit.



**Look for this symbol. It means - ATTENTION! BECOME ALERT! A HAZARD TO OPERATOR, BYSTANDER, PROPERTY OR EQUIPMENT MAY EXIST.**

NOMA Outdoor Products Incorporated

Caller 8000

Jackson, TN 38308-8000

Part No. 310217B

0490

Price \$2.00

Printed in U.S.A.



## SAFETY RULES



THESE INSTRUCTIONS ARE FOR YOUR PROTECTION. PLEASE READ THEM CAREFULLY.

1. Know the controls and how to stop quickly. **READ THIS OWNER'S MANUAL** and review the tractor **Owner's Manual**. Wear safety glasses or eye shields while assembling or operating the tractor with the grass catcher.
2. When using the tractor with the grass catcher:
  - A. **DO NOT** operate the tractor without the entire grass catcher assembly or the chute deflector in place.
  - B. Never make any adjustments or repairs while the engine is running.
  - C. Shut off the engine when removing grass from the grass catcher or unplugging the mower chute or the grass catcher chute.
  - D. **DO NOT** operate the tractor with grass catcher assembly while barefooted. **ALWAYS** wear substantial footwear, preferably steel-toed shoes. **DO NOT** wear loose fitting clothing that could get caught in any moving parts.
  - E. **ALWAYS** keep clear of the grass catcher chute or any moving parts while the engine is running.
  - F. Mow only in daylight or good artificial light.
3. **ALWAYS** place the mower clutch lever in the **OFF** position when not cutting grass, such as when crossing a rock or gravel driveway or roadway and when transporting the tractor with grass catcher.
4. Place the mower clutch lever in the **OFF** position to disengage the power to the mower blades, stop the engine, remove the ignition key and set the parking brake before leaving the operator's position.
5. Place the mower clutch lever in the **OFF** position to disengage power to the mower blades, stop the engine, remove the ignition key, set the parking brake and disconnect the spark plug wire(s) before making any repairs, adjustments or cleaning the tractor or grass catcher.
6. Check the grass bags frequently for wear and/or deterioration. Replace worn or damaged bags.
7. **DO NOT** run the engine indoors. Exhaust fumes contain **CARBON MONOXIDE** which is an **ODORLESS** and **DEADLY GAS**.
8. Take all possible precautions when leaving the tractor unattended, such as placing the mower clutch lever in the **OFF** position to disengage the mower blades, shifting the shift control lever into the neutral position, setting the parking brake, stopping the engine and removing the ignition key.
9. **NEVER** store the grass catcher with grass clippings in the grass catcher bags. Even a small pile of grass clippings can create enough heat to start a fire.
10. If the grass catcher will be used on other than level ground, the use of a front weight box is recommended.

## OWNER'S INFORMATION

Record the following information about your unit so that you will be able to provide it in case of loss or theft.

MODEL NUMBER:  -  (Enter complete 8 digit number from model plate on unit)

PURCHASE DATE: \_\_\_ / \_\_\_ / \_\_\_ CODE NO.: \_\_\_\_\_ SERIAL NO.: \_\_\_\_\_

DEALER'S NAME AND ADDRESS: \_\_\_\_\_

CITY: \_\_\_\_\_ STATE: \_\_\_\_\_ TELEPHONE: \_\_\_\_\_

### CONTENTS OF SHIPPING CARTON

- 1 - Grass Catcher Assembly
- 1 - Owner's Manual
- 1 - Mounting Bracket, R.H.
- 1 - Mounting Bracket, L.H.
- 1 - Lower Chute
- 1 - Upper Chute
- 2 - Grass Catcher Bag
- 1 - Bag of Assembly Parts Containing:
  - 1 - Latch Lever (40 inch mower deck)
  - 1 - Tab (Latch Lever)
  - 1 - 5/16 x 2 inch Eye Bolt
  - 6 - 5/16 inch Locknuts
  - 1 - 5/16 inch Keps Nut
  - 3 - 11/32 inch Flatwashers
  - 2 - 1-3/4 inch Clevis Pin
  - 2 - 1-5/8 inch Hair Pin
  - 1 - 5/16 x 1 inch Hex Head Screw

### TOOLS REQUIRED FOR ASSEMBLY

- 2 - 1/2 inch Wrenches (or adjustable wrenches)
- 1 - Hammer (plastic or rawhide preferred)

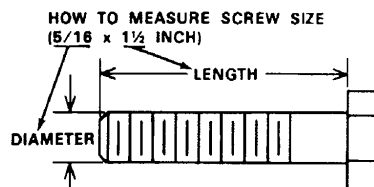

The parts bag may contain more fasteners than are required for your kit.

## ASSEMBLE YOUR GRASS CATCHER



### DANGER



This tractor and grass catcher can be dangerous if carelessly used.

Read the Owner's Manual thoroughly before operating the tractor.

Always wear safety glasses or eye shields when assembling or operating the tractor.

DO NOT carry passengers at any time.

Keep hands, feet, hair and loose clothing away from moving parts while the engine is running.

DO NOT allow children or young teenagers to operate or be near the tractor while it is operating.

Your tractor and grass catcher have a right and left side as you face forward while seated in the operator's seat.

If you have operated your tractor prior to installing the grass catcher, remove any accumulation of grass clippings from the mower deck before installing the grass catcher.

### MOWER DECK ASSEMBLY

The mower deck assembly includes the installation of the lever latch for the lower chute.

To install the lever latch, do the following:

1. Place the latch lever (Figure 1) through the hole in the front of the chute deflector bracket (with the stud on the lever pointing down).

Figure 1

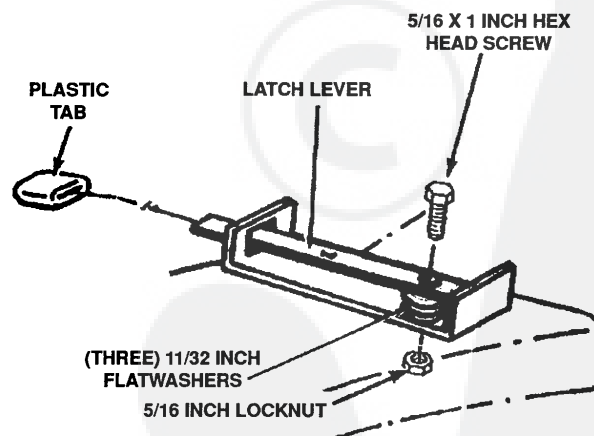

2. Attach the latch lever to the mower deck with a 5/16 x 1 inch hex head screw, a 5/16 inch locknut and three 11/32 inch flatwashers (Figure 1).

### NOTE

Some tractors may have this lever already installed.

3. Place the plastic tab (Figure 1) on the end of the latch lever.

To install the hi-lift blades, do the following:

1. Remove the mower deck and remove the blades (see the owner's manual for your unit).
2. Install the hi-lift blades. Torque mounting hardware to 30-35 ft. lbs.
3. Reinstall the mower deck.

### INSTALL THE MOUNTING BRACKETS

1. Remove four 5/16 inch hex head tapite screws from the rear of your tractor.
2. Raise the tractor seat. **NOTE: Prior to installing left and right hand mounting brackets to rear of tractor, apply a liberal amount of grease to the inside of the bracket tubes. (Figure 2).**
3. Align the bottom hole and the third from the bottom hole in the right-hand mounting bracket with the holes in the rear of the tractor (Figure 2 Inset).
5. Insert two of the screws (removed in step 1) in the holes do not tighten at this time (Figure 2).
6. Place a 5/16 inch locknut on the end (inside the battery compartment) of each screw (Figure 2).
7. Repeat steps 3 through 6 for the left-hand mounting bracket.
8. Insert grass catcher support into mounting brackets and tighten mounting bracket hardware (Figure 3).

## ASSEMBLE YOUR GRASS CATCHER

**Figure 2**

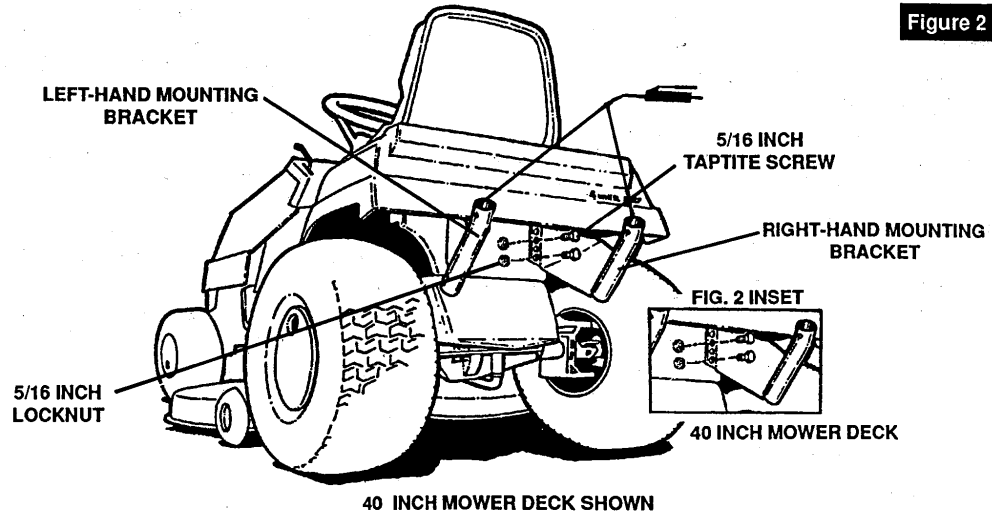

**40 INCH MOWER DECK SHOWN**

### INSTALL THE GRASS CATCHER SUPPORT

1. Align the holes in the legs of the grass catcher support with the holes in the mounting brackets.

2. Insert a 1-3/4 inch clevis pin through the holes.
3. Insert a 1-5/8 inch cotter pin in the hole of the clevis pins.

**Figure 3**

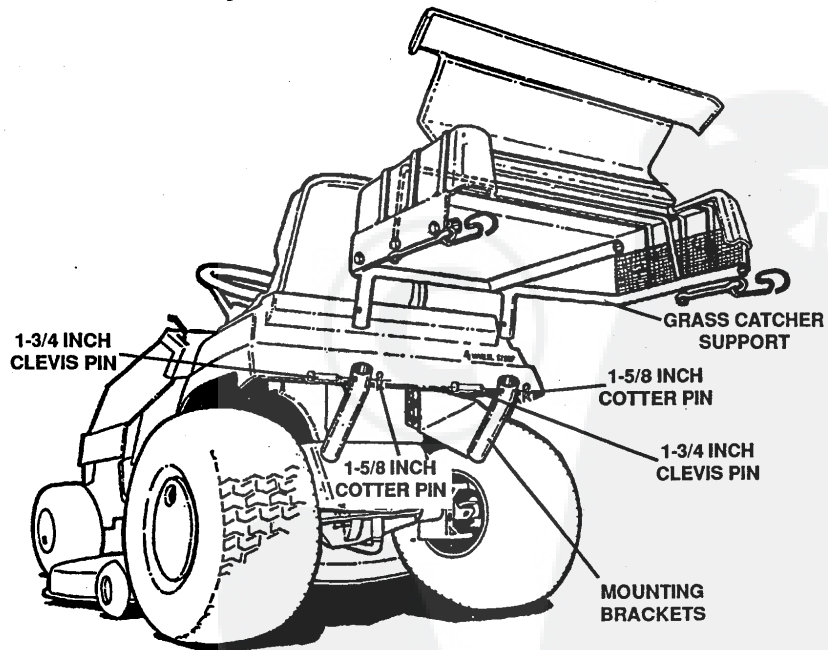

## ASSEMBLE YOUR GRASS CATCHER

### INSTALL THE CHUTE ASSEMBLY

1. Screw a 5/16 inch hex head keps nut onto the 5/16 x 2 inch eye bolt until approximately one-half inch of threads are shown.
2. Remove the second screw from the chute opening on the front of the mower. Insert the threaded end of the eye bolt into the hole as shown in Figure 4.

#### NOTE

You may have to completely remove the baffle to be able to remove the 5/16 x 5/8 inch screw.

4. Screw a 5/16 inch locknut onto the eye bolt. Tighten the 5/16 inch locknut down to secure the eye bolt in place.
5. Install the two rubber straps on the end of the lower chute with two 1/4 x 1 inch hex head screws, two 9/32 inch flatwashers and one 1/4 inch locknut (Figure 4).
6. Lift up on the chute deflector.

7. Slide the tab on the lower end of the lower chute under the center of the chute deflector until the stud on the latch lever snaps in the hole in the end of the tab.
8. Attach the "S" hook on the end of the front rubber strap to the eye bolt (Figure 4).
9. Attach the "S" hook on the end of the rear rubber strap to the bottom edge of the mower deck wheel bracket (Figure 4).
10. Place the end of the upper chute in the hole in the front of the grass catcher cover (Figure 5).
11. Place the latch end of the upper chute over the end of the lower chute. Slide the end all the way down to the stop on the lower chute (Figure 5).
12. Lift up on the chute latch and place over the stop on the lower chute (Figure 5).

**Figure 4**

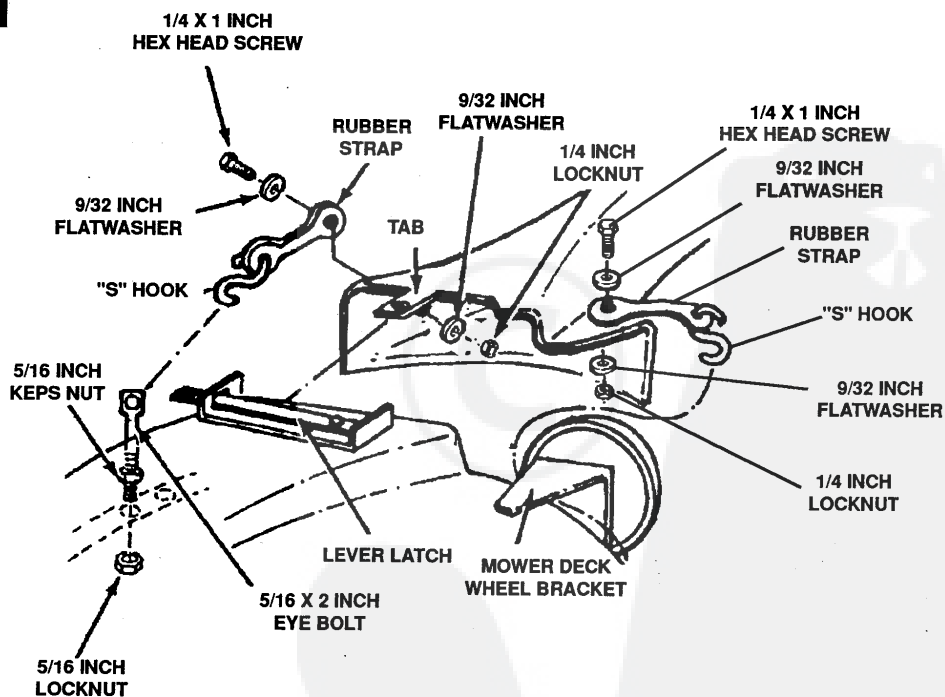

## ASSEMBLE YOUR GRASS CATCHER

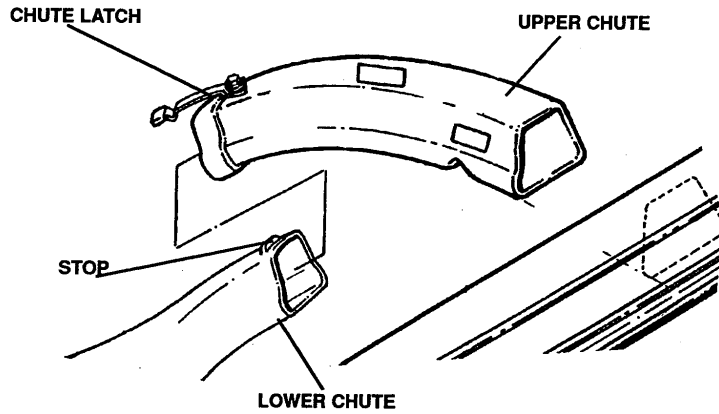

Figure 5

### INSTALL THE GRASS CATCHER BAGS

1. Unhook the rubber straps on each side of the grass catcher lid and lift the grass catcher lid.
2. Place the bags on the grass catcher support with solid material facing wheels (Figure 6).
3. Close the grass catcher lid and rehook the rubber straps.

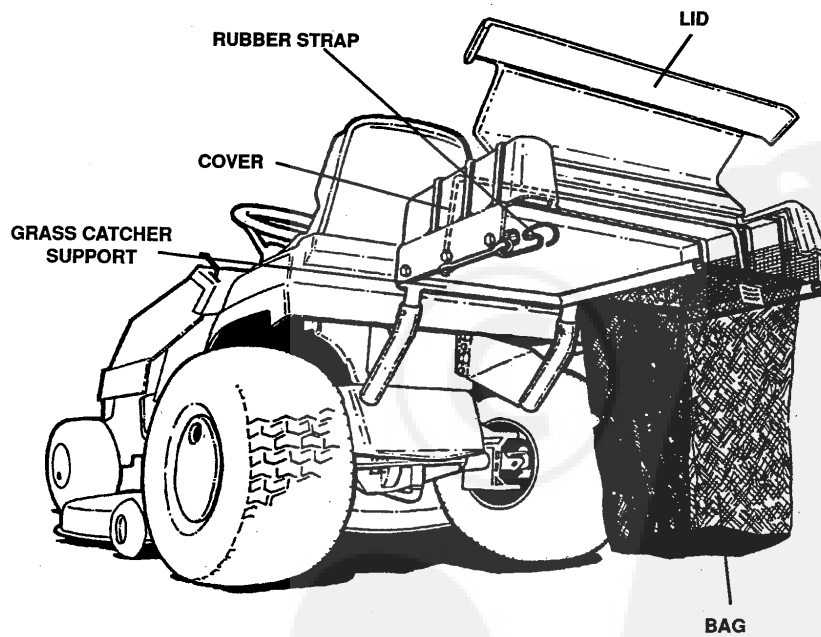

Figure 6



## OPERATE YOUR GRASS CATCHER



### DANGER



OPERATE THE MOWER WITH THE COMPLETE GRASS CATCHER IN PLACE.

SHUT OFF THE ENGINE BEFORE OPENING THE COVER OR EMPTYING THE GRASS BAGS.

OBJECTS MAY BE THROWN FROM DISCHARGE CHUTE.

DO NOT REACH INTO THE DISCHARGE CHUTE WHILE THE ENGINE IS RUNNING.

The operation of your tractor and grass catcher can result in objects being thrown into the eyes, which can result in severe eye damage. Always wear safety glasses or eye shields while operating your tractor. We recommend standard safety glasses, or Wide Vision safety mask for over spectacles.

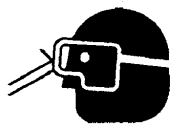

Get to know your tractor and its controls. Be sure you (or any other operator) have read and understand the **Safety Rules** on page 2 of this manual and in **Owner's/Operator's Manual** for your tractor.

Avoid sharp turns at high speed and uphill or downhill turns. Operate the tractor carefully. Be especially cautious on hills. When riding down inclines, keep the shift control lever in a low speed. Use the brake for fast stops on a hill.

If grass clippings are going to be bagged and hauled away, you may line the grass bag assemblies with a 30 x 36 plastic trash bag. Roll the top of the bag around the frame of the grass bag to hold it in place during collection.

### OPERATION (Tractor with Catcher)

Take a comfortable position on your tractor and start the engine. After engine has warmed up, depress the clutch-brake pedal and move the shift control lever to the forward gear you want. **Release the clutch-brake pedal slowly and the tractor will move forward. Until you get the feel of the tractor, stay in the low speed range.** With the mower blades stopped, make your first run in a large, open, level area. Learn to start, stop and change direction in this area.

Stop the engine before leaving the operator's position.

The engine should be run at the fast throttle position for proper grass cutting and collecting of clippings, and the ground speed is controlled by the position of the shift lever. The forward speed of the tractor is determined by the quantity of the grass being mowed. The more grass that must be cut, the forward speed will be slower. When cutting light grass, the forward speed can be increased. By observing the collecting

action of your mower, you can determine how fast you can travel.

To mow heavy growth or on rough ground, set the mower at maximum height. After the growth is cleared, reduce the cutting height as desired.

The cutting height should not be set too low on thick, lush lawns, or the grass may die. Also, if the cutting height is too low, the deck wheels may sink into the lawn, causing the mower deck to drop down on the grass and reduce the discharging effect of the cutting blade. New grass should be cut in the afternoon when it is dry. Never cut wet grass. Wet grass will pack under the mower deck and in grass chutes and will not discharge properly.

**KEEP THE EQUIPMENT CLEAN.** Grass clippings may pack under the mower chassis and in the grass chutes due to the internal moisture content of the grass. This accumulation of grass clippings should be removed after each mowing.

1. Disconnect the spark plug wire(s), remove the ignition key and set the parking brake on the tractor.

2. Scrape the grass clippings off the underside of the mower deck with a putty knife or similar tool. Cleaning the underside of the mower housing is easier if the mower deck is removed. See the **Remove The Mower Deck** paragraph in **Maintain Your Tractor** section of the **Owner's/Operator's Manual** for your tractor.

3. Remove the upper and lower chutes from the mower deck and the grass catcher cover assembly. Flush the grass clippings with water.

4. Remove the grass catcher bags. Flush the grass clippings from the cover assembly with water.

### EMPTY THE GRASS CATCHER BAGS

At frequent intervals, stop your tractor and check the grass catcher bags. The bags should be emptied as soon as clippings reach top of bag and after each use. The bags are full when the grass clippings begin to come out of the hole underneath the upper chute.

**To empty bag, do the following:**

1. Move the mower clutch lever to the **OFF** (disengaged) position and move the shift control lever to the neutral position.

2. Stop the engine and set the parking brake on your tractor.

3. Unhook the rubber straps and lift up on the cover lid (**Figure 7**).

4. Lift the bag assemblies from the support.

5. Remove all clippings from the bags.



## OPERATE YOUR GRASS CATCHER

Figure 7

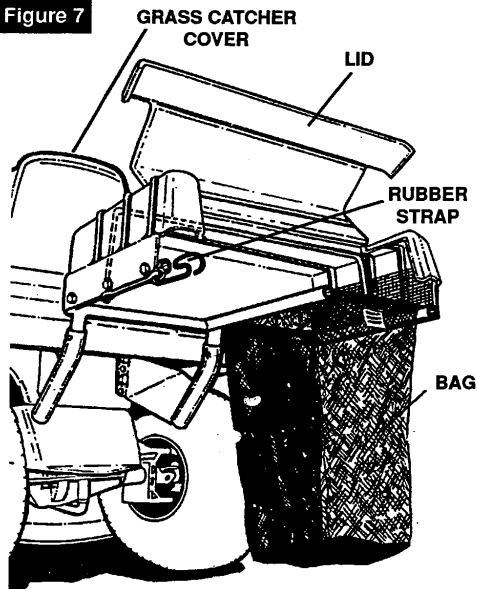

**⚠ DANGER ⚠**  
DO NOT OPERATE YOUR TRACTOR UNLESS THE ENTIRE GRASS CATCHER IS IN PLACE.

### CLEAR A PLUGGED GRASS CHUTE

Your grass catcher chute may become plugged with grass clippings due to over-filling the grass catcher

bags or cutting grass that is too long or wet. To the unplug the chute, do the following:

1. Move the mower clutch lever to the **OFF** position, move the shift control lever to the neutral position, turn the engine off and set the parking brake.

**⚠ DANGER ⚠**  
The blades on the mower deck will not stop immediately. Keep your hands and feet from under the mower and away from the grass catcher chute.

2. Disconnect the spark plug wire(s).
3. Lift up on the upper chute lever latch and pull the upper chute away from the lower chute.
4. Clear the grass clippings out of the upper chute.
5. Disconnect the two rubber straps holding the lower chute to the mower deck.
6. Lift the front end of the latch lever and pull the lower chute away from the mower deck.
7. Clear the grass clippings out of the lower chute.
8. Clear the grass clippings from the mower deck chute deflector assembly.
9. Re-attach the chute assembly to the grass catcher and the mower deck in reverse order of removal.
10. Reconnect the spark plug wire(s).

## STORAGE

The grass catcher should be immediately prepared for storage at the end of the season. To prepare the grass catcher for storage, do the following:

1. Remove and clean the upper and lower chutes.
2. Remove and empty the grass bags.

**⚠ DANGER ⚠**  
NEVER store the grass catcher attachment with grass clippings in the bags. Even a small pile of grass clippings can create enough heat to start a fire.

4. Inspect the grass catcher and the mower deck assemblies for worn or damaged parts. Tighten all the loose hardware.
5. Check the grass bags for wear and/or deterioration. Replace any worn or damaged bags.
6. Store your tractor and grass catcher in a clean, dry area and cover for additional protection.

### NOTE

The grass catcher can be easily lifted off the tractor to reduce the storage space.

3. Clean the grass catcher cover and lid thoroughly.

Part No. 310217B

## REPAIR PARTS

40" REAR MOUNTED, SIDE DISCHARGE, GRASS CATCHER MODEL 5708-2300

ALL UNNUMBERED  
ITEMS ARE INTERCHANGEABLE  
WITH OPPOSITE SIDE

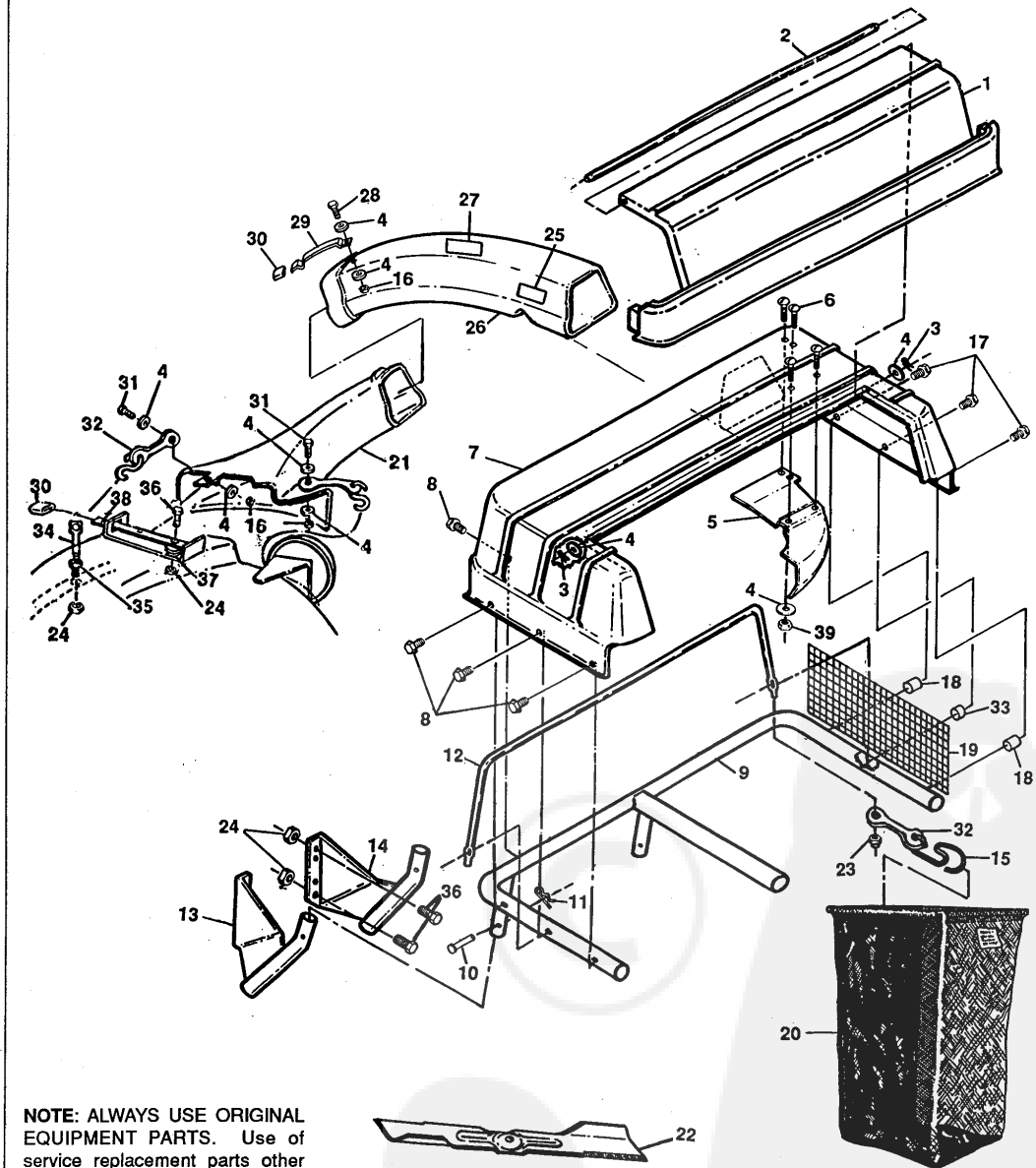

## 40" REAR MOUNTED, SIDE DISCHARGE, GRASS CATCHER, MODEL 5708-2300

ALWAYS GIVE THE FOLLOWING INFORMATION WHEN ORDERING REPAIR PARTS:

1. The PART NUMBER; 2. The PART NAME; 3. QUANTITY DESIRED; 4. The MODEL NUMBER (As shown on Model Plate).  
SEND PART ORDERS AS PER INSTRUCTIONS ON THE FRONT PAGE.

YOUR UNIT IS RIGHT HAND (RH) OR LEFT HAND (LH) AS YOU STAND BEHIND IT.

DO NOT USE KEY NUMBERS WHEN ORDERING REPAIR PARTS, ALWAYS USE PART NUMBERS.

All replacement parts will be supplied in current production colors or in a neutral color.

A handling fee is applicable to small parts orders.

Key No.	Part No.	Description	Key No.	Part No.	Description
1	309320	Lid, Grass Catcher	24	1498	*Locknut, 5/16-18 Thd.
2	310194	Pivot Rod	25	306498	Decal, Full Indicator
3	121223	Pin, Cotter .062 Dia. x 3/4 In.	26	305319	Chute, Upper
4	120392	Flatwasher, 9/32 In.	27	70325	Decal, Danger
5	305197	Baffle, Grass Catcher	28	121887	Screw, Hex Hd, 1/4-20 x 3/4 In.
6	55686	Screw, Slit, Ma Hd, 1/4 x 5/8 In.	29	306492	Latch, Lever
7	309295	Cover, Grass Catcher	30	42348	Tab, Plastic
8	44811	Screw, Taptite, 1/4-20 x 3/4 In.	31	121900	Screw, Hex Hd, 1/4-20 x 1 In.
9	309709	Grass Catcher Support	32	57505	Strap, Rubber
10	308619	Pin, Clevis, 1-3/4 inch	33	309296	Spacer
11	56180	Pin, Cotter, .091 Dia. x 1-5/8 In.	34	51183	Bolt, Eye, 5/16-18 x 2 In.
12	311652	Support Rod	35	271184	Nut, Keps, 5/16-18 Thd.
13	309712	Bracket Assy., R.H.	36	122017	Screw, Hex Hd, 5/16-18 x 1 In.
14	309711	Bracket Assy., L.H.	37	120393	Flatwasher, 11/32 In.
15	309648	Rubber Strap, Hold Down	38	9137	Lever Assembly
16	1502	*Locknut, 1/4-20 Thd.	39	271172	Nut, Keps, 1/4-20 Thd
17	306487	Screw, Taptite, 1/4-20 x 1-1/2 In.	40	310217	Owner's Manual (Not Illustrated)
18	306079	Spacer			
19	306262	Screen			
20	309365	Bag, Grass Catcher			
21	305903	Chute, Lower			
22	309070	Hi-lift blade			
23	73664	Push Nut			

(\*) Standard Hardware Items - May be Purchased Locally.