

T 10/92 RD / 106728

CHASSIS & HOOD ASSEMBLY

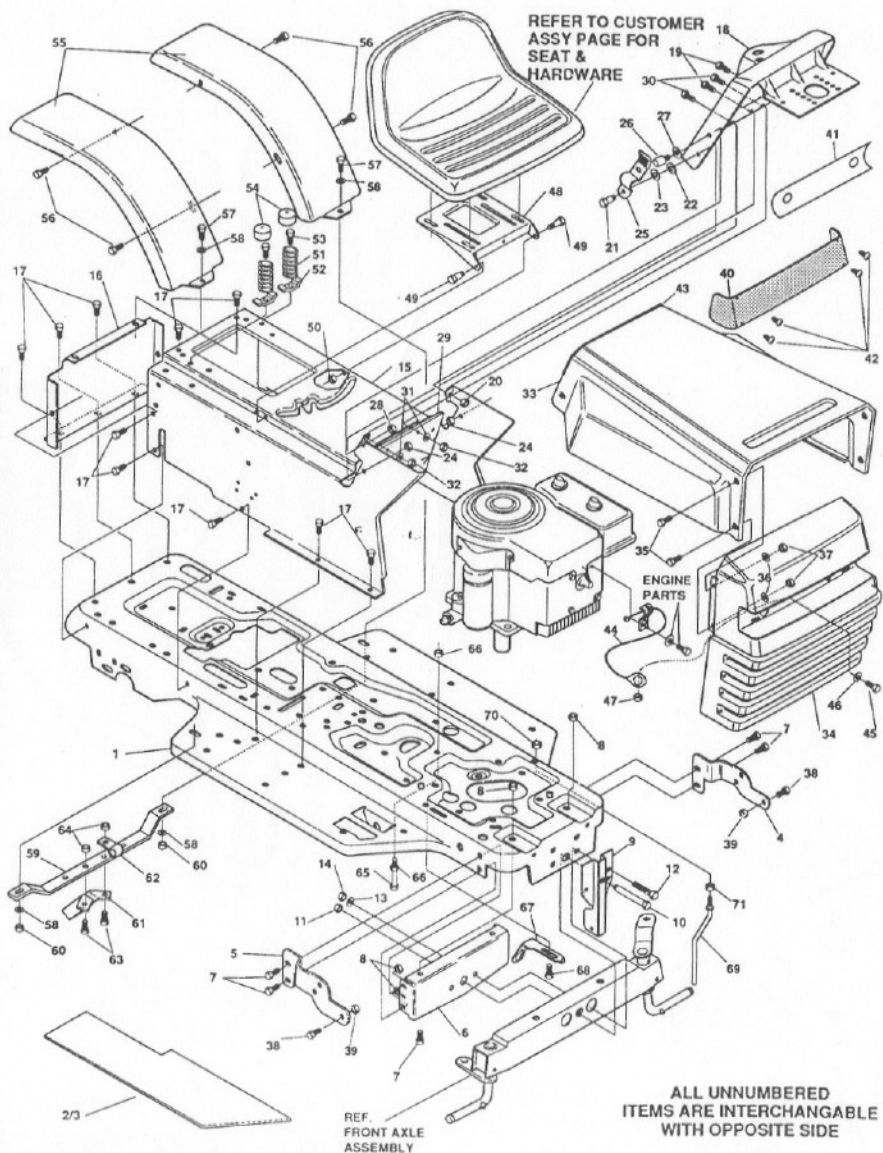

OTE: ALWAYS USE ORIGINAL EQUIPMENT PARTS. Use of service/replacement parts other than original equipment parts may void your warranty.

317708A

Part No. 318470

key#	part#	description	qty.
1	315066	FRAME, MAIN SF RIDER	1
2	302917	FOOTPAD, LH	1
3	302916	FOOTPAD, RH	1
4	316199	BRACKET, GRILLE L.H.	1
5	316200	BRACKET, GRILLE R.H.	1
6	313437	BRKT, SUPT FRT AXLE	1
7	056030	SCREW, 5/16-18X.75WDFLLK	6
8	055273	NUT, 5/16-18 HXWDFLLK	6
9	317507	HANGER BRKT	1
10	50720	BOLT, .625X2.875 SPSH 1/2-20	1
11	0274654	NUT, 1/2-20 REGHXCTRLLK	1
12	0122201	SCREW, 3/8-16X2.75 HHC	4
13	2483	WASHER, 39IDX1.25DX.07 BELLVIL	4
14	01499	NUT, 3/8-16 REGHXCTRLLK	4
15	309751	CONSOLE, SF DYNA STYLE TOPSH	4
16	8521	CONSOLE, REAR COVER	1
17	0995346	SCREW, 1/4-20X .50 WAHTAP	15
18	316113	DASH, SF NOMA DYNA STYLING	1
19	0995338	SCREW, 1/4-20X .63 HHWATAP	2
20	50352	NUT, 1/4-20 WDFLLK TOP LOCK	2
21	8482	BOLT, .375X .156 HSSH 5/16-18	2
22	0120394	WASHER, FLAT .406X .81X.065	2
23	0120393	WASHER, FLAT .344X .69X.065	2
24	01498	NUT, 5/16-18 REGHEXCTRLLK	2
25	57159	LATCH, .94WDX.047 ASSY HOOD	2
26	53448	PIN, 5/16-18 HOOD LATCH	2
27	0138538	WASHER, REGINTLK 320X.61X.03	2
28	045174	NUT, 5/16-18 HEXWDFLLK WHIZ	2
29	312306	BAFFLE CONSOLE SOUND EXPORT	2
30	0300314	SCREW, 1/4-20X .88WAHTAP	2
31	0120393	WASHER, FLAT .344X .69X.065	2
32	01502	NUT, 1/4-20 REGHEXCTRLLK	2
33	316489	HOOD	1
34	314476	GRILLE DYNA-PRO	1
35	0274672	SCREW, 1/4-20X .63 WAHHC	4
36	0120392	WASHER, FLAT .281X .63X.065	4
37	01502	NUT, 1/4-20 REGHEXCTRLLK	4
38	36149	BOLT, .375X .500 HSSH 5/16-18	2
39	01498	NUT, 5/16-18 REGHEXCTRLLK	2
40	302333	LENS HEADLAMP	1
41	314948	FOIL, LENS DYNA-PRO REFLECTOR	1
42	057796	SCREW, #6 X .50 PLASTITE	4
43	47453	EDGING, WIDE BLK	1
44	310749	LANYARD, HOOD	1
45	121887	SCREW, 1/4-20 X .75 HHC	1
46	120392	WASHER, FLAT .281 X .63 X .065	1
47	1502	NUT, 1/4-20 REG HEXCTRLLK	1
48	305857	PLATE, SEAT F-5 SF & LF	1
49	20507	BOLT, .437X .156 HSSH 5/16-18	2
50	01498	NUT, 5/16-18 REGHEXCTRLLK	2
51	56220	SPRING, 1.43X2.38X.162 COM SEAT	2
52	1341	CLAMP, SPRING 1.17"ID	2
53	0995346	SCREW, 1/4-20X .50 WAHTAP	2
54	302099	SPRING COVER SF SEAT SPG	2
55	3606	FENDER	2
56	0995346	SCREW, 1/4-20X .50 WAHTAP	4
57	0122017	SCREW, 5/16-18X1.00 HHC	4
58	0446363	WASHER, FLAT .375X .88X.082	4
59	43964	SUPPORT, GUIDE	1
60	01498	NUT, 5/16-18 REGHEXCTRLLK	2
61	314876	BRACKET, DECK GUIDE	1
62	57569	RETAINER, 3"ID X .62 X .03 WIRE	1
63	122017	SCREW, 5/16-18 X 1.00 HHC	2
64	1498	NUT, 5/16-18 REGHEXCTRLLK	2
65	049930	SCREW, 3/8-16X.75 HHC	2
66	01499	NUT, 3/8-16 REGHXCTRLLK	1
67	312953	BRACKET, SWITCH MOUNT	1
68	0995346	SCREW, 1/4-20X .50 WAHTAP	1
69	50653	GUIDE, BELT	1
70	041529	NUT, 3/8-16 HXCTRLLKJAM	1
71	0271190	NUT, 3/8-16 HEXKEPS	1
72	12563C	OPERATOR'S MANUAL (NOT ILLUSTRATED)	1
73	318470	PARTS MANUAL (NOT ILLUSTRATED)	1

◊ Indicates STANDARD HARDWARE ITEMS

Part No. 318470

106728

CUSTOMER ASSEMBLY

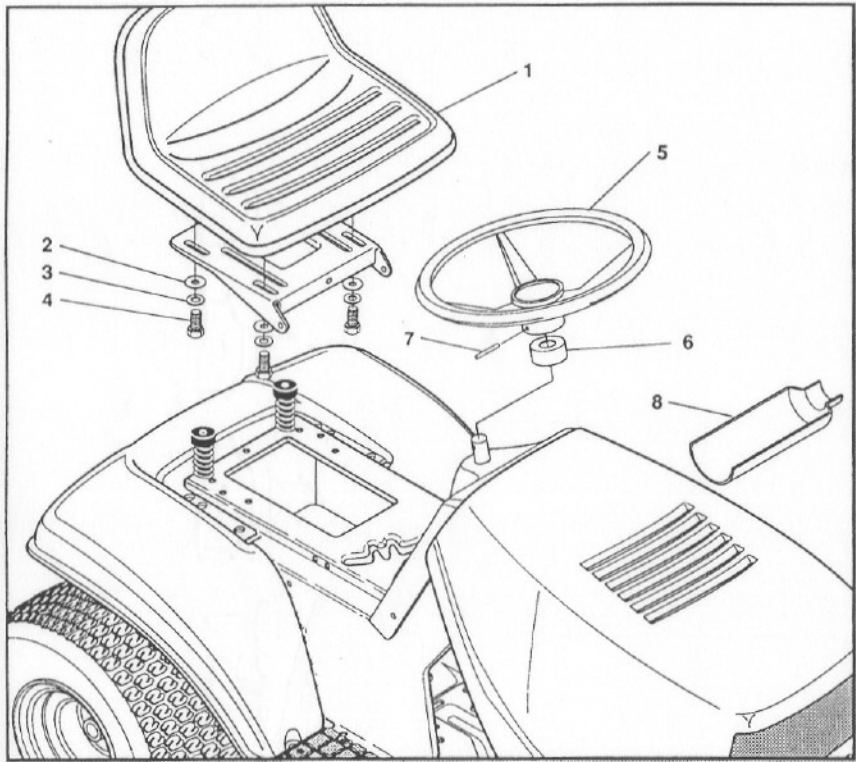

CUSTOMER ASSEMBLY VIEW

315134 PARTS BAG ASSY QTY1

key#	part#	decription	qty
1	57452	SEAT MV350	1
2	120393	WASHER,FLAT .344X.69X.065	4
3	120638	WASHER, HV SPLTLK .328X.60X.109	4
4	122007	SCREW, 5/16-18X.75 HHC	4
5	301251	STEERING WHEEL	1
6	314775	STEERING, SLEEVE	1
7	456378	ROLL PIN .250DIA X2.0LG	1
8	54873	OIL TROUGH	1

316235

Part No. 318470

TREAD PATTERNS

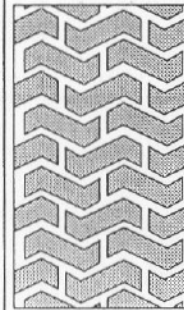

"A"

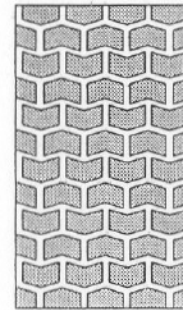

"B"

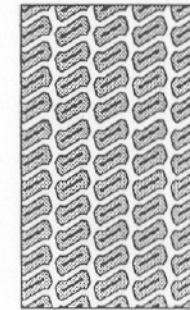

"C"

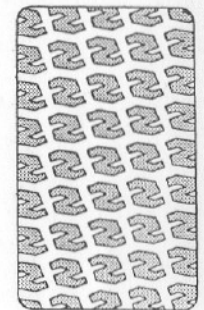

"D"

TIRE SIZE

	"A"	"B"	"C"	"D"
11 X 4.00 - 5	42295			
13 X 5.00 - 6	41060			
15 X 6.00 - 6	301140	316702	39830	313952
16 X 6.50 - 8		41081		314539
18 X 6.50 - 8				
18 X 9.50 - 8		316701		313950
20 X 8.00 - 8	314584			
20 X 10.00 - 8	58276			313565
20 X 10.00 - 10		55893		
23 X 9.50 - 12	314370			
23 X 9.50 - 12		53655		

316711 A

106 728

STEERING ASSEMBLY

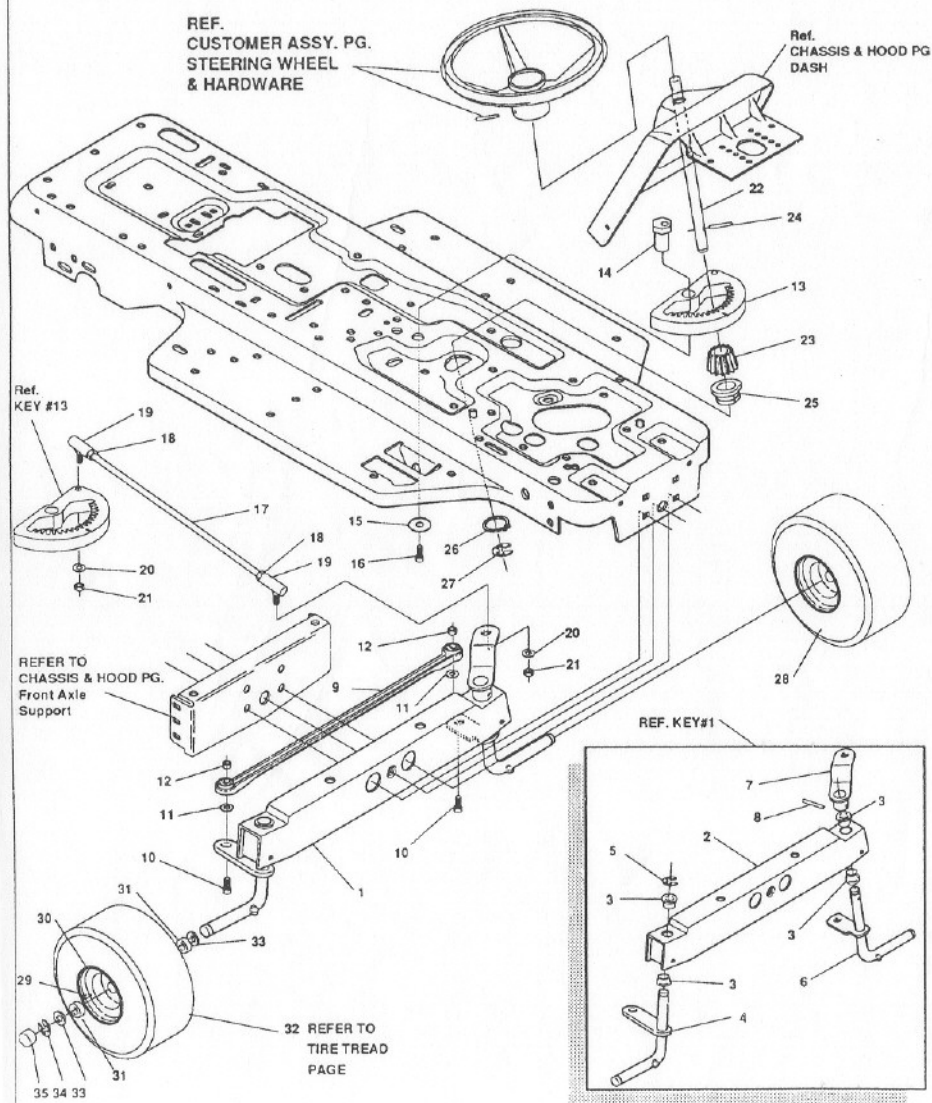

ALL UNNUMBERED ITEMS ARE INTERCHANGABLE WITH OPPOSITE SIDE

NOTE: ALWAYS USE ORIGINAL EQUIPMENT PARTS. Use of service/replacement parts other than original equipment parts may void your warranty.

315005B

Part No. 318470

key#	part#	description	qty.
1	*	FRONT AXLE ASSEMBLY SF	1
2	56400	AXLE, FRONT	1
3	50546	BEARING, FLANGE	4
4	310368	SPINDLE, RH	1
5	36625	RING, RETEX	1
6	310367	SPINDLE, LH	1
7	49447	ARM, STEERING LH	1
8	454565	PIN, SPRING	1
9	302691	TIE ROD	1
10	◇ 122145	SCREW, 3/8-16X1.25 HHC	2
11	◇ 120382	WASHER, .393X.68X.10 REGSPTLK	2
12	◇ 1499	NUT, 3/8-16 REGHCTRLK	2
13	304245	SECTOR, GEAR	1
14	44011	BOLT, .750X1.40 SPSH	1
15	2483	WASHER, .391DX1.25CDX.07	1
16	39573	SCREW, 3/8-24X1.00 NYL	1
17	56190	DRAG LINK	1
18	◇ 124925	NUT, 3/8-24 REGHEXJAM	2
19	21275	BALL JOINT	2
20	◇ 120382	WASHER, REGSPTLK	2
21	◇ 120369	NUT, 3/8-24 REGHEX	2
22	314109	STEERING SHAFT	1
23	44009	PINION, STEERING SHAFT	1
24	454565	PIN, SPRING	1
25	54902	BEARING, 1.370X.50 FLANGE STEERING	1
26	39492	RING, RETEX 1.27X.05	1
27	36625	RING, RETEX .57X.05	1
28	*	ASSEMBLY, TIRE & RIM	2
29	24167	VALVE STEM	1
30	39937	WHEEL W/BEARING	1
31	39979	BEARING, 1.380DX.753ID FLANGE	2
32	*	REFER TO TIRE TREAD PAGE	
33	642	WASHER, FLAT .755X1.31X.075	4
34	35825	RING, RETEX .57X.05	2
35	40394	HUB CAP	2

* Order Individual Parts
 ◇ Indicates STANDARD HARDWARE ITEMS.

Part No. 318470

106 728

MOTION DRIVE ASSEMBLY

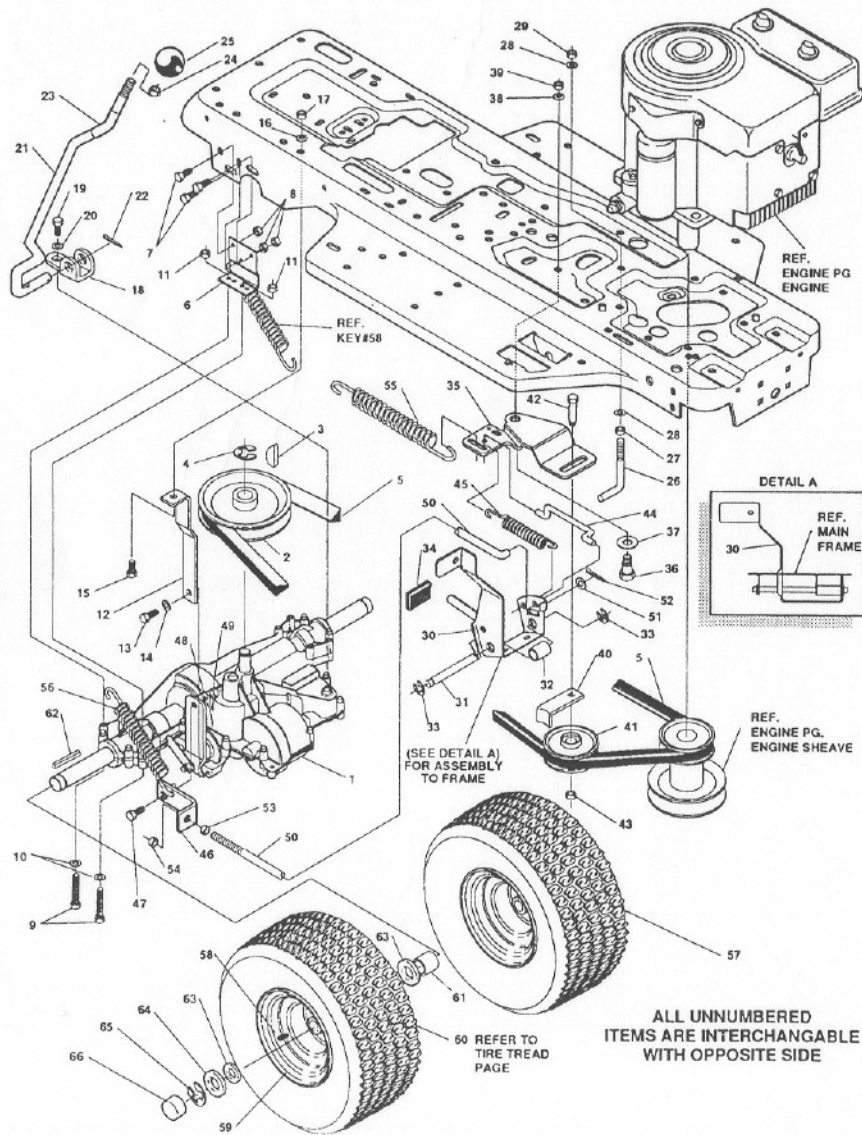

315367B

Part No. 318470

key#	part#	description	qty.
1	TRANSAXLE	CONTACT NEAREST DEALER	1
2	302745	PULLEY	1
3	3021	KEY, WDRF 606 .75X.187X.312	1
4	22053	RING, RETEX	1
5	54758	BELT	1
6	7707	BRACKET, TRANSAXLE	2
7	0120228	SCREW, 5/16-18X.63 HHC	6
8	01498	NUT, 5/16-18 REG H CTR LK	6
9	0180112	SCREW, 5/16-18X2.75	4
10	0120393	WASHER, FLAT .344X.69X.065	4
11	01498	NUT, 5/16-18 REG H CTR LK	4
12	309770	BRACKET, STABILIZER	1
13	35498	SCREW, 5/16-18X.75 WA H TAP	1
14	0120638	WASHER, 328X.60X.09 HVSPTLK	1
15	0122017	SCREW, 5/16-18X1.00 HHC	1
16	0138485	WASHER EXLK .320X.61X.03	1
17	01498	NUT, 5/16-18 REG H CTR LK	1
18	57480	BRACKET, SHIFT LEVER	1
19	056255	SCREW, 1/4-28X.75 NYLHH	1
20	057157	WASHER, 750X.250	1
21	302283	SHIFT LEVER	1
22	137185	PIN, COTTER .125 DIA 1.00 LG	1
23	302445	PLASTIC TUBE	1
24	0120238	NUT, 1/2-13HEXJAM	1
25	304438	KNOB, SHIFT	1
26	49896	GUIDE, BELT	1
27	0271184	NUT, 5/16-18 HEXKEPS	1
28	0120393	WASHER, FLAT .344X.69X.065	2
29	01498	NUT, 5/16-18 REG H CTR LK	1
30	302603	ASSEMBLY, BRAKE PEDAL	1
31	302600	ROD, PIVOT	1
32	302601	SPACER	1
33	20864	RING, RETEX .39X.04	2
34	48761	PAD, BRAKE CLUTCH PEDAL	1
35	1306	BRACKET, IDLER ARM	1
36	41890	BOLT, .625X.218 HSSH	1
37	4107	WASHER, FLAT	1
38	045602	WASHER, FLAT .333X.87X.119	1
39	01498	NUT, 5/16-18 REG H CTR LK	1
40	39659	RETAINER, STRAP	1
41	35374	PULLEY, IDLER	1
42	45892	BOLT, 3/8-16X1.50 CARRIAGE	1
43	01499	NUT, 3/8-16 REG H CTR LK	1
44	43980	ROD, CLUTCH	1
45	50562	SPRING	1
46	54723	BRACKET, BRAKE ROD	1
47	20507	BOLT, .437X.156 HSSH	1
48	0120393	WASHER, FLAT .344X.69X.065	1
49	01498	NUT, 5/16-18 REG H CTR LK	1
50	310189	ROD, BRAKE	1
51	0120393	WASHER, FLAT .344X.69X.065	1
52	121222	PIN, COTTER	1
53	0271184	NUT, 5/16-18 HEXKEPS	1
54	01498	NUT, 5/16-18 REG H CTR LK	1
55	49276	SPRING	1
56	35410	SPRING, .071X.62X4.37	1
57	*	TIRE AND RIM ASSEMBLY	2
58	24167	VALVE STEM	1
59	36182	WHEEL	1
60		REFER TO TIRE TREAD PAGE	
61	57479	SPACER, .75X1.25X1.32	2
62	39528	KEY, SQUARE	2
63	642	WASHER, FLAT .755X1.31X.075	4
64	42815	WASHER, FLAT .755X1.53X.07	2
65	36825	RING, RETEX .57X.05 TRL	2
66	40394	CAP, HUB 1.500IDX7/8 LG	2

* Order Individual Parts.
 0 Indicates STANDARD HARDWARE ITEMS.

Part No. 318470

106728

ENGINE & CONTROL ASSEMBLY

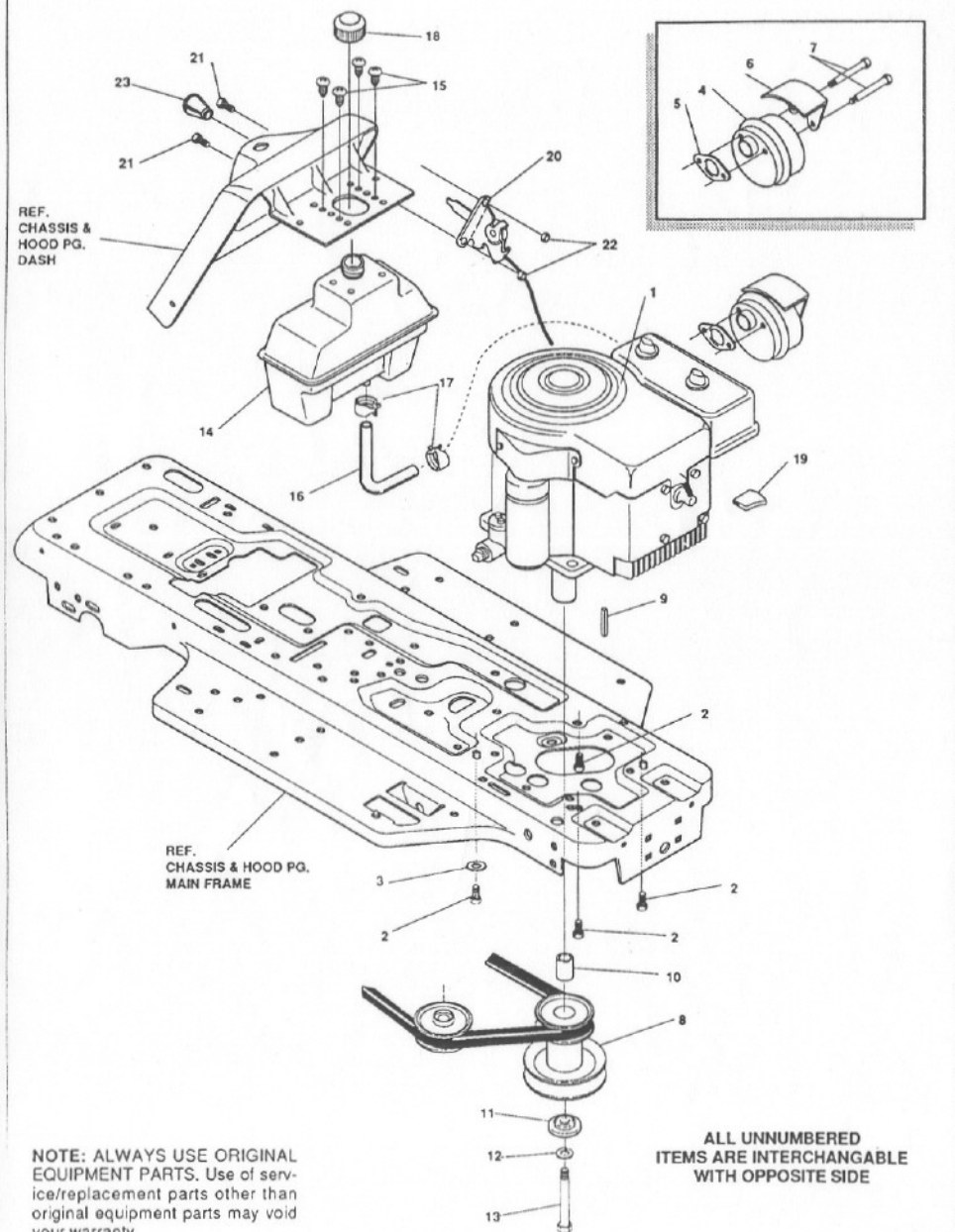

317058B

Part No. 318470

key#	part#	description	qty.
1	ENGINE	10B&S VER ELEC RER (SEE ENGINE MANUAL)	1
2	50947	SCREW, 3/8-16X1.25 WAHHTAP	4
3	138489	WASHER, EXLK 384X 69X.04	1
4	305367	MUFFLER-LO TONE NELSON EXPORT	1
5	46708	GASKET, MUFFLER	1
6	54767	SHIELD, HEAT, FOR ROUND MUFFLER	1
7	173063	SCREW, 5/16-18X3.50 HHC	1
8	315317	PULLEY, ENG 3.0D X 4.0LG X 5.0D	1
9	303151	KEY, SQUARE .249SOX4.50LG	1
10	304246	SPACER, 1.01X1.484 ENGIN PULLEY	1
11	56431	WASHER, 980IDX1.380DX.437PILOT	1
12	120383	WASHER, REGSPTLK.459X.78X.12	1
13	433146	SCREW, 7/16-20X4.25 HHC BLK PH	1
14	314989	TANK, FUEL 1 GAL	1
15	49050	SCREW, 1/4-10X .75PHPNTAPGR2BK	4
16	47452	GAS LINE .25ID BULK LENGTH	12IN
17	48672	CLAMP, FUEL LINE	2
18	46704	GAS CAP 1-1/2-7 THD BLK	1
19	302967	ENGINE SPEED REDUCER	1
20	303275	THROTTLE CONTROL	1
21	35291	SCREW, 10-24X .50 SLHHMA	1
22	271166	NUT, #10-24 HEXKEPS	2
23	50607	KNOB, ROUND THROTTLE	2

0 Indicates STANDARD HARDWARE ITEMS.

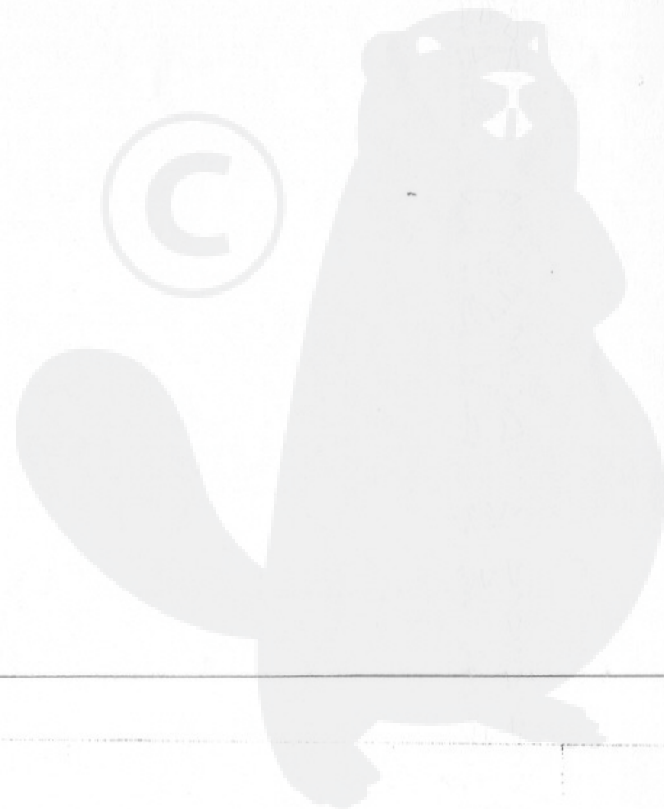

Part No. 318470

106728

PRE-PAINTED DECK

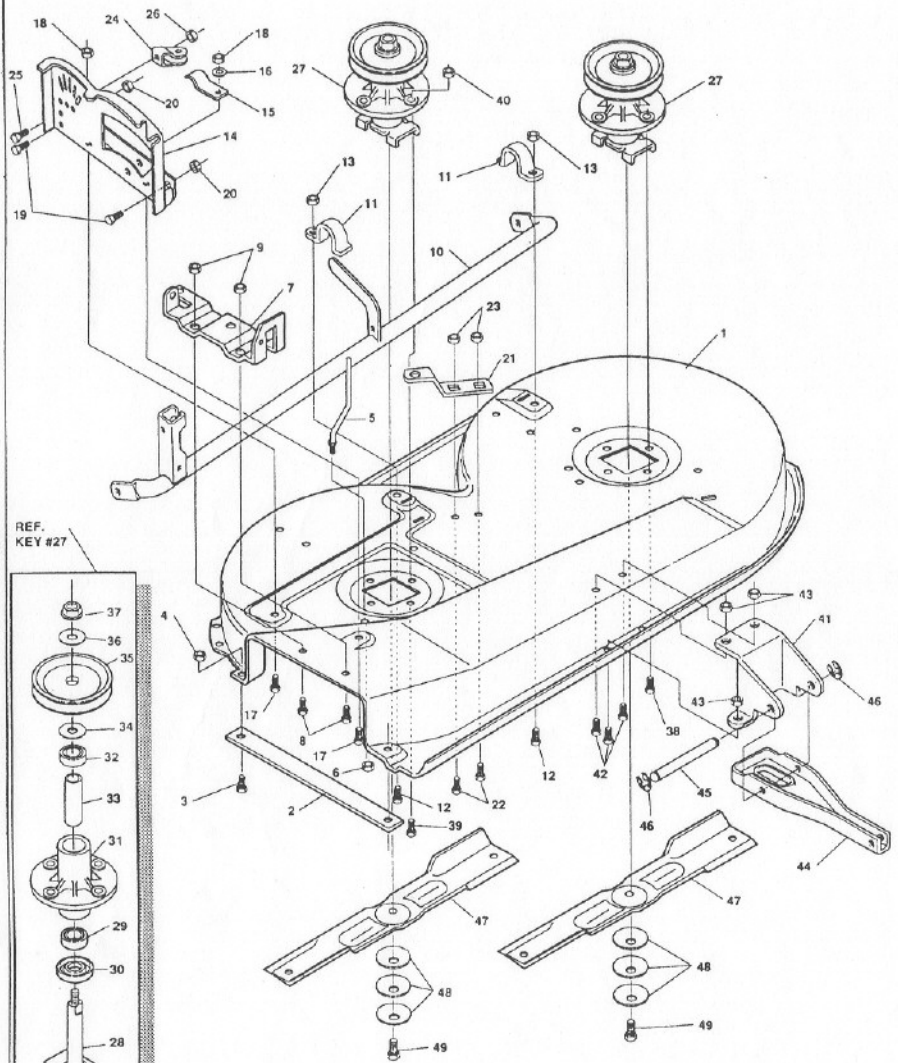

REF. KEY #27

NOTE: ALWAYS USE ORIGINAL EQUIPMENT PARTS. Use of service/replacement parts other than original equipment parts may void your warranty.

ALL UNNUMBERED ITEMS ARE INTERCHANGABLE WITH OPPOSITE SIDE

317024A

Part No. 318470

key#	part#	description	qty.
1	310243	Deck	1
2	57314	Bar, Skid	1
3	0 126216	Bolt, 5/16-18 x .75 Carr. GR2	2
4	0 271184	Nut, 5/16-18 Hex Keps	2
5	57318	Guide, Belt 5/16-18 Thd.	1
6	0 1498	Nut, 5/16-18 Reg Hex Ctr Lk	1
7	57360	Bracket, Chute	1
8	0 120834	Screw, 5/16-18 x .50 H HC GR2	2
9	0 1498	Nut, 5/16-18 Reg Hex Ctr Lk	2
10	306881	Tube, 36" Assy Torgue	1
11	51985	Support, Pivot Tube	1
12	0 120228	Screw, 5/16-18 x .63 H HC GR2	1
13	0 1498	Nut, 5/16-18 Reg Hex Ctr Lk	1
14	57337	Quadrant, Height Adj.	1
15	57321	Spring, Clutch Handle Retain	1
16	120386	Washer, Flat .312 x .73 x .065	1
17	122007	Screw, 5/16-18 x .75 H HC GR2	2
18	0 1498	Nut, 5/16-18 Reg Hex Ctr Lk	2
19	0 122040	Screw, 5/16-18 x 1.50 H HC GR2	2
20	0 1498	Nut, 5/16-18 Reg Hex Ctr Lk	2
21	0 300179	Bracket, Idler Support	1
22	0 180077	Screw, 5/16-18 x .75 H HC GR5	2
23	44108	Nut, 5/16-18 Hwd Fl Lk Whiz	2
24	0 49320	Cable, Pulley Support	1
25	0 120228	Screw, 5/16-18 x .63 H HC GR2	1
26	1498	Nut, 5/16-18 Reg Hex Ctr Lk	1
27	0 56424	Quill Assy, 36", 38", 39", & 40"	2
28	0 56425	Shaft/Saddle 36"	1
29	49562	Ball Bearing	1
30	50616	Dust Shield	1
31	55547	Quill Casting (1046)	1
32	49562	Ball Bearing	1
33	50818	Spacer, 3.797 LG x .669 ID x .88 OD	1
34	51449	Spacer, .438 LG x .932 OD x .672 ID-PM	1
35	56390	Pulley, 25/36" Quill V5L	1
36	56365	Special Washer	1
37	1282	Nut, 7/16-20 Wd Fl Lk	1
38	50634	Screw, 5/16-18 x .88 Wa H H Tap	7
39	300345	Screw, 5/16-18 x 1.38 Wa Tap GR2	1
40	1498	Nut, 5/16-18 Reg Hex Ctr Lk	1
41	57327	Bracket, Front	1
42	0 120228	Screw, 5/16-18 x .63 H HC GR2	4
43	1498	Nut, 5/16-18 Reg Hex Ctr Lk	4
44	0 57340	Bracket, Front Lift	1
45	0 57196	Rod, Pivot	1
46	20864	Ring, Ret E. .39 x .04 Trus 5133-50	2
47	56821	Blade	2
48	2483	Washer, 39ID x 1.25D x .07 Bellvil	6
49	39573	Screw, 3/8-24 x 1.00 Nyl H HC GR5	2

0 Indicates STANDARD HARDWARE ITEMS.

Part No. 318470

106728

FINAL DECK ASSEMBLY

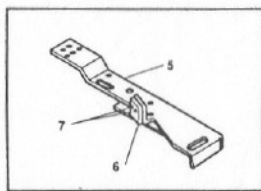

Ref. KEY # 4

SEE DWG#317024 FOR PARTS ASSY OF PRE-PAINTED DECK

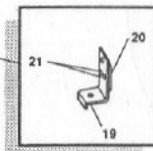

Ref. KEY # 18

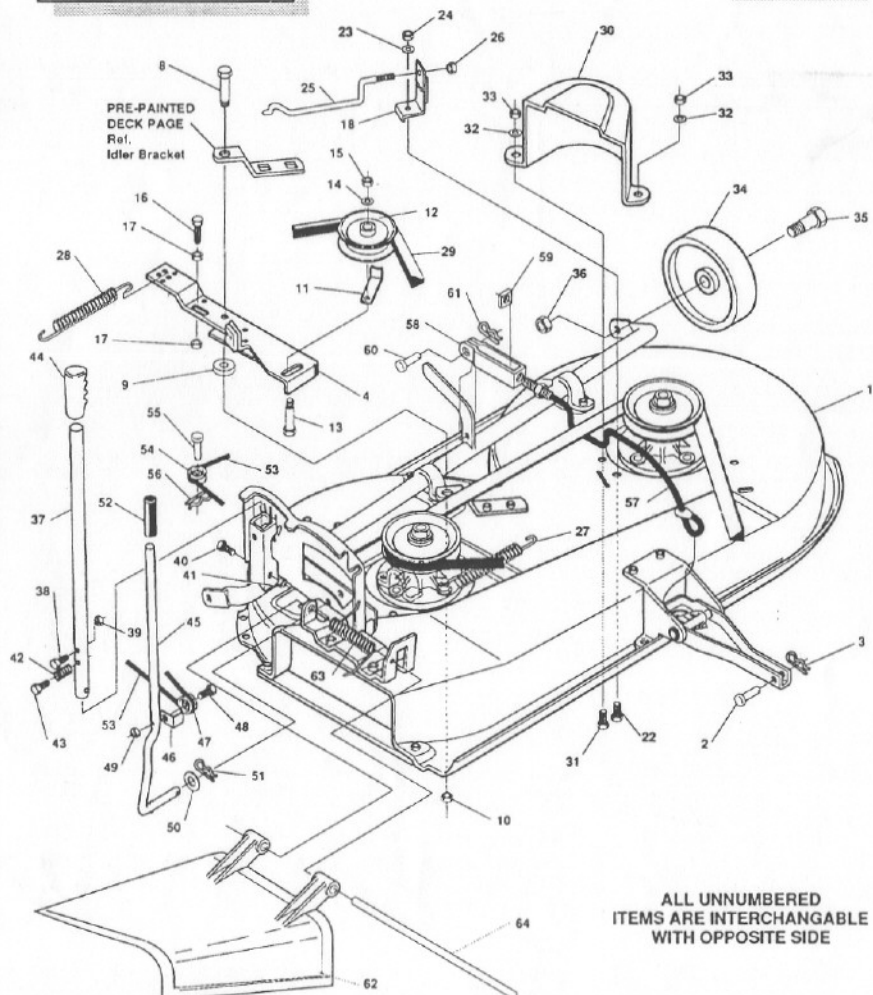

ALL UNNUMBERED ITEMS ARE INTERCHANGABLE WITH OPPOSITE SIDE

NOTE: ALWAYS USE ORIGINAL EQUIPMENT PARTS. Use of service/replacement parts other than original equipment parts may void your warranty.

317026A

key#	part#	description	qty.
1	*	DECK, 36SD ASSY PTD	1
2	47816	PIN, .495X1.750 CLEVIS-SHORT	1
3	56180	PIN, HAIR .091 DIA X1.62LG	1
4	300491	BRACKET, IDLER ARM/BRAKE	1
5	9282	IDLER ARM	1
6	306973	BRAKE PAD - HARD - 232AF	1
7	135624	RIVET, TRSET .185DIA X .41LG	2
8	300180	BOLT, .50 X1.88 HSSH 3/8-16	1
9	0996416	WASHER, FLAT .391X1.00X.125	2
10	045171	NUT, 3/8-16 HWDFL WHIZ-LOCK Z	1
11	1346	RETAINER,BELT	1
12	310326	PULLEY, IDLER BFF 4.00 WIDE FL	1
13	57325	BOLT, 3/8-16X2.00 CARR	1
14	0120382	WASHER, REGSPTLK.393X.68X.10 Z	1
15	0120377	NUT, 3/8-16 REGHX	1
16	0121954	SCREW, 1/4-20X2.00 HHC	1
17	0271172	NUT, 1/4-20 REGHEXKEPS	2
18	303247	ASSY.BLADE BRAKE	1
19	12542	BRAKE ARM B	1
20	306973	BRAKE PAD - HARD -	1
21	135624	RIVET, TRSET .185DIA X .41LG ST	2
22	120228	SCREW, 5/16-18X .63 HHC	1
23	0120393	WASHER, FLAT .344X .69X.065	1
24	01498	NUT, 5/16-18 REGHEXCTRLK	1
25	300315	ROD, BRAKE RELEASE 36&45 DECKS	1
26	01502	NUT, 1/4-20 REGHEXCTRLK	1
27	35410	SPRING .071 X .62 X 4.37	1
28	300683	SPRING, .75X6.3X.105 TENSION	1
29	302289	BELT, V 5L 73.75	1
30	302833	GUARD, BELT LH PLASTIC	1
31	0120228	SCREW, 5/16-18X .63 HHC	3
32	0120393	WASHER, FLAT .344X .69X.065	3
33	01498	NUT, 5/16-18 REGHEXCTRLK	3
34	52584	WHEEL, SD 6.00ODX1.38	2
35	23763	BOLT, .500X1.390 HSSH 3/8-16 Z	2
36	1499	NUT, 3/8-16 REGHXCTRLK	2
37	313637	LEVER, DECK HEIGHT ADJUST	2
38	57324	BOLT, 5/16-18X .55 SPCUHD LATCH	1
39	0271184	NUT, 5/16-18 HEXKEPS	1
40	0122040	SCREW, 5/16-18X1.50 HHC	1
41	01498	NUT, 5/16-18 REGHEXCTRLK	1
42	57319	SPRING, .70X .85X .091 COM HANDLE	1
43	0995346	SCREW, 1/4-20X .50 WAHTAP	1
44	56924	GRIP, .75 X 4.25 HANDLE	1
45	313636	LEVER, CLUTCH	1
46	1288	BRACKET,CABLE RETAINER	1
47	39298	PULLEY, .906X.305 NYLON	1
48	57322	BOLT, .375X .375 HSSH 1/4-20 Z	1
49	01502	NUT, 1/4-20 REGHEXCTRLK	1
50	0120396	WASHER, FLAT .531X1.06X.095	1
51	8260	PIN, HAIR .091 DIA X1.66LG	1
52	46478	GRIP, HAND .50ID 3.37LG BLK	1
53	57326	CABLE, CLUTCH 17.5"	1
54	39298	PULLEY, .906X.305 NYLON	1
55	49332	PIN, CLEVIS .375DX.81LG	1
56	121222	PIN, COTTER .090/.086X.75LG	1
57	300341	CABLE, LIFT 21.70 F-5 20X8-8	1
58	9405	CLEVIS, LIFT CABLE Z-PL	1
59	0120372	NUT, 1/4-20 REGSO	1
60	39522	PIN CLEVIS .312 X .812	1
61	56180	PIN, HAIR .091 DIA X1.62LG	1
62	57818	CHUTE DEFLECTOR	1
63	314975	SPRING TORSION CHUTE DEF.	1
64	57317	PIVOT ROD,CHUTE	1

* Order Individual Parts.
 ◊ Indicates STANDARD HARDWARE ITEMS.

106728

ELECTRICAL ASSEMBLY

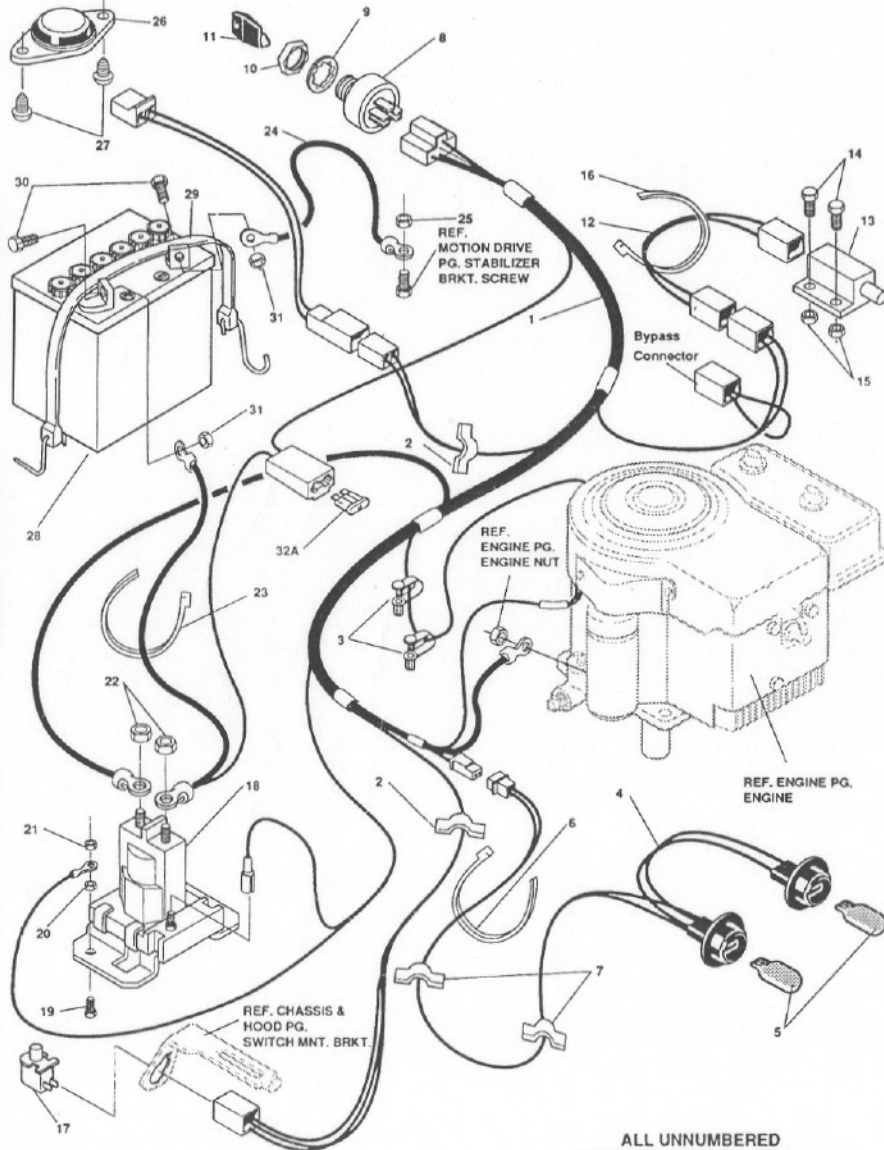

ALL UNNUMBERED
ITEMS ARE INTERCHANGABLE
WITH OPPOSITE SIDE

NOTE: ALWAYS USE ORIGINAL EQUIPMENT PARTS.
Use of service/replacement parts other than original equip-
ment parts may void your warranty.

313467B

Part No. 318470

key#	part#	description	qty.
1	57642	WIRE HARNESS	1
2	41482	CLIP, PRESS WIRE	2
3	54888	RETAINER, WIRE	2
4	303064	ASSY., LIGHT WIRE	1
5	52572	BULB, HEADLAMP	2
6	57444	TIE, CABLE	1
7	41482	CLIP, PRESS WIRE	2
8	300687	SWITCH, IGNITION & LIGHTS	1
9	138557	WASHER, REGINTLK	1
10	48140	NUT, 5/8-32 HXHD IGN SWIT	1
11	300626	KEY, IGNITION SWITCH	1
12	57588	HARNESS, DECK WIRE SHORT 4 WIRE	1
13	57476	SWITCH	1
14	159943	SCREW, 10-24 X .63 PHPNMA	2
15	271166	NUT, #10-24 HEXKEPS	2
16	57444	TIE, CABLE BLACK NYLON	1
17	300220	SWITCH, SNAPMNT NO.055/116	1
18	53716	SOLENOID, NEW CLUM	1
19	187745	SCREW, 1/4-20 X .75 HXSEMMA	2
20	1502	NUT, 1/4-20 REGHEXCTRLK	2
21	271172	NUT, 1/4-20 HEXKEPS	1
22	271187	NUT, 5/16-24 H KEPS	2
23	57444	TIE, CABLE	1
24	55511	WIRE, GROUND	1
25	271184	NUT, 5/16 - 18 HEXKEPS	1
26	57547	SWITCH, SEAT	1
27	160505	SCREW, 1/4-20 PNPNHM	2
28	57486	BATTERY, 12V 5 PLATE	1
29	309862	STRAP, RUBBER	1
30	120854	SCREW, 1/4-20 X .63 HHC	2
31	271172	NUT, 1/4-20 H KEPS	2
32A	**302031	FUSE, 15 AMP SHADE TYPE	1
32B	**49211	FUSE, 15 AMP CYLINDRICAL TYPE	1

0 Indicates STANDARD HARDWARE ITEMS.
**Cylindrical or Spade type fuses are included with the wire harness.

Part No. 318470