

REPAIR PARTS MANUAL

43" - 12 H.P. LAWN TRACTOR

MODEL B3560-740

ONE YEAR LIMITED WARRANTY

For one (1) year from date of purchase by the first consumer for residential use (thirty (30) days commercial use), NOMA Outdoor Products Incorporated warrants that it will replace free of charge, including labor, any original part of any NOMA Outdoor Products Incorporated product found to be defective by any authorized Service Dealer or the factory, except the battery which is warranted for ninety (90) days from date of purchase.

This warranty does not cover engine, transmission, transaxle or differential (these items are covered by their manufacturer's own warranty). This warranty does not cover parts that have failed due to normal wear or parts that have failed subject to misuse or abuse. Transportation of the unit or part to and from an authorized Service Dealer or factory is the responsibility of the owner.

A step by step explanation as to what procedure should be followed for this warranty is:

1. If a part becomes defective, contact the store where the unit was purchased for the name and address of the authorized Service Dealer nearest to you.
2. If you cannot locate an authorized Service Dealer, write Service Department of NOMA Outdoor Products Incorporated for the name and address of the authorized Service Dealer in your area or call the Service Department at 1-901-422-1690.
3. Return the defective product, along with proof of purchase to such authorized Service Dealer for replacement of any defective part where covered by this warranty.

There is no other express warranty. Implied warranties, including those of merchantability and fitness for a particular purpose are limited to one (1) year from date of purchase. Liability for incidental or consequential damages are excluded.

Some states do not allow limitations on how long an implied warranty lasts, so the above limitation may not apply to you. Some states do not allow the exclusion of incidental or consequential damages, so the above exclusion may not apply to you. This warranty gives you specific legal rights, and you may have other rights which vary from state to state.

NOMA Outdoor Products Incorporated

Caller 8000

Jackson, TN 38308-8000

UNIT PARTS AND SERVICE

This manual contains instructions for safety, assembly and maintenance. Read this manual carefully and completely so that you will know proper assembly, use and care of your unit. Also fill in and mail the registration card packed with the unit. For service other than covered in this manual, contact an authorized service dealer. A nationwide parts and service organization has been established to provide locally available parts and service. A list of authorized parts distributors has been included in this manual. When ordering repair parts, always give the following information: 1. The Part Name; 2. The Part Number; 3. The Quantity desired; 4. The Full (eight digit) Model Number of the unit. The model number will be found on a plate attached to the unit.



Look for this symbol. It means - ATTENTION! BECOME ALERT! A HAZARD TO OPERATOR, BYSTANDER, PROPERTY OR EQUIPMENT MAY EXIST.

NOMA Outdoor Products Incorporated
Caller 8000
Jackson, TN 38308-8000

Part No. 318140

0291



OPERATIONAL PRECAUTIONS



THESE INSTRUCTIONS ARE FOR YOUR PROTECTION. PLEASE READ THEM CAREFULLY.

1. Know the controls and how to stop quickly. READ THIS OPERATOR'S MANUAL and instructions furnished with attachments.
2. Wear safety glasses or eye shields when assembling or operating riding mower.
3. Do not allow children to operate the machine. Do not allow adults to operate it without proper instruction.
4. Do not carry passengers. Do not mow when children and others are around. Disengage power to blade(s) or attachment(s) and stop the engine while others are in the vicinity of the mower.
5. Battery fluid (electrolyte) is an ACID and is extremely dangerous. Do not smoke while servicing the battery. Do not service the battery near a open flame or spark.
6. Handle gasoline with care, it is highly flammable.
 - A. Use approved gasoline container.
 - B. Never remove the fuel cap of, or add gasoline to, a running or hot engine, or an engine that has not been allowed to cool for several minutes after running. Never fill the tank indoors and always clean up spilled fuel immediately.
 - C. Do not smoke while filling fuel tank.
 - D. Do not run the engine indoors. Open doors if engine must be run in garage. Exhaust fumes contain CARBON MONOXIDE, an ODORLESS and DEADLY GAS.
7. Check fuel supply before each use allowing space for expansion as the heat of the engine and/ or sun can cause gasoline to expand.
8. Do not operate mower when barefooted. Always wear substantial footwear, preferably steel-toed shoes. Do not wear loose fitting clothing that could get caught in moving parts.
9. Clear the work area of objects (wire, rocks, etc.) which might be picked up and thrown. Check all controls for proper function.
10. Disengage all attachment clutches, shift to neutral, and set parking brake before attempting to start the engine (motor). When starting engine equipped with a pull starter, stand firm and make sure your feet are well away from the blade(s).
11. Disengage power to blade(s) or other attachment(s) and stop the engine (motor) before leaving the operator's position. Always dismount from the left side.
12. Disengage power to blade(s) or other attachment(s) and stop the engine (motor) before making any repairs or adjustments.
13. Disengage power to blade(s) or other attachment(s) when transporting or not in use.
14. Take all possible precautions when leaving the vehicle unattended, such as disengaging power to blade(s) or attachment(s), lower the attachment(s), setting the parking brake, stopping the engine (motor), and removing the key.
15. Do not stop or start suddenly when going uphill or downhill. Mow up and down the face of steep slopes; never across the face.
16. Reduce speed and exercise extreme caution on slopes and in sharp turns to prevent tipping or loss of control. Be especially cautious when changing direction on slopes.
17. Stay alert for holes, rocks, and roots in the terrain and other hidden hazards. Keep away from drop-off. Never operate your riding mower on wet or slippery grass or at a speed which could cause a skid. Exercise care when mowing around a fixed object to prevent the blade(s) from striking it. Never deliberately run over any foreign object.
18. Always disengage blade control lever before attempting to remove the mower from a hole or other obstruction.
19. Use care when pulling loads or using heavy equipment.
 - A. Use only approved drawbar hitch points.
 - B. Limit loads to those that you can safely control.
 - C. Do not turn sharply. Use care when backing.
 - D. Use counterweight(s), wheel weights or tire chains when suggested in attachment(s) instructions.
20. Watch for traffic when crossing or near roadways.
21. When using attachment(s), never direct discharge of material toward bystanders nor allow anyone near the vehicle while in operation.
22. Keep the vehicle and attachments in good operating condition, and keep safety devices in place and in working condition.
23. Keep all nuts, bolts, and screws tight to be sure the equipment is in safe working condition.
24. Never store the equipment with gasoline in the tank inside a building where fumes may reach an open flame or spark. Allow the engine to cool before storing in any enclosure.
25. To reduce fire hazard, keep the engine free of grass, leaves or excessive grease.
26. The vehicle and attachments should be stopped and inspected for damage after striking a foreign object, and the damage should be repaired before restarting and operating the equipment.
27. Do not change the engine governor settings or over-speed engine.
28. When using the vehicle with mower, proceed as follows:
 - A. Mow only in daylight or in good artificial light.
 - B. Never make a cutting height adjustment while the engine (motor) is running if the operator must dismount to do so.
 - C. Shut the engine (motor) off when removing the grass catcher or unclogging chute.
 - D. Check the blade mounting bolts for proper tightness at frequent intervals.
29. Under normal usage, the grass catcher bag material is subject to deterioration and wear. Check the bag frequently for deterioration and wear and replace worn bags. Check that replacement bags comply with the original manufacturer's recommendations or specifications.
30. Disengage power to mower before backing up. Do not mow in reverse unless absolutely necessary and then only after careful observation of the entire area behind the mower.

OWNER'S INFORMATION

Record the following information about your unit so that you will be able to provide it in case of loss or theft.

MODEL NUMBER: - (Enter complete 8 digit number from model plate on unit)
PURCHASE DATE: ___ / ___ / ___ CODE NO.: _____ SERIAL NO.: _____
DEALER'S NAME AND ADDRESS: _____
CITY: _____ STATE: _____ TELEPHONE: _____

CONTENTS OF SHIPPING CARTON

- 1 - Lawn Tractor
- 1 - 43 inch Mower Deck
- 1 - Operator's Manual
- 1 - Repair Parts Manual
- 1 - Engine Manual
- 1 - Steering Wheel (see Note)
- 1 - Seat (see Note)
- 2 - Front Tired (see Note)

1 - Bag of Assembly Parts Containing (see Note)

- 1 - Spring Pin
- 1 - Oil Drain Trough
- 4 - 5/16 x 3/4 inch Hex Head Screws
- 4 - 5/16 inch Split Lockwashers
- 4 - 11/32 inch Flatwashers
- 1 - Steering Shaft Cover
- 1 - Shift Knob
- 4 - 5/64 inch Flatwashers
- 2 - E-Rings
- 2 - Hub Caps
- 1 - Torsion Spring
- 1 - Pivot Rod
- 1 - Push Nut
- 2 - 3/8-16 Locknuts
- 2 - Shoulder Bolts 3/8-16
- 2 - Deck Wheels

NOTE: Refer to page 24 & 25 (Customer Assembly Parts) for more detailed description.

TOOLS REQUIRED FOR ASSEMBLY

- 2 - 7/16 inch Wrenches (or adjustable wrench)
- 1 - 1/2 inch Wrench (or adjustable wrench)
- 1 - Small Phillips Screwdriver with a 1/4 inch shank
- 1 - Hammer

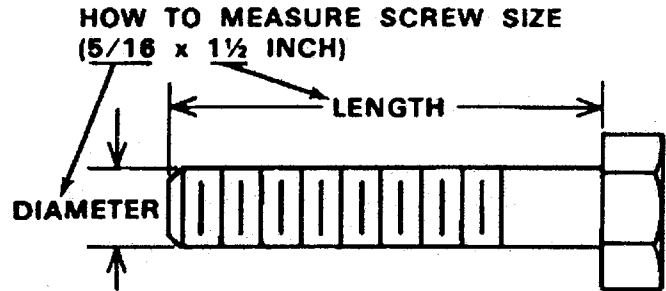

DANGER



This lawn tractor can be dangerous if carelessly used.

Read your Operator's Manual thoroughly before operating your lawn tractor.

Always wear safety glasses or eye shields while assembling or operating your lawn tractor.

DO NOT carry passengers at any time.

Keep your hands, feet, hair and loose clothing away from the discharge area, the underside of the mower deck or any moving parts while the engine is running.

DO NOT allow children or young teenagers to operate or be near your lawn tractor while it is operating.

ALWAYS GIVE THE FOLLOWING INFORMATION WHEN ORDERING REPAIR PARTS:

1. The PART NUMBER; 2. The PART NAME; 3. QUANTITY DESIRED; 4. The MODEL NUMBER (As shown on Model Plate).

SEND PART ORDERS AS PER INSTRUCTIONS ON THE FRONT PAGE.

DO NOT USE KEY NUMBERS WHEN ORDERING REPAIR PARTS, ALWAYS USE PART NUMBERS.

All replacement parts will be supplied in current production colors or in a neutral color.

A handling fee is applicable to small parts orders.

YOUR UNIT IS RIGHT HAND (RH) OR LEFT HAND(LH) AS YOU STAND BEHIND IT.

43" LAWN TRACTOR MODEL B3560-740

CHASSIS & HOOD ASSEMBLY

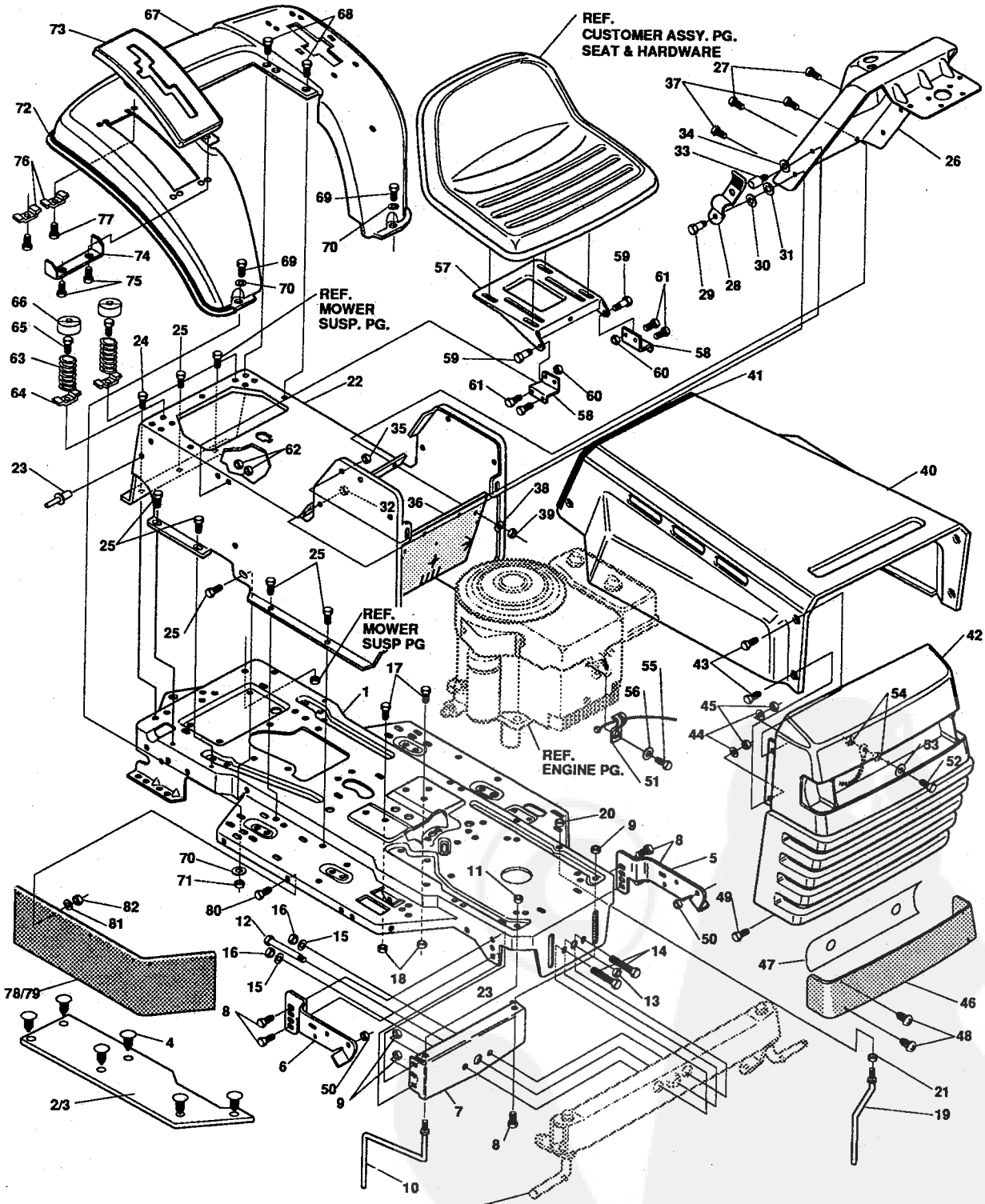

NOTE: ALWAYS USE ORIGINAL EQUIPMENT PARTS. Use of service/replacement parts other than original equipment parts may void your warranty.

ALL UNNUMBERED ITEMS ARE INTERCHANGABLE WITH OPPOSITE SIDE

317769A

Part No. 318140

43" LAWN TRACTOR MODEL B3560-740

key#	part#	description	qty.
1	315914	FRAME,LF DRILLED P920/F4360	1
2	310005	FOOTPAD,LH	1
3	310006	FOOTPAD,RH	1
4	309235	FASTENER, RATCHET	12
5	313047	BRKT,GRILL LH	1
6	313048	BRKT,GRILL RH	1
7	56361	BRACKET, FRONT AXLE	1
8	56030	SCREW, 5/16-18X.75WDFLLK	5
9	55273	NUT, 5/16-18 HXWDFLLK	5
10	300440	GUIDE, BELT, RIDER	1
11	1498	NUT, 5/16-18 REGHEXCTRLK	1
12	308207	BOLT, .625X2.18 HSH 1/2-13	1
13	309008	NUT, 1/2-13 HEXJAM CTRLK	1
14	122207	SCREW, 3/8-16X3.00 HHC	2
15	2483	WASHER,.39IDX1.25DX.07 BELLVIL	2
16	1499	NUT, 3/8-16 REGHEXCTRLK	2
17	120229	SCREW, 5/16-18X .88 HHC	2
18	1498	NUT, 5/16-18 REGHEXCTRLK	2
19	300635	GUIDE,BELT SHORT 15" WHEEL	1
20	124824	NUT, 5/16-18 HEXJAM	1
21	271190	NUT, 3/8-16 HEXKEPS	1
22	310638	CONSOLE,GENERIC H14-15 SOF	1
23	46763	RIVET, POP	1
24	35497	SCREW, 5/16-18X .50 WAHTAP	1
25	995346	SCREW, 1/4-20X .50 WAHTAP	12
26	304880	DASHBOARD	1
27	995346	SCREW, 1/4-20X .50 WAHTAP	2
28	57159	LATCH, .94WDX.047 ASSY HOOD	2
29	8482	BOLT, .375X .156 HSH 5/16-18	2
30	120394	WASHER, FLAT .406X .81X.065	2
31	120393	WASHER, FLAT .344X .69X.065	2
32	1498	NUT, 5/16-18 REGHEXCTRLK	2
33	53446	PIN, 5/16-18 HOOD LATCH	2
34	138538	WASHER, REGINTLK.320X.61X.03	2
35	45174	NUT, 5/16-18 HEXWDFLLK WHIZ	2
36	312306	BAFFLE CONSOLE SOUND EXPORT	1
37	300314	SCREW, 1/4-20X .88WAHTAP	2
38	120392	WASHER, FLAT .281X .63X.065	2
39	1502	NUT, 1/4-20 REGHEXCTRLK	2
40	316527	HOOD, LF H-20 DYNA-PRO	1
41	47453	EDGING,WIDE BLK	27.5"
42	314476	GRILLE DYNA-PRO G-17	1
43	274672	SCREW, 1/4-20X .63 WAHHC	4
44	120393	WASHER, FLAT .344X .69X.065	4
45	1502	NUT, 1/4-20 REGHEXCTRLK	4
46	302333	LENS, SMOKED W/TAB NO LOGO	1
47	314948	FOIL,LENS DYNA-PRO REFLECTOR	1
48	57796	SCREW, #6 X .50 PLASTITE	4
49	36149	BOLT, .375X .500 HSH 5/16-18	2
50	1498	NUT, 5/16-18 REGHEXCTRLK	2
51	310748	LANYARD,HOOD 15.77LG H15	1
52	48900	SCREW, 1/4-20X1.00 WAHHC	1
53	120392	WASHER, FLAT .281X .63X.065	1
54	1502	NUT, 1/4-20 REGHEXCTRLK	2
55	180018	SCREW, 1/4-20X.62 HHC	1
56	120380	WASHER, REGSPLTLK .263X.49X.07	1
57	305857	PLATE, SEAT F-5 SF & LF	1
58	812810	BRACKET, F-5 SEAT SUPPORT	2
59	20507	BOLT, .437X .156 HSH 5/16-18	2
60	1498	NUT, 5/16-18 REGHEXCTRLK	2
61	120228	SCREW, 5/16-18X .63 HHC	4
62	1498	NUT, 5/16-18 REGHEXCTRLK	4
63	57153	SPRING,SEAT 2.63LG,1.49OD BLK	2
64	1341	CLAMP,SPRING	2
65	44811	SCREW, 1/4-20X .75 HXWATAP	2
66	56907	COVER,SEAT SPRING	2
67	312405	FENDER F-5 SUS LF FDR SHIFT	1
68	995346	SCREW, 1/4-20X .50 WAHTAP	4
69	122017	SCREW, 5/16-18X1.00 HHC	2
70	446363	WASHER, FLAT .375X .88X.082	4
71	1498	NUT, 5/16-18 REGHEXCTRLK	2
72	55021	TRIM,STRIP,BLACK	75"
73	311209	COVER PLASTIC	1
74	313213	BRACKET,COVER	1
75	311331	SCREW, 1/4-15X.44/.53 HILOHHWA	2
76	1341	CLAMP,SPRING	2
77	311331	SCREW, 1/4-15X.44/.53 HILOHHWA	2
78	305386	FLAP, LONG	1
79	305354	FLAP, SHORT	1
80	57034	SCREW, 10-24 X .63 TRHMA	10
81	1501	WASHER, FLAT	10
82	271166	NUT, #10-24 HEXKEPS	10
83	318112	OPERATOR'S MANUAL (NOT ILLUSTRATED)	1
84	318140	PART'S MANUAL (NOT ILLUSTRATED)	1

◇ Indicates STANDARD HARDWARE ITEMS.

43" LAWN TRACTOR MODEL B3560-740

MOWER SUSPENSION ASSEMBLY

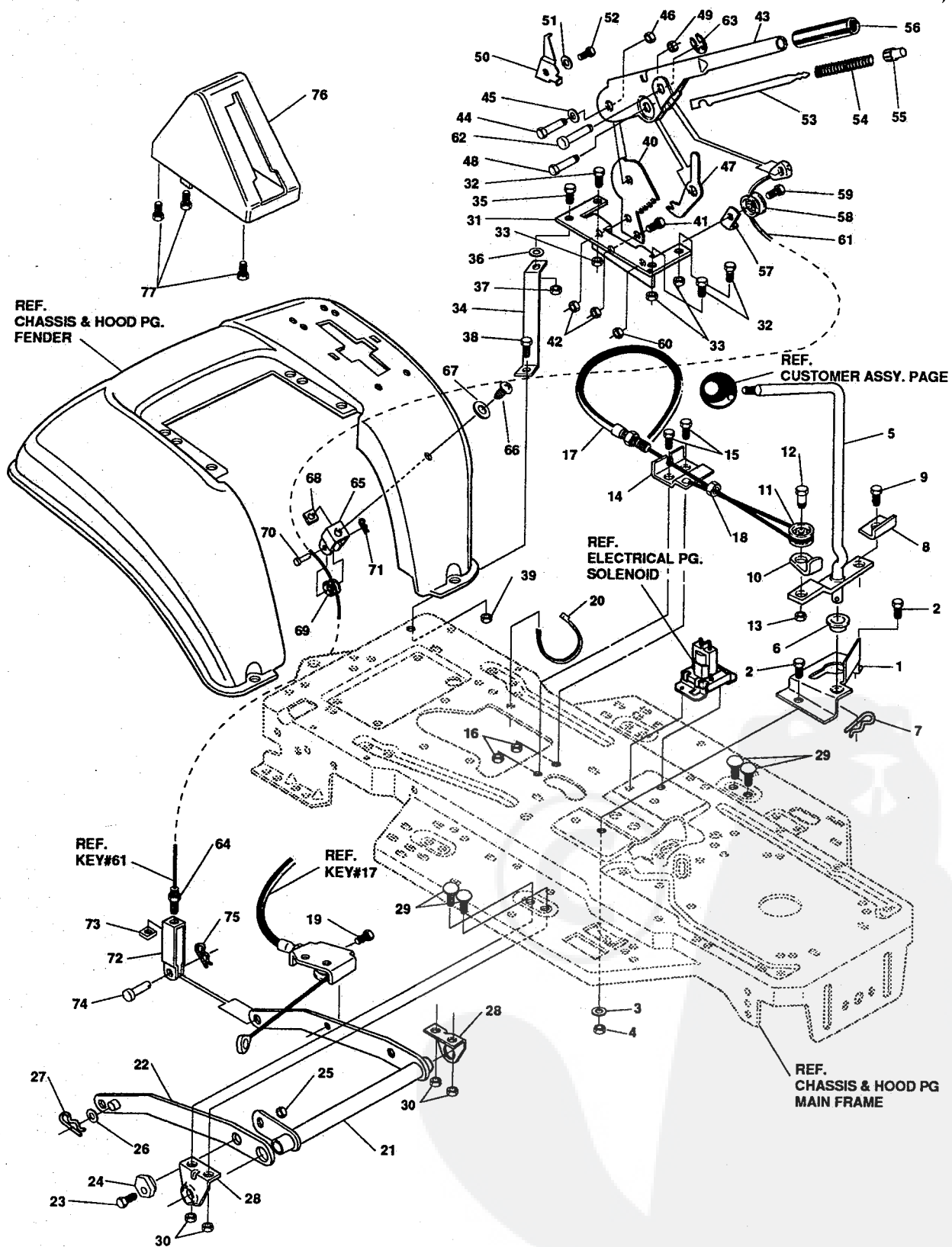

NOTE: ALWAYS USE ORIGINAL EQUIPMENT PARTS. Use of service/replacement parts other than original equipment parts may void your warranty.

ALL UNNUMBERED
ITEMS ARE INTERCHANGABLE
WITH OPPOSITE SIDE

315029B

43" LAWN TRACTOR MODEL B3560-740

key#	part#	description	qty.
1	9402	BRACKET,CLUT-ENGAGELEVER	1
2	180079	◇ SCREW, 5/16-18X1.00 HHC	2
3	120393	WASHER, FLAT .344X.69X.065	2
4	1498	◇ NUT, 5/16-18 REGHEXCTRLK	2
5	304791	ASSY,CLUTCH LEVER	1
6	50148	BEARING,FL. .503IDX.628OD	1
7	8260	PIN, HAIR .091 DIA X1.66LG	1
8	315347	BRACKET,SWITCH ENGAGE	1
9	35498	◇ SCREW, 5/16-18X .75 WAHHTAP	1
10	1288	BRKT,CABLE RETAINER	1
11	39298	PULLEY, .906X.305 NYLON	1
12	58336	BOLT, .375X .375 HSH 1/4-20	1
13	1502	◇ NUT, 1/4-20 REGHEXCTRLK	1
14	9397	BRKT, FRAME CABLE	1
15	180020	◇ SCREW, 1/4-20X .75 HHC	2
16	1502	◇ NUT, 1/4-20 REGHEXCTRLK	2
17	301503	ASSY,CABLE, BLADE ENGAGE	1
18	120613	◇ NUT, 1/4-28 HJAM	1
19	35498	◇ SCREW, 5/16-18X .75 WAHHTAP	1
20	57444	TIE, CABLE BLACK NYLON	1
21	9569	ASSY,REAR LIFT	1
22	9186	ASSY.LINK,RIGHT SIDE	1
23	180079	◇ SCREW, 5/16-18X1.00 HHC	1
24	58247	ADJUSTING NUT	1
25	1498	◇ NUT, 5/16-18 REGHEXCTRLK	1
26	120396	WASHER, FLAT .531X1.06X.095	2
27	8260	PIN, HAIR .091 DIA X1.66LG	2
28	9117	BRKT,REAR,HANG,SUSP.	2
29	126211	BOLT, 5/16-18X .63 CARR	4
30	1498	◇ NUT, 5/16-18 REGHEXCTRLK	4
31	58333	BRACKET,HGT/ADJUST SUPPORT	1
32	180077	◇ SCREW, 5/16-18X .75 HHC	3
33	1498	◇ NUT, 5/16-18 REGHEXCTRLK	3
34	304766	BRACE, FENDER F-5 SUS	1
35	180079	◇ SCREW, 5/16-18X1.00 HHC	1
36	45602	WASHER, FLAT .333X .87X.119	1
37	1498	◇ NUT, 5/16-18 REGHEXCTRLK	1
38	180079	◇ SCREW, 5/16-18X1.00 HHC	1
39	1498	◇ NUT, 5/16-18 REGHEXCTRLK	1
40	301238	QUADRANT,HEIGHT ADJUST	1
41	180077	◇ SCREW, 5/16-18X .75 HHC	2
42	1498	◇ NUT, 5/16-18 REGHEXCTRLK	2
43	9788	HANDLE,LIFT SHORT BLK	1
44	300171	BOLT, .500X .270 HSH 5/16-18	1
45	996418	WASHER, FLAT .506X .75X.024	1
46	44108	◇ NUT, 5/16-18 HWDFLCTRLK	1
47	301239	PAWL, HEIGHT ADJUST	1
48	300171	BOLT, .500X .270 HSH 5/16-18	1
49	44108	◇ NUT, 5/16-18 HWDFLCTRLK	1
50	9435	POINTER Z-PL	1
51	138479	WASHER, EXLK .195X.41X.03	1
52	35287	◇ SCREW, #8-32X .38 HHWAT	1
53	303027	ROD,ACTUATOR-SHORT	1
54	58326	SPRING, HEIGHT ADJUST	1
55	58325	KNOB, HGT ADJ PUSH BUTTON	1
56	58329	GRIP, .750 OD W/ HOLE	1
57	9149	BRKT, CABLE RETAIN	1
58	39298	PULLEY, .906X.305 NYLON	1
59	58336	BOLT, .375X .375 HSH 1/4-20	1
60	1502	◇ NUT, 1/4-20 REGHEXCTRLK	1
61	314177	CABLE, LIFT 21.70 F-5 20X8-8	1
62	300310	PIN,CLEVIS .310DIA+.475LG	1
63	300311	RING, RET E .31X.24	1
64	120375	◇ NUT, 1/4-20 REGHEX	1
65	9239	CLEVIS	1
66	439455	◇ SCREW, 5/16-18X .56PHPNMA BKPH	1
67	301551	WASHER,.344IDX1.50DX.09 CU BPH	1
68	120373	◇ NUT, 5/16-18 SQ	1
69	39298	PULLEY, .906X.305 NYLON	1
70	300317	PIN, CLEVIS .38 DIA X1.00 LG	1
71	8260	PIN, HAIR .091 DIA X1.66LG	1
72	9405	CLEVIS, LIFT CABLE	1
73	120372	◇ NUT, 1/4-20 REGSQ	1
74	39522	PIN CLEVIS .312 X .812	1
75	121222	PIN, COTTER .090/.086X.75LG	1
76	300335	LIFT COVER-39" F5	1
77	300340	◇ SCREW, #10 X .75 HHPLAST	3

43" LAWN TRACTOR MODEL B3560-740

STEERING ASSEMBLY

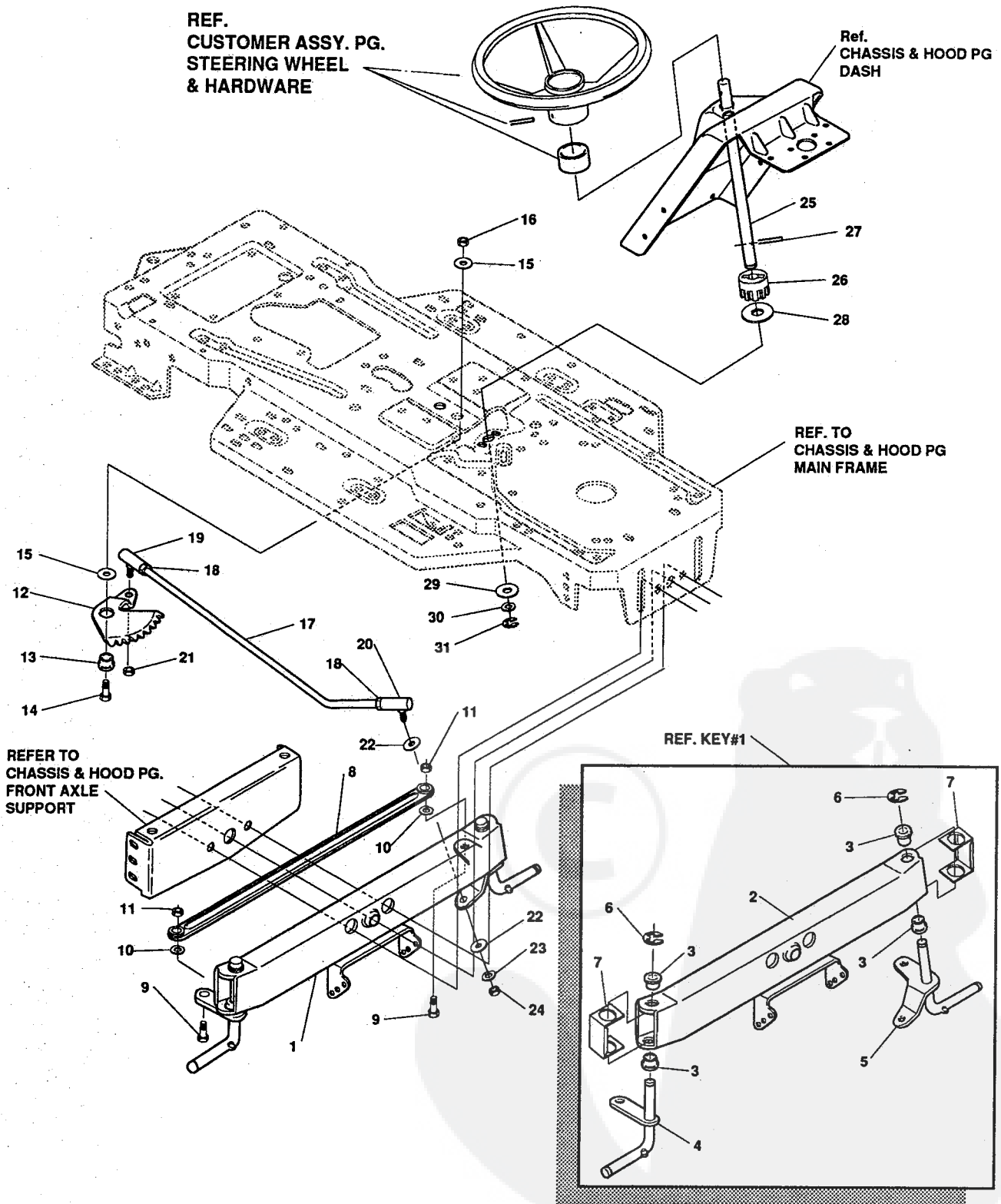

ALL UNNUMBERED
ITEMS ARE INTERCHANGABLE
WITH OPPOSITE SIDE

NOTE: ALWAYS USE ORIGINAL EQUIPMENT PARTS. Use of service/replacement parts other than original equipment parts may void your warranty.

317129A

43" LAWN TRACTOR MODEL B3560-740

key#	part#	description	qty.
1	*	AXLE,FRONT ASSY SUS LF	1
2	300272	ASSY FRONT AXLE SUSPENDED	1
3	52407	SPINDLE BEARING	4
4	9180	ASSY,SPINDLE,RH	1
5	314088	ASSY,SPINDLE,LH	1
6	36625	RING, RETEX .57X.05TRU5133-75	2
7	53373	AXLE COVER	2
8	304590	TIE ROD ASSY 19.81LG	1
9	◇180128	SCREW, 3/8-16X1.75 HHC	2
10	120382	WASHER, REGSPTLK.393X.68X.10	2
11	◇1499	NUT, 3/8-16 REGHXCTRLK	2
12	58289	SECTOR, STEERING LF	1
13	52406	BRNG,FL ECC.510IDX .998ODX .56	1
14	180177	SCREW, 1/2-13X1.50 HHC	1
15	22265	WASHER, FLAT .515X1.38X.119PL	2
16	◇1500	NUT, 1/2-13 REGHCTRLK	1
17	58291	STEERING LINK	1
18	◇124925	NUT, 3/8-24 REGHEXJAM	2
19	57158	BALL JOINT 3/8 THD SHORT STUD	1
20	21275	BALL JOINT 3/8 TH'D LONG STUD	1
21	◇46692	NUT, 3/8-24 WDFLHLK WHIZ	1
22	◇120396	WASHER, FLAT .531X1.06X.095	2
23	◇120382	WASHER, REGSPTLK.393X.68X.10	1
24	◇120369	NUT, 3/8-24 REGHEX	1
25	58243	SHAFT, STEERING LF	1
26	58244	PINION, STEERING LF	1
27	58274	PIN,DOWEL .2500 OD+1.75LG	1
28	301410	BRNG, FL .752IDX1.061ODX .24	1
29	301398	WASHER, FORMED1.135X1.53X.12	1
30	◇ 21682	WASHER, FLAT .765X1.25X.042	1
31	36625	RING, RETEX .57X.05TRU5133-75	1

◇ Indicates STANDARD HARDWARE ITEMS.

* Order Individual Parts

43" LAWN TRACTOR MODEL B3560-740

MOTION DRIVE ASSEMBLY

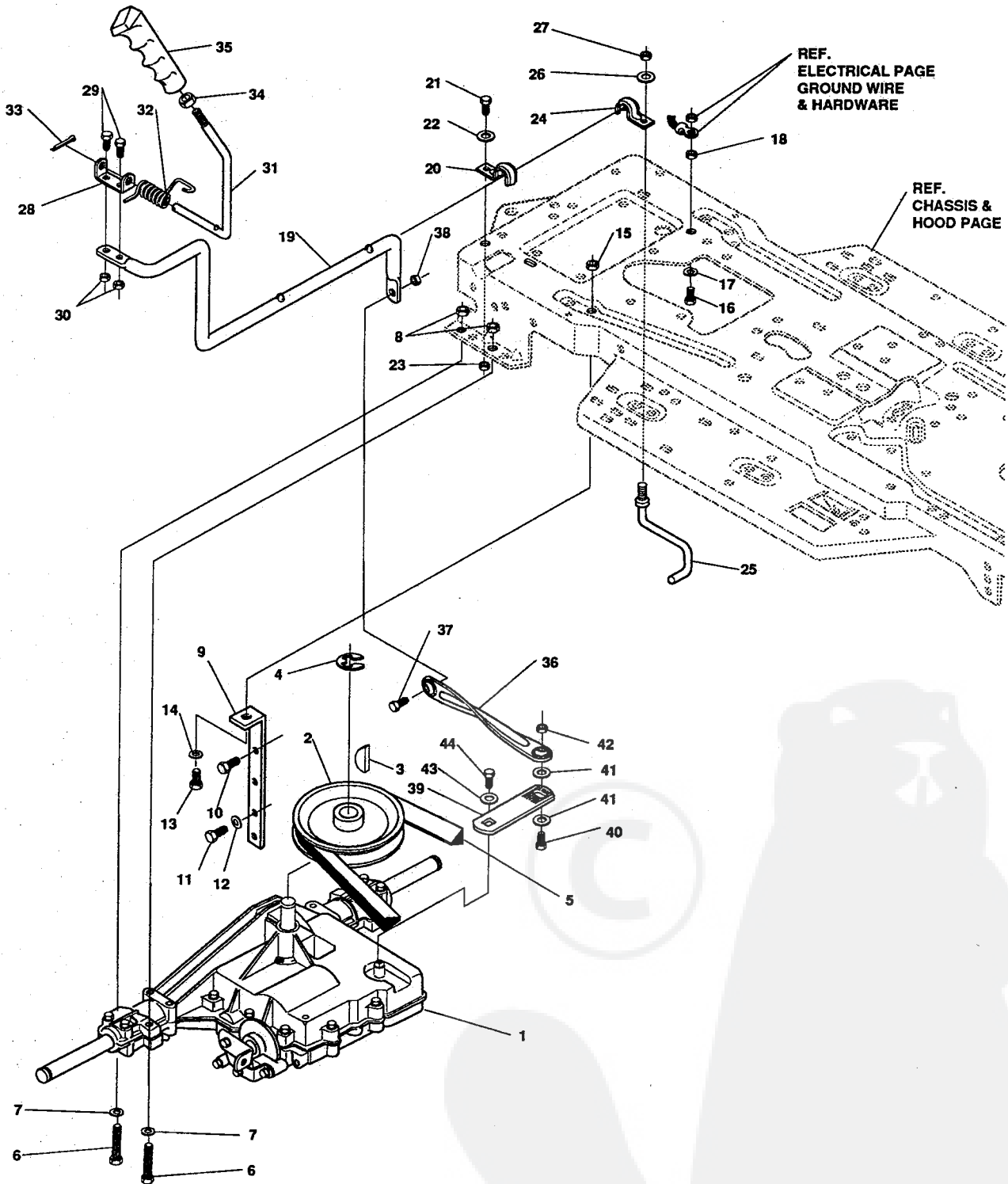

NOTE: ALWAYS USE ORIGINAL EQUIPMENT PARTS. Use of service/replacement parts other than original equipment parts may void your warranty.

ALL UNNUMBERED ITEMS ARE INTERCHANGABLE WITH OPPOSITE SIDE

317122A

43" LAWN TRACTOR MODEL B3560-740

key#	part#	description	qty.
1	TRANSAXLE	FOOTE 4360-6SPHD(CONTACT NEAREST DEALER)	1
2	302745	PULLEY,V 4L 6.60 OD	1
3	3021	KEY, WDRF 606 .750X.187X.312	1
4	22053	RING, RETEX .58X.04TRU5100-62	1
5	314120	BELT, V 4L 87.25 4WS LF	1
6	◇180112	SCREW, 5/16-18X2.75 HHC GR5	4
7	◇120393	WASHER, FLAT .344X .69X.065	4
8	◇1498	NUT, 5/16-18 REGHEXCTRLK	4
9	12632	BRACKET,STABILIZER	1
10	◇50947	SCREW, 3/8-16X1.25 WAHHTAP	1
11	◇35498	SCREW, 5/16-18X .75 WAHHTAP	1
12	◇120638	WASHER, HVSPTLK .328X.60X.09	1
13	◇122017	SCREW, 5/16-18X1.00 HHC GR2	1
14	◇120393	WASHER, FLAT .344X .69X.065	1
15	◇1498	NUT, 5/16-18 REGHEXCTRLK	1
16	◇120228	SCREW, 5/16-18X .63 HHC GR2	1
17	138538	WASHER, REGINTLK.320X.61X.03	1
18	◇1498	NUT, 5/16-18 REGHEXCTRLK	1
19	310029	LEVER,SHIFT,LWR 4360 LF	1
20	310348	CLIP-SHIFT LEVER .62 ROD	1
21	◇180077	SCREW, 5/16-18X .75 HHC	1
22	996416	WASHER, FLAT .391X1.00X.125	1
23	◇1498	NUT, 5/16-18 REGHEXCTRLK	1
24	310348	CLIP-SHIFT LEVER .62 ROD	1
25	57259	GUIDE, BELT 5/16-18THD	1
26	◇996416	WASHER, FLAT .391X1.00X.125	1
27	◇1498	NUT, 5/16-18 REGHEXCTRLK	1
28	310356	BRACKET,PIVOT SHIFT LEVER	1
29	◇180018	SCREW, 1/4-20X .62 HHC	2
30	◇1502	NUT, 1/4-20 REGHEXCTRLK	2
31	309635	LEVER, SHIFT UPPER SF 1/2-13TH	1
32	310265	SPRING, TORS. .56X.95X.095	1
33	137185	PIN, COTTER .125 DIA X1.00LG	1
34	◇120238	NUT, 1/2-13 HEXJAM	1
35	306690	HANDLE 1/2-13 MOLDED	1
36	314971	LINK TIE ROD SHIFTER 7.746C/L	1
37	◇180124	SCREW, 3/8-16X1.25 HHC	1
38	◇1499	NUT, 3/8-16 REGHXCTRLK	1
39	309637	BRACKET,SHIFT 5SP SF FEN HT	1
40	◇180124	SCREW, 3/8-16X1.25 HHC GR5	1
41	◇120394	WASHER, FLAT .406X .81X.065	2
42	◇1499	NUT, 3/8-16 REGHXCTRLK	1
43	◇57157	WASHER,.750X.250 SP-TRANSAXLE	1
44	◇56255	SCREW, 1/4-28X .75 NYLHHCGR8	1

◇ Indicates STANDARD HARDWARE ITEMS.

43" LAWN TRACTOR MODEL B3560-740

MOTION DRIVE ASSEMBLY

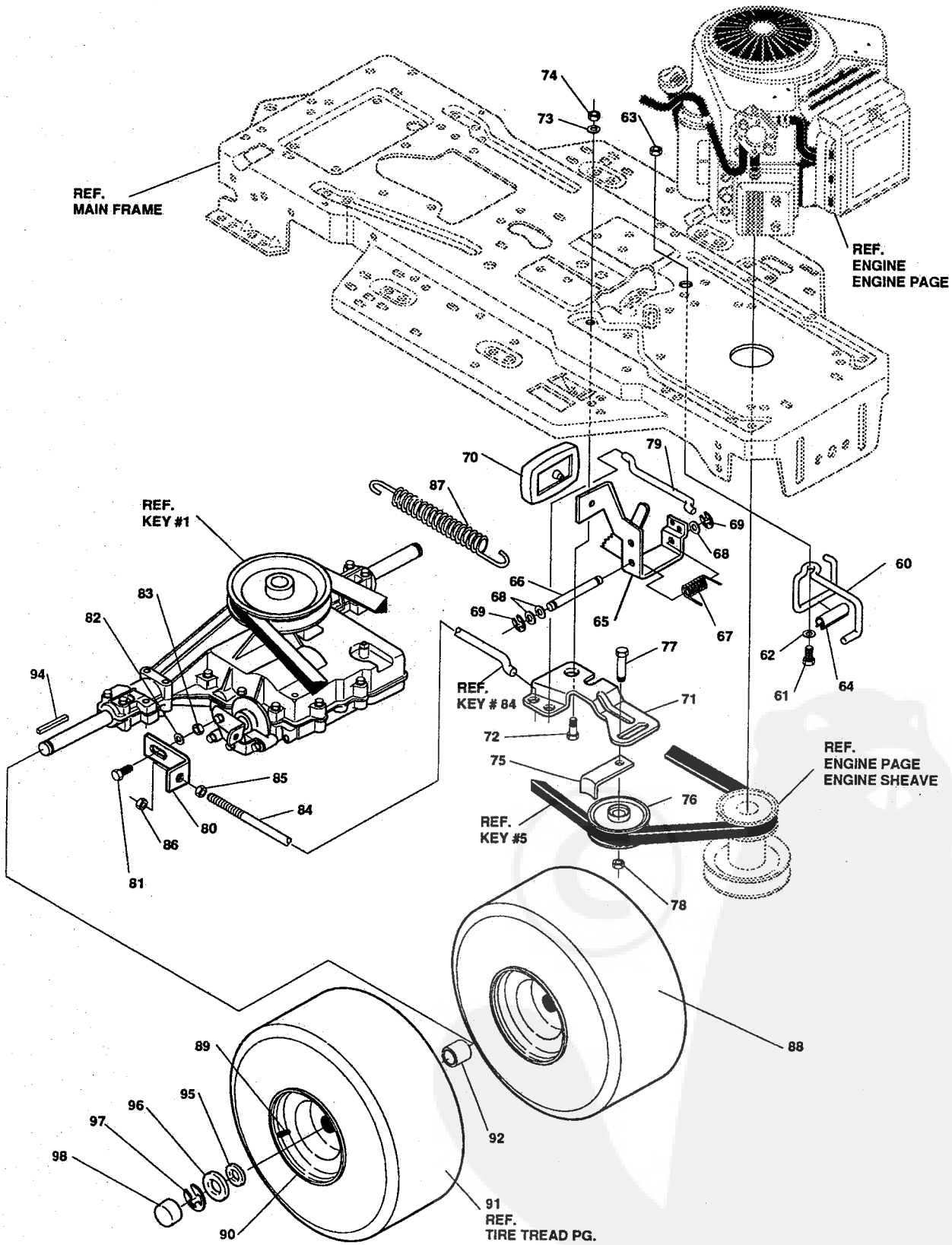

NOTE: ALWAYS USE ORIGINAL EQUIPMENT PARTS.
Use of service/replacement parts other than original equipment parts may void your warranty.

**ALL UNNUMBERED
ITEMS ARE INTERCHANGABLE
WITH OPPOSITE SIDE**

317122A

43" LAWN TRACTOR MODEL B3560-740

key#	part#	description	qty.
60	58356	GUIDE-BELT/DRAGLINK	1
61	◇180079	SCREW, 5/16-18X1.00 HHC GR5	1
62	◇45602	WASHER, FLAT .333X .87X.119	1
63	◇1498	NUT, 5/16-18 REGHEXCTRLK	1
64	303278	PLASTIC EXTRUSION-BELT GUIDE	1
65	300308	PEDAL ASSY,BRAKE/CLUTCH LF	1
66	57196	ROD,PIVOT .50 OD+4.44LG	1
67	57847	SPRING, BRAKE PEDAL	1
68	2968	WASHER, FLAT .504X .75X.059	3
69	20864	RING, RET E .39X.04TRU5133-50	2
70	48160	PAD, CLUTCH BRAKE W/PRINTING	1
71	300154	ARM,IDLER TRACTION DR. LF	1
72	300793	BOLT, .625X .135 HSH 5/16-18	1
73	◇45602	WASHER, FLAT .333X .87X.119	1
74	◇1498	NUT, 5/16-18 REGHEXCTRLK	1
75	39659	RETAINER,BELT	1
76	35374	PULLEY, IDLER V4L 3.06X .62	1
77	45892	BOLT, 3/8-16X1.50 CARR GR2	1
78	◇1499	NUT, 3/8-16 REGHXCTRLK	1
79	57204	ROD, CLUTCH	1
80	57217	BRACKET, BRAKE ROD	1
81	20507	BOLT, .437X .156 HSH 5/16-18	1
82	45602	WASHER, FLAT .333X .87X.119	1
83	◇1498	NUT, 5/16-18 REGHEXCTRLK	1
84	313659	ROD, BRAKE P920 4WS LF 23.50	1
85	◇271184	NUT, 5/16-18 HEXKEPS	1
86	◇1498	NUT, 5/16-18 REGHEXCTRLK	1
87	56359	SPRING, CLUTCH .113X.750X8.75	1
88	*	TIRE&RIM,PU20X8.00-8TURFWHI134	2
89	24167	VALVE STEM	1
90	57165	WHEEL 20X8.00 WHITE .75 DIAHUB	1
91	314584	TIRE, PU 20X8.00-8RDSHTURFTRAC	1
92	57479	SPACER, .75 X 1.25 X 1.32	2
93	301565	SPACER,SLVE .75IDX1.25OD X.5TK	2
94	39628	KEY, SQUARE .187SQX2.50LG	2
95	◇642	WASHER, FLAT .755X1.31X.075	4
96	◇42815	WASHER, FLAT .755X1.53X.07	2
97	36625	RING, RETEX .57X.05TRU5133-75	2
98	40394	CAP, 1.500ID X 7/8LG HUB	2

◇ Indicates STANDARD HARDWARE ITEMS.

* Order Individual Parts

43" LAWN TRACTOR MODEL B3560-740

ENGINE & CONTROL ASSEMBLY

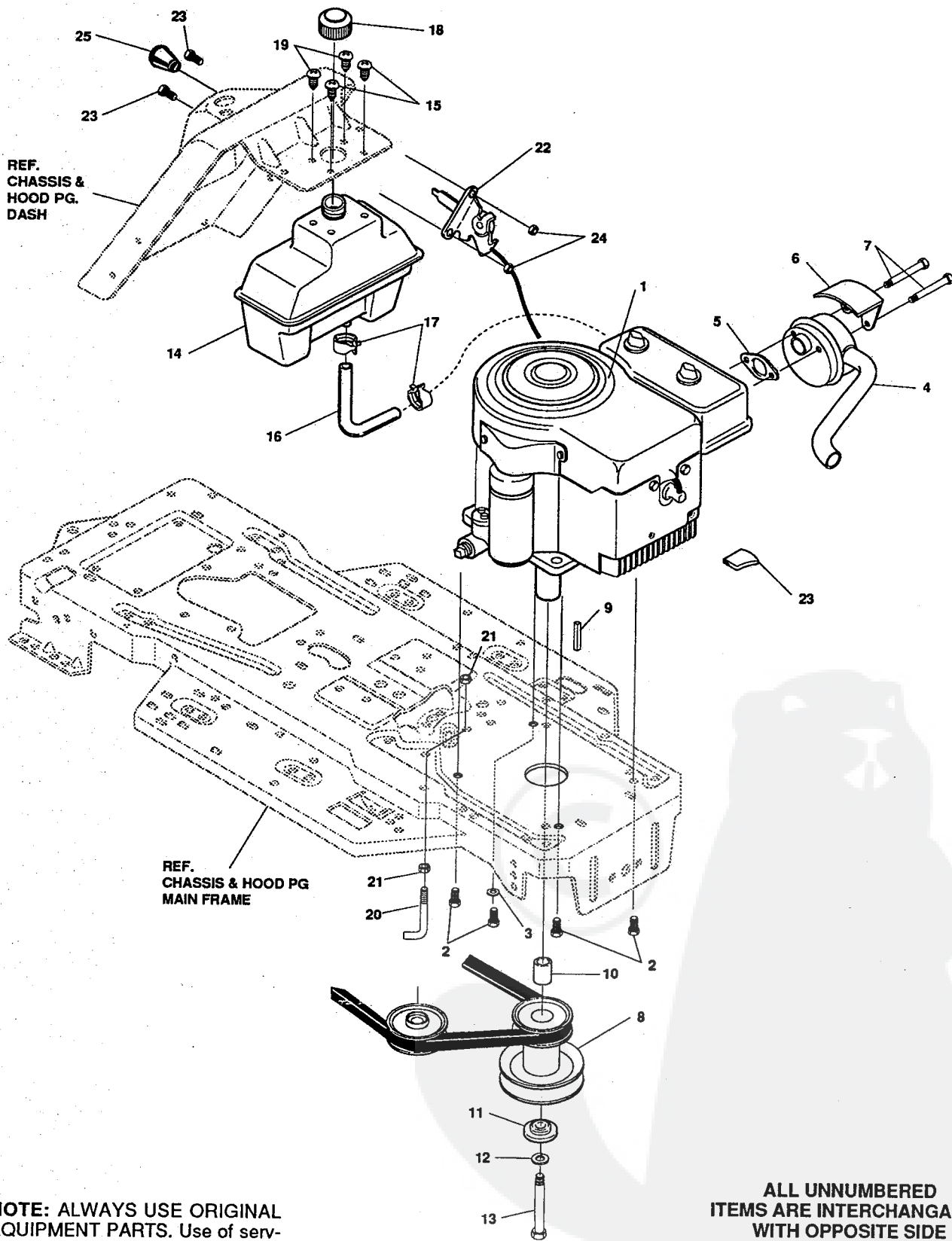

317768A

43" LAWN TRACTOR MODEL B3560-740

key#	part#	description	qty.
1	ENGINE	12 HP B&S I/C (SEE ENGINE MANUAL)	1
2	◇50947	SCREW, 3/8-16X1.25 WAHHTAP	4
3	138489	WASHER, EXLK .384X.69X.04	1
4	305367	MUFFLER-LO TONE NELSON EXPORT	1
5	46708	GASKET, MUFFLER	1
6	54767	SHIELD, HEAT, FOR ROUND MUFFLER	1
7	◇173063	SCREW, 5/16-18X3.50 HHC	2
8	316802	PULLEY ASSY, 4.75OFFS 5.5DIA	1
9	57791	KEY, SQUARE .250SQX5.00	1
10	304246	SPACER, 1.01X1.484 ENGIN PULLEY	1
11	56431	WASHER, .980IDX1.38ODX.437PILOT	1
12	120383	WASHER, REGSPTLK.459X.78X.12	1
13	◇428644	SCREW, 7/16-20X5.00 HHC	1
14	314989	FUEL TANK	1
15	49050	SCREW, 1/4-10X.75	4
16	47452	GAS LINE	13"
17	48672	CLAMP, FUEL LINE	2
18	46704	GAS CAP 1-1/2-7 THD	1
19	302967	ENGINE SPEED REDUCER	1
20	301713	UPSTOP ROD	1
21	◇45171	NUT 3/8-16 HWD FL WHIZ-LOCK	2
22	56534	CONTROL THROTTLE	1
23	35291	SCREW, 10-24X.50 SLHHMA	2
24	271166	NUT, #10-24 HEXKEPS	2
25	50607	KNOB, ROUND THROTTLE	1

◇ Indicates STANDARD HARDWARE ITEMS.

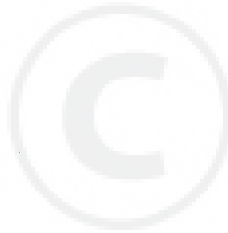

43" LAWN TRACTOR MODEL B3560-740

PRE-PAINTED DECK ASSEMBLY

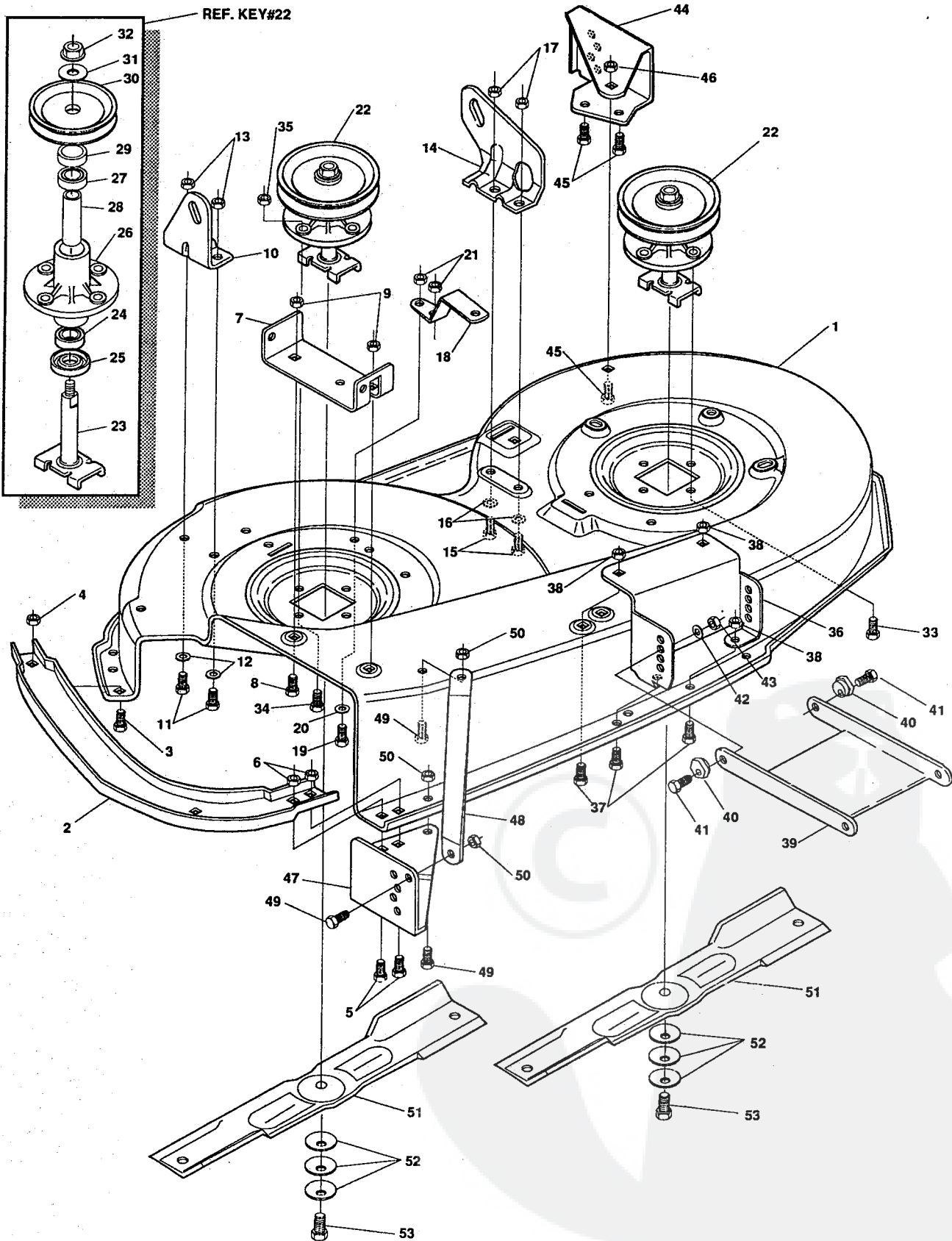

NOTE: ALWAYS USE ORIGINAL EQUIPMENT PARTS. Use of service/replacement parts other than original equipment parts may void your warranty.

ALL UNNUMBERED ITEMS ARE INTERCHANGABLE WITH OPPOSITE SIDE

315656D

43" LAWN TRACTOR MODEL B3560-740

key#	part#	description	qty.
1	316835	MOWER DECKS, RIDER 43"	1
2	304102	TOE GUARD	1
3	◇180075	SCREW, 5/16-18X .63 HHC	1
4	◇1498	NUT, 5/16-18 REGHEXCTRLK	1
5	◇122007	SCREW, 5/16-18X .75 HHC	2
6	◇1498	NUT, 5/16-18 REGHEXCTRLK	2
7	302364	BRACKET CHUTE MOUNT	1
8	◇180075	SCREW, 5/16-18X .63 HHC	2
9	◇1498	NUT, 5/16-18 REGHEXCTRLK	2
10	58250	LIFT BRACKET, REAR,RH	1
11	◇180077	SCREW, 5/16-18X .75 HHC	2
12	◇120393	WASHER, FLAT .344X .69X.065	2
13	◇1498	NUT, 5/16-18 REGHEXCTRLK	2
14	58251	BRACKET,DECK LIFTREAR LH	1
15	◇180077	SCREW, 5/16-18X .75 HHC	2
16	◇120393	WASHER, FLAT .344X .69X.065	2
17	◇1498	NUT, 5/16-18 REGHEXCTRLK	2
18	302363	BRACE IDLER	1
19	◇180077	SCREW, 5/16-18X .75 HHC	2
20	◇120393	WASHER, FLAT .344X .69X.065	2
21	◇44108	NUT, 5/16-18 HWDFLCTRLK	2
22	56424	QUILL ASSY, 36/39/40/43	2
23	56425	SHAFT/SADDLE 36"	1
24	49562	BRNG, BALL	1
25	50616	DUST SHIELD	1
26	55547	QUILL CASTING (1046)	1
27	49562	BRNG, BALL	1
28	50818	SPACER,3.797LGX.669IDX.88OD	1
29	51449	SPACER,.438LGX.932ODX.672ID	1
30	56390	PULLEY,26/36" QUILL	1
31	56365	SPECIAL WASHER	1
32	◇1282	NUT, 7/16-20 WDFLLK	1
33	◇50634	SCREW, 5/16-18X .88 WAHHTAP	7
34	◇300345	SCREW, 5/16-18X1.38 WATAPGR	1
35	◇1498	NUT, 5/16-18 REGHEXCTRLK	1
36	313778	BRACKET FRT.	1
37	◇180075	SCREW, 5/16-18X .63 HHC	4
38	◇1498	NUT, 5/16-18 REGHEXCTRLK	4
39	58305	LINK BRACKET,DECK FR	1
40	58247	ADJUSTING NUT	2
41	◇122017	SCREW, 5/16-18X1.00 HHC	2
42	35214	WASHER, FLAT .328X1.06X.062	2
43	◇1498	NUT, 5/16-18 REGHEXCTRLK	2
44	304426	BRACKET,GAGE WHEEL L.H	1
45	◇180075	SCREW, 5/16-18X .63 HHC	3
46	◇1498	NUT, 5/16-18 REGHEXCTRLK	3
47	313925	BRACKET,GAGE WHEEL R.H.	1
48	314282	BRACKET,STABILIZER	1
49	◇180075	SCREW, 5/16-18X .63 HHC	3
50	◇1498	NUT, 5/16-18 REGHEXCTRLK	3
51	313954	BLADE, 21.70 HIGH-LIFT	2
52	2483	WASHER,.39IDX1.25DX.07 BELLVIL	6
53	◇39573	SCREW, 3/8-24X1.00 NYLHHC	2

◇ STANDARD HARDWARE ITEMS

43" LAWN TRACTOR MODEL B3560-740

FINAL DECK ASSEMBLY

SEE DWG. 315656 FOR PARTS ASSY. OF PAINTED DECK

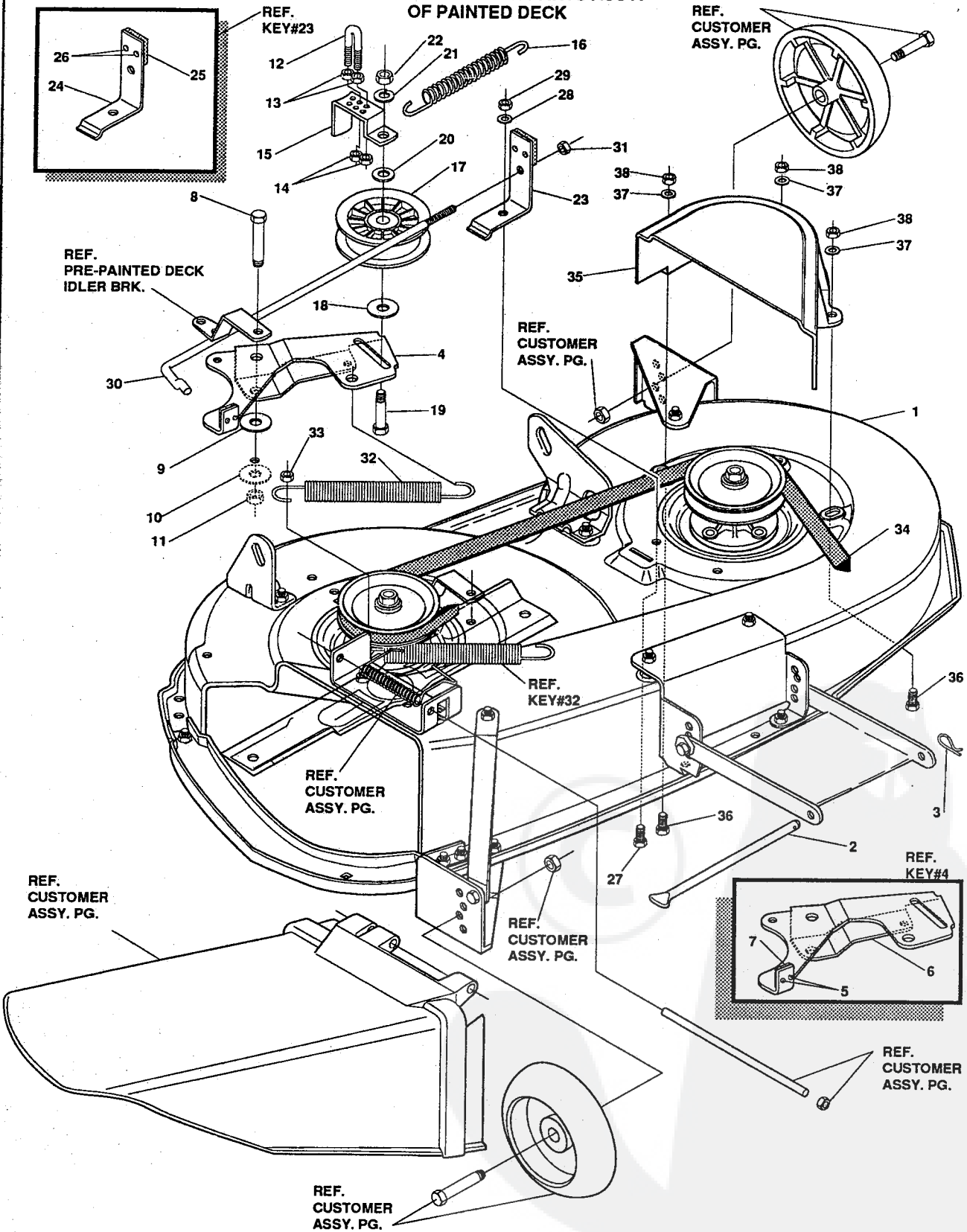

NOTE: ALWAYS USE ORIGINAL EQUIPMENT PARTS.
Use of service/replacement parts other than original equipment parts may void your warranty.

ALL UNNUMBERED ITEMS ARE INTERCHANGABLE WITH OPPOSITE SIDE

315594C

43" LAWN TRACTOR MODEL B3560-740

key#	part#	description	qty.
1	*	DECK ASSEMBLY,43"	1
2	58306	ROD, DECK HITCH Z-PL	1
3	8260	PIN, HAIR .091 DIAX1.66LG	1
4	304414	ASSY.IDLER ARM	1
5	41601	RIVET, OVSET .187DIAX .50LG	2
6	305298	ARM IDLER	1
7	306973	BRAKE PAD - HARD - 232AF	1
8	304420	BOLT, .500X2.15 HXHDCPSH	1
9	996307	WASHER, FLAT .391X1.00X.209	1
10	996416	WASHER, FLAT .391X1.00X.125	1
11	45171	NUT, 3/8-16 HWDFL WHIZ NUT	1
12	317303	U-BOLT	1
13	271166	NUT, #10-24	2
14	997316	NUT, #10-24 REGHXCTRLK	2
15	315873	GUIDE, BELT, IDLER ZINC	1
16	314107	SPRING, TENSION 5.00LG	1
17	310326	PULLEY, IDLER BFF 4.00 WIDE FL	1
18	25210	WASHER, FLAT .392X1.25X.09	1
19	57325	BOLT, 3/8-16X2.00 CARR	1
20	996307	WASHER, FLAT 391X1.00X.125	1
21	120382	WASHER, REGSPTLK.393X.68X.10	1
22	120377	NUT, 3/8-16 REGHX	1
23	304118	BLADE BRAKE ASSY.	1
24	308241	BRAKE ARM	1
25	306973	BRAKE PAD	1
26	135624	RIVET	2
27	120228	◇ SCREW, 5/16-18X .63 HHC	1
28	120393	WASHER, FLAT .344X .69X.065	1
29	1498	NUT, 5/16-18 REGHEXCTRLK	1
30	314079	ROD, BRAKE	1
31	1502	◇ NUT, 1/4-20 REGHEXCTRLK	1
32	35410	SPRING .071 X .62 X 4.37	1
33	1498	NUT, 5/16-18 REGHEXCTRLK	1
34	314108	BELT, V 5L 86.00 KEVLAR	1
35	314106	GUARD, BELT LH PLASTIC	1
36	120228	◇ SCREW, 5/16-18X .63 HHC	3
37	120393	WASHER, FLAT .344X .69X.065	3
38	1498	◇ NUT, 5/16-18 REGHEXCTRLK	3

* Order Individual Parts.

◇ Indicates STANDARD HARDWARE ITEMS

43" LAWN TRACTOR MODEL B3560-740

ELECTRICAL ASSEMBLY

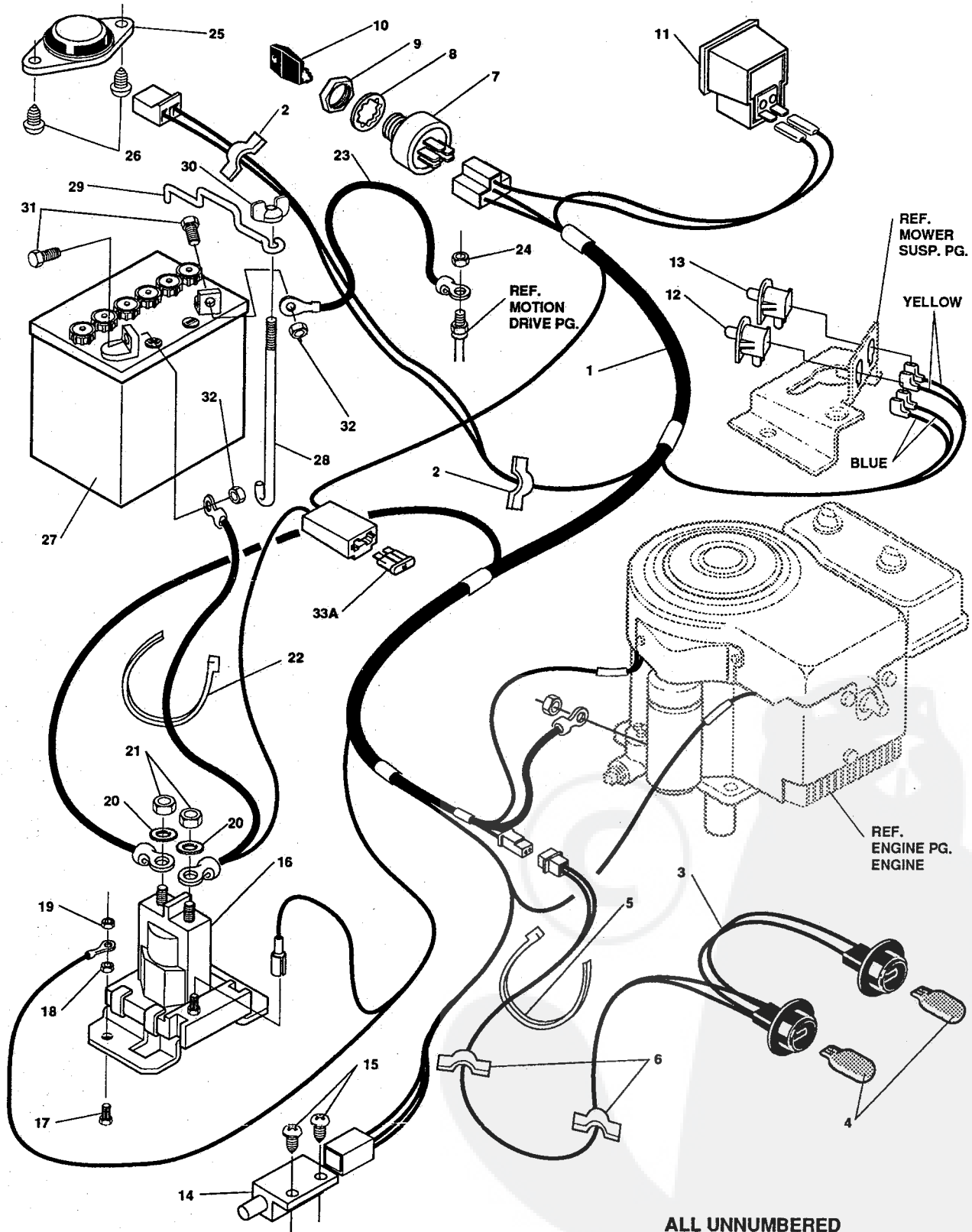

ALL UNNUMBERED
ITEMS ARE INTERCHANGABLE
WITH OPPOSITE SIDE

NOTE: ALWAYS USE ORIGINAL EQUIPMENT PARTS.
Use of service/replacement parts other than original equipment parts may void your warranty.

315441A

43" LAWN TRACTOR MODEL B3560-740

key#	part#	description	qty.
1	300814	WIRE HARNESS 12HP B&S SUS LF	1
2	41482	CLIP, 1.380LG .255ID PRESS WIRE	2
3	303064	ASSY, LIGHT WIRE-1/4 TURN	1
4	52572	BULB, HEADLAMP	2
5	57444	TIE, CABLE BLACK NYLON 5.62L	1
6	41482	CLIP, 1.380LG .255ID PRESS WIRE	2
7	300687	SWITCH, IGNITION & LIGHTS	1
8	138557	WASHER, REGINTLK.640X1.1X.05	1
9	◇48140	NUT, 5/8-32 HXHD IGN SWIT	1
10	300626	KEY, IGNITION SWITCH	1
11	300133	AMMETER, PANEL MOUNT	1
12	300220	SWITCH, SNAPMNT NO .055/.116	1
13	58277	SWITCH, SNAPMNT NC .055/.166	1
14	57211	SWITCH, SCR MNT SP	1
15	◇57220	SCREW, #12 X .50 PHPNHTAP	2
16	53716	SOLENOID, NEW CLUM	1
17	◇187745	SCREW, 1/4-20X .75 HXSEMMA	2
18	◇1502	NUT, 1/4-20 REGHEXCTRLK	2
19	◇271172	NUT, 1/4-20 REGHEXKEPS	1
20	138485	WASHER, EXLK .320X.61X.03	2
21	◇120368	NUT, 5/16-24 REGHEX	2
22	57444	TIE, CABLE BLACK NYLON 5.62	1
23	55511	WIRE, GROUND, 12.5"	1
24	◇271184	NUT, 5/16-18 HEXKEPS	1
25	57547	SWITCH, SEAT	1
26	◇160505	SCREW, 1/4-20X .38PHPNHMA	2
27	302257	BATTERY 12V 7 PLATE/	1
28	57551	ROD, BATTERY	1
29	57552	ROD, BATTERY, TOP	1
30	310067	SMALL PLASTIC WING NUT 1/4-20	1
31	◇120854	SCREW, 1/4-20X .63 HHC	2
32	◇271172	NUT, 1/4-20 REGHEXKEPS	2
33A	** 302031	FUSE, 15 AMP SPADE TYPE	1
33B	** 49211	FUSE, 15 AMP CYLINDRICAL	1

**Cylindrical or Spade type fuse included in wire assembly.
 ◇ Indicates STANDARD HARDWARE ITEMS.

43" LAWN TRACTOR MODEL B3560-740

DECALS

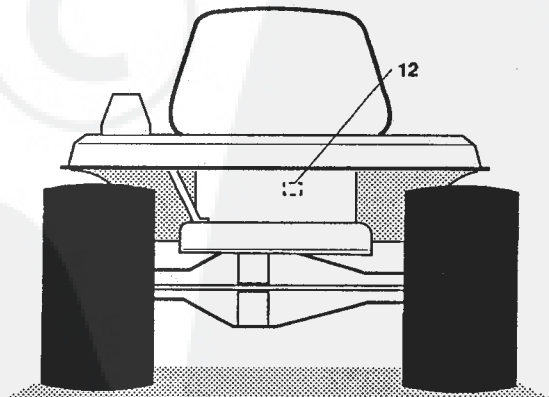
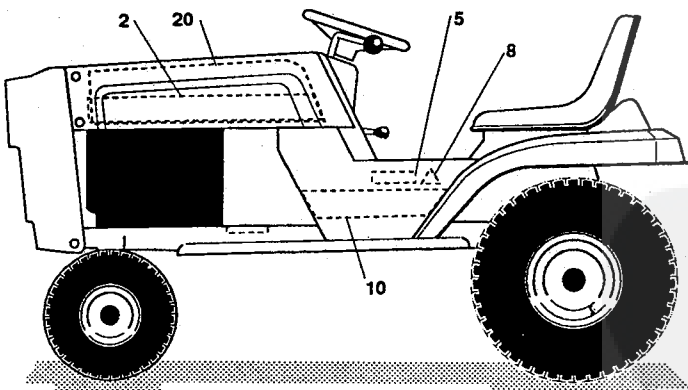
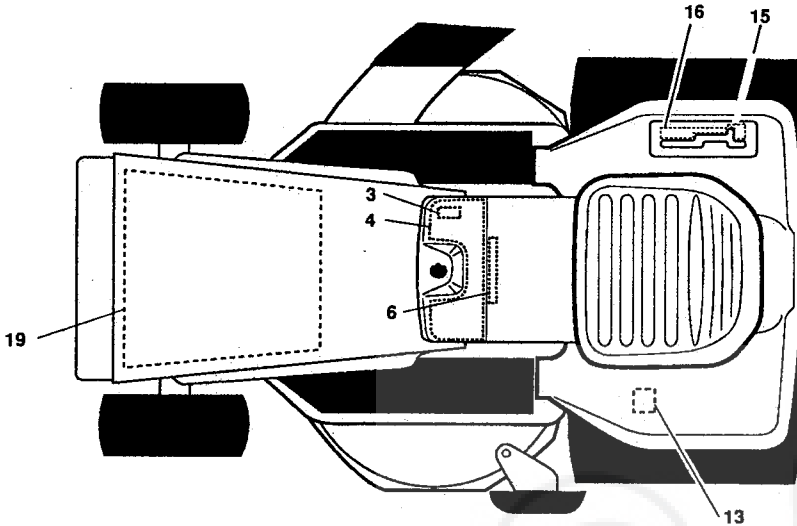
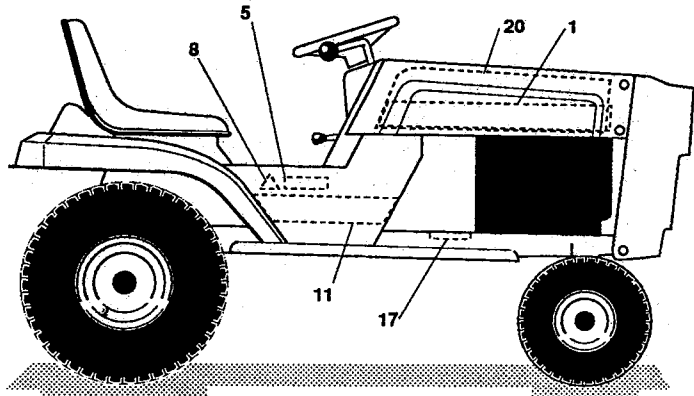
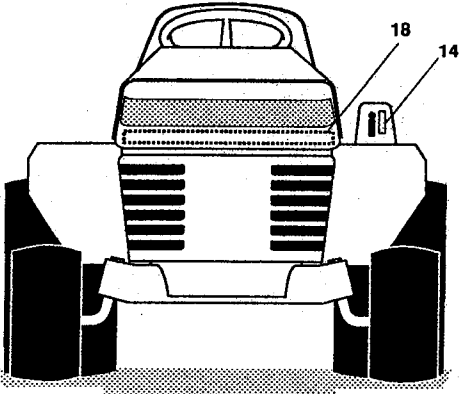

NOTE: ALWAYS USE ORIGINAL EQUIPMENT PARTS.
Use of service/replacement parts other than original equipment parts may void your warranty.

**ALL UNNUMBERED
ITEMS ARE INTERCHANGABLE
WITH OPPOSITE SIDE**

316553A

43" LAWN TRACTOR MODEL B3560-740

key#	part#	description	qty.
1	317645	DECAL,HOOD H6 POWERTRAC LH	1
2	317646	DECAL,HOOD H6 POWERTRAC RH	1
3	68900	DECAL,BLADE ENGAGE EUROPE	1
4	307038	DECAL,DASH,PLAIN BLACK AMM	1
5	68902	DECAL,WARNING,FRENCH/GERMAN	2
6	69524	DECAL,INSTRUCT CONSOLE TOP GER	1
7		REFERENCE ONLY	1
8	305770	DECAL,CAUTION TRIANGLE EUROPE	2
9		REFERENCE ONLY	1
10	317649	DECAL,TRACTOR CONSOLE LH	1
11	317650	DECAL,TRACTOR CONSOLE RH	1
12	318010	DECAL,TUV GS	1
13	68901	DECAL,BLADE HEIGHT ADJ. EUROPE	1
14	301897	DECAL, LIFT DECK BLADE HEIGHT	1
15	311394	DECAL SHIFT REV/NEUTRAL	1
16	311395	DECAL SHIFTER POSITION F4360-6	1
17	68903	DECAL,BRAKE/CLUTCH EUROPE	1
18	317651	DECAL,GRILLE POWERTRAC	1
19	55835	PAD, FOAM HOOD TOP H-6/7	1
20	55836	PAD, FOAM HOOD SIDE H-6/7	2

43" LAWN TRACTOR MODEL B3560-740

CUSTOMER ASSEMBLY

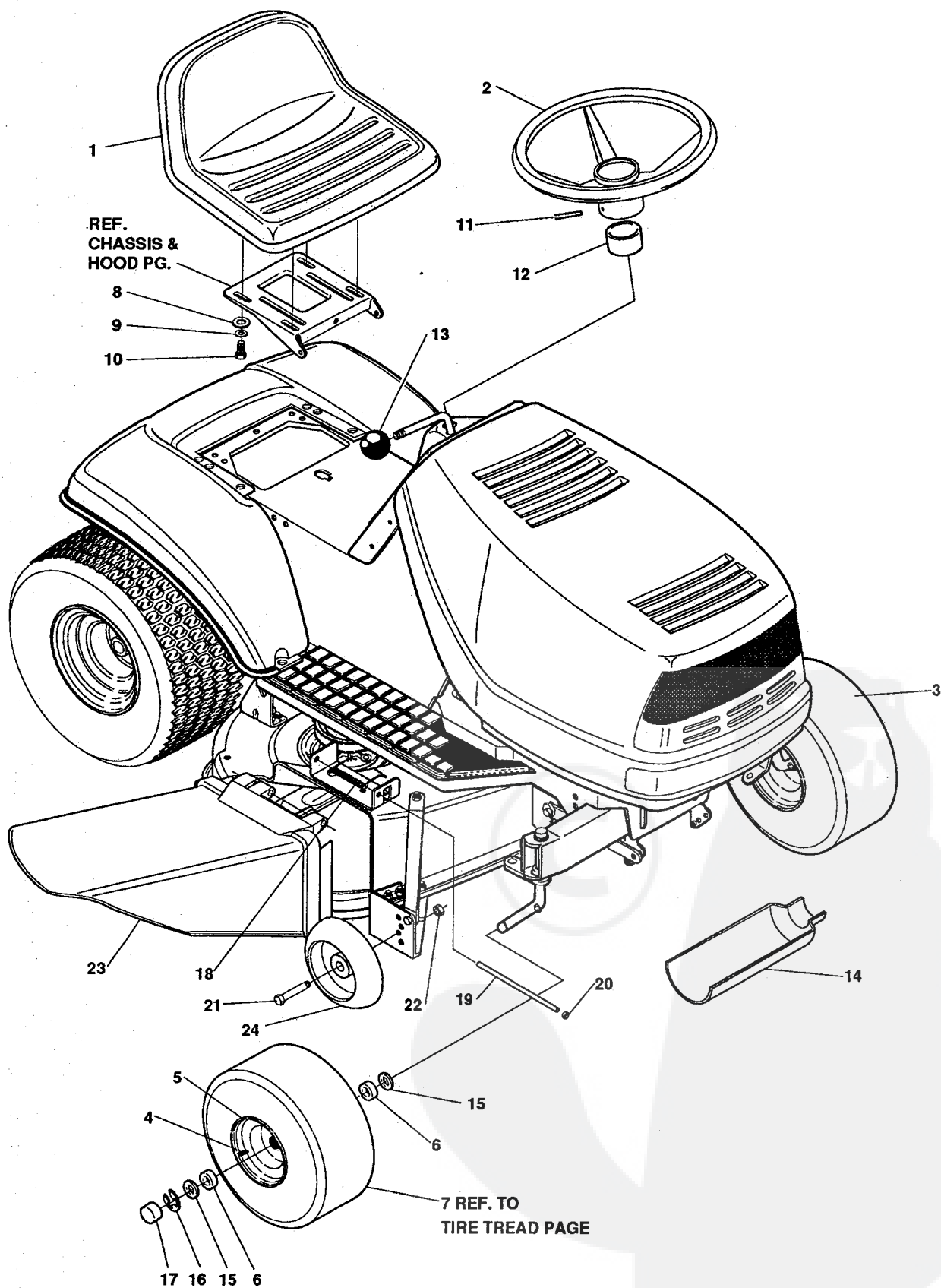

317892A

43" LAWN TRACTOR MODEL B3560-740

CUSTOMER ASSEMBLY VIEW

317355 PARTS BAG ASSY QTY1

key#	part#	description	qty
1	57455	SEAT 550	1
2	301251	STEERING WHEEL 13" STD	1
3	*	TIRE & RIM ASSY. 15X6-6 WHITE	2
4	24167	VALVE STEM	1
5	39829	WHEEL W/BEARINGS	1
6	39979	BEARINGS	2
7		REFER TO TIRE TREAD PAGE	
8	120393	WASHER, FLAT .344X.69X.065	4
9	120638	WASHER, HVSP TLK .328X.60X.09	4
10	122007	SCREW, 5/16-18X.75 HHC	4
11	456378	PIN, SPRING .250DIA X2.00LG	1
12	57212	COVER, STEERING	1
13	55514	KNOB, SHIFT	1
14	54873	OIL TROUGH	1
15	642	WASHER, FLAT .755X1.31X.075	4
16	36625	RING, RETEX	2
17	40394	HUB CAP	2
18	314975	TORSION SPRING	1
19	304424	ROD, PIVOT	1
20	3535	NUT, PUSH	1
21	23763	BOLT, .500X1.390 HHSH 3/8-16	2
22	1499	NUT, 3/8-16 REGHXCTRLK	2
23	304422	CHUTE DEFLECTOR	1
24	302611	DECK WHEEL	2

* Order Individual Parts

TREAD PATTERNS

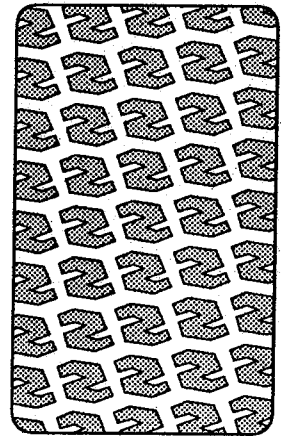
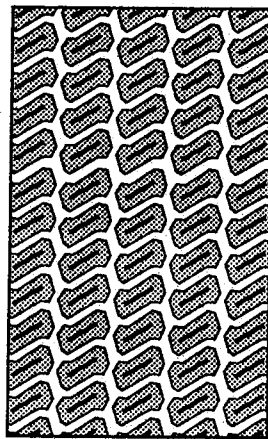
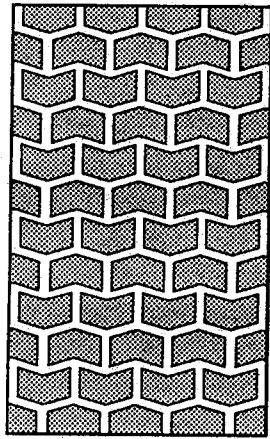
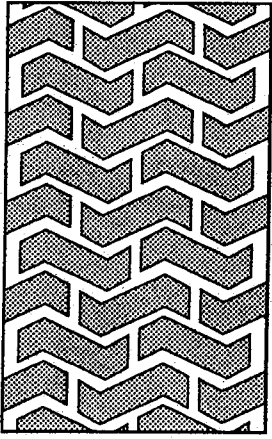

TIRE SIZE	"A"	"B"	"C"	"D"
11 X 4.00 - 5	42295			
13 X 5.00 - 6	41060			
15 X 6.00 - 6	301140	316702	39830	313952
16 X 6.50 - 8		41081		314539
18 X 6.50 - 8				
18 X 9.50 - 8		316701		313950
20 X 8.00 - 8	314584			
20 X 10.00 - 8	58276			313565
20 X 10.00 - 10		55893		
23 X 9.50 - 12	314370			
23 X 9.50 - 12		53655		

ACCESSORIES

Contact the dealer where your tractor was purchased for the available accessories. If you are unable to contact the dealer, write to the address on the front cover of this manual.

Rear Engine Rider

Model	Description
5708-16	Bagger - Fits 32" Side Discharge
5708-17	Bagger - Fits 36" Side Discharge
5709-02	Front Weight Box - holds 35 lbs.
5648-16	Lawn Sweeper w/dump Release

Lawn Tractor

Model	Description
5708-22	Bagger - Fits 30" Side Discharge
5708-13	Bagger - Fits 36", 38", 39" & 45" Side Discharge
5705-04	36" Two-Stage Snowblower - Fits 36", 38", 39", & 45" Side Discharge
5661-06	42" Snowblade - Fits 36", 38", 39", & 45"
5592-00	Tire Chains - 18" x 6.50"
5585-00	Tire Chains - 18" x 9.50" & 20" x 8"
5672-01	Wheel Weights - Front - 1 pr. w/mtg. hdw. - Fits 15" tires
5673-02	Wheel Weights - Rear - 1 pr. w/mtg. hdw. - Fits 18" & 20" tires
5709-03	Front Weights - Fits 30" & 32" Side Discharge
5648-16	Lawn Sweeper w/dump Release

Garden Tractor - Light Ground Engaging

Model	Description
5708-13	Bagger - Fits 36", 38", 39", & 45" Side Discharge
5705-04	36" Two - Stage Snowblower - Fits 36", 38", 39", & 45"
5661-06	42" Snowblade - Fits 36", 38", 39", & 45"
5672-01	Wheel Weights - Front 1 pr. w/mtg. hdw. - Fits 15" tires
5673-02	Wheel Weights - Rear - 1 pr. w/mtg. hdw. - Fits 18" & 20" tires
5648-16	Lawn Sweeper w/dump Release
5667-02	Sleeve Hitch - w/lift bar - Fits 45"
5668-01	Adaptor (sleeve hitch) for use w/23" tires
5706-00	Tire Chains - 20" x 10"
5671-00	Tire Chains - 23" x 9.50"
5672-02	Wheel Weights - Front - 1 pr. w/mtg. hdw. Fits 16" tires
5673-00	Wheel Weights - Rear - 1 pr. w/mtg. hdw. Fits 23" tires
5674-01*	10" One Bottom Moldboard Plow
5675-01*	Cultivator - 7 row - Adj. 6" - 42" width
5676-01*	Disc Harrow - 8" & 11" disc - Adj. width & disc angle
5677-02*	Tiller - 5 H.P. Self-Powered - 28" width

Four Wheel Steer

Model	Description
5708-14	Bagger - Fits 40" & 46" Side Discharge
5705-05	42" One-Stage Snowblower - Fits 40" & 46"
5661-07	48" Snowblade - Fits 40" & 46"
5709-04	Rear Weight Box for 40" & 46"
5648-16	Lawn Sweeper w/dump Release
5706-00	Tire Chains 20" x 10"
5671-00	Tire Chains 23" x 9.50"
5672-02	Wheel Weights - Front - 1 pr. w/mtg. hdw. Fits 16" tires
5673-00	Wheel Weights - Rear - 1 pr. w/mtg. hdw. Fits 23" tires
5672-01	Wheel Weights - Front - 1 pr. w/mtg. hdw. Fits 15" tires
5673-02	Wheel Weights - Rear - 1 pr. w/mtg. hdw. Fits 18" & 20" tires

Four Wheel Steer Garden Tractor

Model	Description
5667-04	Sleeve Hitch - w/lift bar Fits 46"
5674-01*	10" One Bottom Moldboard Plow
5675-01*	Cultivator - 7 row - Adj. 6" - 42" width
5676-01*	Disc Harrow 8" & 11" Disc. Adj. width & disc angle
5677-02*	Tiller 5 H.P. Self-Powered - 28" width
5648-16	Lawn Sweeper w/dump Release

*Requires a sleeve hitch