

# REPAIR PARTS MANUAL

## 38" - 12 H.P. LAWN TRACTOR

### MODEL C3554-250

#### ONE YEAR LIMITED WARRANTY

For one (1) year from date of purchase by the first consumer for residential use (thirty (30) days commercial use), NOMA Outdoor Products Incorporated warrants that it will replace free of charge, including labor, any original part of any NOMA Outdoor Products Incorporated product found to be defective by any authorized Service Dealer or the factory, except the battery which is warranted for ninety (90) days from date of purchase.

This warranty does not cover engine, transmission, transaxle or differential (these items are covered by their manufacturer's own warranty). This warranty does not cover parts that have failed due to normal wear or parts that have failed subject to misuse or abuse. Transportation of the unit or part to and from an authorized Service Dealer or factory is the responsibility of the owner.

A step by step explanation as to what procedure should be followed for this warranty is:

1. If a part becomes defective, contact the store where the unit was purchased for the name and address of the authorized Service Dealer nearest to you.
2. If you cannot locate an authorized Service Dealer, write Service Department of NOMA Outdoor Products Incorporated for the name and address of the authorized Service Dealer in your area or call the Service Department at 1-901-422-1690.
3. Return the defective product, along with proof of purchase to such authorized Service Dealer for replacement of any defective part where covered by this warranty.

There is no other express warranty. Implied warranties, including those of merchantability and fitness for a particular purpose are limited to one (1) year from date of purchase. Liability for incidental or consequential damages are excluded.

Some states do not allow limitations on how long an implied warranty lasts, so the above limitation may not apply to you. Some states do not allow the exclusion of incidental or consequential damages, so the above exclusion may not apply to you. This warranty gives you specific legal rights, and you may have other rights which vary from state to state.

**NOMA Outdoor Products Incorporated**

**Caller 8000**

**Jackson, TN 38308-8000**

#### UNIT PARTS AND SERVICE

Fill in and mail the registration card packed with the unit. For service other than covered in this manual, contact an authorized service dealer. A nationwide parts and service organization has been established to provide locally available parts and service. When ordering repair parts, always give the following information: 1. The Part Name; 2. The Part Number; 3. The Quantity desired; 4. The Full (eight digit) Model Number of the unit. The model number will be found on a plate attached to the unit.



**Look for this symbol. It means - ATTENTION! BECOME ALERT! A HAZARD TO OPERATOR, BYSTANDER, PROPERTY OR EQUIPMENT MAY EXIST.**

**NOMA Outdoor Products Incorporated**  
**Caller 8000**

**Jackson, TN 38308-8000**

Part No. 324300A

50/91

## SAFETY RULES



**CAUTION: ALWAYS DISCONNECT SPARK PLUG WIRES AND PLACE THEM WHERE THEY CANNOT CONTACT SPARK PLUG TO PREVENT ACCIDENTAL STARTING WHEN SETTING-UP, TRANSPORTING, ADJUSTING OR MAKING REPAIRS.**



### IMPORTANT

**THIS CUTTING MACHINE IS CAPABLE OF AMPUTATING HANDS AND FEET AND THROWING OBJECTS. FAILURE TO OBSERVE THE FOLLOWING SAFETY INSTRUCTIONS COULD RESULT IN SERIOUS INJURY OR DEATH.**

#### I. GENERAL OPERATION:

- Know controls and how to stop quickly.
- Read, understand, and follow all instructions in the manual and on the machine before starting.
- Only allow responsible adults, who are familiar with instructions, to operate the machine.
- Wear safety glasses or eye shields when assembling or operating the machine.
- Do not operate machine when barefooted. Always wear substantial footwear, preferably steel-toed shoes.
- Do not wear loose fitting clothing that could get caught in moving parts.
- Clear the area of objects such as rocks, toys, wire, etc., which could be picked up and thrown by the blade(s).
- Be sure the area is clear of other people before mowing. Stop machine if anyone enters the area.
- Never carry passengers.
- Do not mow in reverse unless absolutely necessary. Always look down and behind before and while backing.
- Be aware of the mower discharge direction and do not point it at anyone. Do not operate the mower without either the entire grass catcher or the guard in place.
- Slow down before turning.
- Never leave a running machine unattended. Always turn off blades, set parking brake, stop engine, and remove keys before dismounting.
- Turn off blade(s) when not mowing.
- Stop engine before removing grass catcher or unclogging chute.
- Mow only in daylight or good artificial light.
- Do not operate the machine while under the influence of alcohol or drugs.
- Watch for traffic when operating near or crossing roadways.
- Use care when mowing around a fixed object to prevent the blade(s) from striking it. Never deliberately run over any foreign object.
- Use extra care when loading or unloading the machine into a trailer or truck.
- Use care when pulling loads or using heavy equipment.
  - a. Use only approved drawbar hitch points.
  - b. Limit loads to those that you can safely control.
  - c. Do not turn sharply. Use care when backing.
  - d. Use counterweight(s), wheel weight or tire chains when suggested in attachment(s) instructions.

#### II. SLOPE OPERATION:

Slopes are a major factor related to loss-of-control and tip-over accidents, which can result in severe injury or death. *All slopes require extra caution.* If you cannot back up the slope or if you feel uneasy on it, do not mow it.

##### DO

- Mow up and down slopes, not across.
- Remove obstacles such as rocks, tree limbs, etc.
- Watch for holes, ruts, or bumps. Uneven terrain could overturn the machine. *Tall grass can hide obstacles.*
- Use slow speed. Choose a low gear so that you will not have to stop or shift while on the slope.
- Follow the manufacturer's recommendations for wheel weights or counterweights to improve stability.
- Use extra care with grass catchers or other attachments. These can change the stability of the machine.
- Keep all movement on the slopes *slow* and *gradual*. Do not make sudden changes in speed or direction.
- Avoid starting or stopping on a slope. If tires lose traction, turn off the blade(s) and proceed slowly *straight* down the slope.

##### DO NOT

- Do not turn on slopes unless necessary, and then slowly and gradually downhill, if possible.
- Do not mow near drop-offs, ditches or embankments. The

mower could suddenly turn over if a wheel is over the edge of a cliff or ditch, or if an edge caves in.

- Do not mow on wet grass. Reduced traction could cause sliding.
- Do not try to stabilize the machine by putting your foot on the ground.
- Do not use grass catcher on steep slopes.

#### III. CHILDREN:

Tragic accidents can occur if the operator is not alert to the presence of children. Children are often attracted to the machine and the mowing activity. *Never* assume that children will remain where you last saw them.

- Keep children out of the mowing area and under the watchful care of another responsible adult.
- Be alert and turn machine off if children enter the area.
- Before and when backing, look behind and *down* for small children.
- Never carry children. They may fall off and be seriously injured or interfere with safe machine operation.
- Never allow children to operate the machine.
- Use extra care when approaching blind corners, shrubs, trees, or other objects that may obscure vision.

#### IV. SERVICE:

- Use extra care in handling gasoline and other fuels. They are flammable and vapors are explosive.
  - a. Use only an approved container.
  - b. Never remove gas cap or add fuel with the engine running. Allow engine to cool before refueling. Do not smoke.
  - c. Never refuel the machine indoors.
  - d. Never store the machine or fuel container inside where there is an open flame, such as in a water heater.
- Check fuel supply before each use allowing space for expansion as the heat of the engine and/or sun can cause gasoline to expand and overflow the tank.
- Use extra care when handling battery acid. Acid contact with skin may cause severe burns. Eye contact may cause blindness.
- Use extra care when servicing the battery. Explosive gas is produced in the battery. Do not service the battery while smoking or near an open spark or flame. This may cause the battery to explode causing serious injury.
- Never run a machine inside a closed area. Exhaust fumes contain CARBON MONOXIDE, an ODORLESS and DEADLY GAS.
- Keep nuts and bolts, especially blade attachment bolts, tight and keep equipment in good condition.
- Never tamper with safety devices. Check their operation regularly.
- Do not change the engine governor settings or overspeed engine.
- Reduce fire hazards. Keep machine free of grass, leaves, or other debris build-up. Clean up oil or fuel spillage. Allow machine to cool before storing.
- Stop and inspect the equipment if you strike an object. Repair, if necessary, before restarting.
- Never make adjustments or repairs with the engine running.
- Grass catcher components are subject to wear, damage, and deterioration, which could expose moving parts or allow objects to be thrown. Frequently check components and replace with manufacturer's recommended parts, when necessary.
- Mower blade(s) are sharp and can cut. Wrap the blade(s) or wear gloves, and use extra caution when servicing them.
- Check brake operation frequently. Adjust and service as required.



**LOOK FOR THIS SYMBOL TO POINT OUT IMPORTANT SAFETY PRECAUTIONS. IT MEANS--ATTENTION!!! BECOME ALERT!!! YOUR SAFETY IS INVOLVED.**

## OWNER'S INFORMATION

Record the following information about your unit so that you will be able to provide it in case of loss or theft.

MODEL NUMBER:  -  (Enter complete 8 digit number from model plate on unit)  
PURCHASE DATE: \_\_\_ / \_\_\_ / \_\_\_ CODE NO.: \_\_\_\_\_ SERIAL NO.: \_\_\_\_\_  
DEALER'S NAME AND ADDRESS: \_\_\_\_\_  
CITY: \_\_\_\_\_ STATE: \_\_\_\_\_ TELEPHONE: \_\_\_\_\_

### CONTENTS OF SHIPPING CARTON

- 1 - Lawn Tractor with 38 inch Mower Deck
- 1 - Operator's Manual
- 1 - Repair Parts Manual
- 1 - Engine Manual
- 1 - Grass Catcher Manual
- 1 - Steering Wheel (see Note)
- 1 - Seat (see Note)
- 1 - Bag of Assembly Parts Containing (see Note):
  - 1 - Oil Drain Trough
  - 1 - Steering Sleeve
  - 4 - 5/16 x 3/4 inch Hex Head Screws
  - 4 - 5/16 inch Split Lockwashers
  - 4 - 11/32 inch Flatwashers
  - 1 - Roll Pin

**NOTE:** Refer to page 22 (Customer Assembly Parts) for more detailed description.

### TOOLS REQUIRED FOR ASSEMBLY

- 2 - 7/16 inch Wrenches (or adjustable wrench)
- 1 - 1/2 inch Wrench (or adjustable wrench)
- 1 - Small Phillips Screwdriver with a 1/4 inch shank
- 1 - Hammer

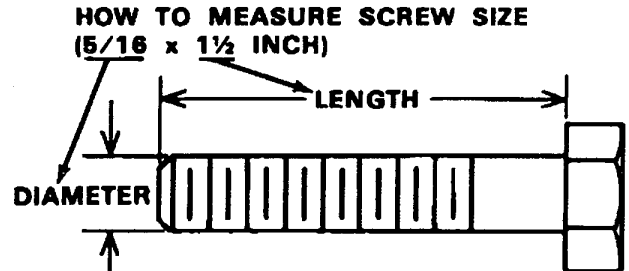

## DANGER



This lawn tractor can be dangerous if carelessly used.

Read your Operator's Manual thoroughly before operating your lawn tractor.

Always wear safety glasses or eye shields while assembling or operating your lawn tractor.

**DO NOT** carry passengers at any time.

Keep your hands, feet, hair and loose clothing away from the discharge area, the underside of the mower deck or any moving parts while the engine is running.

**DO NOT** allow children or young teenagers to operate or be near your lawn tractor while it is operating.

ALWAYS GIVE THE FOLLOWING INFORMATION WHEN ORDERING REPAIR PARTS:

1. The PART NUMBER; 2. The PART NAME; 3. QUANTITY DESIRED; 4. The MODEL NUMBER (As shown on Model Plate).

SEND PART ORDERS AS PER INSTRUCTIONS ON THE FRONT PAGE.

**DO NOT USE KEY NUMBERS WHEN ORDERING REPAIR PARTS, ALWAYS USE PART NUMBERS.**

All replacement parts will be supplied in current production colors or in a neutral color.

A handling fee is applicable to small parts orders.

YOUR UNIT IS RIGHT HAND (RH) OR LEFT HAND(LH) AS YOU STAND BEHIND IT.

# 38" LAWN TRACTOR MODEL C3554-250

## CHASSIS & HOOD ASSEMBLY

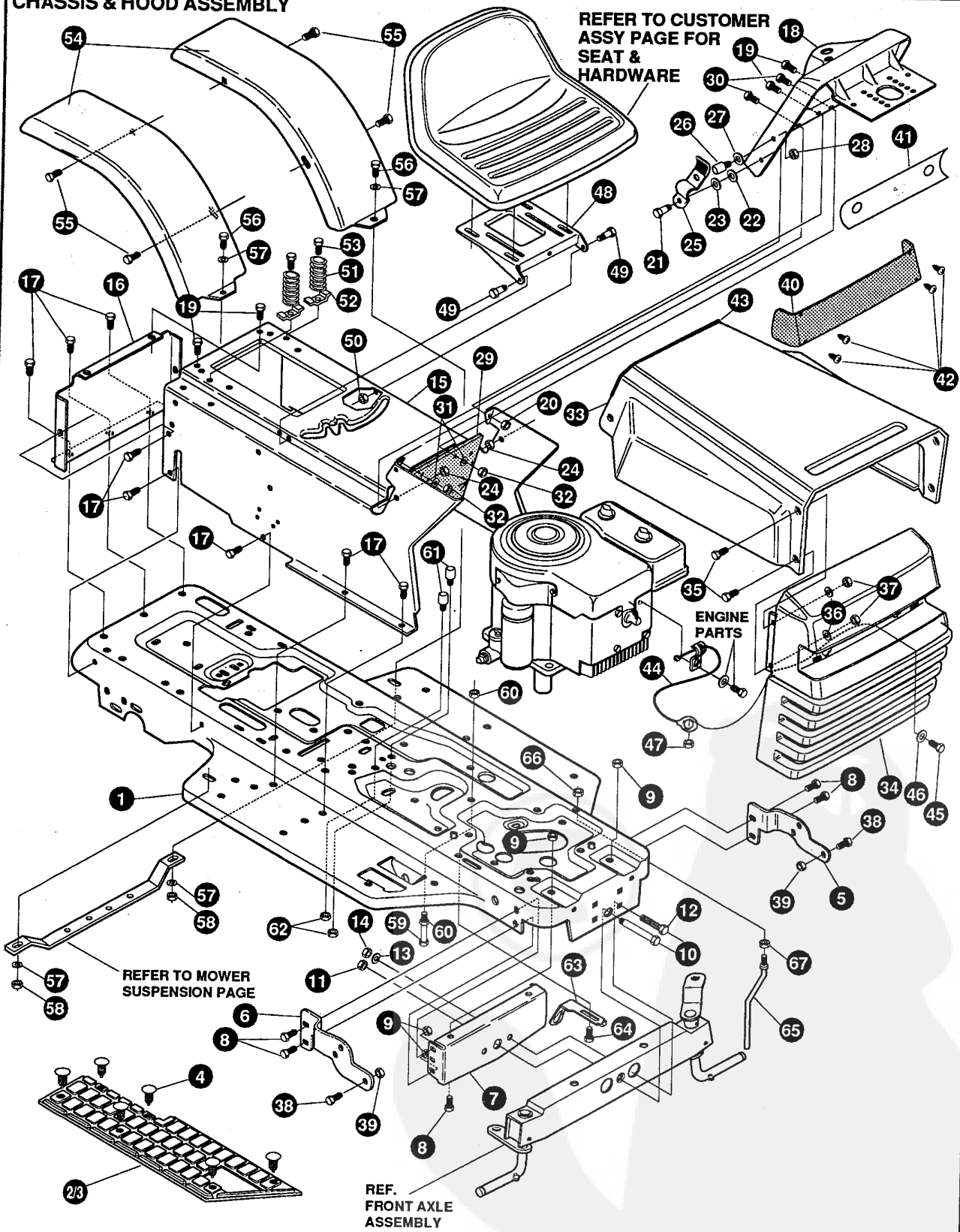

**NOTE: ALWAYS USE ORIGINAL EQUIPMENT PARTS.** Use of service/replacement parts other than original equipment parts may void your warranty.

**ALL UNNUMBERED ITEMS ARE INTERCHANGABLE WITH OPPOSITE SIDE**

321854A

### 38" LAWN TRACTOR MODEL C3554-250

key#	part#	description	qty.
1	314883-863	FRAME,MAIN SF RIDER	1
2	310003	FOOTPAD,LH	1
3	310004	FOOTPAD,RH	1
4	309235	FASTENER, RATCHET	12
5	316199	BRACKET,GRILLE L.H.	1
6	316200	BRACKET,GRILLE R.H.	1
7	313437	BRKT,SUPT FRT AXLE-	1
8	• 56030	SCREW, 5/16-18X.75WDFLLK	6
9	• 55273	NUT, 5/16-18 HXWDFLLK	6
10	29616	BOLT, .625X2.875 SPSH 1/2-20	1
11	• 274654	NUT, 1/2-20 REGHXCTRLK	1
12	• 122201	SCREW, 3/8-16X2.75 HHC	2
13	2483	WASHER,.39IDX1.25DX.07 BELLVIL	2
14	• 1499	NUT, 3/8-16 REGHXCTRLK	2
15	314491-863	CONSOLE,SF DYNA STYLE TOPSH	1
16	56235-863	CONSOLE, REAR COVER	1
17	• 995346	SCREW, 1/4-20X .50 WAHHTAP	15
18	320466-863	DASH,SF NOMA DYNA STYLING	1
19	• 995338	SCREW, 1/4-20X .63 HHWATAP	2
20	50352	NUT 1/4-20 WDFLLK TOP LOCK	2
21	8482	BOLT, .375X .156 HSH 5/16-18	2
22	• 120394	WASHER, FLAT .406X .81X.065	2
23	• 120393	WASHER, FLAT .344X .69X.065	2
24	• 1498	NUT, 5/16-18 REGHEXCTRLK	2
25	57159	LATCH, .94WDX.047 ASSY HOOD	2
26	53446	PIN, 5/16-18 HOOD LATCH	2
27	• 138538	WASHER, REGINTLK.320X.61X.03	2
28	• 45174	NUT, 5/16-18 HEXWDFLLK WHIZ	2
29	312306	BAFFLE CONSOLE SOUND EXPORT	1
30	• 300314	SCREW, 1/4-20X .88WAHHTAP	2
31	• 120393	WASHER, FLAT .344X .69X.065	2
32	• 1502	NUT, 1/4-20 REGHEXCTRLK	2
33	314538-863	HOOD	1
34	314476	GRILLE DYNA-PRO	1
35	• 274672	SCREW, 1/4-20X .63 WAHHC	4
36	• 120392	WASHER, FLAT .281X .63X.065	4
37	• 1502	NUT, 1/4-20 REGHEXCTRLK	4
38	36149	BOLT, .375X .500 HSH 5/16-18	2
39	• 1498	NUT, 5/16-18 REGHEXCTRLK	2
40	302333	LENS HEADLAMP	1
41	314948	FOIL,LENS DYNA-PRO REFLECTOR	1
42	• 57796	SCREW, #6 X .50 PLASTITE	4
43	47453	EDGING,WIDE BLK	25"
44	310749	LANYARD,HOOD	1
45	121887	SCREW 1/4-20 X .75 HHC	1
46	120392	FLATWASHER .281 X .63 X .065	1
47	1502	LOCKNUT 1/4-20	1
48	58367-853	PLATE, SEAT F-5 SF & LF	1
49	20507	BOLT, .437X .156 HSH 5/16-18	2
50	• 1498	NUT, 5/16-18 REGHEXCTRLK	2
51	56220	SPRING,1.43X2.38X.162 COM SEAT	2
52	1341	CLAMP,SPRING 1.17"ID	2
53	• 995346	SCREW, 1/4-20X .50 WAHHTAP	2
54	43970-863	FENDER	2
55	• 995346	SCREW, 1/4-20X .50 WAHHTAP	4
56	• 122017	SCREW, 5/16-18X1.00 HHC	2
57	• 446363	WASHER, FLAT .375X .88X.082	4
58	• 1498	NUT, 5/16-18 REGHEXCTRLK	2
59	• 427342	SCREW, 3/8-16X 6.50 HHC	1
60	• 1499	NUT, 5/16-18 REGHEXCTRLK	2
61	• 53446	PIN 5/16-18	2
62	• 271184	NUT, 5/16-18 HEX KEPS	2
63	• 312953	BRACKET,SWITCH MOUNT	1
64	• 995346	SCREW, 1/4-20X .50 WAHHTAP	1
65	• 50653	GUIDE, BELT	1
66	• 41529	NUT, 3/8-16 HXCTRLKJAM	1
67	• 271190	NUT, 3/8-16 HEXKEPS	1
68	322837	Operator's manual, English (Not Illustrated)	1
69	324300	Parts Manual, English (Not Illustrated)	1
70	317077	Grass Catcher- English/French, 5708-1802	1

• Indicates STANDARD HARDWARE ITEMS.

# 38" LAWN TRACTOR MODEL C3554-250

## MOWER SUSPENSION ASSEMBLY

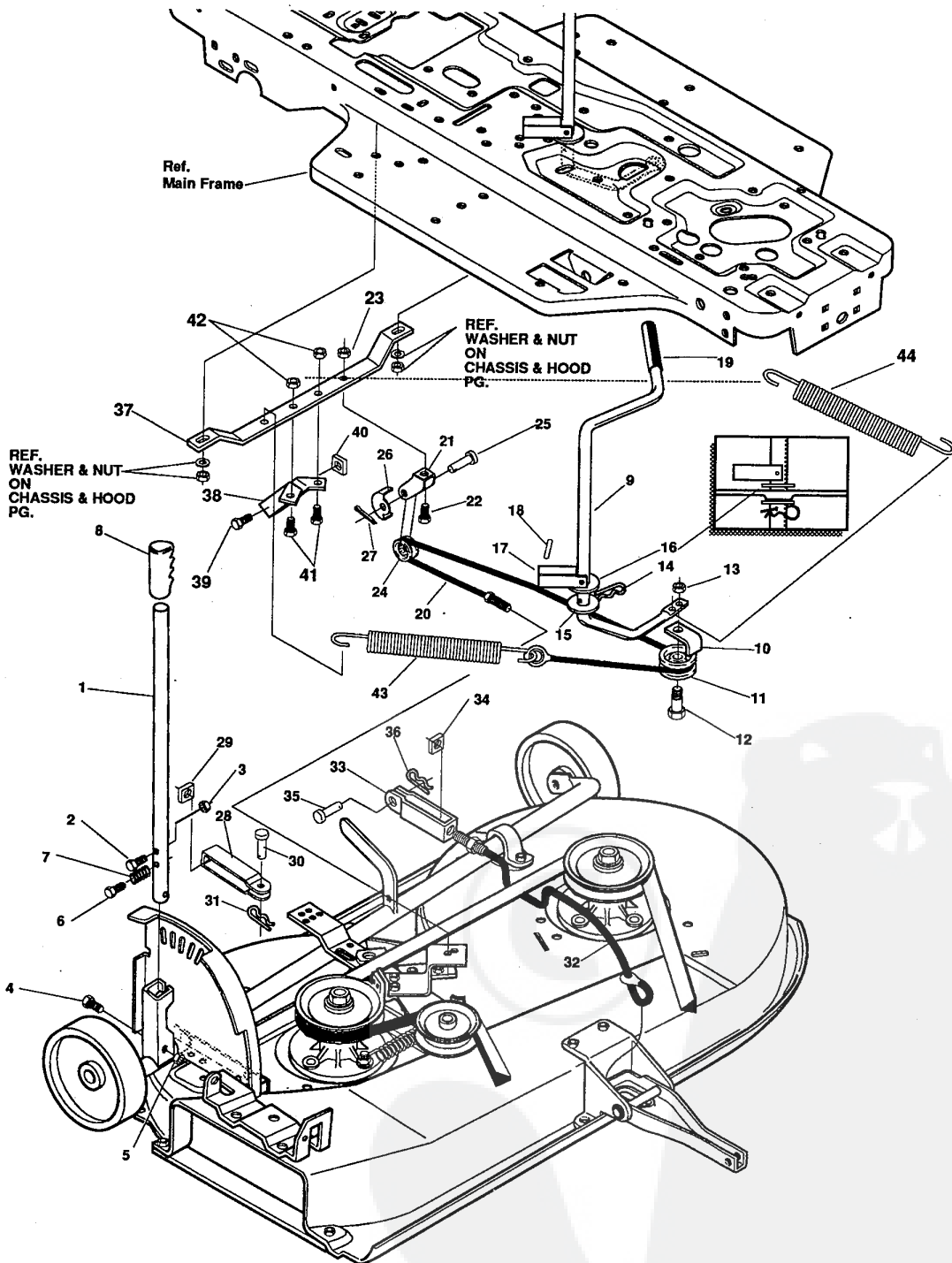

**NOTE:** ALWAYS USE ORIGINAL EQUIPMENT PARTS. Use of service/replacement parts other than original equipment parts may void your warranty.

**ALL UNNUMBERED ITEMS ARE INTERCHANGABLE WITH OPPOSITE SIDE**

314836G

### 38" LAWN TRACTOR MODEL C3554-250

key#	part#	description	qty.
1	313637	LEVER, DECK HEIGHT ADJUST	1
2	57324	BOLT, 5/16-18X.56	1
3	◇271184	NUT, 5/16-18 HEXKEPS	1
4	◇122040	SCREW, 5/16-18X1.50 HHC	1
5	◇1498	NUT, 5/16-18 REGHEXCTRLK	1
6	◇995346	SCREW, 1/4-20X .50 HHWATAP	1
7	57319	SPRING, .70X.85X.091	1
8	56924	GRIP, .75 X 4.25 HANDLE	1
9	314877	LEVER, CLUTCH	1
10	1288	BRKT, CABLE RETAINER	1
11	39298	PULLEY, .906X.305 NYLON	1
12	58336	BOLT, .375X .375 HSH 1/4-20	1
13	◇1502	NUT, 1/4-20 REGHEXCTRLK	1
14	8260	PIN, HAIR .091 DIA X 1.66LG	1
15	◇996425	WASHER, FLAT .515X .88X.064	1
16	◇22265	WASHER, FLAT .515X1.38X.119	1
17	305225	STOP, PTO ENGAGEMENT	1
18	455481	PIN, SPRING.187DIA X 1.00LG	1
19	46478	GRIP, HAND .50ID 3.37	1
20	314520	CABLE, CLUTCH 30.25"	1
21	49320	CABLE, PULLEY SUPPORT	1
22	◇120228	SCREW, 5/16-18X .63 HHC	1
23	◇1498	NUT, 5/16-18 REGHEXCTRLK	1
24	39298	PULLEY, .906X.305 NYLON	1
25	49332	PIN, CLEVIS .375DX.81LG	1
26	314523	GUARD, PULLEY	1
27	121222	PIN, COTTER .090/.086X.75LG	1
28	9405	CLEVIS, LIFT CABLE	1
29	◇120372	NUT, 1/4-20 REGSQ	1
30	39522	PIN, CLEVIS .312 X .812	1
31	56180	PIN, HAIR .091 DIA X 1.62LG	1
32	301718	CABLE, LIFT 22.7 LG F-5 20X10-8	1
33	9405	CLEVIS, LIFT CABLE	1
34	◇120372	NUT, 1/4-20 REGSQ	1
35	39522	PIN, CLEVIS .312 X .812	1
36	56180	PIN, HAIR .091 DIA X 1.62LG	1
37	314880-930	GUIDE, SUPPORT, DECK	1
38	314876	BRACKET, DECK GUIDE	1
39	◇122040	SCREW, 5/16-18X1.50 HHC	1
40	◇1498	NUT, 5/16-18 REGHEXCTRLK	1
41	◇122017	SCREW, 5/16-18X1.00 HHC	2
42	◇1498	NUT, 5/16-18 REGHEXCTRLK	2
43	300473	SPRING, TENSION	1
44	316648	SPRING .071 X .62 X 12.88	1

◇STANDARD HARDWARE ITEMS

# 38" LAWN TRACTOR MODEL C3554-250

## STEERING ASSEMBLY

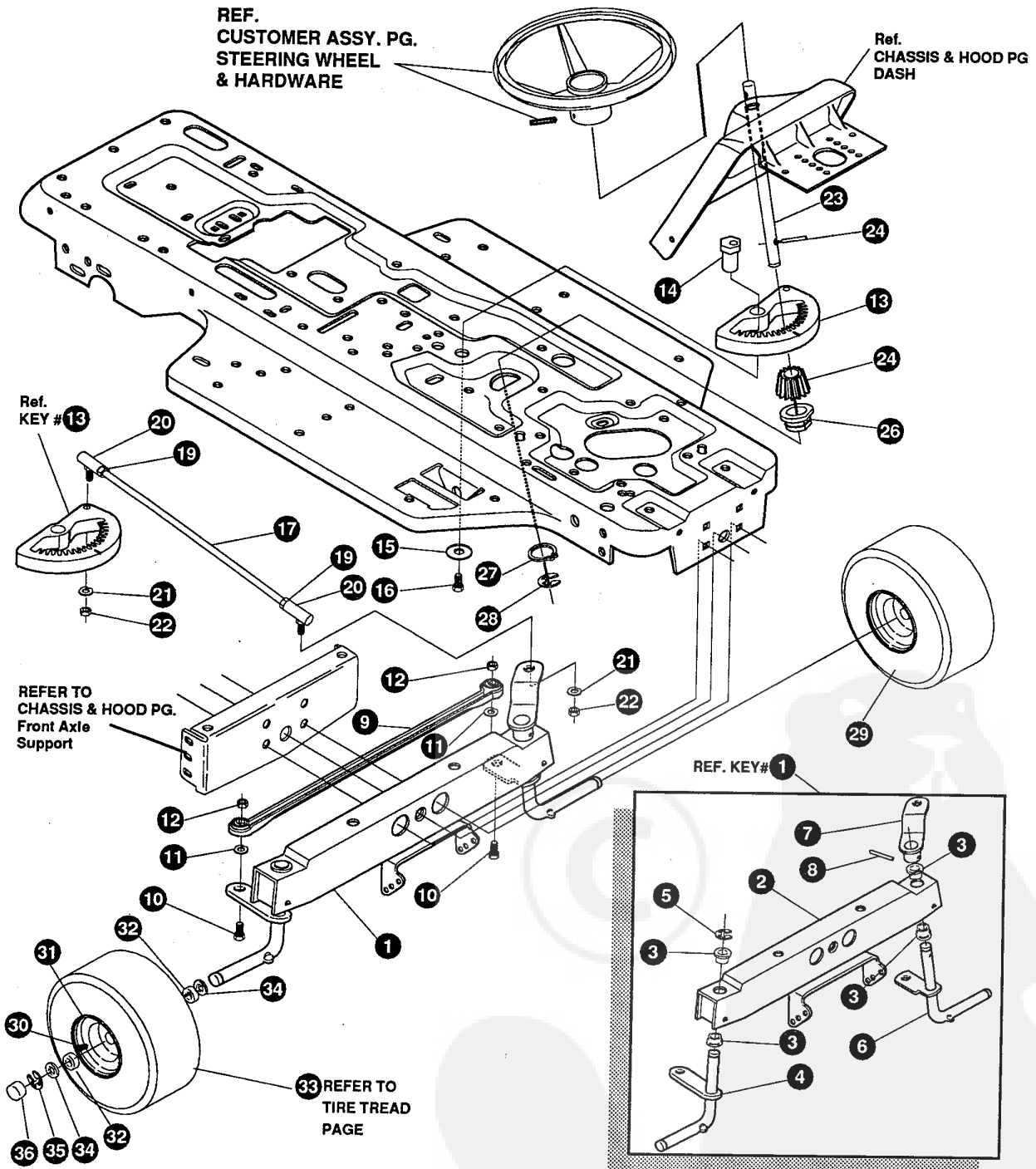

**NOTE:** ALWAYS USE ORIGINAL EQUIPMENT PARTS. Use of service/replacement parts other than original equipment parts may void your warranty.

**ALL UNNUMBERED ITEMS ARE INTERCHANGABLE WITH OPPOSITE SIDE**

319475C



### 38" LAWN TRACTOR MODEL C3554-250

key#	part#	description	qty.
1.	*	FRONT AXLE ASSEMBLY SF	1
2.	318883	AXLE FRONT	1
3.	50546	BEARING FLANGE	4
4.	310368	SPINDLE,RH	1
5.	36625	RING,RETEX	1
6.	310367	SPINDLE,LH	1
7.	49447	ARM,STEERING LH	1
8.	454565	PIN,SPRING	1
9.	302691	TIE ROD	1
10.	• 122145	SCREW, 3/8-16X1.25 HHC	2
11.	120382	WASHER, .393X.68X.10 REGSPTLK	2
12.	• 1499	NUT, 3/8-16 REGHCTRLK	2
13.	304245	SECTOR GEAR	1
14.	44011	BOLT, .750X1.40 SPSH	1
15.	2483	WASHER, .39IDX1.25ODX.07	1
16.	39573	SCREW, 3/8-24X1.00 NYL	1
17.	56191	DRAG LINK ASSEMBLY	1
18.	56190	DRAG LINK	1
19.	• 124925	NUT, 3/8-24 REGHEXJAM	2
20.	21275	BALL JOINT	2
21.	• 120382	WASHER, EGSPTLK	2
22.	120369	NUT, 3/8-24 REGHEX	2
23.	314109-930	STEERING SHAFT	1
24.	44009	PINION,STEERING SHAFT	1
25.	454565	PIN,SPRING	1
26.	54902	BEARING,1.370X.50 FLANGE STEERING	1
27.	39492	RING,RETEX 1.27X.05	1
28.	36625	RING,RETEX .57X.05	1
29.	41059	ASSEMBLY, TIRE & RIM	2
30.	24167	VALVE STEM	1
31.	39937	WHEEL W/BEARING	1
32.	39979	BEARING, 1.380DX.753ID FLANGE	2
33.		REFER TO TIRE TREAD PAGE	
34.	642	WASHER,FLAT .755X1.31X.075	4
35.	36625	RING,RETEX .57X.05	2
36.	40394	HUB CAP	2

• STANDARD HARDWARE ITEMS

\* Order Individual Parts

# 38" LAWN TRACTOR MODEL C3554-250

## MOTION DRIVE ASSEMBLY

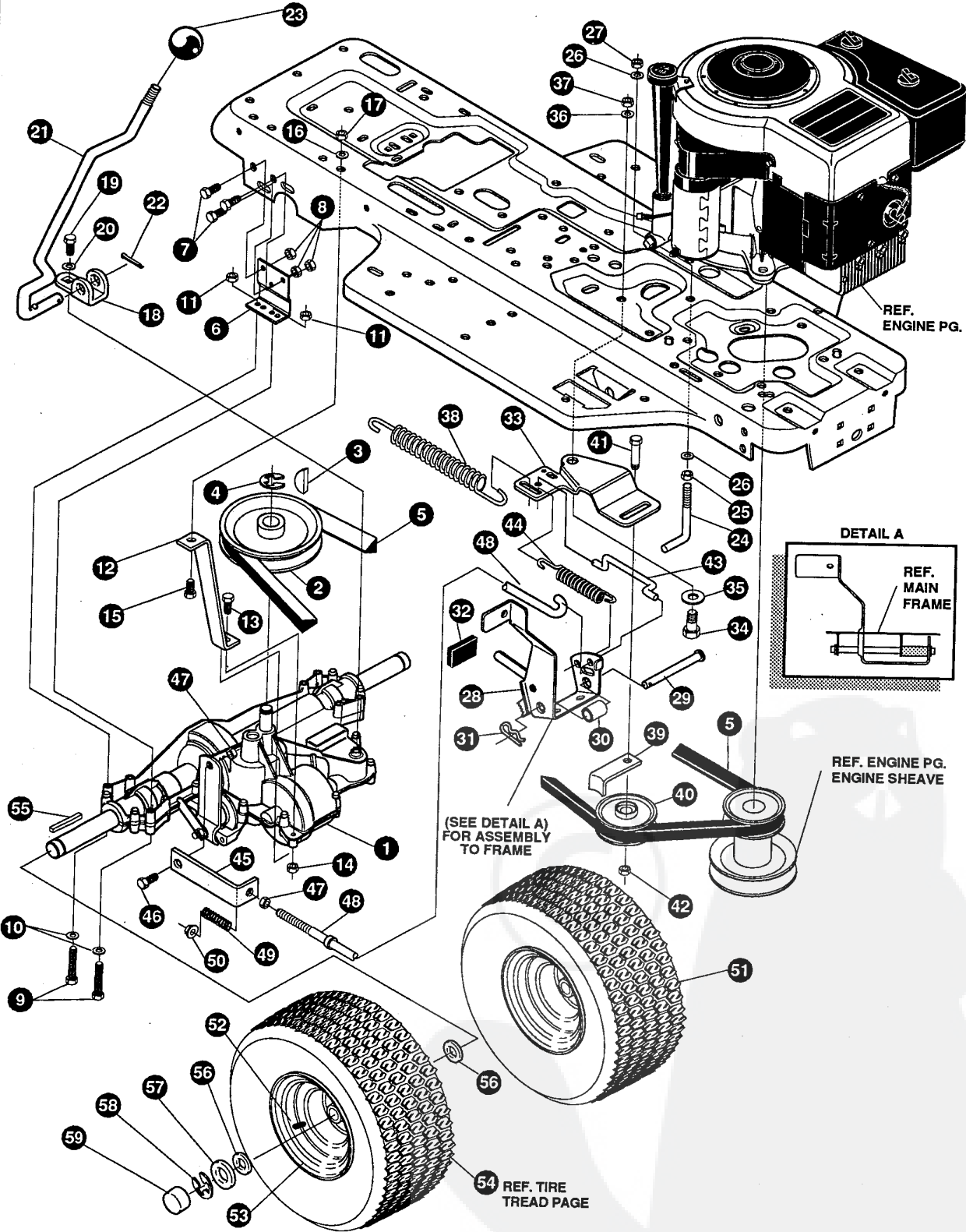

**NOTE: ALWAYS USE ORIGINAL EQUIPMENT PARTS.**  
Use of service/replacement parts other than original equipment parts may void your warranty.

**ALL UNNUMBERED  
ITEMS ARE INTERCHANGABLE  
WITH OPPOSITE SIDE**

321848A

### 38" LAWN TRACTOR MODEL C3554-250

key#	part#	description	qty.
1.	*	TRANSAXLE P915-5SP SF FER	1
2.	302745	PULLEY, IDLER V4L 6.60	1
3.	3021	KEY, WDRF 606 .750X.187X.312	1
4.	22053	RING, RETEX .58X.035TRU5100-62	1
5.	54758	BELT, V 4L 82.00 SF DRIVE	1
6.	53768-853	MP BRACKET,TRANSAXLE	2
7.	120228	SCREW, 5/16-18X .63 HHC	6
8.	1498	NUT, 5/16-18 REGHEXCTRLK	6
9.	180089	SCREW, 5/16-18X2.25 HHC	4
10.	120393	WASHER, FLAT .344X .69X.065	4
11.	1498	NUT, 5/16-18 REGHEXCTRLK	4
12.	313587-930	MF BRACKET, T/A TORQ. 915 S/F	1
13.	180087	SCREW, 5/16-18X2.00 HHC	1
14.	1498	NUT, 5/16-18 REGHEXCTRLK	1
15.	122017	SCREW, 5/16-18X1.00 HHC	1
16.	138485	WASHER, EXLK .320X.61X.03	1
17.	1498	NUT, 5/16-18 REGHEXCTRLK	1
18.	310753	MH BRACKET, SHIFT P920-3SP	1
19.	56255	SCREW, 1/4-28X .75 NYLHHC	1
20.	57157	WASHER,.750 X .250 SP-TRANSAXLE	1
21.	313934	LEVER, SHIFT 915 T/A S/F	1
22.	137185	PIN, COTTER .125 DIA X1.00LG	1
23.	55514	KNOB, ROUND 1.50 DIA BLACK	1
24.	49896	MF BELT GUIDE	1
25.	271184	NUT, 5/16-18 HEXKEPS	1
26.	120393	WASHER, FLAT .344X .69X.065	2
27.	1498	NUT, 5/16-18 REGHEXCTRLK	1
28.	302603-853	SF ASSY,BRAKE PEDAL S.F.	1
29.	319676	PIN,CLEVIS .5 DIA,4.87LG,ZN PL	1
30.	302601	SPACER, SLEV .53 X .62X1.406	1
31.	56180	PIN, HAIR .091 DIA X1.62LG	1
32.	48761	PAD,CLUTCH/BRAKE PEDAL	1
33.	1306	MF IDLER ARM BRKT TRACTION SF	1
34.	41890	BOLT, .625X .218 HSH 5/16-18Z	1
35.	4107	WASHER, FLAT .635X1.31X.07	1
36.	45602	WASHER, FLAT .333X .87X.119	1
37.	1498	NUT, 5/16-18 REGHEXCTRLK	1
38.	49276	SPRING,3/4 ODX6.75X.091 TENSIO	1
39.	39659	MF RETAINER,BELT	1
40.	35374	PULLEY, IDLER V4L 3.06X .62	1
41.	45892	BOLT, 3/8-16X1.50 CARR	1
42.	1499	NUT, 3/8-16 REGHXCTRLK	1
43.	43980	ROD, .268 DIA CLUTCH	1
44.	50562	SPRING,3/8ODX1.625X.055 TENSIO	1
45.	322613-930	BRACKET, TRACTION BRAKE S/F	1
46.	46824	BOLT, .500X .188 HSH 5/16-18Z	1
47.	1498	NUT, 5/16-18 REGHEXCTRLK	1
48.	322614-930	ROD, BRAKE 915 T/A SF	1
49.	53820	SPRING, CLUTCH .625 OD	1
50.	50352	NUT, 1/4-20 WDFLLK TOPLOCK	1
51.	41104	TIRE & RIM, PU 18X9.5X8 TURWHI	2
52.	24167	VALVE STEM	1
53.	41105	WHEEL&HUB ASSY 9.50X8 WHITE	1
54.		REFER TO TIRE TREAD PAGE	
55.	52928	KEY, SQUARE .187SQX2.25LG	2
56.	642	WASHER, FLAT .755X1.31X.075	4
57.	42815	WASHER, FLAT .755X1.53X.07	2
58.	36625	RING, RETEX .57X.05TRU5133-75	2
59.	40394	HUB CAP, 1.500ID X 7/8LG	2

• STANDARD HARDWARE ITEMS.

\* Contact Your Nearest Transaxle Dealer For Parts & Service.

# 38" LAWN TRACTOR MODEL C3554-250

## ENGINE & CONTROL

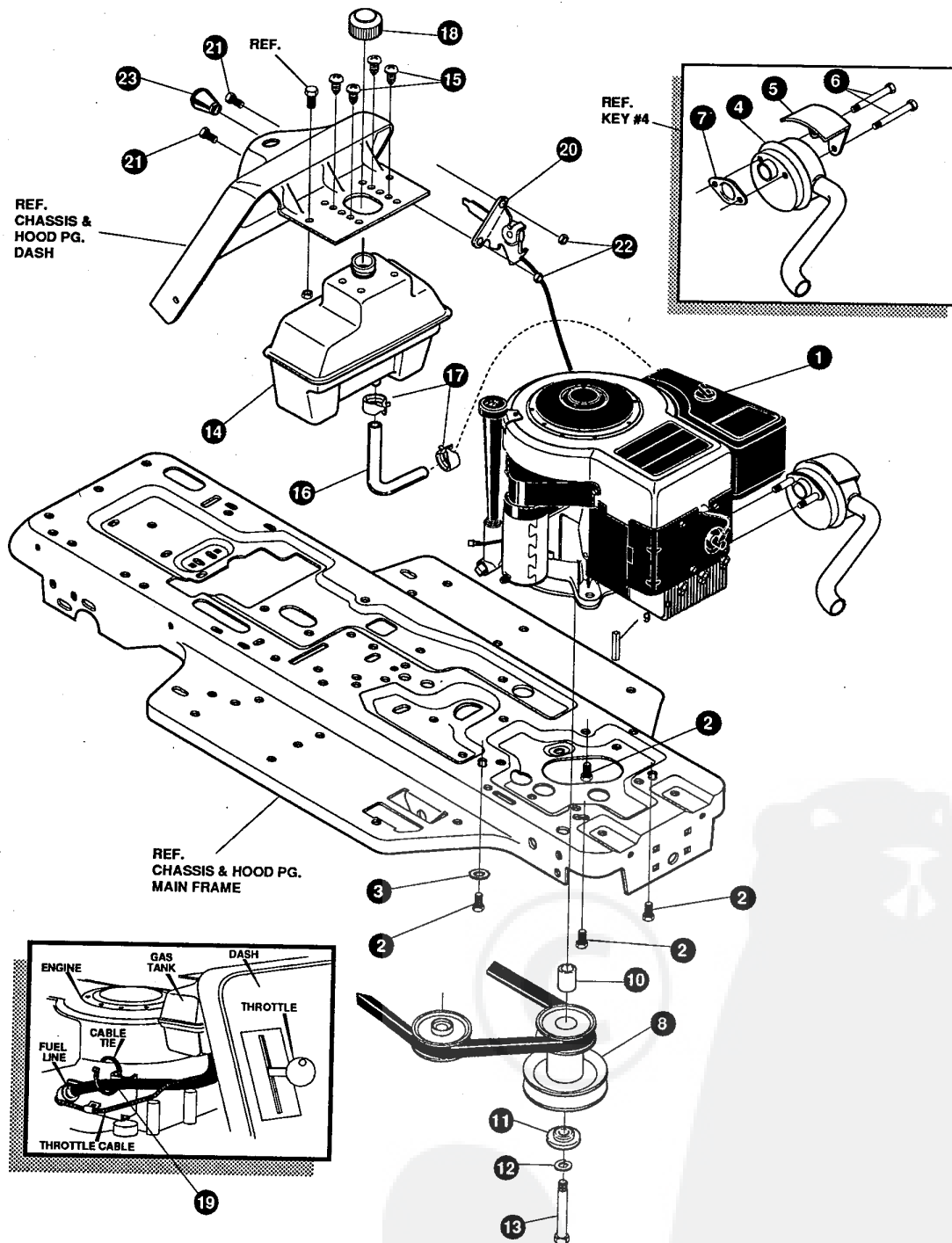

**NOTE: ALWAYS USE ORIGINAL EQUIPMENT PARTS.**  
Use of service/replacement parts other than original equipment parts may void your warranty.

**ALL UNNUMBERED  
ITEMS ARE INTERCHANGABLE  
WITH OPPOSITE SIDE**

322132B

### 38" LAWN TRACTOR MODEL C3554-250

key#	part#	description	qty.
1	ENGINE	12 HP B&S (SEE ENGINE MANUAL)	1
2	• 50947	SCREW, 3/8-16X1.25 WAHTAP	4
3	138489	WASHER, EXLK .384X.69X.04	1
4	305367	MUFFLER-LO TONE NELSON EXPORT	1
5	54767	SHIELD, HEAT, FOR ROUND MUFFLER	1
6	• 173063	SCREW, 5/16-18X3.50 HHC	1
7	46708	GASKET, MUFFLER	1
8	310250	PULLEY, ENG 4.00 OFFSET	1
9	303151	KEY, SQUARE .249SQX4.50LG	1
10	304246	SPACER, 1.01X1.484 ENGIN PULLEY	1
11	56431	WASHER, .980IDX1.38ODX.437PILOT	1
12	120383	WASHER, REGSPTLK.459X.78X.12	1
13	• 433146	SCREW, 7/16-20X4.25 HHC BLK PH	1
14	314989	TANK, FUEL 1 GAL	1
15	• 49050	SCREW, 1/4-10X .75PHPNTAPGR2BK	4
16	47452	GAS LINE .25ID BULK LENGTH	12 in.
17	48672	CLAMP, FUEL LINE	2
18	46704	GAS CAP 1-1/2-7 THD BLK	1
19	57444	TIE CABLE	1
20	320031	THROTTLE CONTROL	1
21	• 35291	SCREW, 10-24X .50 SLHHMA	1
22	• 271166	NUT, #10-24 HEXKEPS	2
23	50607	KNOB, ROUND THROTTLE	2

• Indicates STANDARD HARDWARE ITEMS.

# 38" LAWN TRACTOR MODEL C3554-250

## PRE-PAINTED DECK

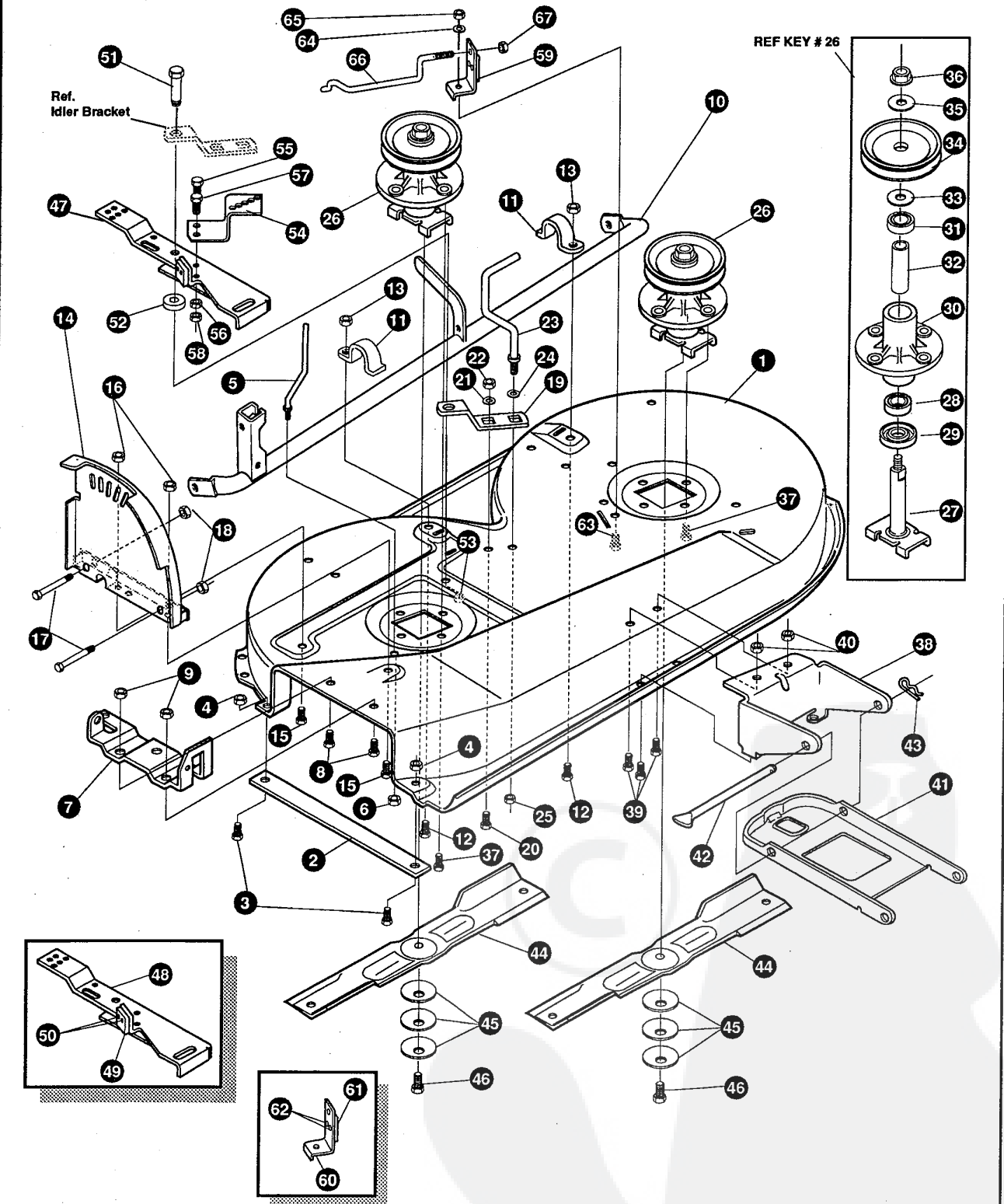

**NOTE: ALWAYS USE ORIGINAL EQUIPMENT PARTS.** Use of service/replacement parts other than original equipment parts may void your warranty.

**ALL UNNUMBERED ITEMS ARE INTERCHANGABLE WITH OPPOSITE SIDE**

319478B

### 38" LAWN TRACTOR MODEL C3554-250

key#	part#	description	qty.
1.	315610-853	DECK,MOWER 38"SD	1
2.	57314	BAR, SKID	1
3.	126216	BOLT, 5/16-18X .75 CARR	2
4.	• 271184	NUT, 5/16-18 HEXKEPS	2
5.	57318	GUIDE, BELT 5/16-18 THD	1
6.	• 1498	NUT, 5/16-18 REGHEXCTRLK	1
7.	57360	BRACKET, CHUTE	1
8.	• 120834	SCREW, 5/16-18X .50 HHC	2
9.	• 1498	NUT, 5/16-18 REGHEXCTRLK	2
10.	308641	TUBE, ASSY TORQUE	1
11.	51985	SUPPORT,PIVOT TUBE	2
12.	• 120228	SCREW, 5/16-18X .63 HHC	2
13.	• 1498	NUT, 5/16-18 REGHEXCTRLK	2
14.	308195	QUADRANT,HEIGHT ADJ.,DECK LIFT	1
15.	• 120228	SCREW, 5/16-18X .63 HHC	2
16.	• 1498	NUT, 5/16-18 REGHEXCTRLK	2
17.	• 122040	SCREW, 5/16-18X1.50 HHC	2
18.	• 1498	NUT, 5/16-18 REGHEXCTRLK	2
19.	300179	BRACKET, IDLER SUPPORT	1
20.	• 180077	SCREW, 5/16-18X .75 HHC	1
21.	120393	WASHER, FLAT .344X .69X.065	1
22.	• 44108	NUT, 5/16-18 HWDFLCTRLK	1
23.	314935	GUIDE, BELT 5/16-18THD	1
24.	120393	WASHER, FLAT .344X .69X.065	1
25.	• 44108	NUT, 5/16-18 HWDFLCTRLK	1
26.	56424	QUILL ASSY, 36/39/40/43	2
27.	56425	SHAFT/SADDLE 36"	1
28.	49562	BRNG, BALL .669IDX1.575ODX.472	1
29.	50616	DUST SHIELD	1
30.	55547	QUILL CASTING (1046)	1
31.	49562	BRNG, BALL .669IDX1.575ODX.472	1
32.	50818	SPACER, SLEV .669X .88X3.797	1
33.	51449	SPACER, SLEV .672X .93X .438PM	1
34.	56390	BF/BP PULLEY,26/36" QUILL V5L	1
35.	56365	WASHER, SPECIAL QUILL	1
36.	• 1282	NUT, 7/16-20 WDFLLK	1
37.	• 50634	SCREW, 5/16-18X .88 WAHHTAP	8
38.	320070	BRKT, FRONT DECK	1
39.	• 120228	SCREW, 5/16-18X .63 HHC GR2	4
40.	• 1498	NUT, 5/16-18 REGHEXCTRLK	4
41.	320069	DRAWBAR, DECK	1
42.	58306	ROD, DECK HITCH Z-PL 953	1
43.	8260	PIN, HAIR .091 DIA X1.66LG	1
44.	57299	BLADE, 39" STD-LIFT 19.5	2
45.	2483	WASHER,.39IDX1.25DX.07 BELLVIL	6
46.	• 39573	SCREW, 3/8-24X1.00 NYLHHCGR5	2
47.	300491	IDLER ARM BLK	1
48.	300490	BRKT, IDLER ARM	1
49.	306973	BRAKE PAD - HARD - 232AF	1
50.	41601	RIVET, OVSET .187DIA X .50LG ST	2
51.	300180	BOLT, .50 X1.88 HSH 3/8-16	1
52.	996416	WASHER, FLAT .391X1.00X.125	2
53.	45171	NUT, 3/8-16 HWDFL WHIZ-LOCK	1
54.	314186	BRACKET IDLER	1
55.	• 120228	SCREW, 5/16-18X .63 HHC	1
56.	• 1498	NUT, 5/16-18 REGHEXCTRLK	1
57.	• 120854	SCREW, 1/4-20X .63 HHC	1
58.	• 1502	NUT, 1/4-20 REGHEXCTRLK	1
59.	303247	ASSY.BLADE BRAKE 36,39,45	1
60.	303246	BRAKE ARM	1
61.	306973	BRAKE PAD	1
62.	135624	RIVET, TRSET .185DIA X .41LG ST	2
63.	• 120228	SCREW, 5/16-18X .63 HHC	1
64.	120393	WASHER, FLAT .344X .69X.065	1
65.	• 1498	NUT, 5/16-18 REGHEXCTRLK	1
66.	300316	ROD, BRAKE RELEASE 14.7 39DECK	1
67.	• 1502	NUT, 1/4-20 REGHEXCTRLK	1

• Indicates STANDARD HARDWARE ITEMS.

38" LAWN TRACTOR MODEL C3554-250

FINAL DECK ASSEMBLY

REF. 319478  
DECK ASSY. PRE-PAINT

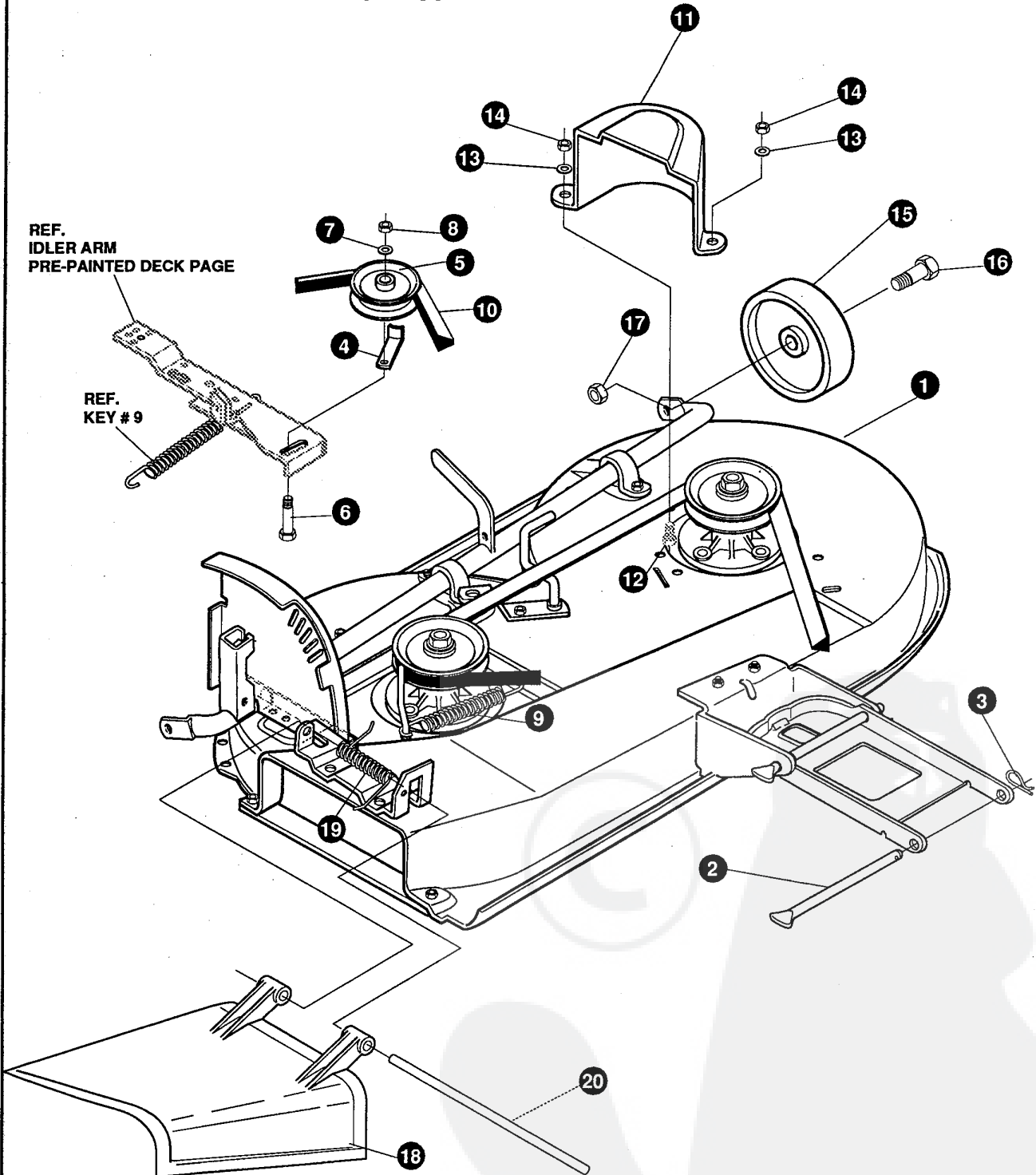

**NOTE:** ALWAYS USE ORIGINAL EQUIPMENT PARTS.  
Use of service/replacement parts other than original equipment parts may void your warranty.

ALL UNNUMBERED  
ITEMS ARE INTERCHANGABLE  
WITH OPPOSITE SIDE

319484B



### 38" LAWN TRACTOR MODEL C3554-250

key#	part#	description	qty.
1.	*	DECK, 38SDGS 2WH ASSY	1
2.	58306	ROD, DECK HITCH Z-PL 953	1
3.	8260	PIN, HAIR .091 DIA X 1.66LG	1
4.	1346	RETAINER, BELT	1
5.	310326	PULLEY, IDLER BFF 4.00 WIDE FL	1
6.	57325	BOLT, 3/8-16 X 2.00 CARR	1
7.	120382	WASHER, REGSPTLK.393X.68X.10	1
8.	• 120377	NUT, 3/8-16 REGHX	1
9.	322064	SPRING .75X8.4X.105	1
10.	300680	BELT, V 5L 77.75 KEVLAR	1
11.	302833	GUARD, BELT LH PLASTIC	1
12.	• 120228	SCREW, 5/16-18 X .63 HHC	3
13.	120393	WASHER, FLAT .344X .69X.065	3
14.	• 1498	NUT, 5/16-18 REGHEXCTRLK	3
15.	302611	WHEEL, SD 6.00OD X 1.38WD	2
16.	• 23763	BOLT, .500 X 1.390 HSSH 3/8-16	2
17.	1499	NUT, 3/8-16 REGHXCTRLK	2
18.	57818	CHUTE-36SD,39SD,45SD BLACK	1
19.	314975	SPRING TORSION CHUTE DEF.	1
20.	57317	PIVOT ROD, CHUTE	1

- STANDARD HARDWARE ITEMS
- ORDER INDIVIDUAL PARTS.

**38" LAWN TRACTOR MODEL C3554-250**

**ELECTRICAL ASSEMBLY**

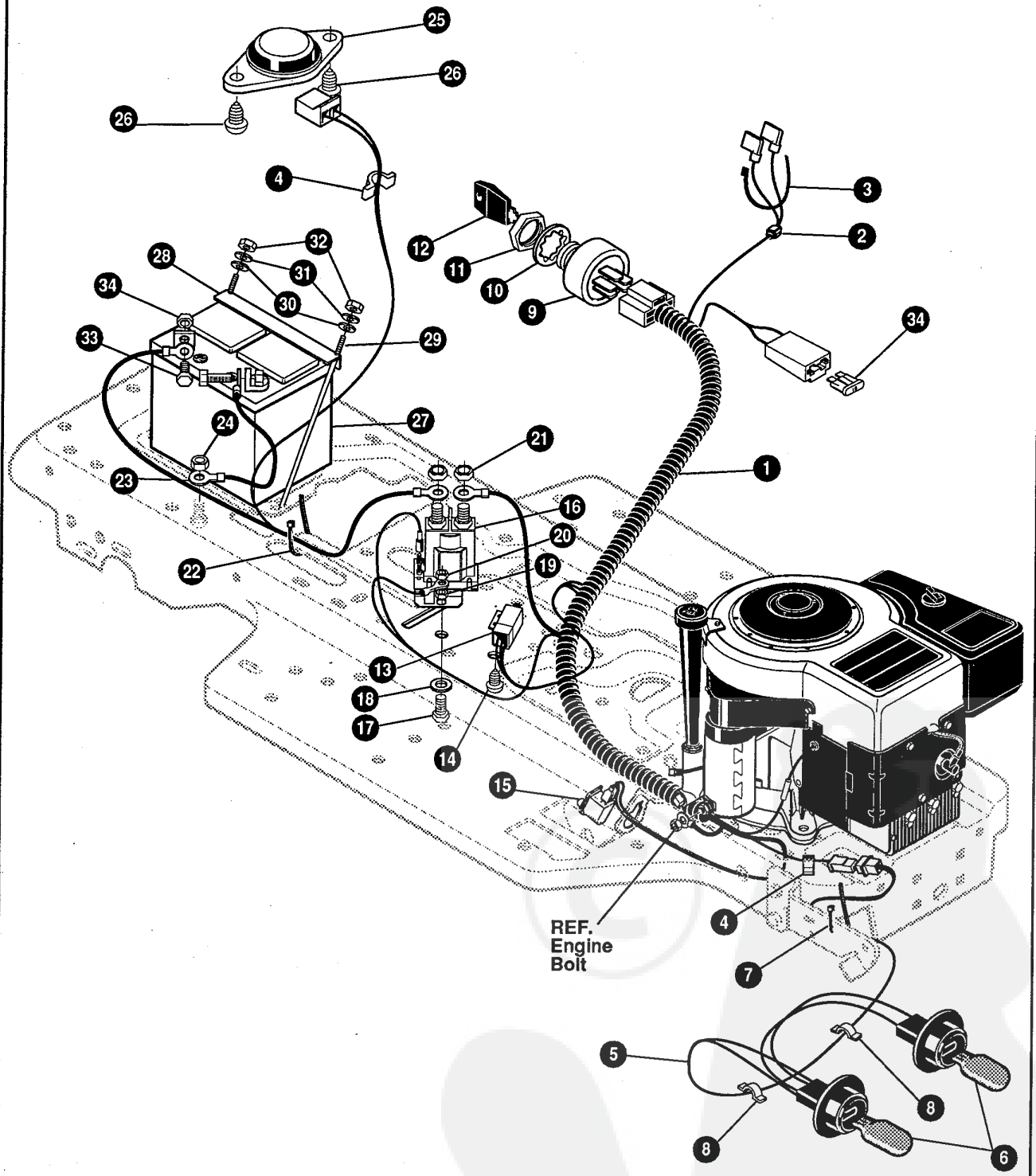

REF.  
Engine  
Bolt

**NOTE: ALWAYS USE ORIGINAL EQUIPMENT PARTS.**  
Use of service/replacement parts other than original equipment parts may void your warranty.

**ALL UNNUMBERED  
ITEMS ARE INTERCHANGABLE  
WITH OPPOSITE SIDE**

321207B

# 38" LAWN TRACTOR MODEL C3554-250

key#	part#	description	qty.
1.	322087	WIRE HARNESS SF 8-12B&S W/AMM	1
2.	322298	SPLICER	1
3.	57444	CABLE TIE	1
4.	41482	PRESS CLIP, 1.380LG .255ID	2
5.	303064	ASSY, LIGHT WIRE-1/4 TURN	1
6.	52572	BULB, HEADLAMP	2
7.	57444	TIE, CABLE BLACK NYLON 5.62	1
8.	41482	PRESS CLIP, 1.380LG .255ID	2
9.	300687	SWITCH, IGNITION & LIGHTS	1
10.	138557	WASHER, REGINTLK.640X1.1X.05	1
11.	48140	NUT, 5/8-32 HXHD IGN SWIT	1
12.	49643	2 KEYS & RING, ASSY BLANK	1
13.	57476	SWITCH, SCR MNT DP NC NO	BLK1
14.	57220	SCREW, #12 X .50 PHPNHTAP BLK	2
15.	300220	SWITCH, SNAPMNT NO .055/.116BLK	1
16.	53716	SOLENOID	1
17.	187745	SCREW, 1/4-20X .75 HXSEMMA	2
18.	1084	WASHER, FLAT .281X1.00X.063PL	1
19.	1502	NUT, 1/4-20 REGHEXCTRLK	2
20.	271172	NUT, 1/4-20 REGHEXKEPS	1
21.	271187	NUT, 5/16-24 HKEPS	2
22.	57444	TIE, CABLE BLACK NYLON 5.62L	1
23.	55511	WIRE, GROUND, 12.5"	1
24.	271184	NUT, 5/16-18 HEXKEPS	1
25.	57547	SWITCH, SEAT	1
26.	160505	SCREW, 1/4-20X .38PHPNHMAGR2	2
27.	57486	BATTERY, YUASA 12V 5-PLATE	1
28.	56360	BATTERY BRACKET	1
29.	40234	BATTERY ROD	2
30.	120392	WASHER, FLAT .281X.63X.065	2
31.	120380	WASHER, REGSPTLK.263X.49X.07	2
32.	120375	NUT, 1/4-20 REGHEX	2
33.	120854	SCREW, 1/4-20X .63 HHC	2
34.	271172	NUT, 1/4-20 REGHEXKEPS	2
35.	302031	FUSE, 15 AMP SPAPE TYPE	1

• INDICATES STANDARD HARDWARE ITEMS  
 ••Spade type fuse included with the wire harness.

## SCHEMATIC DRAWING:

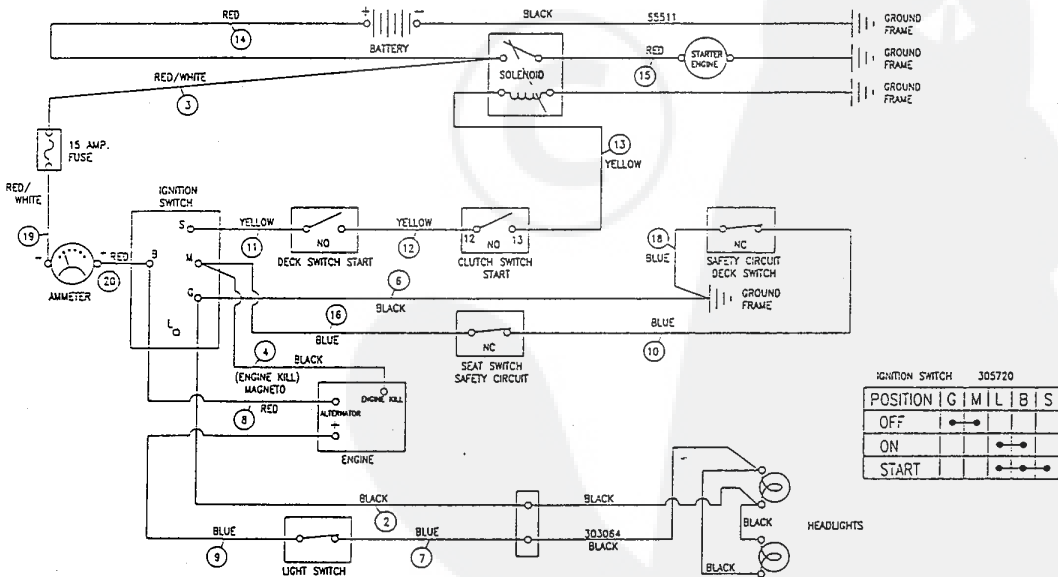

38" LAWN TRACTOR MODEL C3554-250

DECALS

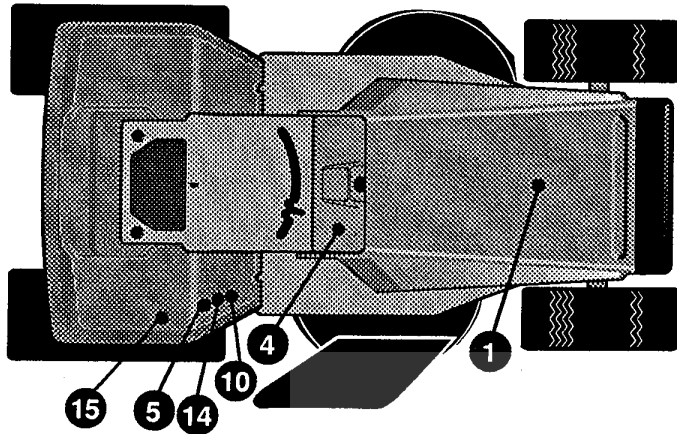
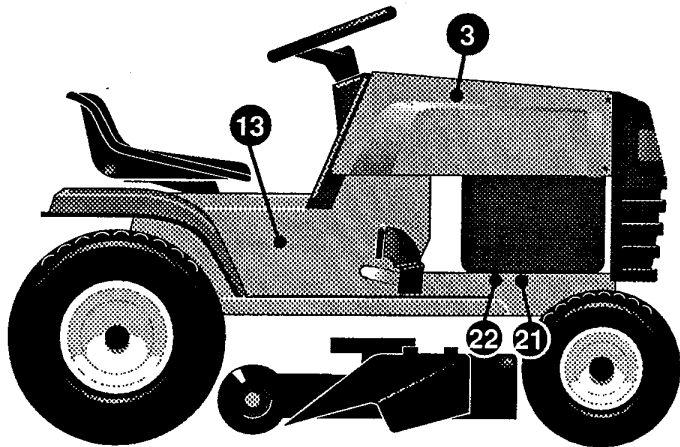
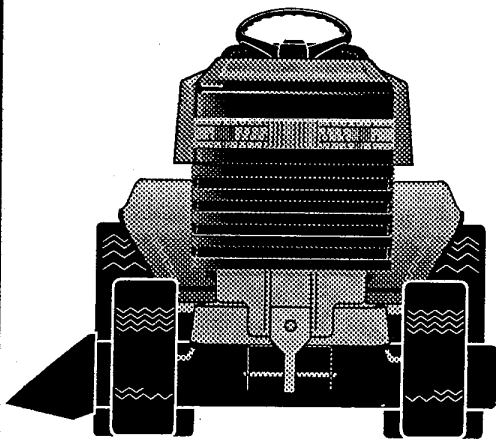

CONSOLE DETAIL

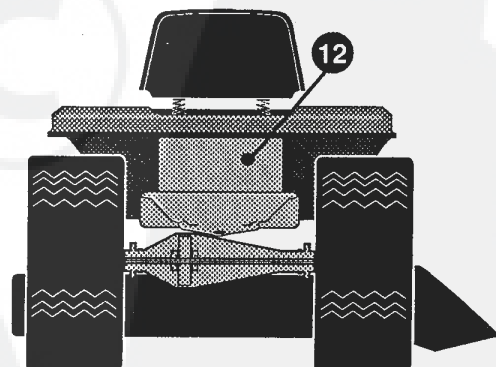
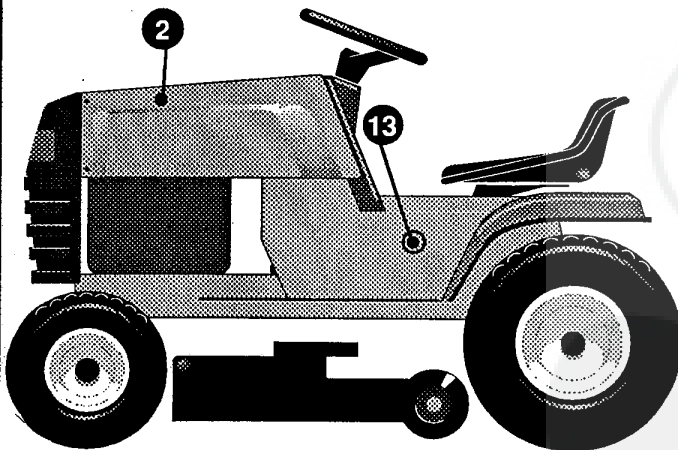
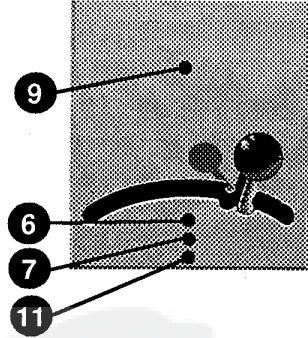

324112A

### 38" LAWN TRACTOR MODEL C3554-250

key#	part#	description	qty.
1	55832	PAD FOAM TOP HAND	1
2	55833	PAD FOAM SIDE LH	1
3	55834	PAD FOAM SIDE RH	1
4	320686	DECAL, DASH	1
5	68902	DECAL, WARNING, FRENCH/GERMAN	1
6	69524	DECAL, INSTRUCT CONSOLE TOP GER	1
7	69525	DECAL, INSTRUCT CONSOLE TOP FR	1
8		REFERENCE ONLY	1
9	301104	DECAL, CONSOLE TOP SHIFT 5-SP	1
10	305770	DECAL, CAUTION TRIANGLE EUROPE	1
11	307383	DECAL, INSTR. CONSOLE TOP ENGL	1
12	310436	DECAL, FRENCH SAFETY CERT.	1
13	314208	NAMEPLATE, 12/38	2
14	310553	DECAL, DANGER ENGLISH	1
15	68901	DECAL, BLADE HEIGHT ADJ. EUROPE	1
16		REFERENCE ONLY	1
17	67667	DECAL, CHECK OIL LEVEL	1
18	68903	DECAL, BRAKE/CLUTCH EUROPE	1

**38" LAWN TRACTOR MODEL C3554-250**

**CUSTOMER ASSEMBLY**

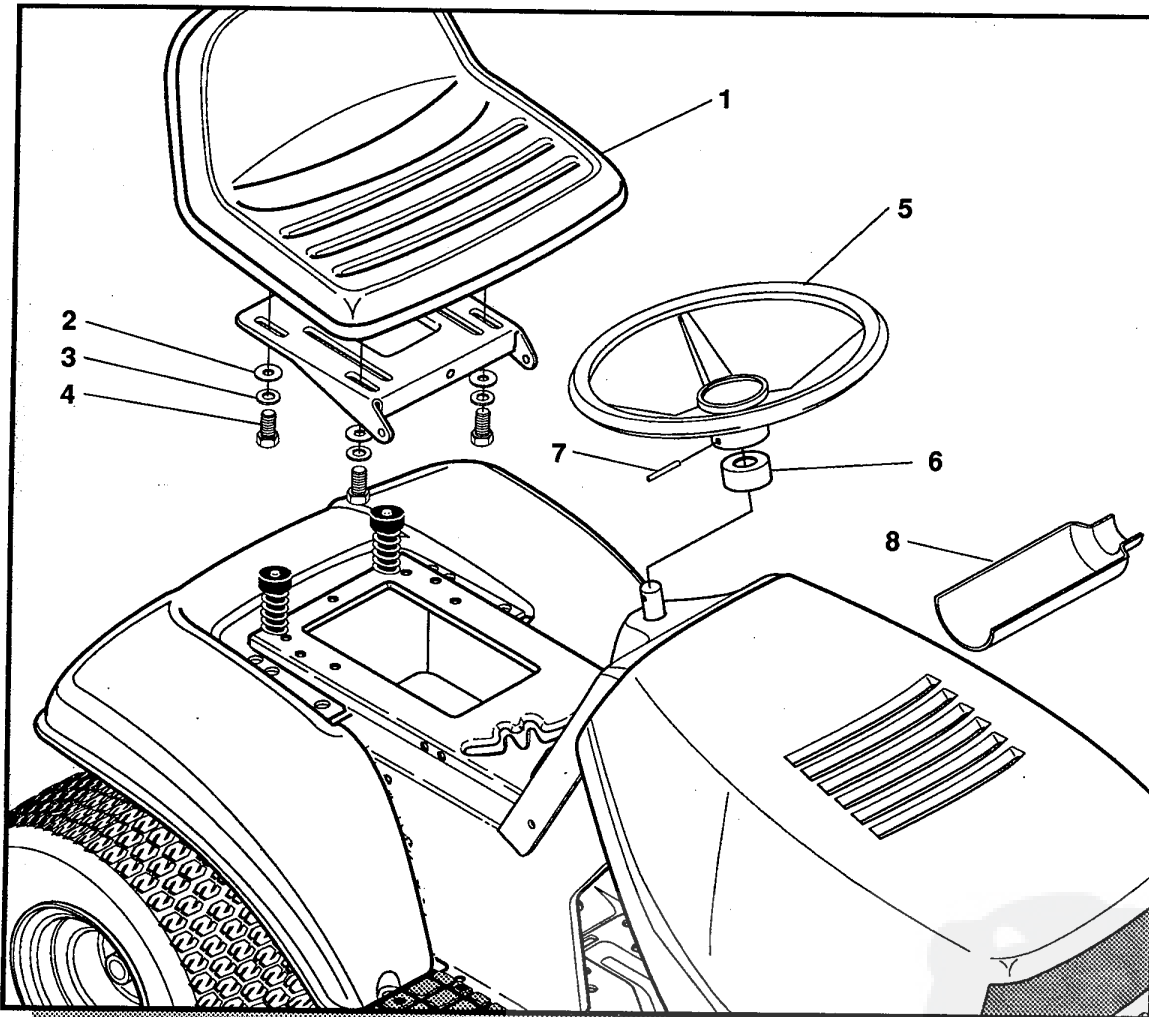

**CUSTOMER ASSEMBLY VIEW**

**315134 PARTS BAG ASSY QTY1**

key#	part#	decription	qty
1	57452	SEAT MV350	1
2	120393	WASHER,FLAT .344X.69X.065	4
3	120638	WASHER, HVSP LTK .328X.60X.109	4
4	122007	SCREW, 5/16-18X.75 HHC	4
5	301251	STEERING WHEEL	1
6	323758	STEERING, SLEEVE	1
7	456378	ROLL PIN .250DIA X 2.0LG	1
8	54873	OIL TROUGH	1

316235B

# TREAD PATTERNS

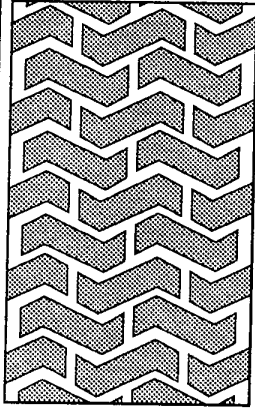

**"A"**

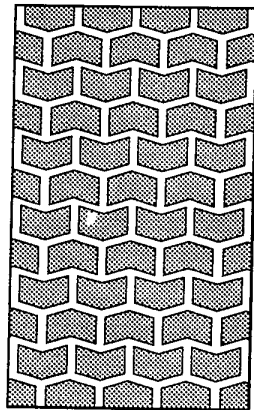

**"B"**

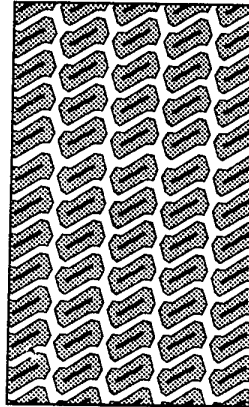

**"C"**

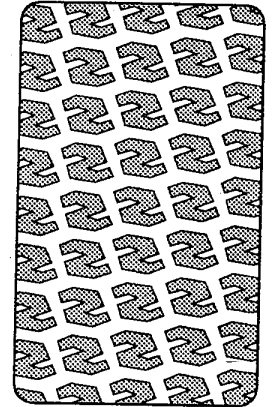

**"D"**

TIRE SIZE	"A"	"B"	"C"	"D"
11 X 4.00 - 5	42295	319679		
13 X 5.00 - 6	41060	319680		
15 X 6.00 - 6	39830	316702	301140	313952
16 X 6.50 - 8	41081	319682		314539
18 X 8.50 - 8	319683	317400		
18 X 9.50 - 8	41106	316701		313950
20 X 8.00 - 8	319685	319684	57164	314584
20 X 10.00 - 8	58276	319686		313654
20 X 10.00 - 10	55893	319687		
23 X 9.50 - 12	53655	319690	319689	314370

## ACCESSORIES

Contact the dealer where your tractor was purchased for the available accessories. If you are unable to contact the dealer, write to the address on the front cover of this manual.

### Rear Engine Rider

Model	Description
5708-16	Bagger - Fits 32" Side Discharge
5708-17	Bagger - Fits 36" Side Discharge
5709-02	Front Weight Box - holds 35 lbs.
5648-16	Lawn Sweeper w/dump Release

### Lawn Tractor

Model	Description
5708-22	Bagger - Fits 30" Top Discharge
5708-13	Bagger - Fits 36", 38", 39' & 45" Side Discharge
5708-14	Bagger - Fits 40", 42", 43" & 46" Side Discharge
5661-06	42" Snowblade
5661-08	48" Snowblade
5592-00	Tire Chains - 18" x 6.50"
5585-00	Tire Chains - 18" x 9.50" & 20" x 8"
5672-01	Wheel Weights - Front - 1 pr. w/mtg. hdw. - Fits 15" tires
5673-02	Wheel Weights - Rear - 1 pr. w/mtg. hdw. - Fits 18" & 20" tires
5709-03	Front Weights - Fits 30" & 32" Side Discharge
5648-16	Lawn Sweeper w/dump Release
5705-06	42" Two-Stage Snowblower

### Garden Tractor - Light Ground Engaging

Model	Description
5708-13	Bagger - Fits 36", 38", 39", & 45" Side Discharge
5708-14	Bagger - Fits 40", 42", 43" & 46" Side Discharge"
5661-06	42" Snowblade
5672-01	Wheel Weights - Front 1 pr. w/mtg. hdw. - Fits 15" tires
5673-02	Wheel Weights - Rear - 1 pr. w/mtg. hdw. - Fits 18" & 20" tires
5648-16	Lawn Sweeper w/dump Release
5667-02	Sleeve Hitch - w/lift bar
5668-01	Adaptor (sleeve hitch) for use w/23" tires
5706-00	Tire Chains - 20" x 10"
5671-00	Tire Chains - 23" x 9.50"
5672-02	Wheel Weights - Front - 1 pr. w/mtg. hdw. Fits 16" tires
5673-00	Wheel Weights - Rear - 1 pr. w/mtg. hdw. Fits 23" tires
5674-01*	10" One Bottom Moldboard Plow
5675-01*	Cultivator - 7 row - Adj. 6" - 42" width
5676-01*	Disc Harrow - 8" & 11" disc - Adj. width & disc angle
5677-02*	Tiller - 5 H.P. Self-Powered - 28" width
5705-06	42" Two-Stage Snowblower
5661-08	48" Snowblade

### Euro Four Wheel Steer

Model	Description
5708-14	Bagger - Fits 40", 42", 43" & 46" Side Discharge
5705-05	42" One-Stage Snowblower
5661-07	48" Snowblade
5709-04	Rear Weight Box
5648-16	Lawn Sweeper w/dump Release
5706-00	Tire Chains 20" x 10"
5671-00	Tire Chains 23" x 9.50"
5672-02	Wheel Weights - Front - 1 pr. w/mtg. hdw. Fits 16" tires
5673-00	Wheel Weights - Rear - 1 pr. w/mtg. hdw. Fits 23" tires
5672-01	Wheel Weights - Front - 1 pr. w/mtg. hdw. Fits 15" tires
5673-02	Wheel Weights - Rear - 1 pr. w/mtg. hdw. Fits 18" & 20" tires

### Euro Two Wheel Steer Garden Tractor

Model	Description
5667-04	Sleeve Hitch - w/lift bar Fits 46"
5674-01*	10" One Bottom Moldboard Plow
5675-01*	Cultivator - 7 row - Adj. 6" - 42" width
5676-01*	Disc Harrow 8" & 11" Disc. Adj. width & disc angle
5677-02*	Tiller 5 H.P. Self-Powered - 28" width
5648-16	Lawn Sweeper w/dump Release

\*Requires a sleeve hitch