

# REPAIR PARTS MANUAL

## 30" - 10 H.P. LAWN TRACTOR

### MODEL C3554-260

#### ONE YEAR LIMITED WARRANTY

For one (1) year from date of purchase by the first consumer for residential use (thirty (30) days commercial use), NOMA Outdoor Products Incorporated warrants that it will replace free of charge, including labor, any original part of any NOMA Outdoor Products Incorporated product found to be defective by any authorized Service Dealer or the factory, except the battery which is warranted for ninety (90) days from date of purchase.

This warranty does not cover engine, transmission, transaxle or differential (these items are covered by their manufacturer's own warranty). This warranty does not cover parts that have failed due to normal wear or parts that have failed subject to misuse or abuse. Transportation of the unit or part to and from an authorized Service Dealer or factory is the responsibility of the owner.

A step by step explanation as to what procedure should be followed for this warranty is:

1. If a part becomes defective, contact the store where the unit was purchased for the name and address of the authorized Service Dealer nearest to you.
2. If you cannot locate an authorized Service Dealer, write Service Department of NOMA Outdoor Products Incorporated for the name and address of the authorized Service Dealer in your area or call the Service Department at 1-901-422-1690.
3. Return the defective product, along with proof of purchase to such authorized Service Dealer for replacement of any defective part where covered by this warranty.

There is no other express warranty. Implied warranties, including those of merchantability and fitness for a particular purpose are limited to one (1) year from date of purchase. Liability for incidental or consequential damages are excluded.

Some states do not allow limitations on how long an implied warranty lasts, so the above limitation may not apply to you. Some states do not allow the exclusion of incidental or consequential damages, so the above exclusion may not apply to you. This warranty gives you specific legal rights, and you may have other rights which vary from state to state.

**NOMA Outdoor Products Incorporated**

**Caller 8000**

**Jackson, TN 38308-8000**

#### UNIT PARTS AND SERVICE

Fill in and mail the registration card packed with the unit. For service other than covered in this manual, contact an authorized service dealer. A nationwide parts and service organization has been established to provide locally available parts and service. When ordering repair parts, always give the following information: 1. The Part Name; 2. The Part Number; 3. The Quantity desired; 4. The Full (eight digit) Model Number of the unit. The model number will be found on a plate attached to the unit.



**Look for this symbol. It means - ATTENTION! BECOME ALERT! A HAZARD TO OPERATOR, BYSTANDER, PROPERTY OR EQUIPMENT MAY EXIST.**

**NOMA Outdoor Products Incorporated**

**Caller 8000**

**Jackson, TN 38308-8000**

Part No. 323560A / D

1/92



## SAFETY RULES

THESE INSTRUCTIONS ARE FOR YOUR PROTECTION. PLEASE READ THEM CAREFULLY.



### IMPORTANT

THIS CUTTING MACHINE IS CAPABLE OF AMPUTATING HANDS AND FEET AND THROWING OBJECTS. FAILURE TO OBSERVE THE FOLLOWING SAFETY INSTRUCTIONS COULD RESULT IN SERIOUS INJURY OR DEATH.

#### I. GENERAL OPERATION:

- Know controls and how to stop quickly.
- Read, understand, and follow all instructions in the manual and on the machine before starting.
- Only allow responsible adults, who are familiar with instructions, to operate the machine.
- Wear safety glasses or eye shields when assembling or operating the machine.
- Do not operate machine when barefooted. Always wear substantial footwear, preferably steel-toed shoes.
- Do not wear loose fitting clothing that could get caught in moving parts.
- Clear the area of objects such as rocks, toys, wire, etc., which could be picked up and thrown by the blade(s).
- Be sure the area is clear of other people before mowing. Stop machine if anyone enters the area.
- Never carry passengers.
- Do not mow in reverse unless absolutely necessary. Always look down and behind before and while backing.
- Be aware of the mower discharge direction and do not point it at anyone. Do not operate the mower without either the entire grass catcher or the guard in place.
- Slow down before turning.
- Never leave a running machine unattended. Always turn off blades, set parking brake, stop engine, and remove keys before dismounting.
- Turn off blade(s) when not mowing.
- Stop engine before removing grass catcher or unclogging chute.
- Mow only in daylight or good artificial light.
- Do not operate the machine while under the influence of alcohol or drugs.
- Watch for traffic when operating near or crossing roadways.
- Use care when mowing around a fixed object to prevent the blade(s) from striking it. Never deliberately run over any foreign object.
- Use extra care when loading or unloading the machine into a trailer or truck.
- Use care when pulling loads or using heavy equipment.
  - a. Use only approved drawbar hitch points.
  - b. Limit loads to those that you can safely control.
  - c. Do not turn sharply. Use care when backing.
  - d. Use counterweight(s), wheel weight or tire chains when suggested in attachment(s) instructions.

#### II. SLOPE OPERATION:

Slopes are a major factor related to loss-of-control and tip-over accidents, which can result in severe injury or death. *All slopes require extra caution.* If you cannot back up the slope or if you feel uneasy on it, do not mow it.

##### DO

- Mow up and down slopes, not across.
- Remove obstacles such as rocks, tree limbs, etc.
- Watch for holes, ruts, or bumps. Uneven terrain could overturn the machine. *Tall grass can hide obstacles.*
- Use slow speed. Choose a low gear so that you will not have to stop or shift while on the slope.
- Follow the manufacturer's recommendations for wheel weights or counterweights to improve stability.
- Use extra care with grass catchers or other attachments. These can change the stability of the machine.
- Keep all movement on the slopes *slow and gradual*. Do not make sudden changes in speed or direction.
- Avoid starting or stopping on a slope. If tires lose traction, turn off the blade(s) and proceed slowly *straight* down the slope.

##### DO NOT

- Do not turn on slopes unless necessary, and then slowly and gradually downhill, if possible.
- Do not mow near drop-offs, ditches or embankments. The

mower could suddenly turn over if a wheel is over the edge of a cliff or ditch, or if an edge caves in.

- Do not mow on wet grass. Reduced traction could cause sliding.
- Do not try to stabilize the machine by putting your foot on the ground.
- Do not use grass catcher on steep slopes.

#### III. CHILDREN:

Tragic accidents can occur if the operator is not alert to the presence of children. Children are often attracted to the machine and the mowing activity. *Never* assume that children will remain where you last saw them.

- Keep children out of the mowing area and under the watchful care of another responsible adult.
- Be alert and turn machine off if children enter the area.
- Before and when backing, look behind and *down* for small children.
- Never carry children. They may fall off and be seriously injured or interfere with safe machine operation.
- Never allow children to operate the machine.
- Use extra care when approaching blind corners, shrubs, trees, or other objects that may obscure vision.

#### IV. SERVICE:

- Use extra care in handling gasoline and other fuels. They are flammable and vapors are explosive.
  - a. Use only an approved container.
  - b. Never remove gas cap or add fuel with the engine running. Allow engine to cool before refueling. Do not smoke.
  - c. Never refuel the machine indoors.
  - d. Never store the machine or fuel container inside where there is an open flame, such as in a water heater.
- Check fuel supply before each use allowing space for expansion as the heat of the engine and/or sun can cause gasoline to expand and overflow the tank.
- Use extra care when handling battery acid. Acid contact with skin may cause severe burns. Eye contact may cause blindness.
- Use extra care when servicing the battery. Explosive gas is produced in the battery. Do not service the battery while smoking or near an open spark or flame. This may cause the battery to explode causing serious injury.
- Never run a machine inside a closed area. Exhaust fumes contain CARBON MONOXIDE, an ODORLESS and DEADLY GAS.
- Keep nuts and bolts, especially blade attachment bolts, tight and keep equipment in good condition.
- Never tamper with safety devices. Check their operation regularly.
- Do not change the engine governor settings or overspeed engine.
- Reduce fire hazards. Keep machine free of grass, leaves, or other debris build-up. Clean up oil or fuel spillage. Allow machine to cool before storing.
- Stop and inspect the equipment if you strike an object. Repair, if necessary, before restarting.
- Never make adjustments or repairs with the engine running.
- Grass catcher components are subject to wear, damage, and deterioration, which could expose moving parts or allow objects to be thrown. Frequently check components and replace with manufacturer's recommended parts, when necessary.
- Mower blade(s) are sharp and can cut. Wrap the blade(s) or wear gloves, and use extra caution when servicing them.
- Check brake operation frequently. Adjust and service as required.



LOOK FOR THIS SYMBOL TO POINT OUT IMPORTANT SAFETY PRECAUTIONS. IT MEANS--ATTENTION!!! BECOME ALERT!!! YOUR SAFETY IS INVOLVED.

## OWNER'S INFORMATION

Record the following information about your unit so that you will be able to provide it in case of loss or theft.

MODEL NUMBER:  -  (Enter complete 8 digit number from model plate on unit)  
PURCHASE DATE: \_\_\_ / \_\_\_ / \_\_\_ CODE NO.: \_\_\_\_\_ SERIAL NO.: \_\_\_\_\_  
DEALER'S NAME AND ADDRESS: \_\_\_\_\_  
CITY: \_\_\_\_\_ STATE: \_\_\_\_\_ TELEPHONE: \_\_\_\_\_

### CONTENTS OF SHIPPING CARTON

- 1 - Lawn Tractor with 30 inch Mower Deck
- 1 - Operator's Manual
- 1 - Repair Parts Manual
- 1 - Engine Manual
- 1 - Steering Wheel (see Note)
- 1 - Seat (see Note)
- 1 - Bag of Assembly Parts Containing (see Note):
  - 1 - Oil Drain Trough
  - 4 - 5/16 x 3/4 inch Hex Head Screws
  - 4 - 5/16 inch Split Lockwashers
  - 4 - .11/32 inch Flatwashers
  - 1 - Roll Pin
  - 1 - Steering, Sleeve

**NOTE:** Refer to page 22 (Customer Assembly Parts) for more detailed description.

### TOOLS REQUIRED FOR ASSEMBLY

- 2 - 7/16 inch Wrenches (or adjustable wrench)
- 1 - 1/2 inch Wrench (or adjustable wrench)
- 1 - Small Phillips Screwdriver with a 1/4 inch shank
- 1 - Hammer

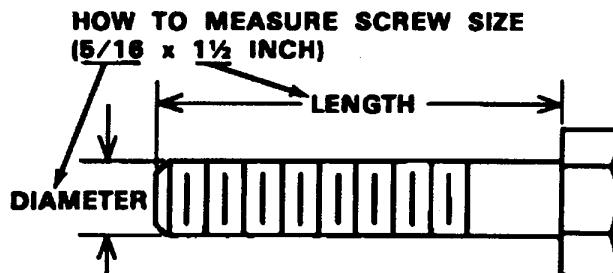

## DANGER



This lawn tractor can be dangerous if carelessly used.

Read your Operator's Manual thoroughly before operating your lawn tractor.

Always wear safety glasses or eye shields while assembling or operating your lawn tractor.

**DO NOT** carry passengers at any time.

Keep your hands, feet, hair and loose clothing away from the discharge area, the underside of the mower deck or any moving parts while the engine is running.

**DO NOT** allow children or young teenagers to operate or be near your lawn tractor while it is operating.

ALWAYS GIVE THE FOLLOWING INFORMATION WHEN ORDERING REPAIR PARTS:

1. The PART NUMBER; 2. The PART NAME; 3. QUANTITY DESIRED; 4. The MODEL NUMBER (As shown on Model Plate).

SEND PART ORDERS AS PER INSTRUCTIONS ON THE FRONT PAGE.

**DO NOT USE KEY NUMBERS WHEN ORDERING REPAIR PARTS, ALWAYS USE PART NUMBERS.**

All replacement parts will be supplied in current production colors or in a neutral color.

A handling fee is applicable to small parts orders.

YOUR UNIT IS RIGHT HAND (RH) OR LEFT HAND(LH) AS YOU STAND BEHIND IT.

# 30" LAWN TRACTOR MODEL C3554-260

## CHASSIS & HOOD ASSEMBLY

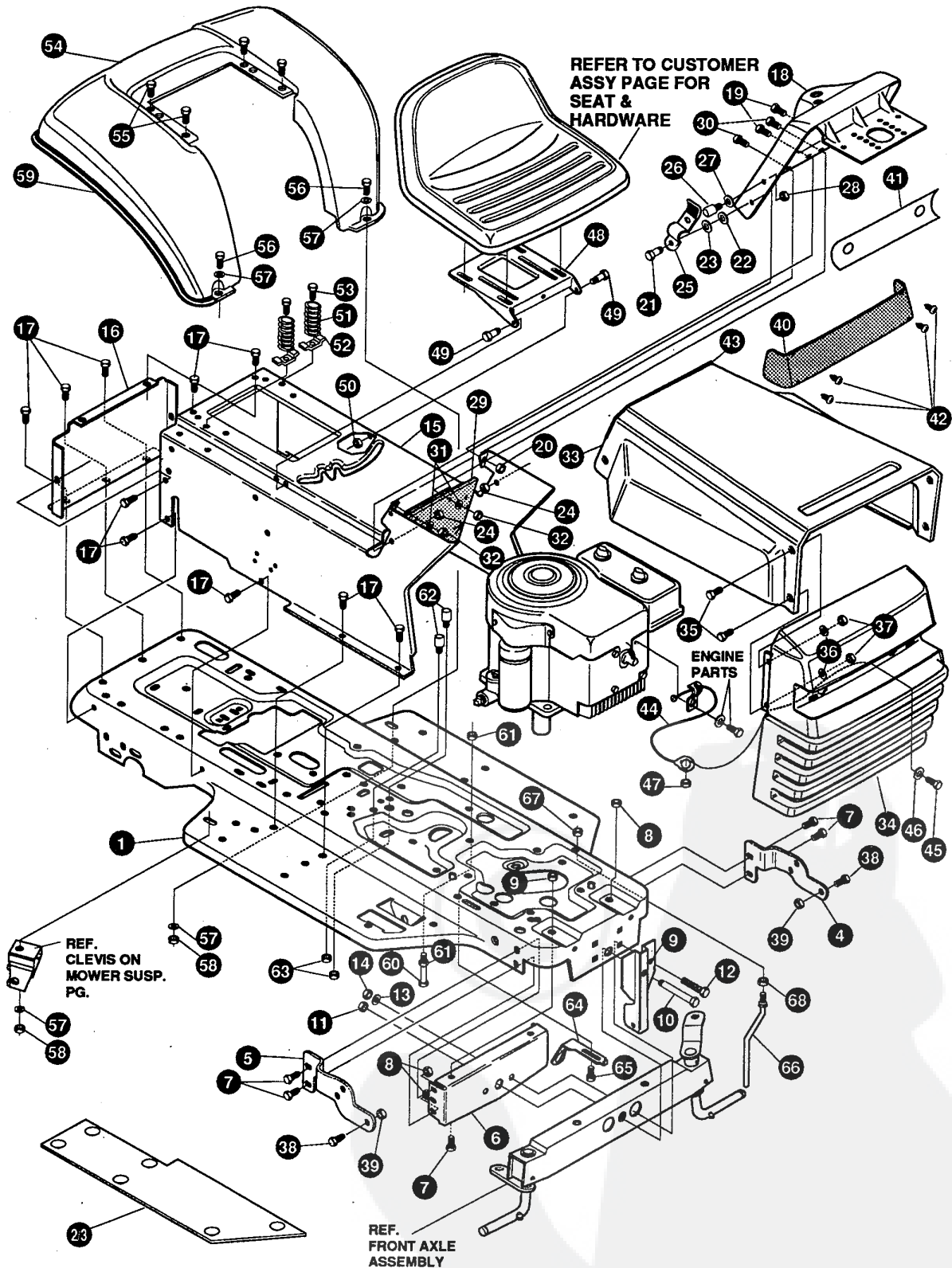

**NOTE: ALWAYS USE ORIGINAL EQUIPMENT PARTS.** Use of service/replacement parts other than original equipment parts may void your warranty.

**ALL UNNUMBERED ITEMS ARE INTERCHANGABLE WITH OPPOSITE SIDE**

323428B

### 30" LAWN TRACTOR MODEL C3554-260

Key#	Part#	Description	Qty.
1	314883-860	FRAME, MAIN SF RIDER	1
2	302917	FOOTPAD, LH	1
3	302916	FOOTPAD, RH	1
4	314579-853	BRACKET, GRILLE L.H.-853	1
5	314578-853	BRACKET, GRILLE R.H.-853	1
6	56362-853	BRKT, SUPT FRT AXLE-853	1
7	• 56030	SCREW, 5/16-18X.75WDFLLK	6
8	• 55273	NUT, 5/16-18 HXWDFLLK	6
9	321136-853	HANGER BRKT	1
10	50720	BOLT, .625X2.875 SPSH 1/2-20	1
11	• 274654	NUT, 1/2-20 REGHXCTRLK	1
12	• 122201	SCREW, 3/8-16X2.75 HHC	4
13	2483	WASHER, .39IDX1.25DX.07 BELLVIL	4
14	• 1499	NUT, 3/8-16 REGHXCTRLK	4
15	314491-860	CONSOLE, SF DYNA STYLE TOPSH	1
16	56235-860	CONSOLE, REAR COVER	1
17	• 995346	SCREW, 1/4-20X .50 WAHTAP	15
18	320466-860	DASH, SF NOMA DYNA STYLING	1
19	• 995338	SCREW, 1/4-20X .63 HHWATAP	2
20	50352	NUT, 1/4-20 WDFLLK TOP LOCK	2
21	8482	BOLT, .375X .156 HSH 5/16-18	2
22	• 120394	WASHER, FLAT .406X .81X.065	2
23	• 120393	WASHER, FLAT .344X .69X.065	2
24	• 1498	NUT, 5/16-18 REGHEXCTRLK	2
25	57159	LATCH, .94WDX.047 ASSY HOOD	2
26	53446	PIN, 5/16-18 HOOD LATCH	2
27	• 138538	WASHER, REGINTLK.320X.61X.03	2
28	• 45174	NUT, 5/16-18 HEXWDFLLK WHIZ	2
29	312306	BAFFLE, CONSOLE SOUND EXPORT	1
30	• 995338	SCREW, 1/4-20X .63 HHWATAP	2
31	• 120393	WASHER, FLAT .344X .69X.065	2
32	• 1502	NUT, 1/4-20 REGHEXCTRLK	2
33	314538-860	HOOD	1
34	314476	GRILLE, DYNA-PRO	1
35	• 274672	SCREW, 1/4-20X .63 WAHHC	4
36	• 120392	WASHER, FLAT .281X .63X.065	4
37	• 1502	NUT, 1/4-20 REGHEXCTRLK	4
38	36149	BOLT, .375X .500 HSH 5/16-18	2
39	• 1498	NUT, 5/16-18 REGHEXCTRLK	2
40	302333	LENS, HEADLAMP	1
41	314948	FOIL, LENS DYNA-PRO REFLECTOR	1
42	• 57796	SCREW, #6 X .50 PLASTITE	4
43	47453	EDGING, WIDE BLK	25"
44	311094	LANYARD, HOOD	1
45	121887	SCREW, 1/4-20 X .75 HHC	1
46	120392	FLATWASHER, .281 X .63 X .065	1
47	1502	LOCKNUT, 1/4-20	1
48	58367-853	PLATE, SEAT F-5 SF & LF	1
49	20507	BOLT, .437X .156 HSH 5/16-18	2
50	• 1498	NUT, 5/16-18 REGHEXCTRLK	2
51	56220	SPRING, 1.43X2.38X.162 COM SEAT	2
52	300284-953	CLAMP, SPRING 1.17"ID	2
53	• 995346	SCREW, 1/4-20X .50 WAHTAP	2
54	321157-860	FENDER	2
55	• 995346	SCREW, 1/4-20X .50 WAHTAP	4
56	• 122027	SCREW, 5/16-18X1.25 HHC	2
57	• 446363	WASHER, FLAT .375X .88X.082	4
58	• 1498	NUT, 5/16-18 REGHEXCTRLK	2
59	• 55021	TRIM	1
60	49930	SCREW, 3/8-16X6.50 HHC	1
61	• 1499	NUT, 5/16-18 REGHEXCTRLK	2
62	• 53446	PIN, 5/16-18	2
63	• 271184	NUT, 5/16-18 HEX KEPS	2
64	302610-853	BRACKET, SWITCH MOUNT	1
65	• 995346	SCREW, 1/4-20X .50 WAHTAP	1
66	50653	GUIDE, BELT	1
67	• 41529	NUT, 3/8-16 HXCTRLKJAM	1
68	• 271190	NUT, 3/8-16 HEXKEPS	1
69	323310	OPERATOR'S MANUAL ENGLISH	1
70	324560	PARTS MANUAL ENGLISH	1
71	323312	OPERATOR'S MANUAL FRENCH	1
72	323313	OPERATOR'S MANUAL GERMAN	1
73	323000	GRASS CATCHER MANUAL ENGLISH	1
74	323207	GRASS CATCHER MANUAL GERMAN	1
75	323208	GRASS CATCHER MANUAL FRENCH	1

• INDICATES STANDARD HARDWARE ITEMS.

# 30" LAWN TRACTOR MODEL C3554-260

## MOWER SUSPENSION ASSEMBLY

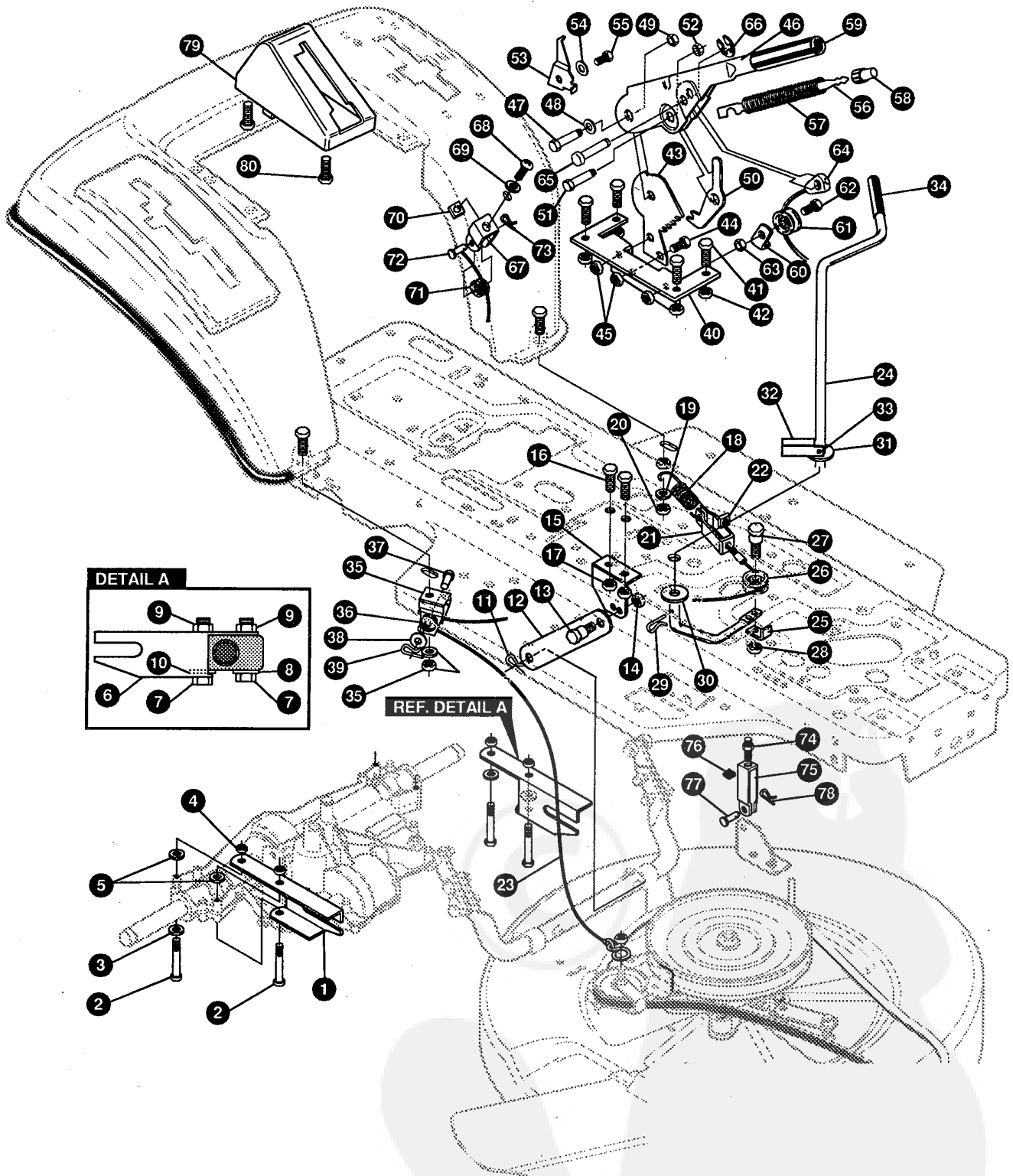

**NOTE:** ALWAYS USE ORIGINAL EQUIPMENT PARTS. Use of service/replacement parts other than original equipment parts may void your warranty.

**ALL UNNUMBERED ITEMS ARE INTERCHANGABLE WITH OPPOSITE SIDE**

321324A

### 30" LAWN TRACTOR MODEL C3554-260

Key#	Part#	Description	Qty.
1	313426	BRACKET REAR SUPPORT, RH	1
2	122083	SCREW, 5/16-18X2.75 HHC GR2	2
3	120393	WASHER, FLAT .344X.69X.065	1
4	1498	NUT, 5/16-18 REGHEXCTRLK	2
5	314702	SPACER SLEEVE, .344X1.00X.500	2
6	313425	BRACKET, REAR SUPPORT, LH	1
7	180089	SCREW, 5/16-18X2.25 HHC	2
8	120393	WASHER, FLAT .344X.69X.065	1
9	1498	NUT, 5/16-18 REGHEXCTRLK	2
10	314702	SPACER, SLEEVE .344X1.00X.500	1
11	56180	PIN, HAIR .091 DIA X1.62 LG	1
12	314047	BRACKET, LIFT BAR	1
13	313560	BOLT, .500X.225 HSH 5/16-18	1
14	1498	NUT, 5/16-18 REGHEXCTRLK	1
15	320605	BRACKET, LIFT BAR	1
16	180077	SCREW, 5/16-18X.75 HHC	2
17	1498	NUT, 5/16-18 REGHEXCTRLK	2
18	300473	SPRING, TENSION, 7.52LG+17LB/IN	1
19	418924	WASHER, FLAT .344 X 1.13 X .062	1
20	1498	NUT, 5/16-18 REGHEXCTRLK	1
21	300703-953	CLEVIS, LIFT CABLE	1
22	120372	NUT, 1/4-20 REGSQ	1
23	322261	CABLE, CLUTCH	1
24	314877	LEVER, CLUTCH	1
25	52456-953	BRACKET, CABLE RETAINER	1
26	48306	PULLEY	1
27	58336	BOLT, .375X.375 HSH	1
28	1502	NUT, 1/4-20 REGHEXCTRLK	1
29	8260	PIN, HAIR .091 DIA1.66	1
30	996425	WASHER, FLAT .515X.88X.064	1
31	22265	WASHER, FLAT .515X1.38X.119	1
32	12633-953	LF STOP, PTO ENGAGEMENT	1
33	455481	PIN, SPRING .187DIA X1.00 LG HVPL	1
34	46478	GRIP, HAND	1
35	321295-853	CLEVIS, PTO	1
36	48306	PULLEY	1
37	300317	PIN, CLEVIS	1
38	996416	WASHER, FLAT .391X1.00X.125	1
39	8260	PIN, HAIR .091DIA X1.66 LG	1
40	58333	BRACKET, HEIGHT ADJUST	1
41	180077	SCREW, 5/16-18X.75 HHC	4
42	1498	NUT, 5/16-18 REGHEXCTRLK	4
43	301238	QUADRANT, HEIGHT ADJUST	1
44	180077	SCREW, 5/16-18X.75 HHC	2
45	1498	NUT, 5/16-18 REGHEXCTRLK	2
46	322292-853	HANDLE, LIFT HEIGHT ADJUST	1
47	300171	BOLT, .500X.270HSH 5/16-18	1
48	996418	WASHER, FLAT .506X.75X.024	1
49	44108	NUT, 5/16-18 HWDPLCTRLK	1
50	301239	PAWL, HEIGHT ADJUST	1
51	300171	BOLT, .500X.270 HSH 5/16-18	1
52	44108	NUT, 5/16-18 HWDPLCTRLK	1
53	300782-953	POINTER, HEIGHT ADJUST	1
54	138479	WASHER, EXLK .195X.41X.03	1
55	35287	SCREW, #8-32X.38 HHWATAPGR2	1
56	303027	ROD, ACTUATOR SHORT	1
57	58326	SPRING, HEIGHT ADJUST	1
58	58325	KNOB, HEIGHT PUSH BUTTON	1
59	58329	GRIP, .750 OD W/HOLE BLACK	1
60	58335-953	BRACKET, CABLE RETAINER	1
61	39298	PULLEY, NYLON	1
62	58336	BOLT, .375X.375 HSH 1/4-20	1
63	1502	NUT, 1/4-20 REGHEXCTRLK	1
64	321430	CABLE, LIFT 20.50	1
65	300310	PIN, CLEVIS	1
66	300311	RING, RET E	1
67	300298-953	CLEVIS	1
68	439455	SCREW, 5/16-18X.56PHPNMA	1
69	301551	WASHER, .344ID X1.50DX.09	1
70	120373	NUT, 5/16-18 SQ	1
71	39298	PULLEY, NYLON	1
72	300317	PIN, CLEVIS .38 DIA.X.81	1
73	8260	PIN, HAIR	1
74	120375	NUT, 1/4-20 REGHEX	1
75	300703-953	CLEVIS, LIFT CABLE	1
76	120372	NUT, 1/4-20 REGSQ	1
77	39522	PIN, CLEVIS .312X.812	1
78	121222	PIN, COTTER	1
79	300335	LIFT COVER-39" F5	1
80	300340	SCREW, #10 X .75 HH PLAST	3

# 30" LAWN TRACTOR MODEL C3554-260

## STEERING ASSEMBLY

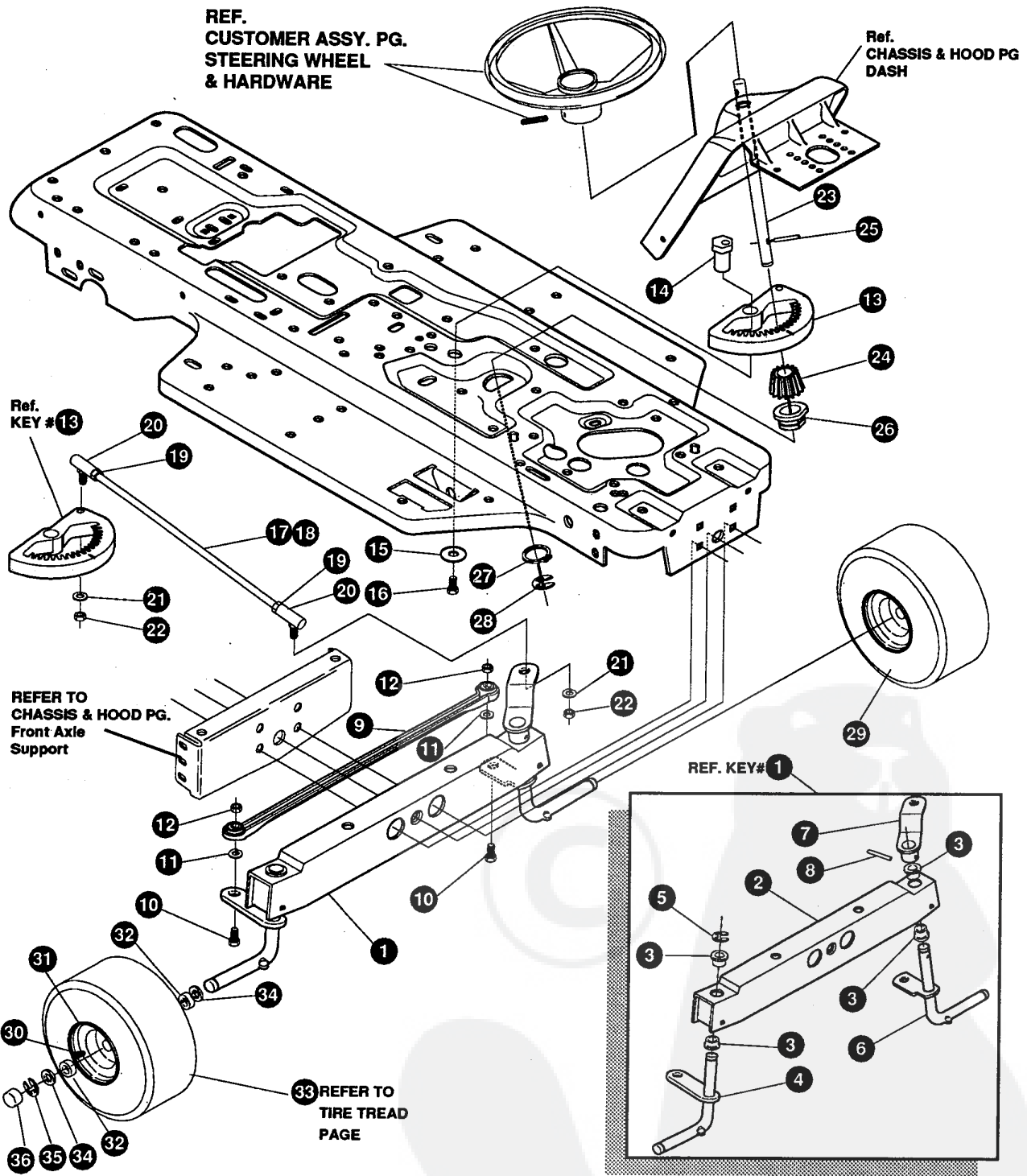

**NOTE: ALWAYS USE ORIGINAL EQUIPMENT PARTS.** Use of service/replacement parts other than original equipment parts may void your warranty.

**ALL UNNUMBERED ITEMS ARE INTERCHANGABLE WITH OPPOSITE SIDE**

321216D



### 30" LAWN TRACTOR MODEL C3554-260

Key#	Part#	Description	Qty.
1.	*	FRONT AXLE ASSEMBLY SF	1
2.	56400	AXLE FRONT	1
3.	50546	BEARING FLANGE	4
4.	310368	SPINDLE,RH	1
5.	36625	RING,RETEX	1
6.	310367	SPINDLE,LH	1
7.	49447	ARM,STEERING LH	1
8.	454565	PIN,SPRING	1
9.	302691	TIE ROD	1
10.	• 122145	SCREW, 3/8-16X1.25 HHC	2
11.	120382	WASHER, .393X.68X.10 REGSPTLK	2
12.	• 1499	NUT, 3/8-16 REGHCTRLK	2
13.	304245	SECTOR GEAR	1
14.	44011	BOLT, .750X1.40 SPSH	1
15.	2483	WASHER, .39IDX1.25ODX.07	1
16.	39573	SCREW, 3/8-24X1.00 NYL	1
17.	56191	DRAG LINK ASSEMBLY	1
18.	56190	DRAG LINK	1
19.	• 124925	NUT, 3/8-24 REGHEXJAM	2
20.	21275	BALL JOINT	2
21.	• 120382	WASHER, EGSPTLK	2
22.	120369	NUT, 3/8-24 REGHEX	2
23.	314109-954	STEERING SHAFT	1
24.	44009	PINION,STEERING SHAFT	1
25.	454565	PIN,SPRING	1
26.	54902	BEARING,1.370X.50 FLANGE STEERING	1
27.	39492	RING,RETEX 1.27X.05	1
28.	36625	RING,RETEX .57X.05	1
29.	41059	ASSEMBLY, TIRE & RIM	2
30.	24167	VALVE STEM	1
31.	39937	WHEEL W/BEARING	1
32.	39979	BEARING, 1.380DX.753ID FLANGE	2
33.		REFER TO TIRE TREAD PAGE	
34.	642	WASHER,FLAT .755X1.31X.075	4
35.	36625	RING,RETEX .57X.05	2
36.	40394	HUB CAP	2

• STANDARD HARDWARE ITEMS  
 \* ORDER INDIVIDUAL PARTS.

# 30" LAWN TRACTOR MODEL C3554-260

## MOTION DRIVE ASSEMBLY

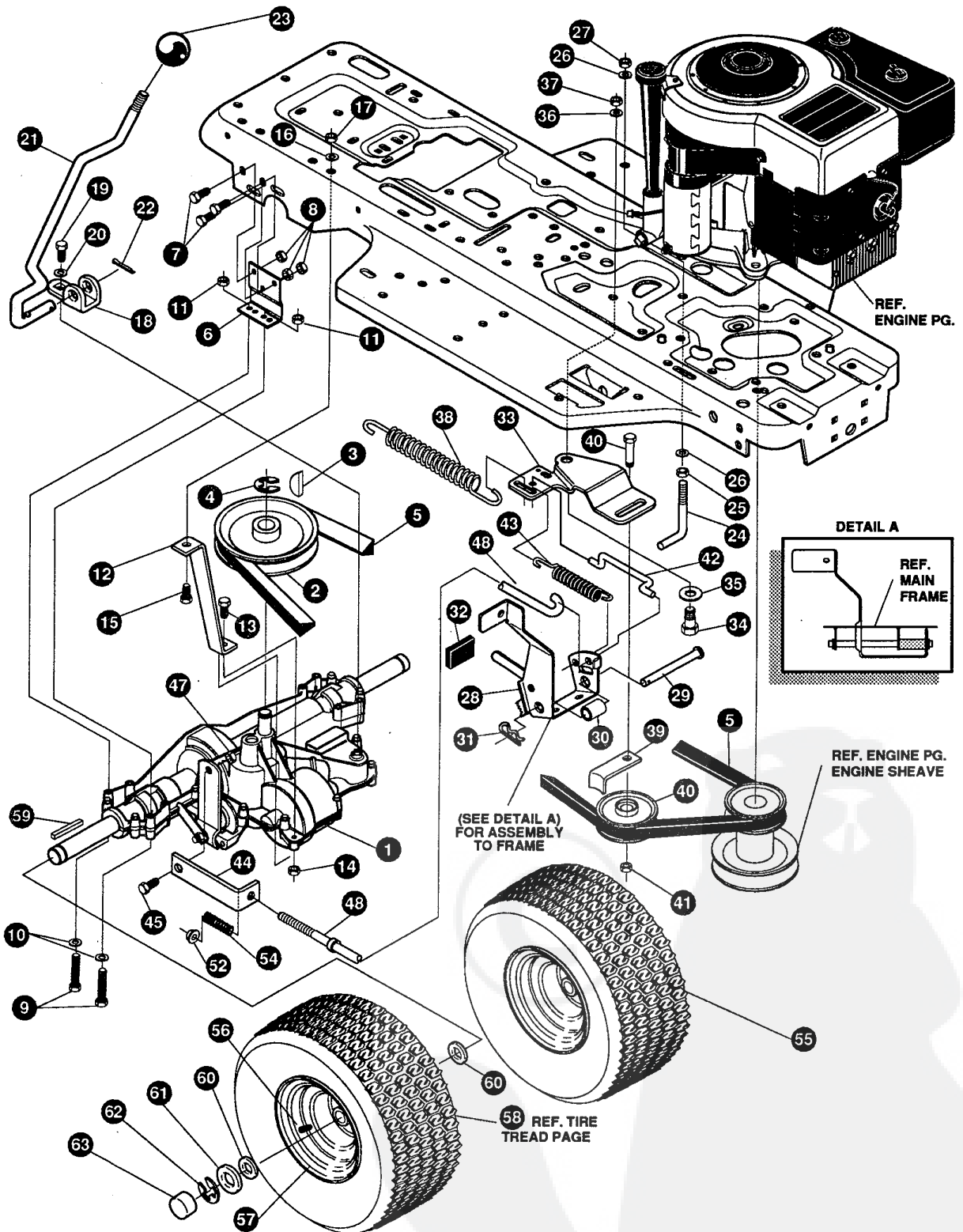

**NOTE: ALWAYS USE ORIGINAL EQUIPMENT PARTS.**  
Use of service/replacement parts other than original equipment parts may void your warranty.

**ALL UNNUMBERED  
ITEMS ARE INTERCHANGABLE  
WITH OPPOSITE SIDE**

321787A

### 30" LAWN TRACTOR MODEL C3554-260

Key#	Part#	Description	Qty.
1.	*	TRANSAXLE, P915-3 SPEED FER	1
2.	302745	PULLEY, IDLER V4L 6.60X	1
3.	3021	KEY, WDRF 606 .750X.187X.312	1
4.	22053	RING, RETEX .58X.035TRU5100-62	1
5.	54758	BELT, V 4L 82.00 SF DRIVE	1
6.	7707	BRACKET, TRANSAXLE	2
7.	• 120228	SCREW, 5/16-18X .63 HHC	6
8.	• 1498	NUT, 5/16-18 REGHEXCTRLK	6
9.	• 180089	SCREW, 5/16-18X2.25 HHC	4
10.	120393	WASHER, FLAT .344X .69X.065	4
11.	• 1498	NUT, 5/16-18 REGHEXCTRLK	4
12.	313587	STABILIZER BRKT	1
13.	• 180087	SCREW, 5/16-18X1.75 HHC	1
14.	• 1498	NUT, 5/16-18 REGHEXCTRLK	1
15.	• 122017	SCREW, 5/16-18X1.00 HHC	1
16.	138485	WASHER, EXLK .320X.61X.03	1
17.	• 1498	NUT, 5/16-18 REGHEXCTRLK	1
18.	12616	BRKT, SHIFT P920-5/F4360-5&3	1
19.	• 56255	SCREW, 1/4-28X .75 NYLHHC	1
20.	57157	WASHER, .750X.250 SP-TRANSAXLE	1
21.	313934	LEVER, SHIFT 915T/A	1
22.	137185	PIN, COTTER .125 DIA X1.00LG	1
23.	55514	KNOB, ROUND 1.50 DIA	1
24.	49896	BELT GUIDE	1
25.	• 271184	NUT, 5/16-18 HEXKEPS	1
26.	120393	WASHER, FLAT .344X .69X.065	2
27.	• 1498	NUT, 5/16-18 REGHEXCTRLK	1
28.	302603	ASSY, BRAKE PEDAL S.F.	1
29.	319676	ROD, PIVOT	1
30.	302601	SPACER, SLEV .53 X .62X1.406	1
31.	56180	PIN, HAIR	2
32.	48761	PAD, CLUTCH/BRAKE PEDAL	1
33.	1306	IDLER ARM BRKT, TRACTION	1
34.	41890	BOLT, .625X .218 HSSH 5/16-18	1
35.	4107	WASHER, FLAT .635X1.31X.07	1
36.	45602	WASHER, FLAT .333X .87X.119	1
37.	• 1498	NUT, 5/16-18 REGHEXCTRLK	1
38.	39659	RETAINER, BELT	1
39.	35374	PULLEY, IDLER V4L 3.06X .62	1
40.	45892	BOLT, 3/8-16X1.50 CARR	1
41.	• 1499	NUT, 3/8-16 REGHXCTRLK	1
42.	43980	ROD, .268 DIA CLUTCH	1
43.	50562	SPRING, 3/8ODX1.625X.055 TENSIO	1
44.	54723	BRACKET, BRAKE ROD	1
45.	20507	BOLT, .437X .156 HSSH 5/16-18	1
46.	120393	WASHER, FLAT .344X .69X.065	1
47.	• 1498	NUT, 5/16-18 REGHEXCTRLK	1
48.	310189	BRAKE ROD, RIDER SF	1
49.	120393	WASHER, FLAT .344X .69X.065	1
50.	121222	PIN, COTTER .090/.086X.75LG	1
51.	• 271184	NUT, 5/16-18 HEXKEPS	1
52.	• 1498	NUT, 5/16-18 REGHEXCTRLK	1
53.	49276	SPRING, 3/4 ODX6.75X.091 TENSIO	1
54.	35410	SPRING, .071 X .62 X 4.37	1
55.	*	TIRE & RIM, PU 18X6.5X8TURFWHI	2
56.	24167	VALVE STEM	1
57.	36182	HUB, WHEEL	1
58.		REF. TIRE TREAD	
59.	52928	KEY, SQUARE .187SQX2.25LG	2
60.	642	WASHER, FLAT .755X1.31X.075	4
61.	42815	WASHER, FLAT .755X1.53X.07	2
62.	36625	RING, RETEX .57X.05TRU5133-75	2
63.	40394	HUB CAP, 1.500ID X 7/8LG	2

• STANDARD HARDWARE ITEMS.

\* ORDER INDIVIDUAL PARTS.

# 30" LAWN TRACTOR MODEL C3554-260

## ENGINE & CONTROL

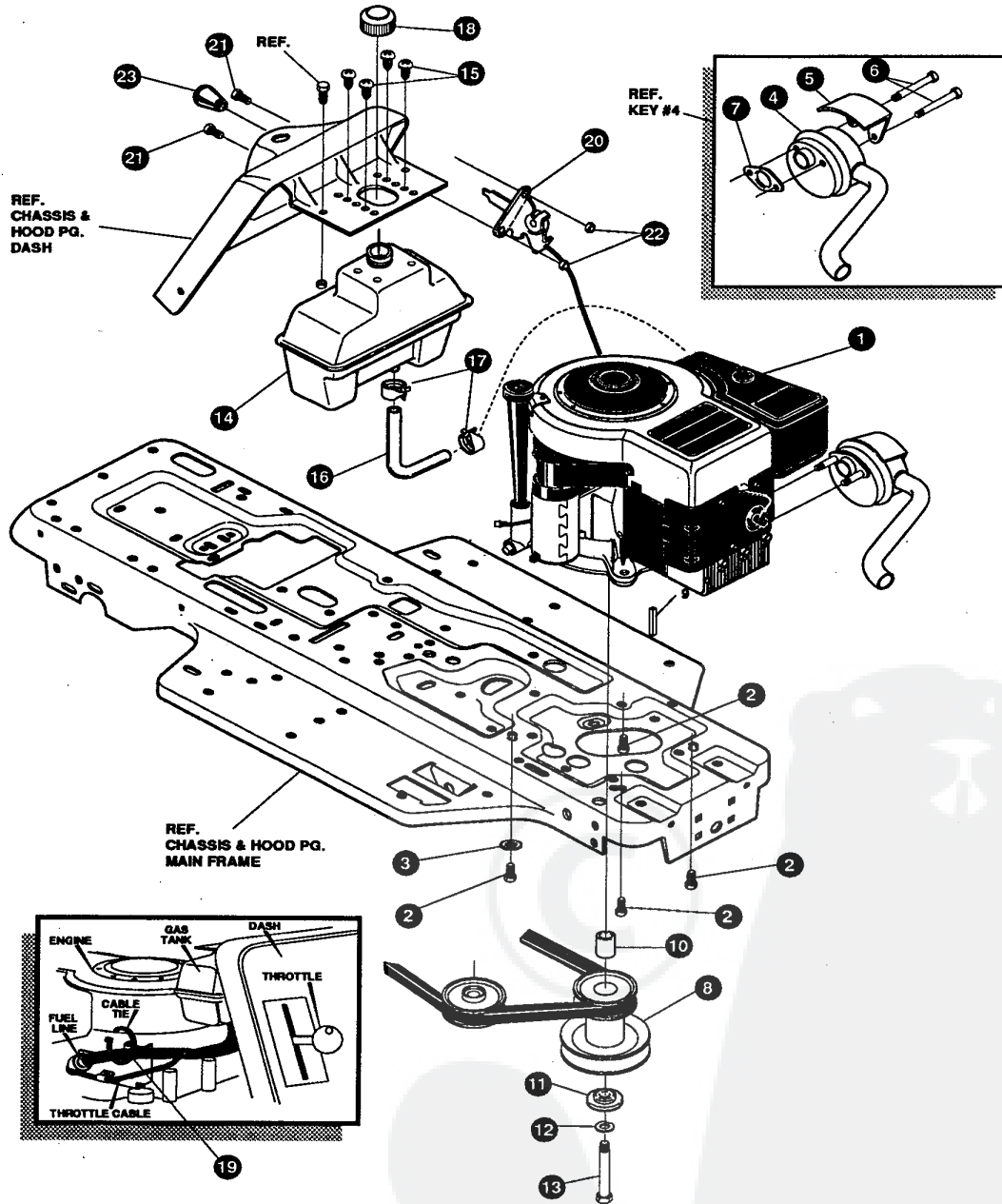

**NOTE: ALWAYS USE ORIGINAL EQUIPMENT PARTS.**  
Use of service/replacement parts other than original equipment parts may void your warranty.

**ALL UNNUMBERED  
ITEMS ARE INTERCHANGABLE  
WITH OPPOSITE SIDE**

324234A

### 30" LAWN TRACTOR MODEL C3554-260

Key#	Part#	Description	Qty.
1	ENGINE	ENGINE 10 HP B&S I/C	1
2	• 50947	SCREW, 3/8-16X1.25 WAHHTAP	4
3	138489	WASHER, EXLK 384X.69X.04	1
4	305367	MUFFLER-LO TONE NELSON EXPORT	1
5	54767	SHIELD, HEAT, FOR ROUND MUFFLER	1
6	• 173063	SCREW, 5/16-18X3.50 HHC	1
7	46708	GASKET, MUFFLER	1
8	300577	PULLEY, ENG 4.00 OFFSET	1
9	303151	KEY, SQUARE .249SQX4.50LG	1
10	304246	SPACER, 1.01X1.484 ENGIN PULLEY	1
11	56431	WASHER, .980IDX1.38ODX.437PILOT	1
12	120383	WASHER, REGSPTLK.459X.78X.12	1
13	• 433146	SCREW, 7/16-20X4.25 HHC BLK PH	1
14	314989	TANK, FUEL 1 GAL	1
15	• 49050	SCREW, 1/4-10X .75PHPNTAPGR2BK	4
16	47452	GAS LINE .25ID BULK LENGTH	12 in.
17	48672	CLAMP, FUEL LINE	2
18	46704	GAS CAP 1-1/2-7 THD BLK	1
19	57444	TIE CABLE	1
20	320031	THROTTLE CONTROL	1
21	• 35291	SCREW, 10-24X .50 SLHHMA	1
22	• 271166	NUT, #10-24 HEXKEPS	2
23	50607	KNOB, ROUND THROTTLE	2

• Indicates STANDARD HARDWARE ITEMS.

# 30" LAWN TRACTOR MODEL C3554-260

## PRE-PAINTED DECK

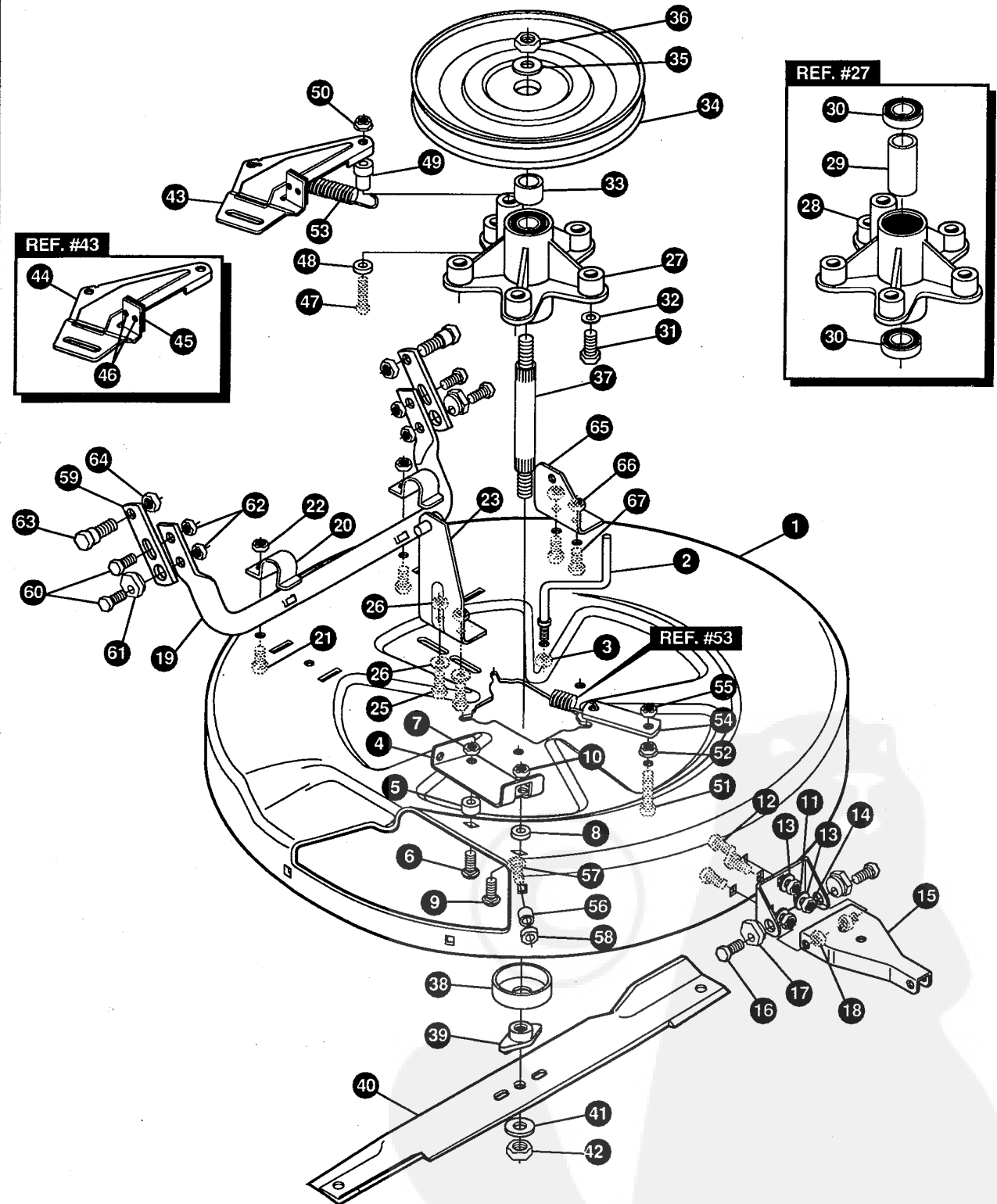

**NOTE: ALWAYS USE ORIGINAL EQUIPMENT PARTS.** Use of service/replacement parts other than original equipment parts may void your warranty.

**ALL UNNUMBERED ITEMS ARE INTERCHANGABLE WITH OPPOSITE SIDE**

321244A

### 30" LAWN TRACTOR MODEL C3554-260

Key#	Part#	Description	Qty.
1	321982	DECK,MOWER 30 INCH S.F.	1
2	57318	GUIDE,BELT 5/16-18 THD.	1
3	1498	NUT,5/16-18 REGHEXCTRLK	1
4	302364	BRACKET CHUTE MOUNT	1
5	314702	SPACER,SLEEVE .344X1.0X5.00	1
6	120230	BOLT, 5/16-18X1.25 CARR GR2	1
7	1498	NUT,5/16-18 REGHEXCTRLK	1
8	45602	WASHER,FLAT .333X.87X.119	1
9	126216	BOLT,5/16-18X.75CARR GR2	1
10	1498	NUT,5/16-18 REGHEXCTRLK	1
11	311237	MS BRACKET MOUNTING,FRONT	1
12	57072	BOLT, 5/16-18 REGHEXCTRLK	3
13	120393	WASHER,FLAT .344X.69X.065	3
14	1498	NUT,5/16-18 REGHEXCTRLK	3
15	311236	BRACKET,BAR,TOW,FRONT	1
16	122017	SCREW,5/16-18X1.00 HHC GR2	2
17	58247	ADJUSTING NUT	2
18	1498	NUT,5/16-18 REGHEXCTRLK	2
19	313372	WS,ASSY,TUBE,PIVOT	1
20	51985	SUPPORT PIVOT TUBE	1
21	180077	SCREW,5.16-18X.75 HHC	2
22	1498	NUT,5/16-18 REGHEXCTRLK	2
23	314119	ASSY LIFT BRKT.	1
24	180077	SCREW,5.16-18X.75 HHC	2
25	120393	WASHER,FLAT .344X.69X.065	2
26	1498	NUT,5/16-18 REGHEXCTRLK	2
27	313588	ASSEMBLY QUILL	1
28	314272	QUILL	1
29	314274	TUBE,SPACER	1
30	313576	BRNG,BALL	2
31	50634	SCREW, 5/16-18X.88 WAHTAP	5
32	138485	WASHER, EXLK .320X.61X.03	5
33	321146	SPACER SLEEVE .790X1.250X.500	1
34	314273	PULLEY ASSEMBLY	1
35	22265	WASHER,FLAT .515X1.38X.119	1
36	1500	NUT,1/2-13 REGHCTRLK	1
37	321144	SHAFT,QUILL 30"MOWER S.F.	1
38	313577	SHIELD,DUST,BEARING	1
39	313584	HUB,BLADE ADAPTOR	1
40	314275	BLADE 30" TD MOWER	1
41	22265	WASHER,FLAT .515X1.38X.119	1
42	1500	NUT,1/2-13 REGHCTRLK	1
43	12229	BRACKET IDLER ASSEMBLY	1
44	313510	BRACKET ARM IDLER	1
45	306973	BRAKE-PAD HARD	1
46	41601	RIVET, OVSET .187DIA X.50LG	2
47	180113	SCREW,5/16-18X3.00 HHC GR5	1
48	45602	WASHER,FLAT .333X.87X.119	1
49	321145	SPACER,SLEEVE .322X.63X2.310	1
50	44108	NUT, 5/16-18 HWDFLCTRLK	1
51	122033	SCREW,5/16-18X1.38 HHC	1
52	44108	NUT,5/16-18 HWDFLCTRLK	1
53	35410	SPRING .071X.62X4.37	1
54	302357	LINK	1
55	1498	NUT,5/16-18 REGHEXCTRLK	1
56	50520	SPACER	1
57	126216	BOLT,5/16-18X.75 CARR.	1
58	1498	NUT,5/16-18 REGHEXCTRLK	1
59	314099	BRACKET,BAR,REAR STABILIZER	2
60	122017	SCREW, 5/16-18X1.00 HHC	4
61	58247	ADJUSTING NUT	2
62	1498	NUT,5/16-18 REGHEXCTRLK	4
63	51940	BOLT, .500X.437 HSH 3/8-16	2
64	1499	NUT,3/8-16 REGHXCTRLK	2
65	320605	BRACKET,BAR LIFT	1
66	1498	NUT,5/16-18 REGHEXCTRLK	2
67	180077	SCREW,5/16-18X.75 HHC GR5	2

**30" LAWN TRACTOR MODEL C3554-260**

**FINAL DECK ASSEMBLY**

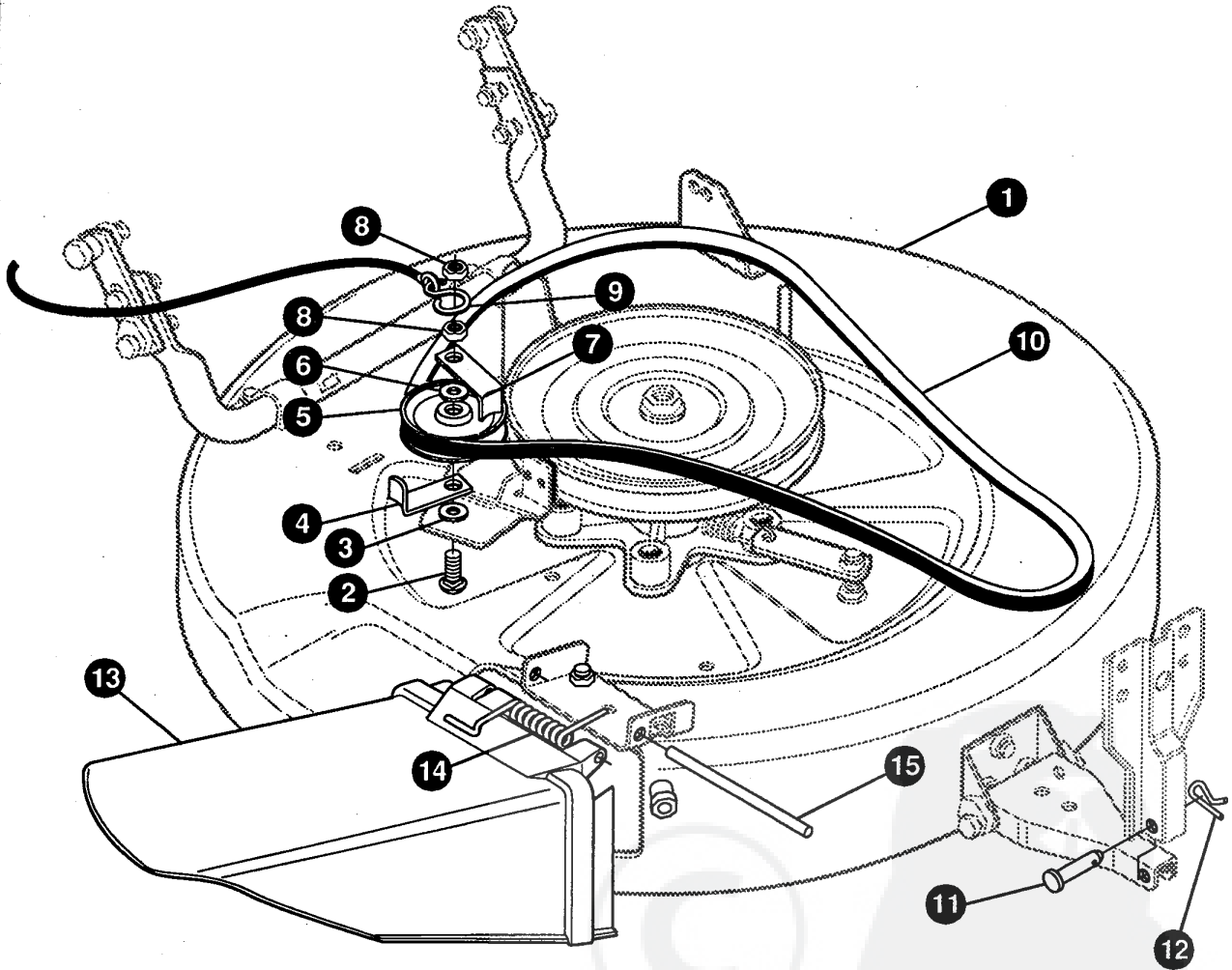

**NOTE: ALWAYS USE ORIGINAL EQUIPMENT PARTS.**  
Use of service/replacement parts other than original equipment parts may void your warranty.

**ALL UNNUMBERED  
ITEMS ARE INTERCHANGABLE  
WITH OPPOSITE SIDE**

321266A



### 30" LAWN TRACTOR MODEL C3554-260

Key#	Part#	Description	Qty.
1.	*	DECK, 30SD ASSY PTD BLK 853	
2.	301340	BOLT, 3/8-16X2.50 CARR	1
3.	22265	WASHER, FLASHER .515 X 1.38 X .119 PL	1
4.	39659	RETAINER,BELT	1
5.	45074	PULLEY, IDLER V4L 3.06X .72	1
6.	25210	WASHER, FLAT .392X1.25X.09	1
7.	39659	RETAINER,BELT	1
8.	1499	NUT, 3/8-16 REGHXCTRLK	2
9.	310734	HOOK, S, 10 GA. STEEL	1
10.	321147	BELT, V 4L 54.0 - MOD SEC	1
11.	47816	PIN, .495X1.750 CLEVIS-SHORT	1
12.	56180	PIN, HAIR .091 DIA X 1.62LG	1
13.	315314	CHUTE,DEFLECTOR	1
14.	314975	SPRING TORSION CHUTE DEF.	1
15.	304424	ROD,PIVOT DECK .312DX7.25	1

\* ORDER INDIVIDUAL PARTS.

**30" LAWN TRACTOR MODEL C3554-260**

**ELECTRICAL ASSEMBLY**

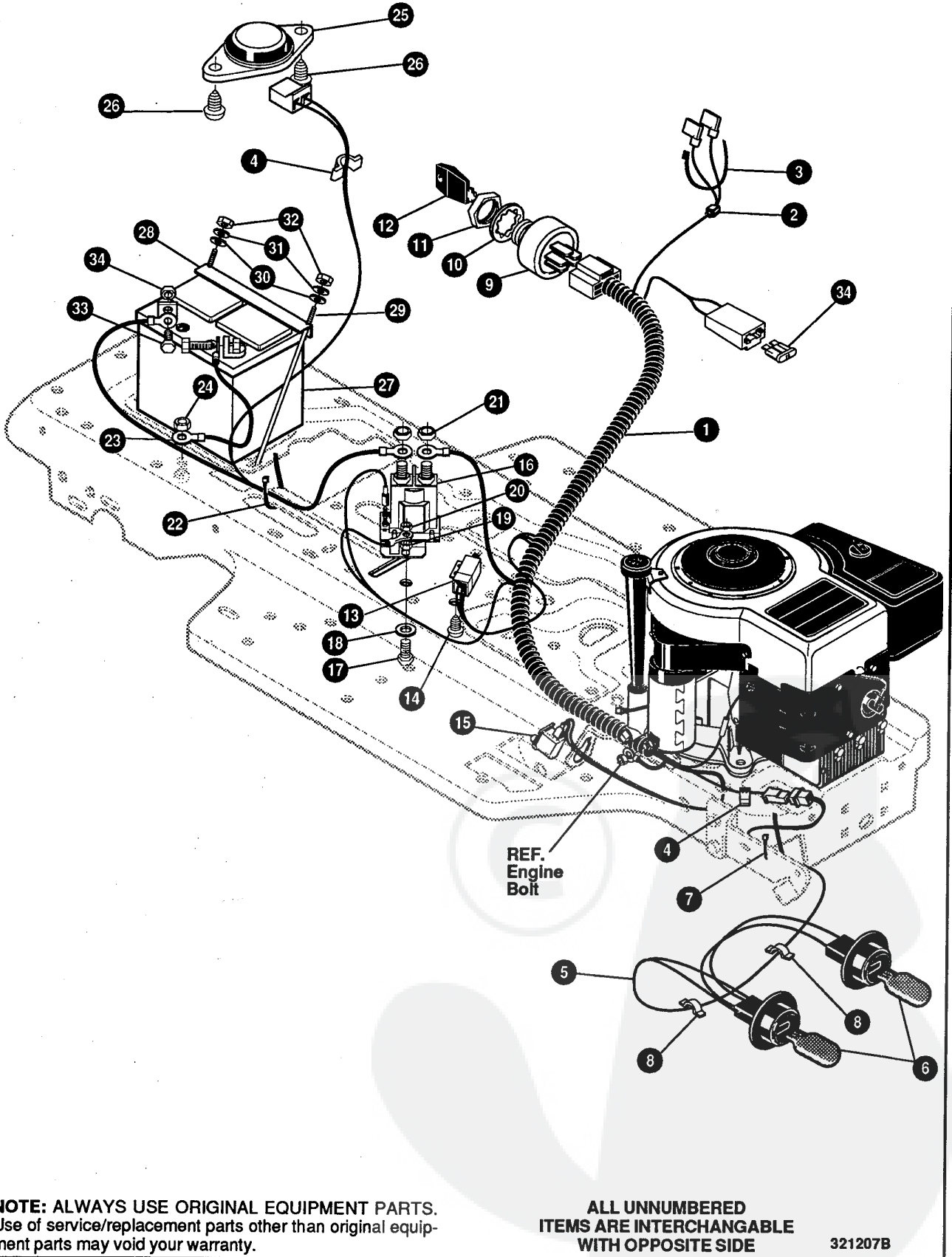



# 30" LAWN TRACTOR MODEL C3554-260

## DECALS

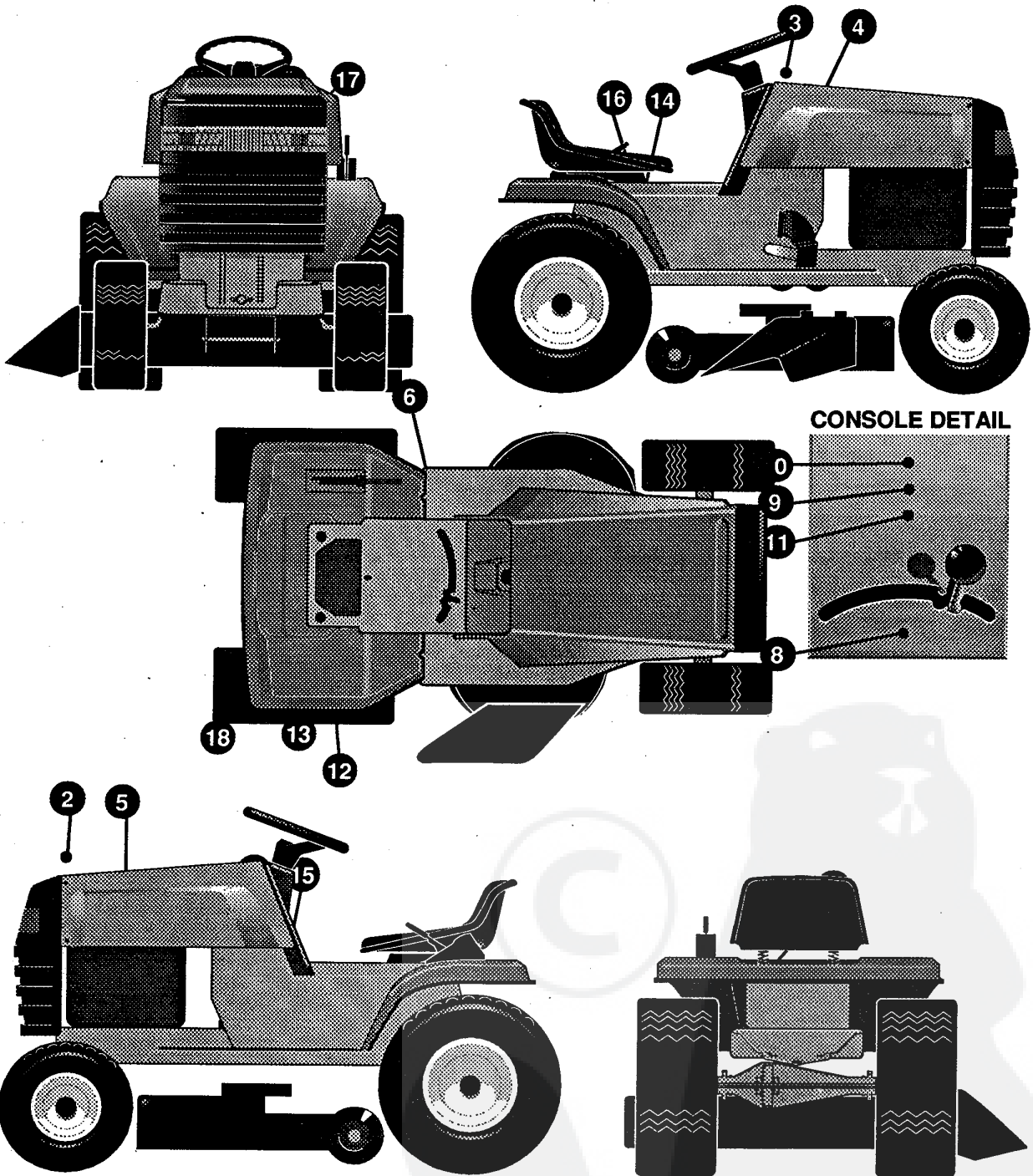

324236

### 30" LAWN TRACTOR MODEL C3554-260

Key#	Part#	Description	Qty.
1.	55832	PAD, FOAM TOP HOOD H-4	1
2.	55833	PAD, FOAM HOOD H-4 SIDE LH	1
3.	55834	PAD, FOAM HOOD H-4 SIDE RH	1
4.	314456	DECAL, HOODSIDE RH H-21	1
5.	314457	DECAL, HOODSIDE LH H-21	1
6.	320686	DECAL DASH, DYNAMARK	1
7.	305770	DECAL, CAUTION TRIANGLE EUROPE	1
8.	307047	DECAL, 3-SPEED CONSOLE TOP	1
9.	69524	DECAL, INSTRUCT CONSOLE TOP GER	1
10.	69525	DECAL, INSTRUCT CONSOLE TOP FR	1
11.	307383	DECAL, INSTR. CONSOLE TOP ENGL	1
12.	310553	DECAL, DANGER ENGLISH	1
13.	68902	DECAL, WARNING, FRENCH/GERMAN	1
14.	314460	DECAL, CONSOLE RH STRETCH FRM	1
15.	314461	DECAL, CONSOLE LH STRETCH FRM	1
16.	323627	NAME PLATE, 8/30 WHITE	2
17.	301897	DECAL, LIFT DECK BLADE HEIGHT	1
18.	68901	DECAL, BLADE HEIGHT ADJ. EUROPE	1
19.	68903	DECAL, BRAKE/CLUTCH EUROPE	1
20.	67667	DECAL, CHECK OIL LEVEL	1
21.		REFERENCE ONLY	
22.		REFERENCE ONLY	

**30" LAWN TRACTOR MODEL C3554-260**

**CUSTOMER ASSEMBLY**

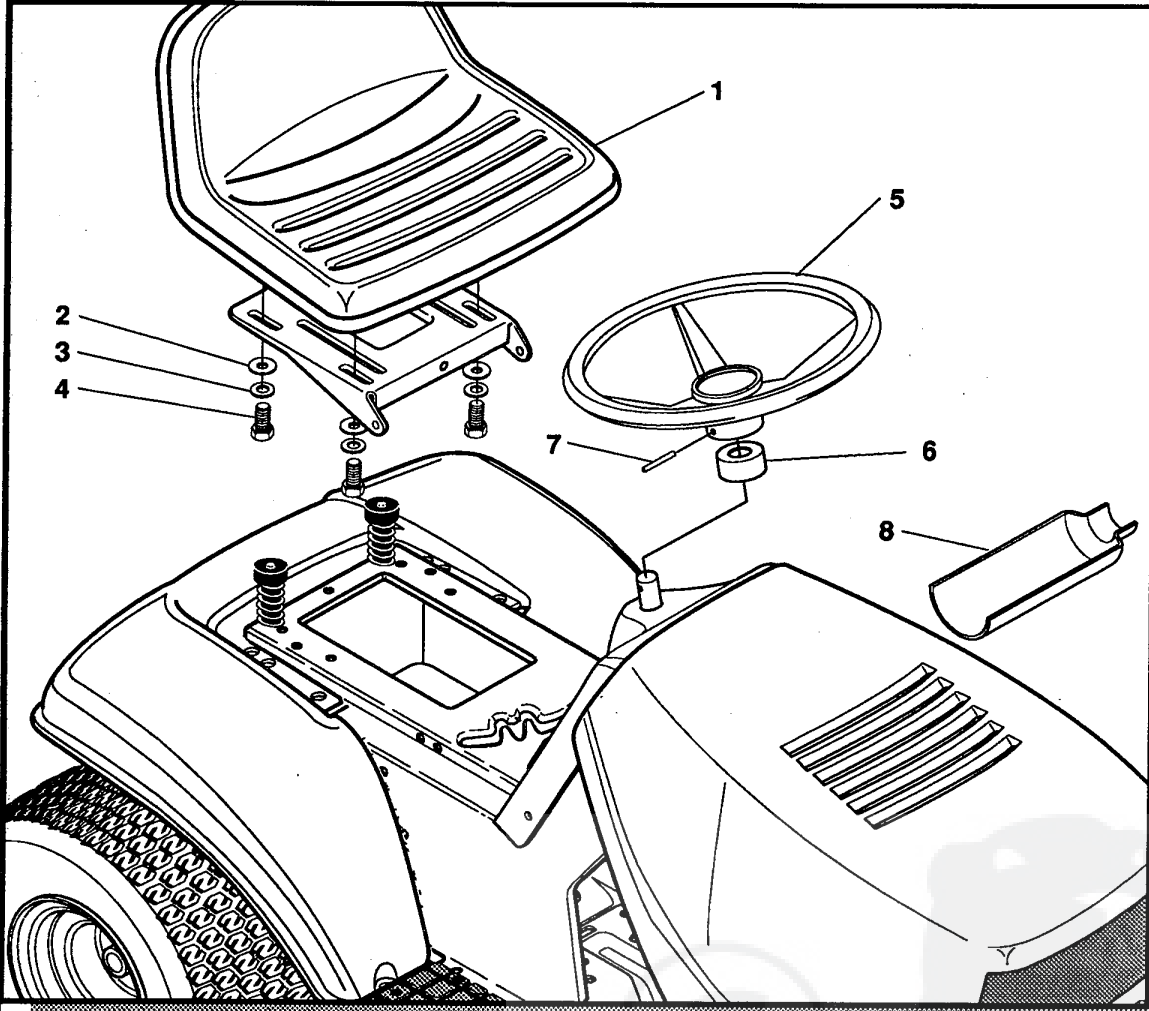

**CUSTOMER ASSEMBLY VIEW**

315134 PARTS BAG ASSY QTY1

Key#	Part#	Description	Qty
1	57452	SEAT MV350	1
2	120393	WASHER,FLAT .344X.69X.065	4
3	120638	WASHER, HV SPLTLK .328X.60X.109	4
4	122007	SCREW, 5/16-18X.75 HHC	4
5	301251	STEERING WHEEL	1
6	323758	STEERING, SLEEVE	1
7	456378	ROLL PIN .250DIAX2.0LG	1
8	54873	OIL TROUGH	1

316235B

# TREAD PATTERNS

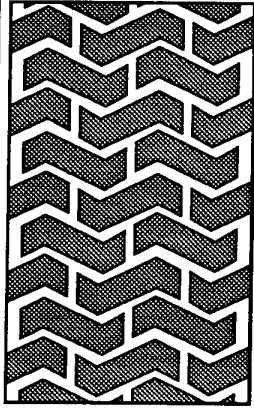

**"A"**

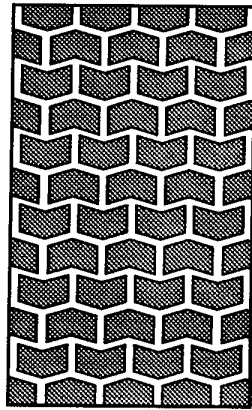

**"B"**

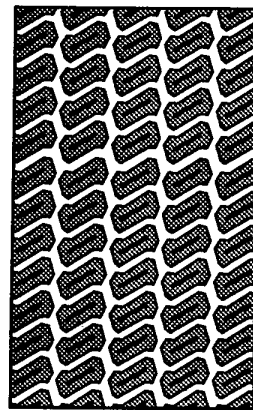

**"C"**

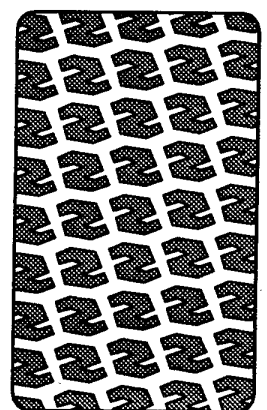

**"D"**

TIRE SIZE	"A"	"B"	"C"	"D"
11 X 4.00 - 5	42295	319679		
13 X 5.00 - 6	41060	319680		
15 X 6.00 - 6	39830	316702	301140	313952
16 X 6.50 - 8	41081	319682		314539
18 X 8.50 - 8	319683	317400		
18 X 9.50 - 8	41106	316701		313950
20 X 8.00 - 8	319685	319684	57164	314584
20 X 10.00 - 8	58276	319686		313654
20 X 10.00 - 10	55893	319687		
23 X 9.50 - 12	53655	319690	319689	314370

## ACCESSORIES

Contact the dealer where your tractor was purchased for the available accessories. If you are unable to contact the dealer, write to the address on the front cover of this manual.

### Rear Engine Rider

Model	Description
5708-16	Bagger - Fits 32" Side Discharge
5708-17	Bagger - Fits 36" Side Discharge
5709-02	Front Weight Box - holds 35 lbs.
5648-16	Lawn Sweeper w/dump Release

### Lawn Tractor

Model	Description
5708-22	Bagger - Fits 30" Top Discharge
5708-13	Bagger - Fits 36", 38", 39" & 45" Side Discharge
5708-14	Bagger - Fits 40", 42", 43" & 46" Side Discharge
5661-06	42" Snowblade
5661-08	48" Snowblade
5592-00	Tire Chains - 18" x 6.50"
5585-00	Tire Chains - 18" x 9.50" & 20" x 8"
5672-01	Wheel Weights - Front - 1 pr. w/mtg. hdw. - Fits 15" tires
5673-02	Wheel Weights - Rear - 1 pr. w/mtg. hdw. - Fits 18" & 20" tires
5709-03	Front Weights - Fits 30" & 32" Side Discharge
5648-16	Lawn Sweeper w/dump Release
5705-06	42" Two-Stage Snowblower

### Garden Tractor - Light Ground Engaging

Model	Description
5708-13	Bagger - Fits 36", 38", 39", & 45" Side Discharge
5708-14	Bagger - Fits 40", 42", 43" & 46" Side Discharge"
5661-06	42" Snowblade
5672-01	Wheel Weights - Front 1 pr. w/mtg. hdw. - Fits 15" tires
5673-02	Wheel Weights - Rear - 1 pr. w/mtg. hdw. - Fits 18" & 20" tires
5648-16	Lawn Sweeper w/dump Release
5667-02	Sleeve Hitch - w/lift bar
5668-01	Adaptor (sleeve hitch) for use w/23" tires
5706-00	Tire Chains - 20" x 10"
5671-00	Tire Chains - 23" x 9.50"
5672-02	Wheel Weights - Front - 1 pr. w/mtg. hdw. Fits 16" tires
5673-00	Wheel Weights - Rear - 1 pr. w/mtg. hdw. Fits 23" tires
5674-01*	10" One Bottom Moldboard Plow
5675-01*	Cultivator - 7 row - Adj. 6" - 42" width
5676-01*	Disc Harrow - 8" & 11" disc - Adj. width & disc angle
5677-02*	Tiller - 5 H.P. Self-Powered - 28" width
5705-06	42" Two-Stage Snowblower
5661-08	48" Snowblade

### Euro Four Wheel Steer

Model	Description
5708-14	Bagger - Fits 40", 42", 43" & 46" Side Discharge
5705-05	42" One-Stage Snowblower
5661-07	48" Snowblade
5709-04	Rear Weight Box
5648-16	Lawn Sweeper w/dump Release
5706-00	Tire Chains 20" x 10"
5671-00	Tire Chains 23" x 9.50"
5672-02	Wheel Weights - Front - 1 pr. w/mtg. hdw. Fits 16" tires
5673-00	Wheel Weights - Rear - 1 pr. w/mtg. hdw. Fits 23" tires
5672-01	Wheel Weights - Front - 1 pr. w/mtg. hdw. Fits 15" tires
5673-02	Wheel Weights - Rear - 1 pr. w/mtg. hdw. Fits 18" & 20" tires

### Euro Two Wheel Steer Garden Tractor

Model	Description
5667-04	Sleeve Hitch - w/lift bar Fits 46"
5674-01*	10" One Bottom Moldboard Plow
5675-01*	Cultivator - 7 row - Adj. 6" - 42" width
5676-01*	Disc Harrow 8" & 11" Disc. Adj. width & disc angle
5677-02*	Tiller 5 H.P. Self-Powered - 28" width
5648-16	Lawn Sweeper w/dump Release

\*Requires a sleeve hitch