

REPAIR PARTS MANUAL

39" - 12.5 H.P. LAWN TRACTOR

MODEL C3560-070

ONE YEAR LIMITED WARRANTY

For one (1) year from date of purchase by the first consumer for residential use (thirty (30) days commercial use), NOMA Outdoor Products Incorporated warrants that it will replace free of charge, including labor, any original part of any NOMA Outdoor Products Incorporated product found to be defective by any authorized Service Dealer or the factory, except the battery which is warranted for ninety (90) days from date of purchase.

This warranty does not cover engine, transmission, transaxle or differential (these items are covered by their manufacturer's own warranty). This warranty does not cover parts that have failed due to normal wear or parts that have failed subject to misuse or abuse. Transportation of the unit or part to and from an authorized Service Dealer or factory is the responsibility of the owner.

A step by step explanation as to what procedure should be followed for this warranty is:

1. If a part becomes defective, contact the store where the unit was purchased for the name and address of the authorized Service Dealer nearest to you.
2. If you cannot locate an authorized Service Dealer, write Service Department of NOMA Outdoor Products Incorporated for the name and address of the authorized Service Dealer in your area or call the Service Department at 1-901-422-1690.
3. Return the defective product, along with proof of purchase to such authorized Service Dealer for replacement of any defective part where covered by this warranty.

There is no other express warranty. Implied warranties, including those of merchantability and fitness for a particular purpose are limited to one (1) year from date of purchase. Liability for incidental or consequential damages are excluded.

Some states do not allow limitations on how long an implied warranty lasts, so the above limitation may not apply to you. Some states do not allow the exclusion of incidental or consequential damages, so the above exclusion may not apply to you. This warranty gives you specific legal rights, and you may have other rights which vary from state to state.

NOMA Outdoor Products Incorporated

Caller 8000

Jackson, TN 38308-8000

UNIT PARTS AND SERVICE

Fill in and mail the registration card packed with the unit. For service other than covered in this manual, contact an authorized service dealer. When ordering repair parts, always give the following information: 1. The Part Name; 2. The Part Number; 3. The Quantity desired; 4. The Full (eight digit) Model Number of the unit. The model number will be found on a plate attached to the unit.



Look for this symbol. It means - ATTENTION! BECOME ALERT! A HAZARD TO OPERATOR, BYSTANDER, PROPERTY OR EQUIPMENT MAY EXIST.

NOMA Outdoor Products Incorporated

Caller 8000

Jackson, TN 38308-8000

Part No. 324698

0392



SAFETY RULES

THESE INSTRUCTIONS ARE FOR YOUR PROTECTION. PLEASE READ THEM CAREFULLY.



IMPORTANT

THIS CUTTING MACHINE IS CAPABLE OF AMPUTATING HANDS AND FEET AND THROWING OBJECTS. FAILURE TO OBSERVE THE FOLLOWING SAFETY INSTRUCTIONS COULD RESULT IN SERIOUS INJURY OR DEATH.

I. GENERAL OPERATION:

- Know controls and how to stop quickly.
- Read, understand, and follow all instructions in the manual and on the machine before starting.
- Only allow responsible adults, who are familiar with instructions, to operate the machine.
- Wear safety glasses or eye shields when assembling or operating the machine.
- Do not operate machine when barefooted. Always wear substantial footwear, preferably steel-toed shoes.
- Do not wear loose fitting clothing that could get caught in moving parts.
- Clear the area of objects such as rocks, toys, wire, etc., which could be picked up and thrown by the blade(s).
- Be sure the area is clear of other people before mowing. Stop machine if anyone enters the area.
- Never carry passengers.
- Do not mow in reverse unless absolutely necessary. Always look down and behind before and while backing.
- Be aware of the mower discharge direction and do not point it at anyone. Do not operate the mower without either the entire grass catcher or the guard in place.
- Slow down before turning.
- Never leave a running machine unattended. Always turn off blades, set parking brake, stop engine, and remove keys before dismounting.
- Turn off blade(s) when not mowing.
- Stop engine before removing grass catcher or unclogging chute.
- Mow only in daylight or good artificial light.
- Do not operate the machine while under the influence of alcohol or drugs.
- Watch for traffic when operating near or crossing roadways.
- Use care when mowing around a fixed object to prevent the blade(s) from striking it. Never deliberately run over any foreign object.
- Use extra care when loading or unloading the machine into a trailer or truck.
- Use care when pulling loads or using heavy equipment.
 - a. Use only approved drawbar hitch points.
 - b. Limit loads to those that you can safely control.
 - c. Do not turn sharply. Use care when backing.
 - d. Use counterweight(s), wheel weight or tire chains when suggested in attachment(s) instructions.

SLOPE OPERATION:

Slopes are a major factor related to loss-of-control and tip-over accidents, which can result in severe injury or death. *All slopes require extra caution.* If you cannot back up the slope or if you feel neasy on it, do not mow it.

○

Mow up and down slopes, not across.
 Remove obstacles such as rocks, tree limbs, etc.
 Watch for holes, ruts, or bumps. Uneven terrain could overturn the machine. *Tall grass can hide obstacles.*
 Use slow speed. Choose a low gear so that you will not have to stop or shift while on the slope.
 Follow the manufacturer's recommendations for wheel weights or counterweights to improve stability.
 Use extra care with grass catchers or other attachments. These can change the stability of the machine.
 Keep all movement on the slopes *slow and gradual*. Do not make sudden changes in speed or direction.
 Avoid starting or stopping on a slope. If tires lose traction, turn off the blade(s) and proceed slowly *straight* down the slope.

○ NOT

Do not turn on slopes unless necessary, and then slowly and gradually downhill, if possible.
 Do not mow near drop-offs, ditches or embankments. The

mower could suddenly turn over if a wheel is over the edge of a cliff or ditch, or if an edge caves in.

- Do not mow on wet grass. Reduced traction could cause sliding.
- Do not try to stabilize the machine by putting your foot on the ground.
- Do not use grass catcher on steep slopes.

III. CHILDREN:

Tragic accidents can occur if the operator is not alert to the presence of children. Children are often attracted to the machine and the mowing activity. *Never* assume that children will remain where you last saw them.

- Keep children out of the mowing area and under the watchful care of another responsible adult.
- Be alert and turn machine off if children enter the area.
- Before and when backing, look behind and *down* for small children.
- Never carry children. They may fall off and be seriously injured or interfere with safe machine operation.
- Never allow children to operate the machine.
- Use extra care when approaching blind corners, shrubs, trees, or other objects that may obscure vision.

IV. SERVICE:

- Use extra care in handling gasoline and other fuels. They are flammable and vapors are explosive.
 - a. Use only an approved container.
 - b. Never remove gas cap or add fuel with the engine running. Allow engine to cool before refueling. Do not smoke.
 - c. Never refuel the machine indoors.
 - d. Never store the machine or fuel container inside where there is an open flame, such as in a water heater.
- Check fuel supply before each use allowing space for expansion as the heat of the engine and/or sun can cause gasoline to expand and overflow the tank.
- Use extra care when handling battery acid. Acid contact with skin may cause severe burns. Eye contact may cause blindness.
- Use extra care when servicing the battery. Explosive gas is produced in the battery. Do not service the battery while smoking or near an open spark or flame. This may cause the battery to explode causing serious injury.
- Never run a machine inside a closed area. Exhaust fumes contain CARBON MONOXIDE, an ODORLESS and DEADLY GAS.
- Keep nuts and bolts, especially blade attachment bolts, tight and keep equipment in good condition.
- Never tamper with safety devices. Check their operation regularly.
- Do not change the engine governor settings or overspeed engine.
- Reduce fire hazards. Keep machine free of grass, leaves, or other debris build-up. Clean up oil or fuel spillage. Allow machine to cool before storing.
- Stop and inspect the equipment if you strike an object. Repair, if necessary, before restarting.
- Never make adjustments or repairs with the engine running.
- Grass catcher components are subject to wear, damage, and deterioration, which could expose moving parts or allow objects to be thrown. Frequently check components and replace with manufacturer's recommended parts, when necessary.
- Mower blade(s) are sharp and can cut. Wrap the blade(s) or wear gloves, and use extra caution when servicing them.
- Check brake operation frequently. Adjust and service as required.



LOOK FOR THIS SYMBOL TO POINT OUT IMPORTANT SAFETY PRECAUTIONS. IT MEANS--ATTENTION!!! BECOME ALERT!!! YOUR SAFETY IS INVOLVED.

OWNER'S INFORMATION

Record the following information about your unit so that you will be able to provide it in case of loss or theft.

MODEL NUMBER: - (Enter complete 8 digit number from model plate on unit)
PURCHASE DATE: ___ / ___ / ___ CODE NO.: _____ SERIAL NO.: _____
DEALER'S NAME AND ADDRESS: _____
CITY: _____ STATE: _____ TELEPHONE: _____

CONTENTS OF SHIPPING CARTON

- 1 - Lawn Tractor with 39 inch Mower Deck
- 1 - Operator's Manual
- 1 - Repair Parts Manual
- 1 - Engine Manual
- 1 - Steering Wheel (see Note)
- 1 - Seat (see Note)
- 2 - Tire & Rim Assemblies
- 1 - Bag of Assembly Parts Containing (see Note):
 - 1 - Oil Drain Trough
 - 4 - 5/16 x 3/4 inch Hex Head Screws
 - 4 - 5/16 inch Split Lockwashers
 - 4 - 11/32 inch Flatwashers
 - 1 - Spring Pin
 - 1 - Steering Shaft Cover
 - 4 - Flatwashers
 - 2 - Retaining Rings
 - 2 - Hub Caps
 - 1 - Shift Knob

NOTE: Refer to page 22 & 23 (Customer Assembly Parts) for more detailed description.

TOOLS REQUIRED FOR ASSEMBLY

- 2 - 7/16 inch Wrenches (or adjustable wrench)
- 1 - 1/2 inch Wrench (or adjustable wrench)
- 1 - Small Phillips Screwdriver with a 1/4 inch shank
- 1 - Hammer

HOW TO MEASURE SCREW SIZE (5/16 x 1 1/2 INCH)

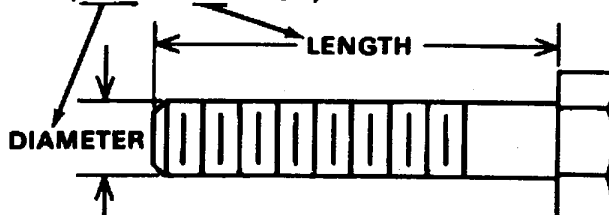

DANGER



This lawn tractor can be dangerous if carelessly used.

Read your Operator's Manual thoroughly before operating your lawn tractor.

Always wear safety glasses or eye shields while assembling or operating your lawn tractor.

DO NOT carry passengers at any time.

Keep your hands, feet, hair and loose clothing away from the discharge area, the underside of the mower deck or any moving parts while the engine is running.

DO NOT allow children or young teenagers to operate or be near your lawn tractor while it is operating.

ALWAYS GIVE THE FOLLOWING INFORMATION WHEN ORDERING REPAIR PARTS:

1. The PART NUMBER; 2. The PART NAME; 3. QUANTITY DESIRED; 4. The MODEL NUMBER (As shown on Model Plate).

SEND PART ORDERS AS PER INSTRUCTIONS ON THE FRONT PAGE.

DO NOT USE KEY NUMBERS WHEN ORDERING REPAIR PARTS, ALWAYS USE PART NUMBERS.

All replacement parts will be supplied in current production colors or in a neutral color.

A handling fee is applicable to small parts orders.

YOUR UNIT IS RIGHT HAND (RH) OR LEFT HAND(LH) AS YOU STAND BEHIND IT.

39" LAWN TRACTOR MODEL C3560-070

CHASSIS & HOOD ASSEMBLY

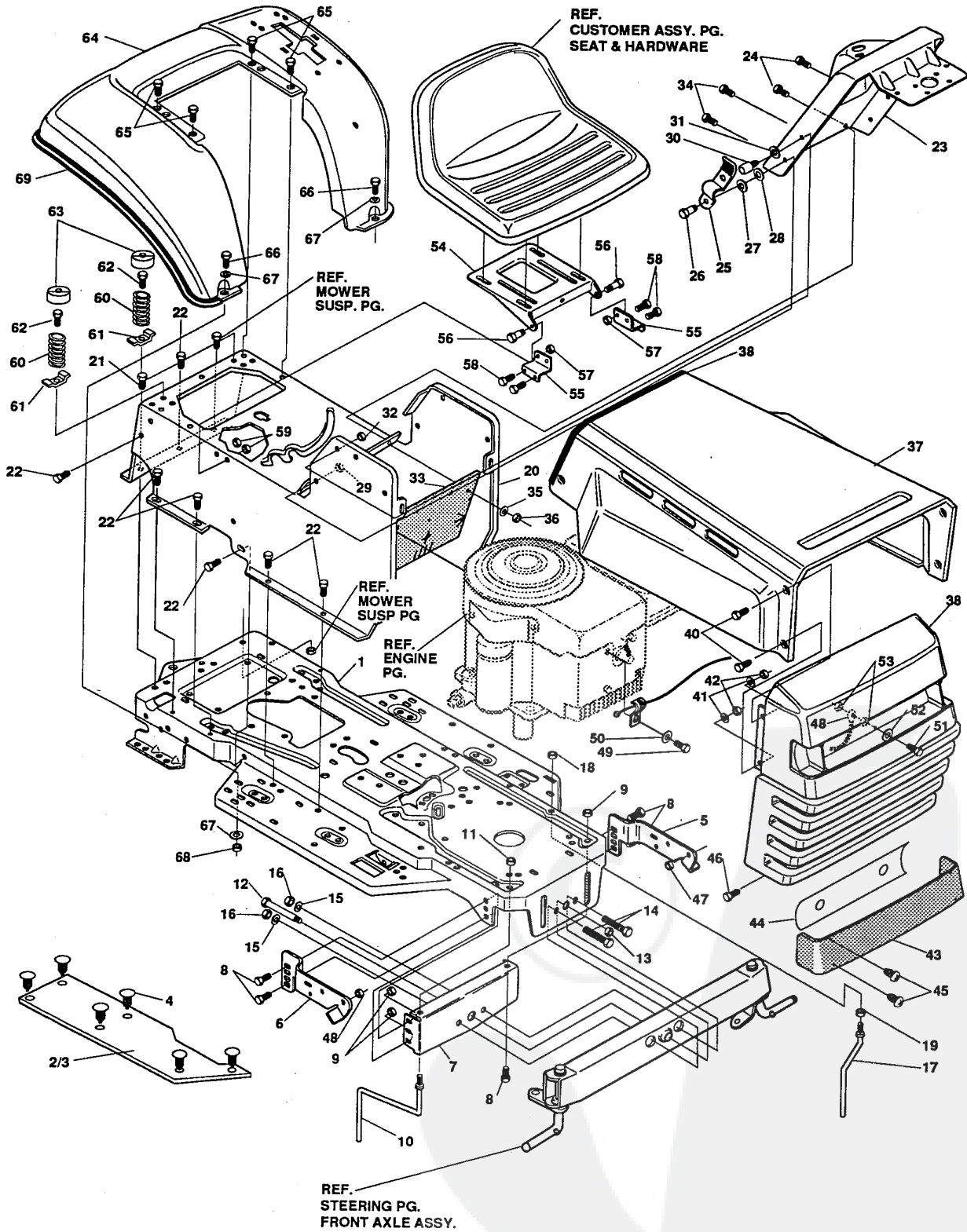

NOTE: ALWAYS USE ORIGINAL EQUIPMENT PARTS. Use of service/replacement parts other than original equipment parts may void your warranty.

ALL UNNUMBERED ITEMS ARE INTERCHANGEABLE WITH OPPOSITE SIDE

321677A

39" LAWN TRACTOR MODEL C3560-070

Key#	Part#	Description	Qty.
1	321708-860	FRAME,LF MAIN P920/F4360	1
2	310005	FOOTPAD, LH	1
3	310006	FOOTPAD, RH	1
4	309235	FASTENER, RATCHET	12
5	313047	BRKT, GRILL LH	1
6	313048	BRKT, GRILL RH	1
7	56361	BRACKET, FRONT AXLE	1
8	56030	SCREW, 5/16-18X.75WDFLLK GR5	5
9	55273	NUT, 5/16-18 HXWDFLLK	5
10	300440	GUIDE, BELT, RIDER	1
11	◇ 1498	NUT, 5/16-18 REGHEXCTRLK	1
12	308207	BOLT, .625X2.180 HSSH 1/2-13NC	1
13	◇ 309008	NUT, 1/2-13 HXJAMCTRLK	1
14	◇ 122207	SCREW, 3/8-16X3.00 HHC GR2	2
15	2483	WASHER, .39IDX1.25DX.07 BELLVIL	2
16	◇ 1499	NUT, 3/8-16 REGHXCTRLK	2
17	300635	GUIDE, BELT SHORT 15" WHEEL	1
18	124824	NUT, 5/16-18 HEXJAM	1
19	271190	NUT, 3/8-16 HEXKEPS	1
20	309657-860	CONSOLE LF TOPSHIFT	1
21	35497	SCREW, 5/16-18X .50 WAHHTAP	1
22	995346	SCREW, 1/4-20X .50 WAHHTAP	13
23	309447-860	DASHBOARD, NF SUSP DYNA	1
24	995346	SCREW, 1/4-20X .50 WAHHTAP	2
25	57159	LATCH, .94WDX.047 ASSY HOOD	2
26	8482	BOLT, .375X .156 HSSH 5/16-18	2
27	120394	WASHER, FLAT .406X .81X.065	2
28	120393	WASHER, FLAT .344X .69X.065	2
29	◇ 1498	NUT, 5/16-18 REGHEXCTRLK	2
30	53446	PIN, 5/16-18 HOOD LATCH	2
31	138538	WASHER, REGINTLK.320X.61X.03	2
32	45174	NUT, 5/16-18 HEXWDFLLK WHIZ	2
33	312306	BAFFLE CONSOLE	1
34	300314	SCREW, 1/4-20 X .88 WAHHTAP	2
35	120392	WASHER FLAT, .281 X .63 X.065	2
36	1502	NUT, 1/4-20 REGHEXCTRLK	2
37	314537-860	HOOD, LF H-20 DYNA/PRO	1
38	47453	EDGING, WIDE	27.5"
39	314476	GRILLE, DYNA-PRO	1
40	◇ 274672	SCREW, 1/4-20X .63 WAHHC GR2	4
41	120392	WASHER, FLAT .281X .63X.065	4
42	◇ 1502	NUT, 1/4-20 REGHEXCTRLK	4
43	302333	LENS, SMOKED W/TAB NO LOGO	1
44	314948	FOIL, LENS DYNA-PRO REFLECTOR	1
45	57796	SCREW, #6 X .50 PLASTITE	4
46	36149	BOLT, .375X .500 HSSH 5/16-18	2
47	◇ 1498	NUT, 5/16-18 REGHEXCTRLK	2
48	310748	LANYARD, HOOD	1
49	◇ 180018	SCREW, 1/4-20X .62 HHC	1
50	◇ 120380	WASHER, REGSPTLK.263X.49X.07	1
51	◇ 48900	SCREW, 1/4-20X .75 HHC GR2	1
52	120392	WASHER, FLAT .281X .63X.065	1
53	◇ 1502	NUT, 1/4-20 REGHEXCTRLK	2
54	58367-853	PLATE, SEAT F-5 SF & LF	1
55	310660-853	BRACKET, F-5 SEAT SUPPORT	1
56	20507	BOLT, .437X .156 HSSH 5/16-18	2
57	◇ 1498	NUT, 5/16-18 REGHEXCTRLK	2
58	◇ 48901	SCREW, 5/16-18X .63 HHC GR2	4
59	◇ 1498	NUT, 5/16-18 REGHEXCTRLK	4
60	57153	SPRING, SEAT 2.63LG,1.49OD	2
61	1341	CLAMP, SPRING 1.17"ID	2
62	44811	SCREW, 1/4-20X .75 HXWATAP	2
63	56907	COVER, SEAT SPRING 1.5IDX1.0LG	2
64	58334-860	FENDER, F-5 SUSP	1
65	995346	SCREW, 1/4-20X .50 WAHHTAP	4
66	◇ 122017	SCREW, 5/16-18X1.00 HHC GR2	2
67	446363	WASHER, FLAT .375X .88X.082	4
68	◇ 1498	NUT, 5/16-18 REGHEXCTRLK	2
69	55021	EDGING	75"
70	324695	OPERATOR'S MANUAL ENGLISH	1
71	324698	PARTS MANUAL ENGLISH	1

◇ Indicates STANDARD HARDWARE ITEMS.

39" LAWN TRACTOR MODEL C3560-070

MOWER SUSPENSION ASSEMBLY

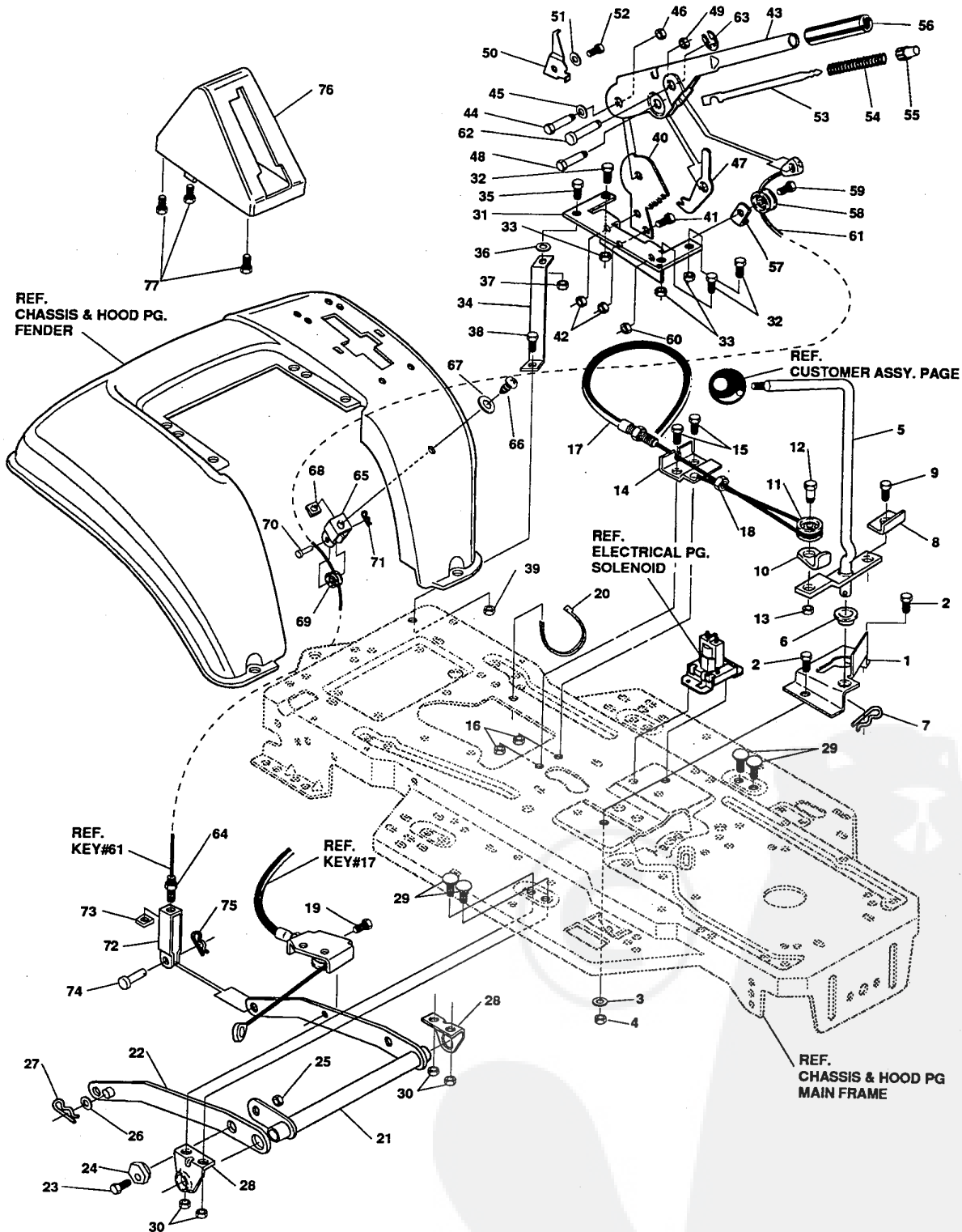

NOTE: ALWAYS USE ORIGINAL EQUIPMENT PARTS. Use of service/replacement parts other than original equipment parts may void your warranty.

ALL UNNUMBERED ITEMS ARE INTERCHANGEABLE WITH OPPOSITE SIDE

321271C

39" LAWN TRACTOR MODEL C3560-070

key#	part#	description	qty.
1	320075-853	BRACKET,CLUT-ENGAGELEVER	1
2	180079	◇ SCREW, 5/16-18X1.00 HHC	2
3	120393	WASHER, FLAT .344X .69X.065	2
4	1498	◇ NUT, 5/16-18 REGHEXCTRLK	2
5	303063-953	ASSY,CLUTCH LEVER	1
6	50148	BEARING,FL. .503IDX.628OD	1
7	8260	PIN, HAIR .091 DIA X1.66LG	1
8	300699-953	BRACKET,SWITCH ENGAGE	1
9	35498	◇ SCREW, 5/16-18X .75 WAHHTAP	1
10	300699-953	BRKT,CABLE RETAINER	1
11	48306	PULLEY, .906X.305 PM	1
12	58336	BOLT, .375X .375 HHS 1/4-20	1
13	1502	◇ NUT, 1/4-20 REGHEXCTRLK	1
14	300698-853	BRKT, FRAME CABLE	1
15	180020	◇ SCREW, 1/4-20X .75 HHC	2
16	1502	◇ NUT, 1/4-20 REGHEXCTRLK	2
17	301503	ASSY,CABLE, BLADE ENGAGE	1
18	120613	◇ NUT, 1/4-28 HJAM	1
19	35498	◇ SCREW, 5/16-18X .75 WAHHTAP	1
20	57444	TIE, CABLE BLACK NYLON	1
21	300158-853	ASSY,REAR LIFT	1
22	300169-853	ASSY.LINK,RIGHT SIDE	1
23	180079	◇ SCREW, 5/16-18X1.00 HHC	1
24	58247	ADJUSTING NUT	1
25	1498	◇ NUT, 5/16-18 REGHEXCTRLK	1
26	417098	WASHER, FLAT .531X1.06X.095	2
27	8260	PIN, HAIR .091 DIA X1.66LG	2
28	58248-853	BRKT,REAR,HANG,SUSP.	2
29	126211	BOLT, 5/16-18X .63 CARR	4
30	1498	◇ NUT, 5/16-18 REGHEXCTRLK	4
31	58333	BRACKET,HGT/ADJUST SUPPORT	1
32	180077	◇ SCREW, 5/16-18X .75 HHC	3
33	1498	◇ NUT, 5/16-18 REGHEXCTRLK	3
34	* 300336-860	BRACE, FENDER F-5 SUS	1
35	180079	◇ SCREW, 5/16-18X1.00 HHC	1
36	45602	WASHER, FLAT .333X .87X.119	1
37	1498	◇ NUT, 5/16-18 REGHEXCTRLK	1
38	180079	◇ SCREW, 5/16-18X1.00 HHC	1
39	1498	◇ NUT, 5/16-18 REGHEXCTRLK	1
40	301238	QUADRANT,HEIGHT ADJUST	1
41	180077	◇ SCREW, 5/16-18X .75 HHC	2
42	1498	◇ NUT, 5/16-18 REGHEXCTRLK	2
43	322292-853	HANDLE,LIFT SHORT BLK	1
44	300171	BOLT, .500X .270 HHS 5/16-18	1
45	996418	WASHER, FLAT .506X .75X.024	1
46	44108	◇ NUT, 5/16-18 HWDFLCTRLK	1
47	301239	PAWL, HEIGHT ADJUST	1
48	300171	BOLT, .500X .270 HHS 5/16-18	1
49	44108	◇ NUT, 5/16-18 HWDFLCTRLK	1
50	300782-953	POINTER Z-PL	1
51	138479	WASHER, EXLK.195X.41X.03	1
52	35287	◇ SCREW, #8-32X .38 HHWAT	1
53	303027	ROD,ACTUATOR-SHORT	1
54	58326	SPRING, HEIGHT ADJUST	1
55	58325	KNOB, HGT ADJ PUSH BUTTON	1
56	58329	GRIP .750 OD W/ HOLE	1
57	58335-953	BRKT, CABLE RETAIN	1
58	39298	PULLEY, .906X.305 NYLON	1
59	58336	BOLT, .375X .375 HHS 1/4-20	1
60	1502	◇ NUT, 1/4-20 REGHEXCTRLK	1
61	300341	CABLE, LIFT 21.70 F-5 20X8-8	1
62	300310	PIN,CLEVIS .310DIA+.475LG	1
63	300311	RING, RET E .31X.24	1
64	120375	◇ NUT, 1/4-20 REGHEX	1
65	300298-953	CLEVIS	1
66	120228	◇ SCREW, 5/16-18X .63HHC	1
67	301551	WASHER,.344IDX1.50DX.09 CU BPH	1
68	120373	◇ NUT, 5/16-18 SQ	1
69	39298	PULLEY, .906X.305 NYLON	1
70	300317	PIN, CLEVIS .38 DIA X1.00 LG	1
71	8260	PIN, HAIR .091 DIA X1.66LG	1
72	300703-953	CLEVIS, LIFT CABLE	1
73	120372	◇ NUT, 1/4-20 REGSQ	1
74	39522	PIN CLEVIS .312 X .812	1
75	121222	PIN, COTTER .090/.086X.75LG	1
76	300335	LIFT COVER-39" F5	1
77	300340	◇ SCREW, #10 X .75 HHPLAST	3

◇ STANDARD HARDWARE ITEMS.

39" LAWN TRACTOR MODEL C3560-070

STEERING ASSEMBLY

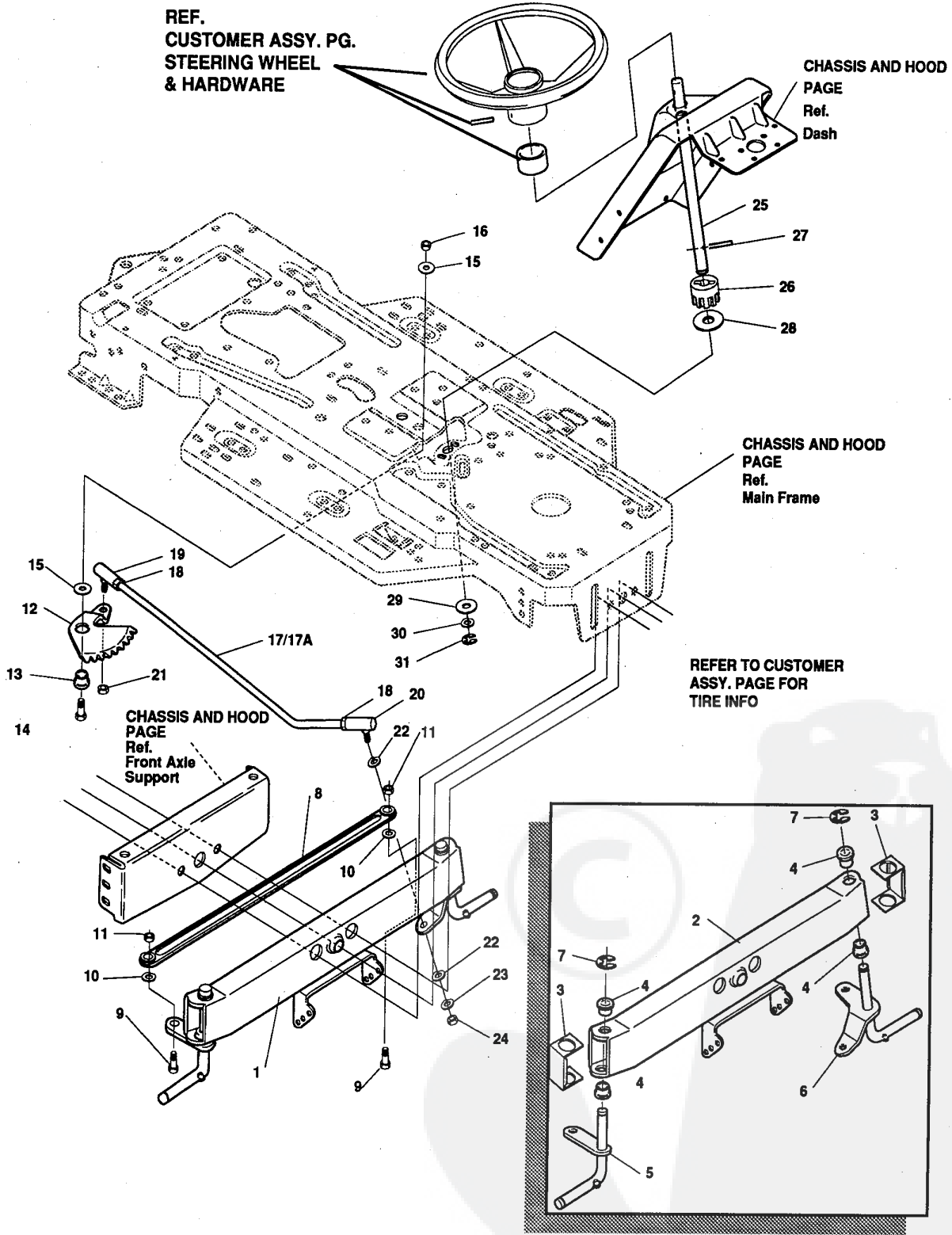

NOTE: ALWAYS USE ORIGINAL EQUIPMENT PARTS. Use of service/replacement parts other than original equipment parts may void your warranty.

ALL UNNUMBERED ITEMS ARE INTERCHANGEABLE WITH OPPOSITE SIDE

315650E

39" LAWN TRACTOR MODEL C3560-070

key#	part#	description	qty.
1.	*	ASSY,AXLE FRONT	1
2.	300272	ASSY FRONT AXLE SUSPENDED	1
3.	53373	AXLE COVER	2
4.	52407	SPINDLE BEARING	4
5.	302926	ASSY,SPINDLE RH	1
6.	315886	ASSY,SPINDLE LH	1
7.	36625	RING, RETEX .57X.05TRU5133-75	2
8.	304590	TIE ROD ASSY 19.81LG W-SECTION	1
9.	• 180128	SCREW, 3/8-16X1.75 HHC	2
10.	120382	WASHER, REGSPTLK.393X.68X.10	2
11.	• 1499	NUT, 3/8-16 REGHXCTRLK	2
12.	58289	SECTOR, STEERING LF	1
13.	52406	BRNG,FL ECC.510IDX .998ODX .56	1
14.	• 180177	SCREW, 1/2-13X1.50 HHC	1
15.	22265	WASHER, FLAT .515X1.38X.119PL	2
16.	• 1500	NUT, 1/2-13 REGHCTRLK	1
17.	58291	STEERING LINK	1
18.	• 124925	NUT, 3/8-24 REGHEXJAM	2
19.	57158	BALL JOINT 3/8 THD SHORT STUD	1
20.	21275	BALL JOINT 3/8 TH'D LONG STUD	1
21.	• 46692	NUT, 3/8-24 WDFLHLK WHIZ	1
22.	996416	WASHER, FLAT .391X1.00X.125	2
23.	120382	WASHER, REGSPTLK.393X.68X.10	1
24.	• 120369	NUT, 3/8-24 REGHEX	1
25.	58243	SHAFT, STEERING LF	1
26.	58244	PINION, STEERING LF	1
27.	58274	PIN,DOWEL .2500 OD+1.75LG PL	1
28.	301410	BRNG, FL .752IDX1.061ODX .24	1
29.	301398	WASHER, FORMED1.135X1.53X.12	1
30.	21682	WASHER, FLAT .765X1.25X.042	1
31.	36625	RING, RETEX .57X.05TRU5133-75	1

* ORDER INDIVIDUAL PARTS.
 • STANDARD HARDWARE ITEMS

39" LAWN TRACTOR MODEL C3560-070

MOTION DRIVE ASSEMBLY

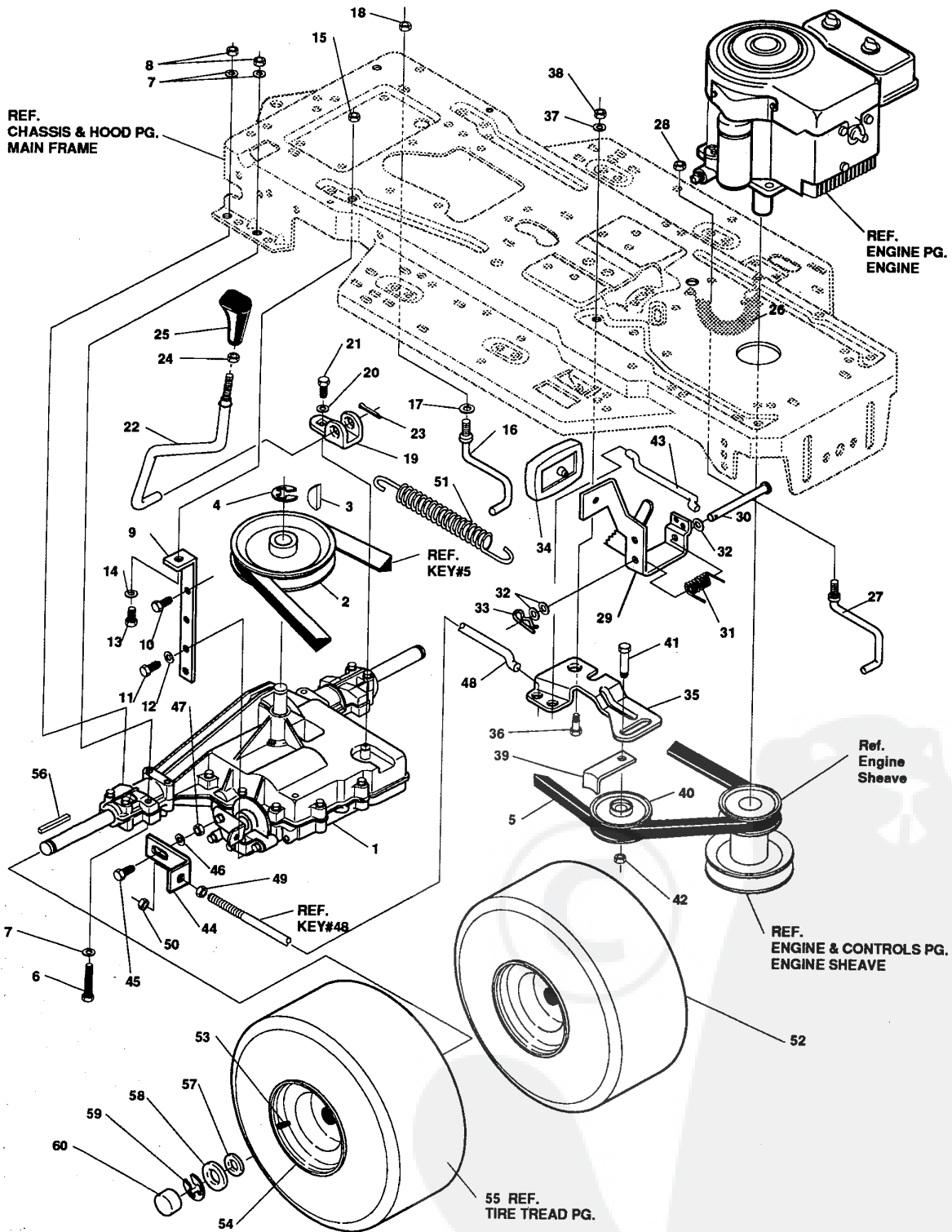

NOTE: ALWAYS USE ORIGINAL EQUIPMENT PARTS.
Use of service/replacement parts other than original equipment parts may void your warranty.

**ALL UNNUMBERED
ITEMS ARE INTERCHANGEABLE
WITH OPPOSITE SIDE**

317830E

39" LAWN TRACTOR MODEL C3560-070

key#	part#	description	qty.
1	*	TRANSAXLE PEERLESS	1
2	302745	PULLEY,V 4L 6.60 OD	1
3	3021	KEY, WDRF 606 .750X.187X.312	1
4	22053	RING, RETEX .58X.04TRU5100-62	1
5	314120	BELT	1
6	◇180089	SCREW, 5/16-18X2.25 HHC	4
7	120393	WASHER, FLAT .344X .69X.065	8
8	◇1498	NUT, 5/16-18 REGHEXCTRLK	4
9	323471	STABILIZER BRKT	1
10	◇50947	SCREW, 3/8-16X1.25 WAHTAP	1
11	◇35498	SCREW, 5/16-18X .75 WAHTAP	1
12	120638	WASHER, HVSP TLK .328X.60X.09	1
13	◇122017	SCREW, 5/16-18X1.00 HHC	1
14	120393	WASHER, FLAT .344X .69X.065	1
15	◇1498	NUT, 5/16-18 REGHEXCTRLK	1
16	57259	GUIDE, BELT 5/16-18THD	1
17	138538	WASHER, REGINTLK.320X.61X.03	1
18	◇1498	NUT, 5/16-18 REGHEXCTRLK	1
19	310754-955	BRKT,SHIFT	1
20	57157	WASHER, .750X.250 SP-TRANSAXLE	1
21	◇56255	SCREW, 1/4-28X .75 NYLHHC	1
22	57169	LEVER, SHIFT	1
23	137185	PIN, COTTER .125 DIAX1.00	1
24	◇120238	NUT, 1/2-13 HEXJAM	1
25	304438	KNOB,SHIFT NOMA 1/2-13	1
26	321514	SPRING BIAS DRAGLINK	1
27	304016	GUIDE,BELT	1
28	1498	NUT, 5/16-18 REGHEXCTRLK	1
29	300308	PEDAL ASSY,BRAKE/CLUTCH	1
30	319675	PIN CLEVIS	1
31	57847	SPRING, BRAKE PEDAL	1
32	2968	WASHER, FLAT .504X .75X.059	3
33	56180	PIN,HAIR	1
34	48160	PAD, CLUTCH BRAKE	1
35	300154	ARM,IDLER TRACTION DR.	1
36	300793	BOLT, .625X .135 HSH 5/16-18	1
37	45602	WASHER, FLAT .333X .87X.119	1
38	◇1498	NUT, 5/16-18 REGHEXCTRLK	1
39	39659	RETAINER, STRAP BELT	1
40	35374	PULLEY, IDLER	1
41	45892	BOLT, 3/8-16X1.50 CARR	1
42	◇1499	NUT, 3/8-16 REGHXCTRLK	1
43	57204	ROD, CLUTCH	1
44	57217	BRACKET, BRAKE ROD	1
45	20507	BOLT, .437X .156 HSH 5/16-18	1
46	45602	WASHER, FLAT .333X .87X.119	1
47	◇1498	NUT, 5/16-18 REGHEXCTRLK	1
48	313659	ROD, BRAKE	1
49	◇271184	NUT, 5/16-18 HEXKEPS	1
50	◇1498	NUT, 5/16-18 REGHEXCTRLK	1
51	56359	SPRING, CLUTCH .113X.750X8.75	1
52	~	TIRE & RIM, PU 20X8.00	2
53	24167	VALVE STEM	1
54	57165	WHEEL 20X8.00 WHITE	1
55		REFER TO TIRE TREAD PAGE	1
56	52928	KEY, SQUARE .187SQX2.25	2
57	642	WASHER, FLAT .755X1.31X.075	4
58	42815	WASHER, FLAT .755X1.53X.07	2
59	36625	RING, RETEX .57X.05TRU5133-75	2
60	40394	CAP, 1.500ID X 7/8LG HUB	2

◇ Indicates STANDARD HARDWARE ITEMS.

* CONTACT YOUR NEAREST TRANSAXLE DEALER FOR PARTS & SERVICE.

~ ORDER INDIVIDUAL PARTS.

39" LAWN TRACTOR MODEL C3560-070

ENGINE & CONTROL ASSEMBLY

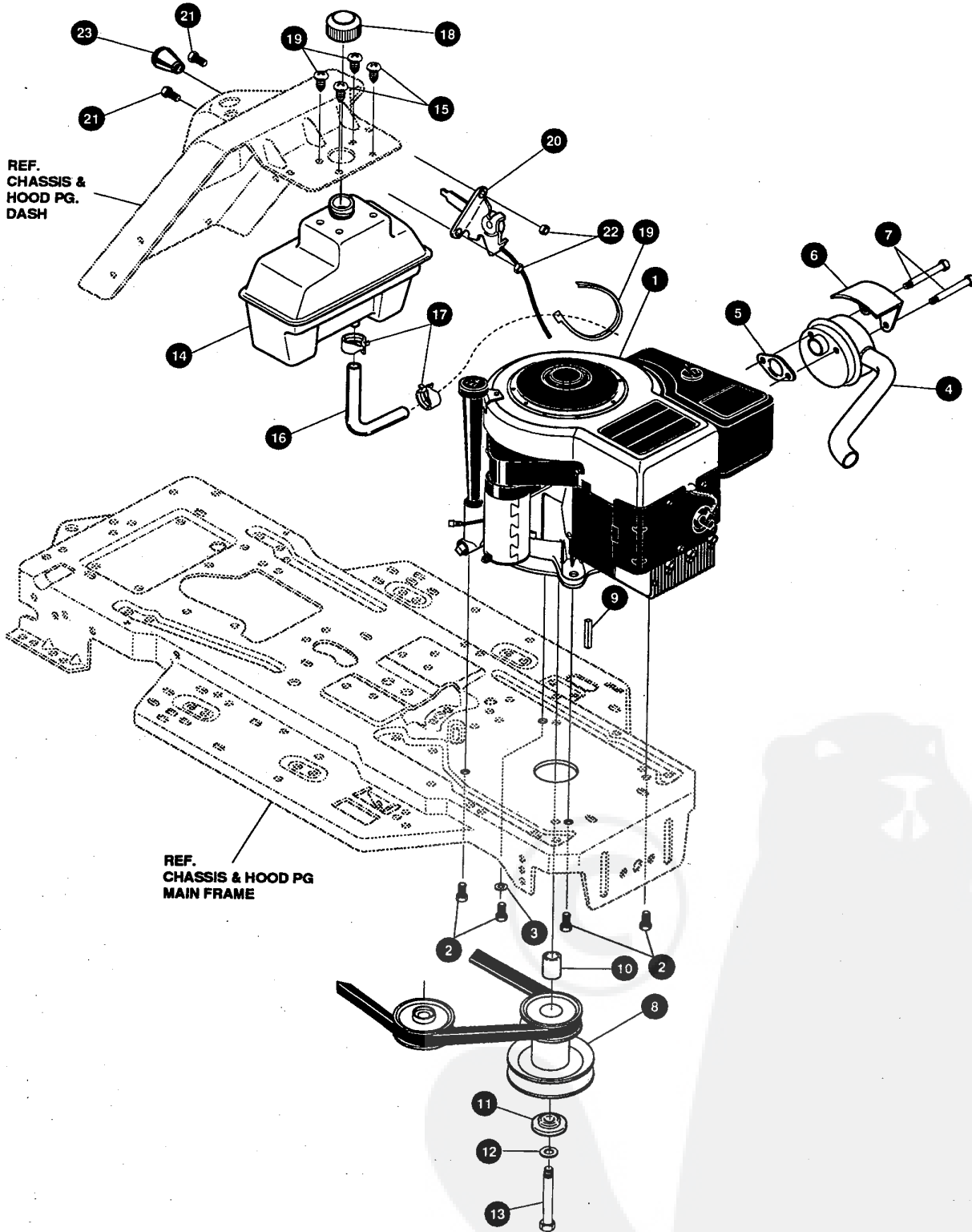

NOTE: ALWAYS USE ORIGINAL EQUIPMENT PARTS.
Use of service/replacement parts other than original equipment parts may void your warranty.

**ALL UNNUMBERED
ITEMS ARE INTERCHANGEABLE
WITH OPPOSITE SIDE**

322571B

39" LAWN TRACTOR MODEL C3560-070

key#	part#	description	qty.
1	ENGINE	12.5 HP B&S I/C (SEE ENGINE MANUAL)	1
2	50947	SCREW, 3/8-16X1.25 WAHTAP	4
3	138489	WASHER, EXLK .384X.69X.04	1
4	305367	MUFFLER, LO-TONE EXPORT	1
5	46708	GASKET, MUFFLER	1
6	54767	SHIELD, HEAT, FOR ROUND MUFFLER	1
7	• 173063	SCREW, 5/16-18X3.50 HHC	2
8	58361	PULLEY ASSY, 4.75 OFFS 5.5DIA	1
9	57791	KEY, SQUARE .250SQX5.00	1
10	304246	SPACER, 1.01X1.484 ENGIN PULLEY	1
11	56431	WASHER, .980DX1.380DX.437PILOT	1
12	120383	WASHER, REGSPTLK.459X.78X.12	1
13	428644	SCREW, 7/16-20X5.00 HHC	1
14	314989	FUEL TANK	1
15	• 49050	SCREW, 1/4-10X.75	4
16	47452	GAS LINE	13"
17	48672	CLAMP, FUEL LINE	2
18	46704	GAS CAP 1-1/2-7 THD	1
19	57444	WIRE TIE	1
20	321273	CONTROL THROTTLE	1
21	• 320553	SCREW, 10-24X.50 SLHHMA	2
22	• 271166	NUT, #10-24 HEXKEPS	2
23	50607	KNOB, ROUND THROTTLE	1

• STANDARD HARDWARE ITEMS.

39" LAWN TRACTOR MODEL C3560-070

PRE-PAINTED DECK

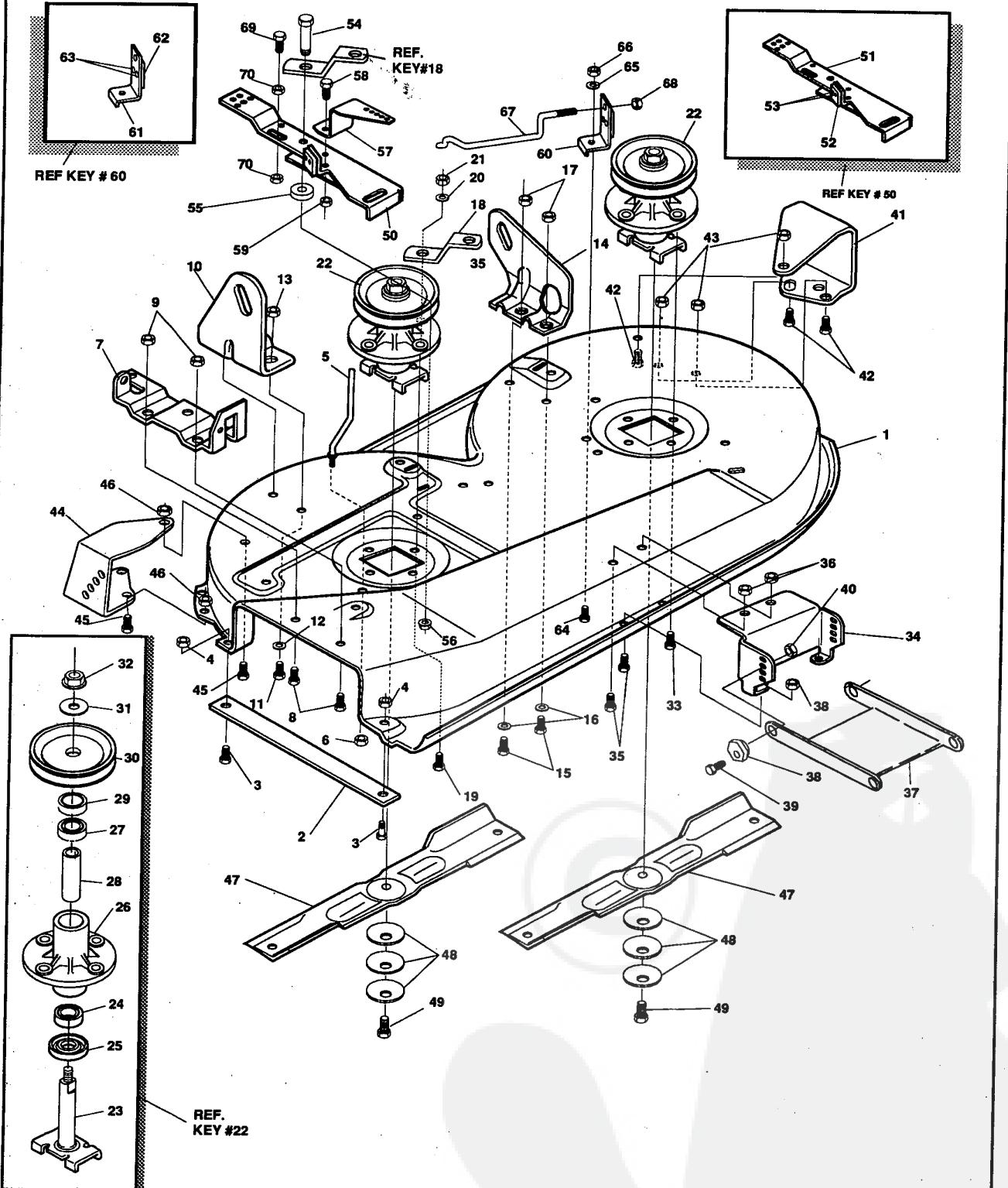

NOTE: ALWAYS USE ORIGINAL EQUIPMENT PARTS. Use of service/replacement parts other than original equipment parts may void your warranty.

ALL UNNUMBERED ITEMS ARE INTERCHANGEABLE WITH OPPOSITE SIDE

316186A

39" LAWN TRACTOR MODEL C3560-070

Key#	Part#	Description	Qty.
1	315610-173	DECK,39"SD MOWER	1
2	57314	BAR, SKID	1
3	126216	BOLT, 5/16-18X .75 CARR	2
4	◇ 1498	NUT, 5/16-18 REGHEXCTRLK	2
5	57318	GUIDE, BELT 5/16-18 THD	1
6	◇ 1498	NUT, 5/16-18 REGHEXCTRLK	1
7	57360	BRACKET, CHUTE	1
8	◇ 120834	SCREW, 5/16-18X .50 HHC	2
9	◇ 1498	NUT, 5/16-18 REGHEXCTRLK	2
10	58250	LIFT BRACKET, REAR,RH	1
11	◇ 180077	SCREW, 5/16-18X .75 HHC	2
12	120393	WASHER, FLAT .344X .69X.065	2
13	◇ 1498	NUT, 5/16-18 REGHEXCTRLK	2
14	58251	BRACKET,DECK LIFTREAR LH	1
15	◇ 180077	SCREW, 5/16-18X .75 HHC	2
16	120393	WASHER, FLAT .344X .69X.065	2
17	◇ 1498	NUT, 5/16-18 REGHEXCTRLK	2
18	315302	BRACKET, IDLER SUPPORT	1
19	◇ 300345	SCREW, 5/16-18X1.38 WATAP	1
20	120393	WASHER, FLAT .344X .69X.065	1
21	◇ 1498	NUT, 5/16-18 REGHEXCTRLK	1
22	56424	QUILL ASSY, 36/39/40/43	2
23	56425	SHAFT/SADDLE 36"	1
24	49562	BRNG, BALL	1
25	50616	DUST SHIELD	1
26	55547	QUILL CASTING	1
27	49562	BRNG, BALL	1
28	50818	SPACER,3.797LGX.669IDX.88OD	1
29	51449	SPACER, 438LGX.932ODX.672ID-PM	1
30	56390	PULLEY,26/36" QUILL	1
31	56365	SPECIAL WASHER	1
32	◇ 1282	NUT, 7/16-20 WDFLLK	1
33	◇ 50634	SCREW, 5/16-18X .88 WAHTAP	7
34	58315	LIFT SUPPORT FRONT DECK	1
35	◇ 180075	SCREW, 5/16-18X .63 HHC	4
36	◇ 1498	NUT, 5/16-18 REGHEXCTRLK.	4
37	58305	LINK BRACKET,DECK FR	1
38	58247	ADJUSTING NUT	2
39	◇ 122017	SCREW, 5/16-18X1.00 HHC	2
40	◇ 1498	NUT, 5/16-18 REGHEXCTRLK	2
41	300103	WHEEL BRKT, LH	1
42	◇ 180075	SCREW, 5/16-18X .63 HHC	3
43	◇ 1498	NUT, 5/16-18 REGHEXCTRLK	3
44	300102	WHEEL BRKT, RH	1
45	◇ 180075	SCREW, 5/16-18X .63 HHC	3
46	◇ 1498	NUT, 5/16-18 REGHEXCTRLK	3
47	57299	BLADE, 39" STD-LIFT 19.5	2
48	2483	WASHER,.39IDX1.25DX.07 BELLVIL	6
49	◇ 39573	SCREW, 3/8-24X1.00 NYLHHC	2
50	320565	IDLER ARM ASSY.	1
51	300490	IDLER ARM	1
52	306973	BRAKE PAD	1
53	135624	RIVET,TRSET .185 DIAx.41	2
54	300180	BOLT,.50 X .188 HHSH3/8-16	1
55	996416	WASHER,FLAT .391 X 1.— X .125	1
56	45171	NUT,5/16-18 X .75 HHC WHIZ-LOCK	1
57	300700	BRACKET EXTENSION IDLER	1
58	180077	SCREW,5/16-18 X .75 HHC	1
59	1498	NUT, 5/16-18 REGHEXCTRLK	1
60	303247	ASSY BLADE BRAKE	1
61	303246	BRAKE ARM	1
62	306973	BRAKE PAD	1
63	135624	RIVET,TRSET .185 DIAx.41	2
64	120228	SCREW,5/16-18X.63 HHC	1
65	120393	WASHER,FLAT .344 X .69 X. 65	1
66	1498	NUT, 5/16-18 REGHEXCTRLK	1
67	300316	ROD,BRAKE	1
68	1502	NUT,1/4-20 REGHEXCTRLK	1
69	121954	SCREW,1/4-20X2.00 HHC	1
70	271172	NUT,1/4-20 REGHEXKEPS	2

◇ Indicates STANDARD HARDWARE ITEMS

39" LAWN TRACTOR MODEL C3560-070

FINAL DECK ASSEMBLY

SEE DWG. 316186 FOR PART ASSEMBLY
OF PAINTED DECK

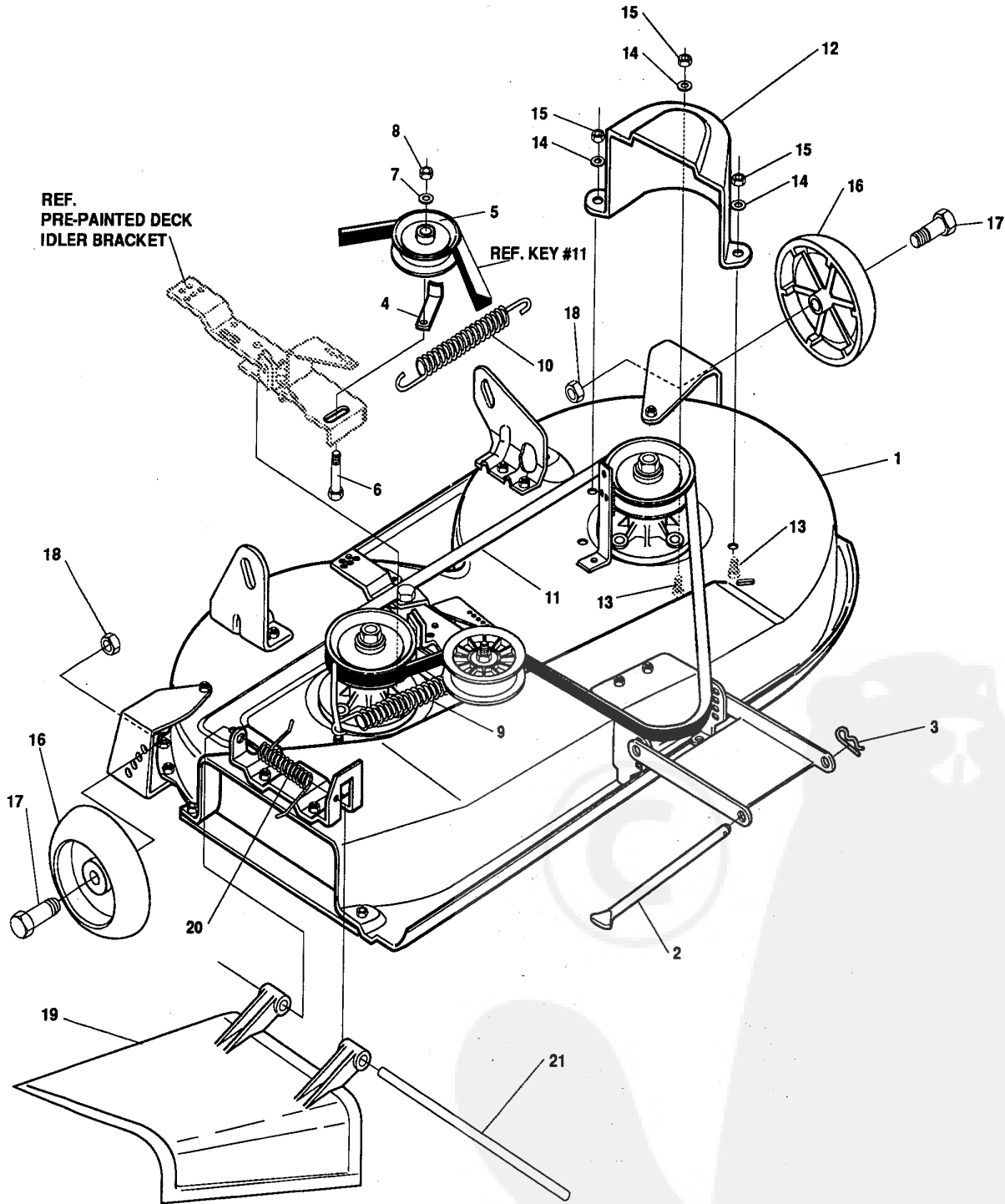

NOTE: ALWAYS USE ORIGINAL EQUIPMENT PARTS.
Use of service/replacement parts other than original equipment parts may void your warranty.

**ALL UNNUMBERED
ITEMS ARE INTERCHANGEABLE
WITH OPPOSITE SIDE**

316198A

39" LAWN TRACTOR MODEL C3560-070

Key#	Part#	Description	Qty.
1.	*	DECK,ASSY 39"SD SUS	1
2.	58306	ROD, DECK HITCH	1
3.	8260	PIN, HAIR .091 DIA X 1.66LG	1
4.	300844-953	RETAINER,BELT	1
5.	303030	PULLEY, IDLER BFF	1
6.	57325	BOLT, 3/8-16 X 2.00 CARR	1
7.	120382	WASHER, REGSPTLK.393X.68X.10	1
8.	• 120377	NUT, 3/8-16 REGHX	1
9.	322064	SPRING .071 X .62 X 4.37	1
10.	300473	SPRING,TENSION	1
11.	300680	BELT, V 5L 77.75 KEVLAR	1
12.	302833	GUARD, BELT LH PLASTIC	1
13.	• 120228	SCREW, 5/16-18 X .63 HHC	3
14.	120393	WASHER, FLAT .344X .69X.065	3
15.	• 1498	NUT, 5/16-18 REGHEXCTRLK	3
16.	302611	WHEEL, SD 6.000DX1.38WD	2
17.	23763	BOLT, .500X1.390 HSH 3/8-16	2
18.	• 1499	NUT, 3/8-16 REGHXCTRLK	2
19.	57818	CHUTE-36SD,39SD,45SD	1
20.	314975	SPRING TORSION CHUTE DEF.	1
21.	57317	PIVOT ROD,CHUTE	1

• Indicates STANDARD HARDWARE ITEMS.
 * ORDER INDIVIDUAL PARTS.

39" LAWN TRACTOR MODEL C3560-070

ELECTRICAL ASSEMBLY

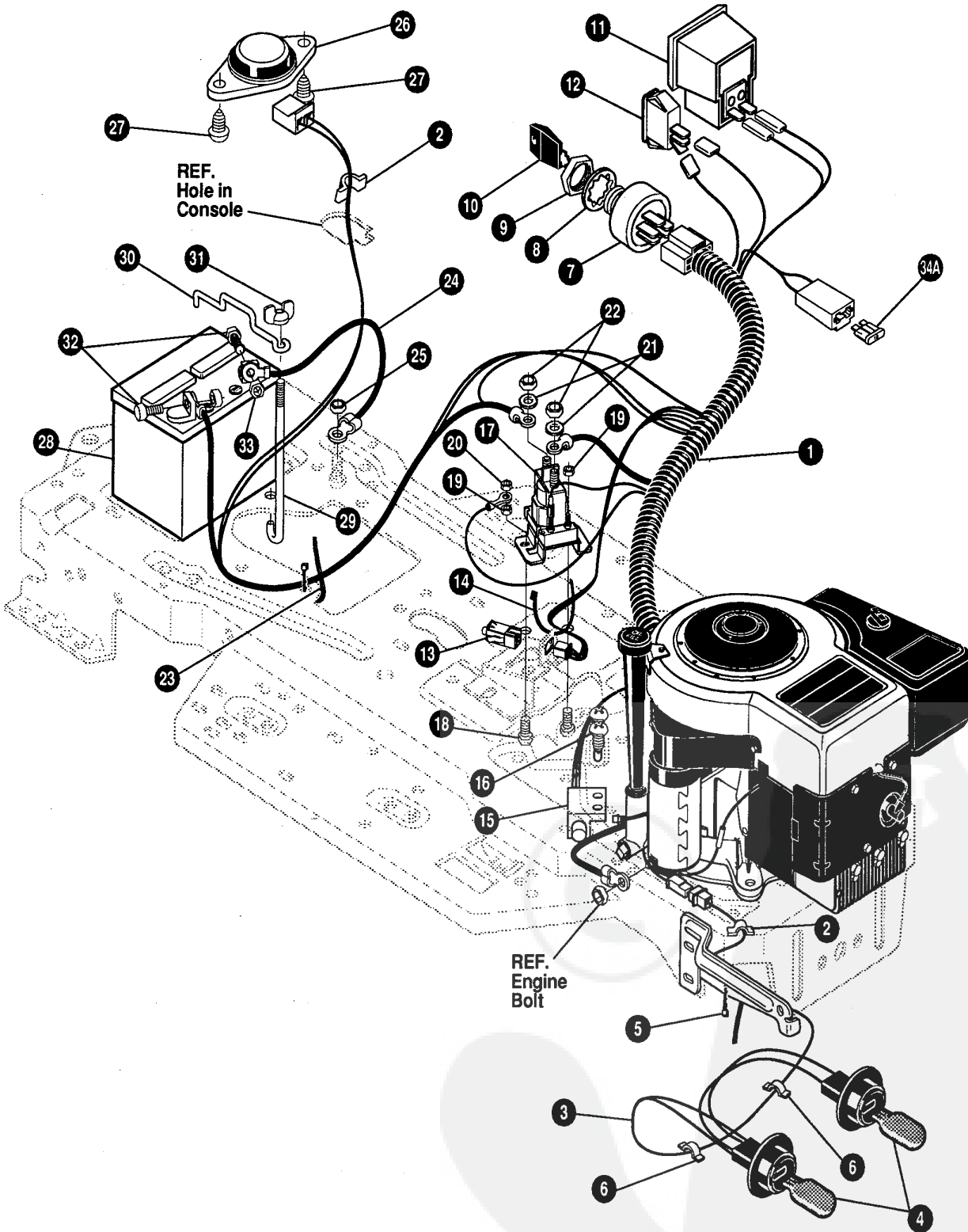

NOTE: ALWAYS USE ORIGINAL EQUIPMENT PARTS.
 Use of service/replacement parts other than original equipment parts may void your warranty.

**ALL UNNUMBERED
 ITEMS ARE INTERCHANGEABLE
 WITH OPPOSITE SIDE**

320173A

39" LAWN TRACTOR MODEL C3560-070

Key#	Part#	Description	Qty.
1	320065	HARNESS, 12-12.5 BS, H10, WRAP,LF	1
2	41482	PRESS, CLIP	2
3	303064	ASSY, LIGHT WIRE-1/4 TURN	1
4	52572	BULB, HEADLIGHT	2
5	57444	TIE, CABLE	1
6	41482	PRESS, CLIP	2
7	305720	SWITCH-IGN	1
8	138557	WASHER, REGINTLK .640X1.1X.05	1
9	48140	NUT, 5/8-32 HXHD IGN SWIT	1
10	300626	KEY, IGNITION	1
11	300133	AMMETER	1
12	300334	LIGHT SWITCH, ON/OFF PANEL	1
13	320082	SWITCH, DOUBLE POLE	1
14	57444	TIE, CABLE	1
15	57476	SWITCH, SCR MNT	1
16	●57220	SCREW, #12 X.50 PHPNTAP	2
17	53716	SOLENOID	1
18	●187745	SCREW, 1/4-20 REGHEXCTRLK	2
19	●1502	NUT, 1/4-20 REGHEXCTRLK	2
20	●271172	NUT, 1/4-20 REGHEXKEPS	1
21	138485	WASHER, EXLK .320X.61X.03	2
22	120368	NUT, 5/16-24 REGHEX	2
23	57444	TIE, CABLE	1
24	55511	WIRE, GROUND, 12.5"	1
25	271184	NUT, 5/16-18 HEXKEPS	1
26	57547	SWITCH, SEAT	1
27	●160505	SCREW, 1/4-20X.38	2
28	57486	BATTERY 12V 5-PLATE/18 AMP	1
29	57551	ROD, BATTERY	1
30	57552	ROD, BATTERY TOP	1
31	310067	NUT, WING 1/4-20X.63 HHC	1
32	●120854	SCREW, 1/4-20 X.63 HHC	2
33	●271172	NUT, 1/4-20 REGHEXKEPS	2
34A	●●302031	FUSE, 15 amp SPADE TYPE	1

.. SPADE TYPE FUSE INCLUDED WITH THE WIRE HARNESS
 ●STANDARD HARDWARE ITEMS

SCHEMATIC DRAWING:

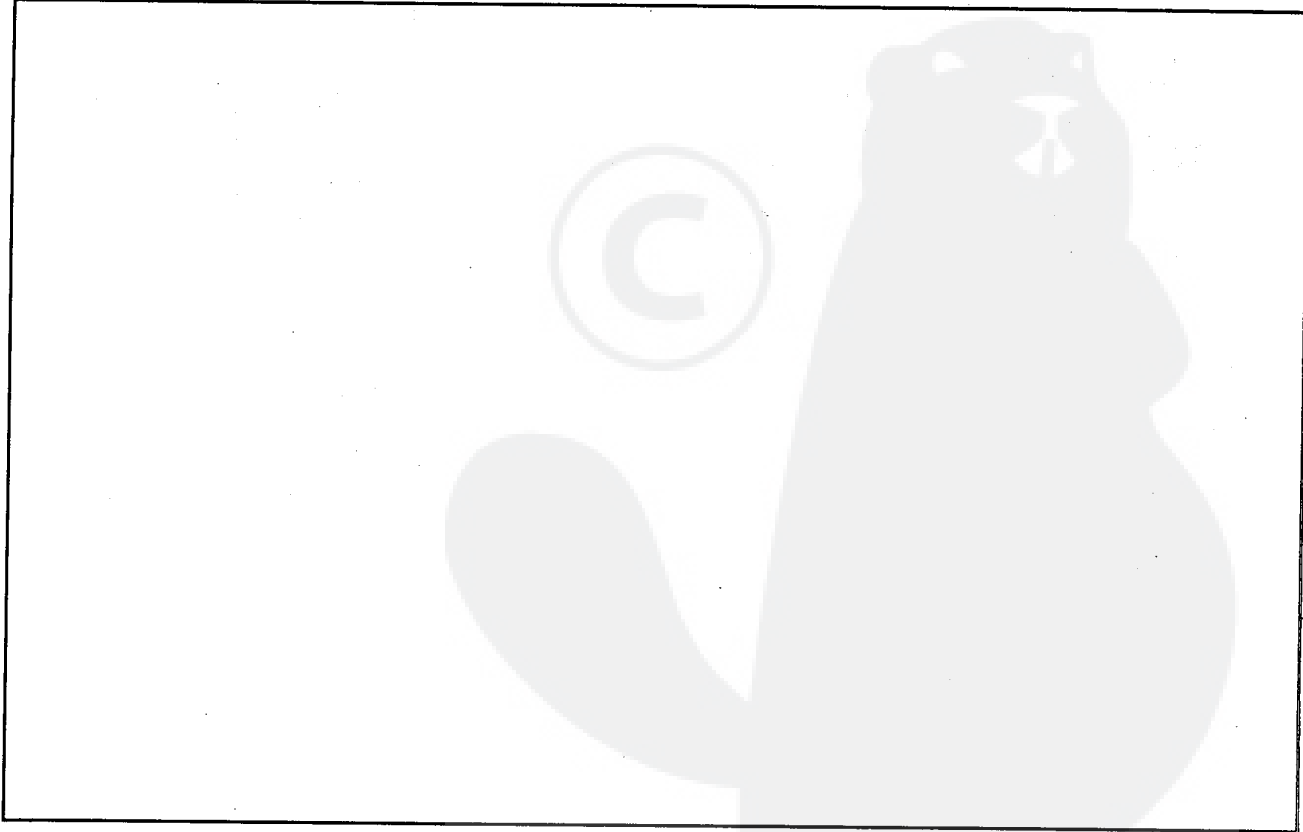

39" LAWN TRACTOR MODEL C3560-070

DECALS

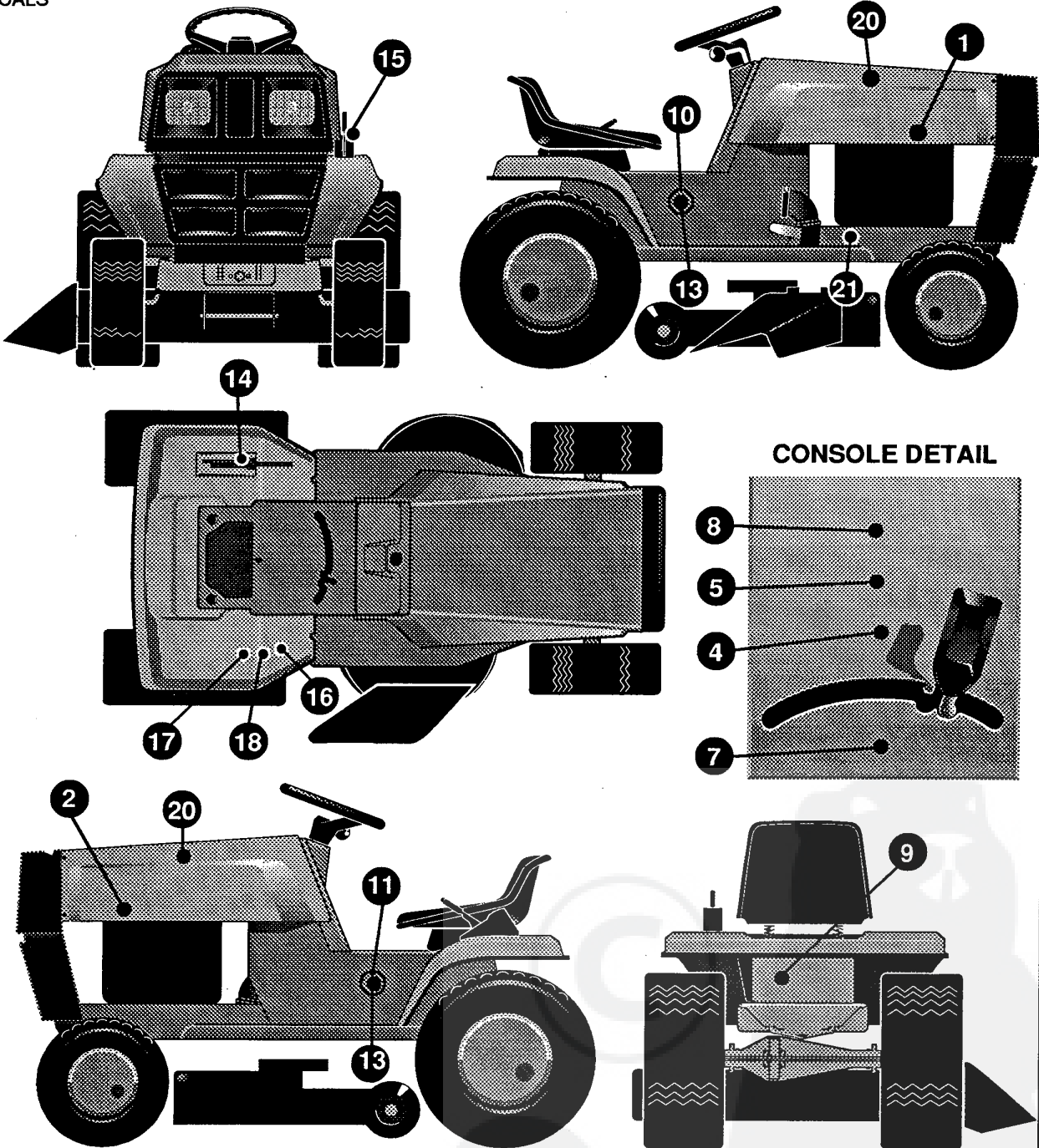

322438A

39" LAWN TRACTOR MODEL C3560-070

key#	part#	description	qty.
1.	314456	DECAL, HOODSIDE, RH H-21	1
2.	314457	DECAL, HOODSIDE, LH H-21	1
3.	321765	DECAL, LF DASH, PTO/LIGHT SW EXP	1
4.	69524	DECAL, INSTRUCT CONSOLE TOP GER	1
5.	69525	DECAL, INSTRUCT CONSOLE TOP FR	1
6.		REFERENCE ONLY	1
7.	301104	DECAL, CONSOLE TOP SHIFT 5-SP	1
8.	307383	DECAL, INSTR. CONSOLE TOP ENGL	1
9.	310436	DECAL, FRENCH SAFETY CERT.	1
10.	314462	DECAL, CONSOLE RH LARGE FRAME	1
11.	314463	DECAL, CONSOLE LH LARGE FRAME	1
12.		REFERENCE ONLY	1
13.	316298	NAMEPLATE 12.5/39 WHITE	2
14.	68901	DECAL, BLADE HEIGHT ADJ. EUROPE	1
15.	301897	DECAL, LIFT DECK BLADE HEIGHT	1
16.	305770	DECAL, CAUTION TRIANGLE, EUROPE	1
17.	68902	DECAL, WARNING, FRENCH/GERMAN	1
18.	310553	DECAL, DANGER, ENGLISH	1
19.	55835	PAD, FOAM HOOD TOP H-6/7	1
20.	55836	PAD, FOAM HOOD SIDE H-6/7	2
21.	68903	DECAL, BRAKE/CLUTCH EUROPE	1

39" LAWN TRACTOR MODEL C3560-070

CUSTOMER ASSEMBLY

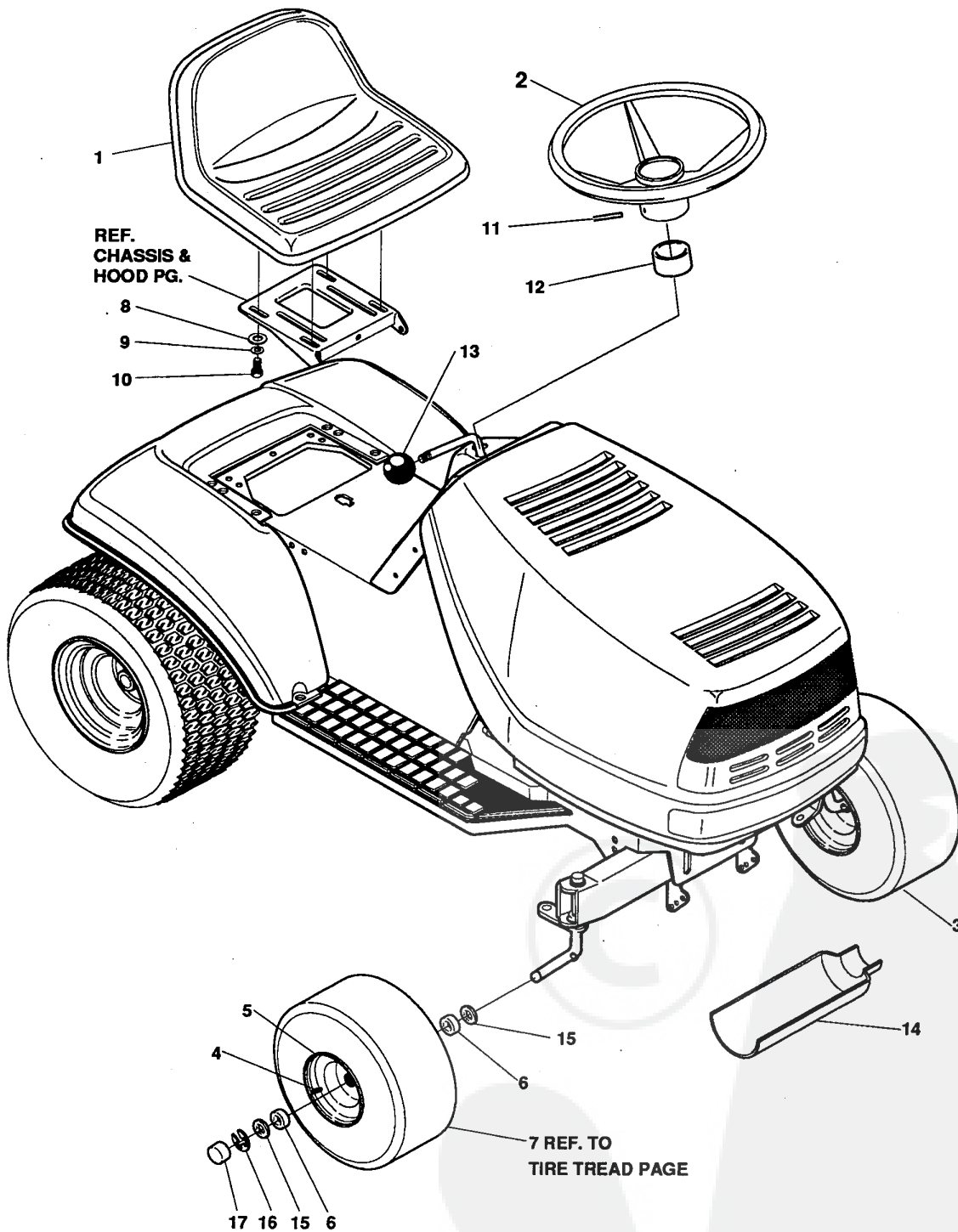

316185C

39" LAWN TRACTOR MODEL C3560-070

CUSTOMER ASSEMBLY VIEW

315857 PARTS BAG ASSY QTY1

key#	part#	decription	qty
1	57454	SEAT,450 MICH.	1
2	301251	WHEEL, STEERING, 13"	1
3	*	TIRE & RIM, PU 15X6.0X6 TURF	2
4	24167	VALVE STEM	1
5	39829	WHEEL W/BRG.	1
6	39979	BEARING,FL1.38OD+.753ID PM	2
7		REFER TO TIRE TREAD PAGE	
8	120393	WASHER, FLAT .344X .69X.065	4
9	120638	WASHER, HVSP TLK .328X.60X.09	4
10	122007	SCREW, 5/16-18X .75 HHC	4
11	456378	PIN, SPRING.250DIAX2.00LG HVPL	1
12	57212	COVER, STEERING SHAFT	1
13	55514	SHIFT KNOB	1
14	54873	TROUGH, OIL DRAIN	1
15	642	WASHER, FLAT .755X1.31X.075	4
16	36625	RING, RETEX .57X.05TRU5133-75	2
17	40394	CAP, 1.500ID X 7/8LG HUB	2

*ORDER INDIVIDUAL PARTS.

TREAD PATTERNS

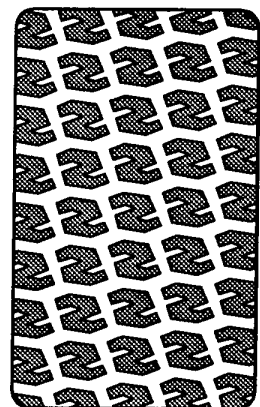
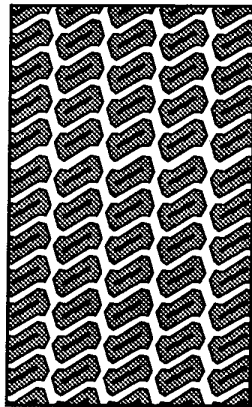
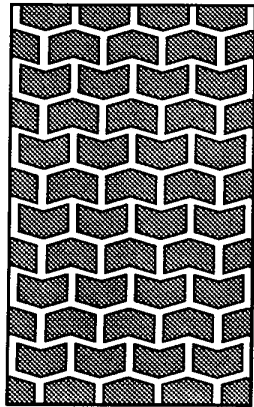
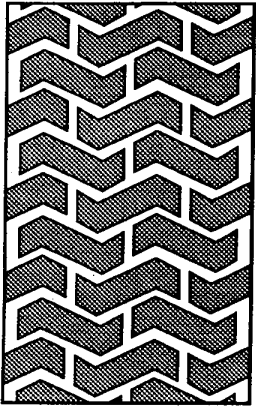

"A"

"B"

"C"

"D"

TIRE SIZE

TIRE SIZE	"A"	"B"	"C"	"D"
11 X 4.00 - 5	42295	319679		
13 X 5.00 - 6	41060	319680		
15 X 6.00 - 6	39830	316702	301140	313952
16 X 6.50 - 8	41081	319682		314539
18 X 8.50 - 8	319683	317400		
18 X 9.50 - 8	41106	316701		313950
20 X 8.00 - 8	319685	319684	57164	314584
20 X 10.00 - 8	58276	319686		313654
20 X 10.00 - 10	55893	319687		
23 X 9.50 - 12	53655	319690	319689	314370

ACCESSORIES

Contact the dealer where your tractor was purchased for the available accessories. If you are unable to contact the dealer, write to the address on the front cover of this manual.

Rear Engine Rider

Model	Description
5708-16	Bagger - Fits 32" Side Discharge
5708-17	Bagger - Fits 36" Side Discharge & 30" Top Discharge
5709-02	Front Weight Box - holds 35 lbs.
5648-16	Lawn Sweeper w/dump Release
5714-00	Mulching Kit - 30" Top Discharge

Lawn Tractor

Model	Description
5708-22	Bagger - Fits 30" Side Discharge
5708-13	Bagger - Fits 36", 38", 39' & 45" Side Discharge
5705-04	36" Two-Stage Snowblower - Fits 36", 38", 39", & 45" Side Discharge
5661-06	42" Snowblade - Fits 36", 38", 39", & 45"
5592-00	Tire Chains - 18" x 6.50"
5585-00	Tire Chains - 18" x 9.50" & 20" x 8"
5672-01	Wheel Weights - Front - 1 pr. w/mtg. hdw. - Fits 15" tires
5673-02	Wheel Weights - Rear - 1 pr. w/mtg. hdw. - Fits 18" & 20" tires
5709-03	Front Weights - Fits 30" & 32" Side Discharge
5648-16	Lawn Sweeper w/dump Release
5714-00	Mulching Kit - 30" Top Discharge

Garden Tractor - Light Ground Engaging

Model	Description
5708-13	Bagger - Fits 36", 38", 39", & 45" Side Discharge
5705-04	36" Two-Stage Snowblower - Fits 36", 38", 39", & 45"
5661-06	42" Snowblade - Fits 36", 38", 39", & 45"
5672-01	Wheel Weights - Front 1 pr. w/mtg. hdw. - Fits 15" tires
5673-02	Wheel Weights - Rear - 1 pr. w/mtg. hdw. - Fits 18" & 20" tires
5648-16	Lawn Sweeper w/dump Release
5667-02	Sleeve Hitch - w/lift bar - Fits 45"
5668-01	Adaptor (sleeve hitch) for use w/23" tires
706-00	Tire Chains - 20" x 10"
671-00	Tire Chains - 23" x 9.50"
672-02	Wheel Weights - Front - 1 pr. w/mtg. hdw. Fits 16" tires
673-00	Wheel Weights - Rear - 1 pr. w/mtg. hdw. Fits 23" tires
674-01*	10" One Bottom Moldboard Plow
675-01*	Cultivator - 7 row - Adj. 6" - 42" width
676-01*	Disc Harrow - 8" & 11" disc - Adj. width & disc angle
677-02*	Tiller - 5 H.P. Self-Powered - 28" width

Four Wheel Steer

Model	Description
708-14	Bagger - Fits 40" & 46" Side Discharge
705-05	42" One-Stage Snowblower - Fits 40" & 46"
661-07	48" Snowblade - Fits 40" & 46"
709-04	Rear Weight Box for 40" & 46"
648-16	Lawn Sweeper w/dump Release
706-00	Tire Chains 20" x 10"
671-00	Tire Chains 23" x 9.50"
672-02	Wheel Weights - Front - 1 pr. w/mtg. hdw. Fits 16" tires
673-00	Wheel Weights - Rear - 1 pr. w/mtg. hdw. Fits 23" tires
672-01	Wheel Weights - Front - 1 pr. w/mtg. hdw. Fits 15" tires
673-02	Wheel Weights - Rear - 1 pr. w/mtg. hdw. Fits 18" & 20" tires

Two Wheel Steer Garden Tractor

Model	Description
567-04	Sleeve Hitch - w/lift bar Fits 46"
374-01*	10" One Bottom Moldboard Plow
375-01*	Cultivator - 7 row - Adj. 6" - 42" width
376-01*	Disc Harrow 8" & 11" Disc. Adj. width & disc angle
377-02*	Tiller 5 H.P. Self-Powered - 28" width
348-16	Lawn Sweeper w/dump Release

*requires a sleeve hitch