

# REPAIR PARTS MANUAL

## 40" - 12 H.P. LAWN TRACTOR

### MODEL C3560-150

#### ONE YEAR LIMITED WARRANTY

For one (1) year from date of purchase by the first consumer for residential use (thirty (30) days commercial use), NOMA Outdoor Products Incorporated warrants that it will replace free of charge, including labor, any original part of any NOMA Outdoor Products Incorporated product found to be defective by any authorized Service Dealer or the factory, except the battery which is warranted for ninety (90) days from date of purchase.

This warranty does not cover engine, transmission, transaxle or differential (these items are covered by their manufacturer's own warranty). This warranty does not cover parts that have failed due to normal wear or parts that have failed subject to misuse or abuse. Transportation of the unit or part to and from an authorized Service Dealer or factory is the responsibility of the owner.

A step by step explanation as to what procedure should be followed for this warranty is:

1. If a part becomes defective, contact the store where the unit was purchased for the name and address of the authorized Service Dealer nearest to you.
2. If you cannot locate an authorized Service Dealer, write Service Department of NOMA Outdoor Products Incorporated for the name and address of the authorized Service Dealer in your area or call the Service Department at 1-901-422-1690.
3. Return the defective product, along with proof of purchase to such authorized Service Dealer for replacement of any defective part where covered by this warranty.

There is no other express warranty. Implied warranties, including those of merchantability and fitness for a particular purpose are limited to one (1) year from date of purchase. Liability for incidental or consequential damages are excluded.

Some states do not allow limitations on how long an implied warranty lasts, so the above limitation may not apply to you. Some states do not allow the exclusion of incidental or consequential damages, so the above exclusion may not apply to you. This warranty gives you specific legal rights, and you may have other rights which vary from state to state.

**NOMA Outdoor Products Incorporated**

**Caller 8000**

**Jackson, TN 38308-8000**

#### UNIT PARTS AND SERVICE

Fill in and mail the registration card packed with the unit. For service other than covered in this manual, contact an authorized service dealer. When ordering repair parts, always give the following information: 1. The Part Name; 2. The Part Number; 3. The Quantity desired; 4. The Full (eight digit) Model Number of the unit. The model number will be found on a plate attached to the unit.



**Look for this symbol. It means - ATTENTION! BECOME ALERT! A HAZARD TO OPERATOR, BYSTANDER, PROPERTY OR EQUIPMENT MAY EXIST.**

**NOMA Outdoor Products Incorporated**

**Caller 8000**

**Jackson, TN 38308-8000**

Part No. 324600 *LS*

0292



## SAFETY RULES

THESE INSTRUCTIONS ARE FOR YOUR PROTECTION. PLEASE READ THEM CAREFULLY.



### IMPORTANT

THIS CUTTING MACHINE IS CAPABLE OF AMPUTATING HANDS AND FEET AND THROWING OBJECTS. FAILURE TO OBSERVE THE FOLLOWING SAFETY INSTRUCTIONS COULD RESULT IN SERIOUS INJURY OR DEATH.

#### I. GENERAL OPERATION:

- Know controls and how to stop quickly.
- Read, understand, and follow all instructions in the manual and on the machine before starting.
- Only allow responsible adults, who are familiar with instructions, to operate the machine.
- Wear safety glasses or eye shields when assembling or operating the machine.
- Do not operate machine when barefooted. Always wear substantial footwear, preferably steel-toed shoes.
- Do not wear loose fitting clothing that could get caught in moving parts.
- Clear the area of objects such as rocks, toys, wire, etc., which could be picked up and thrown by the blade(s).
- Be sure the area is clear of other people before mowing. Stop machine if anyone enters the area.
- Never carry passengers.
- Do not mow in reverse unless absolutely necessary. Always look down and behind before and while backing.
- Be aware of the mower discharge direction and do not point it at anyone. Do not operate the mower without either the entire grass catcher or the guard in place.
- Slow down before turning.
- Never leave a running machine unattended. Always turn off blades, set parking brake, stop engine, and remove keys before dismounting.
- Turn off blade(s) when not mowing.
- Stop engine before removing grass catcher or unclogging chute.
- Mow only in daylight or good artificial light.
- Do not operate the machine while under the influence of alcohol or drugs.
- Watch for traffic when operating near or crossing roadways.
- Use care when mowing around a fixed object to prevent the blade(s) from striking it. Never deliberately run over any foreign object.
- Use extra care when loading or unloading the machine into a trailer or truck.
- Use care when pulling loads or using heavy equipment.
  - a. Use only approved drawbar hitch points.
  - b. Limit loads to those that you can safely control.
  - c. Do not turn sharply. Use care when backing.
  - d. Use counterweight(s), wheel weight or tire chains when suggested in attachment(s) instructions.

#### II. SLOPE OPERATION:

Slopes are a major factor related to loss-of-control and tip-over accidents, which can result in severe injury or death. *All slopes require extra caution.* If you cannot back up the slope or if you feel uneasy on it, do not mow it.

##### DO

- Mow up and down slopes, not across.
- Remove obstacles such as rocks, tree limbs, etc.
- Watch for holes, ruts, or bumps. Uneven terrain could overturn the machine. *Tall grass can hide obstacles.*
- Use slow speed. Choose a low gear so that you will not have to stop or shift while on the slope.
- Follow the manufacturer's recommendations for wheel weights or counterweights to improve stability.
- Use extra care with grass catchers or other attachments. These can change the stability of the machine.
- Keep all movement on the slopes *slow* and *gradual*. Do not make sudden changes in speed or direction.
- Avoid starting or stopping on a slope. If tires lose traction, turn off the blade(s) and proceed slowly *straight* down the slope.

##### DO NOT

- Do not turn on slopes unless necessary, and then slowly and gradually downhill, if possible.
- Do not mow near drop-offs, ditches or embankments. The

mower could suddenly turn over if a wheel is over the edge of a cliff or ditch, or if an edge caves in.

- Do not mow on wet grass. Reduced traction could cause sliding.
- Do not try to stabilize the machine by putting your foot on the ground.
- Do not use grass catcher on steep slopes.

#### III. CHILDREN:

Tragic accidents can occur if the operator is not alert to the presence of children. Children are often attracted to the machine and the mowing activity. *Never* assume that children will remain where you last saw them.

- Keep children out of the mowing area and under the watchful care of another responsible adult.
- Be alert and turn machine off if children enter the area.
- Before and when backing, look behind and *down* for small children.
- Never carry children. They may fall off and be seriously injured or interfere with safe machine operation.
- Never allow children to operate the machine.
- Use extra care when approaching blind corners, shrubs, trees, or other objects that may obscure vision.

#### IV. SERVICE:

- Use extra care in handling gasoline and other fuels. They are flammable and vapors are explosive.
  - a. Use only an approved container.
  - b. Never remove gas cap or add fuel with the engine running. Allow engine to cool before refueling. Do not smoke.
  - c. Never refuel the machine indoors.
  - d. Never store the machine or fuel container inside where there is an open flame, such as in a water heater.
- Check fuel supply before each use allowing space for expansion as the heat of the engine and/or sun can cause gasoline to expand and overflow the tank.
- Use extra care when handling battery acid. Acid contact with skin may cause severe burns. Eye contact may cause blindness.
- Use extra care when servicing the battery. Explosive gas is produced in the battery. Do not service the battery while smoking or near an open spark or flame. This may cause the battery to explode causing serious injury.
- Never run a machine inside a closed area. Exhaust fumes contain CARBON MONOXIDE, an ODORLESS and DEADLY GAS.
- Keep nuts and bolts, especially blade attachment bolts, tight and keep equipment in good condition.
- Never tamper with safety devices. Check their operation regularly.
- Do not change the engine governor settings or overspeed engine.
- Reduce fire hazards. Keep machine free of grass, leaves, or other debris build-up. Clean up oil or fuel spillage. Allow machine to cool before storing.
- Stop and inspect the equipment if you strike an object. Repair, if necessary, before restarting.
- Never make adjustments or repairs with the engine running.
- Grass catcher components are subject to wear, damage, and deterioration, which could expose moving parts or allow objects to be thrown. Frequently check components and replace with manufacturer's recommended parts, when necessary.
- Mower blade(s) are sharp and can cut. Wrap the blade(s) or wear gloves, and use extra caution when servicing them.
- Check brake operation frequently. Adjust and service as required.



LOOK FOR THIS SYMBOL TO POINT OUT IMPORTANT SAFETY PRECAUTIONS. IT MEANS--ATTENTION!!! BECOME ALERT!!! YOUR SAFETY IS INVOLVED.

## OWNER'S INFORMATION

Record the following information about your unit so that you will be able to provide it in case of loss or theft.

MODEL NUMBER:  -  (Enter complete 8 digit number from model plate on unit)  
PURCHASE DATE: \_\_\_ / \_\_\_ / \_\_\_ CODE NO.: \_\_\_\_\_ SERIAL NO.: \_\_\_\_\_  
DEALER'S NAME AND ADDRESS: \_\_\_\_\_  
CITY: \_\_\_\_\_ STATE: \_\_\_\_\_ TELEPHONE: \_\_\_\_\_

### CONTENTS OF SHIPPING CARTON

- 1 - Lawn Tractor with 40 inch Mower Deck
- 1 - Operator's Manual
- 1 - Repair Parts Manual
- 1 - Engine Manual
- 1 - Steering Wheel (see Note)
- 1 - Seat (see Note)
- 2 - Tire & Rim Assemblies
- 1 - Bag of Assembly Parts Containing (see Note):
  - 1 - Oil Drain Trough
  - 4 - 5/16 x 3/4 inch Hex Head Screws
  - 4 - 5/16 inch Split Lockwashers
  - 4 - 11/32 inch Flatwashers
  - 1 - Spring Pin
  - 4 - Flatwashers
  - 2 - Retaining Rings
  - 2 - Hub Caps
  - 1 - Chute Deflector
  - 2 - Deck Wheels
  - 1 - Torsion Spring
  - 1 - Push Nut
  - 1 - Pivot Rod
  - 2 - Shoulder Bolts, 3/8-16
  - 2 - Nuts, Centerlock, 3/8-16

**NOTE:** Refer to page 22 (Customer Assembly Parts) for more detailed description.

### TOOLS REQUIRED FOR ASSEMBLY

- 2 - 7/16 inch Wrenches (or adjustable wrench)
- 1 - 1/2 inch Wrench (or adjustable wrench)
- 1 - Small Phillips Screwdriver with a 1/4 inch shank
- 1 - Hammer

### HOW TO MEASURE SCREW SIZE (5/16 x 1 1/2 INCH)

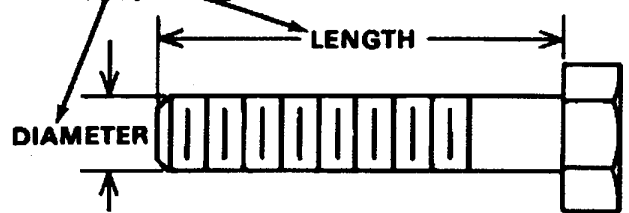

## DANGER



This lawn tractor can be dangerous if carelessly used.

Read your Operator's Manual thoroughly before operating your lawn tractor.

Always wear safety glasses or eye shields while assembling or operating your lawn tractor.

**DO NOT** carry passengers at any time.

Keep your hands, feet, hair and loose clothing away from the discharge area, the underside of the mower deck or any moving parts while the engine is running.

**DO NOT** allow children or young teenagers to operate or be near your lawn tractor while it is operating.

ALWAYS GIVE THE FOLLOWING INFORMATION WHEN ORDERING REPAIR PARTS:

1. The PART NUMBER; 2. The PART NAME; 3. QUANTITY DESIRED; 4. The MODEL NUMBER (As shown on Model Plate).

SEND PART ORDERS AS PER INSTRUCTIONS ON THE FRONT PAGE.

**DO NOT USE KEY NUMBERS WHEN ORDERING REPAIR PARTS, ALWAYS USE PART NUMBERS.**

All replacement parts will be supplied in current production colors or in a neutral color.

A handling fee is applicable to small parts orders.

YOUR UNIT IS RIGHT HAND (RH) OR LEFT HAND (LH) AS YOU STAND BEHIND IT.

# 40" LAWN TRACTOR MODEL C3560-150

## CHASSIS & HOOD ASSEMBLY

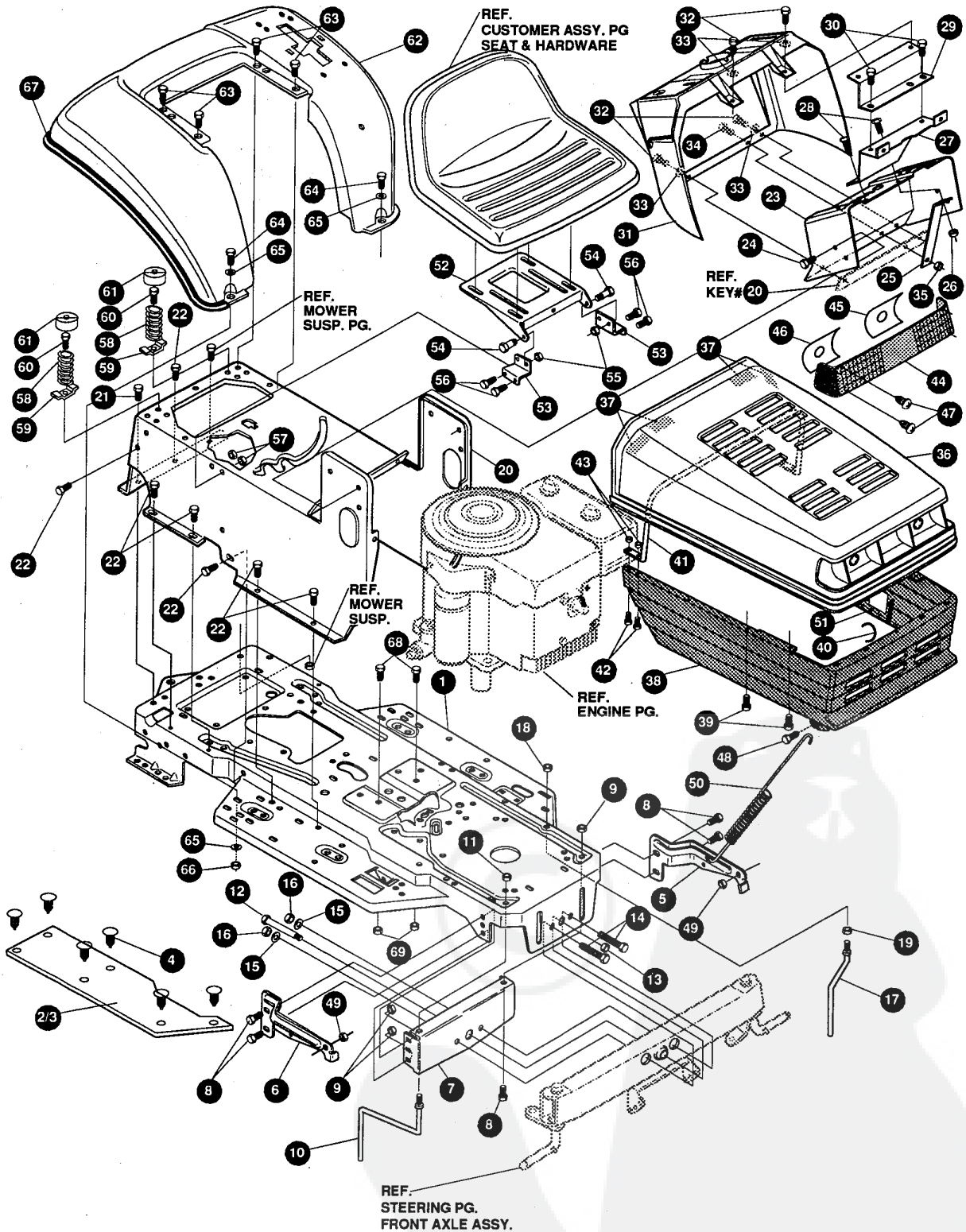

**NOTE: ALWAYS USE ORIGINAL EQUIPMENT PARTS.** Use of service/replacement parts other than original equipment parts may void your warranty.

**ALL UNNUMBERED ITEMS ARE INTERCHANGEABLE WITH OPPOSITE SIDE**

322340A

## 40" LAWN TRACTOR MODEL C3560-150

key#	part#	description	qty.
1	321708-889	FRAME	1
2	310005	FOOTPAD,LH	1
3	310006	FOOTPAD,RH	1
4	309235	FASTENER, RATCHET	12
5	302915-853	BRACKET,GRILLE LH	1
6	302914-853	BRACKET,GRILLE RH	1
7	313541-853	BRACKET, FRONT AXLE	1
8	• 56030	SCREW, 5/16-18X.75WDFLLK	5
9	• 55273	NUT, 5/16-18 HXWDFLLK	5
10	300440	GUIDE, BELT, RIDER	1
11	• 1498	NUT, 5/16-18 REGHEXCTRLK	1
12	308207	BOLT, .625X2.180 HSH 1/2-13	1
13	• 309008	NUT, 1/2-13 REGHCTRLK	1
14	• 122207	SCREW, 3/8-16X3.00 HHC	2
15	2483	WASHER, .391DX1.25DX.07 BELLVIL	2
16	• 1499	NUT, 3/8-16 REGHXCTRLK	2
17	300635	GUIDE,SHORT BELT RIDER 15"WH	1
18	• 124824	NUT, 5/16-18 HEXJAM	1
19	• 271190	NUT, 3/8-16 HEXKEPS	1
20	309661-889	CONSOLE W TOP SHIFT	1
21	• 35497	SCREW, 5/16-18X .50 WAHTAP	1
22	• 995346	SCREW, 1/4-20X .50 WAHTAP	13
23	58312-853	SUPPORT, DASH	1
24	• 300303	SCREW, .25X.75X.75HHWAPLASTITE	2
25	300201-853	BRACE, DASH SUPT LOWER	1
26	• 1502	NUT, 1/4-20 REGHEXCTRLK	1
27	302530-853	BRKT, GAS TANK	1
28	• 995346	SCREW, 1/4-20X .50 WAHTAP	2
29	300264-853	BRACE, DASH SUPT UPPER	1
30	• 995346	SCREW, 1/4-20X .50 WAHTAP	2
31	305428	DASH, W/O GRAPHIC,SUS	1
32	• 995346	SCREW, 1/4-20X .50 WAHTAP	4
33	316868	WASHER,SHOULDER NYLON .255X.46	4
34	• 44811	SCREW, 1/4-20X .75 HXWATAP	1
35	• 1502	NUT, 1/4-20 REGHEXCTRLK	1
36	307058-689	HOOD	1
37	318197	PAD,ADHESIVE 1.00 X	4
38	303037	GRILL,LWR	1
39	• 300302	SCREW, #10 X .50 HHTAPPST	4
40	310203	CLIP,HOG RING C-SHAPED	1
41	301425	BRACE,HOOD SUPPORT	1
42	• 301542	SCREW, 10-2451.00HWATAPBLKPHOS	4
43	• 271166	NUT, #10-24 HEXKEPS	4
44	302333	LENS, SMOKED W/TAB	1
45	301541	FOIL, REFLECTOR LENS H-11 LH	1
46	301540	FOIL, REFLECTOR LENS H-11 RH	1
47	• 57796	SCREW, #6 X .50 PLASTITE	4
48	56676	BOLT, .375X .580 HSH 5/16-18	2
49	• 1498	NUT, 5/16-18 REGHEXCTRLK	2
50	57478	SPRING, HOOD LATCH	2
51	301452	FOIL, HEAT REFLECTOR	1
52	58367-889	PLATE, SEAT F-5 SF & LF	1
53	310660-889	BRACKET, F-5 SEAT SUPPORT	1
54	20507	BOLT, .437X .156 HSH 5/16-18	2
55	• 1498	NUT, 5/16-18 REGHEXCTRLK	2
56	• 48901	SCREW, 5/16-18X .63 HHC	4
57	• 1498	NUT, 5/16-18 REGHEXCTRLK	4
58	57153	SPRING,SEAT 2.63LG,1.49OD	2
59	300284-953	CLAMP,SPRING 1.17"ID ZPL	2
60	• 44811	SCREW, 1/4-20X .75 HXWATAP	2
61	56907	COVER,SEAT SPRING 1.51DX1.0	2
62	58334-889	FENDER F-5 SUS LF FDR SHIFT	1
63	• 995346	SCREW, 1/4-20X .50 WAHTAP	4
64	• 122017	SCREW, 5/16-18X1.00 HHC	2
65	• 446363	WASHER, FLAT .375X .88X.082	4
66	• 1498	NUT, 5/16-18 REGHEXCTRLK	2
67	55021	TRIM,STRIP,BLACK	77.5"
68	180079	SCREW,5/16-18X1.00 HHC	2
69	1498	NUT, 5/16-18 REGHEXCTRLK	2
70	324599	OPERATOR'S MANUAL (NOT ILLUSTRATED)	1
71	324600	PARTS MANUAL (NOT ILLUSTRATED)	1

• Indicates STANDARD HARDWARE ITEMS.

# 40" LAWN TRACTOR MODEL C3560-150

## MOWER SUSPENSION ASSEMBLY

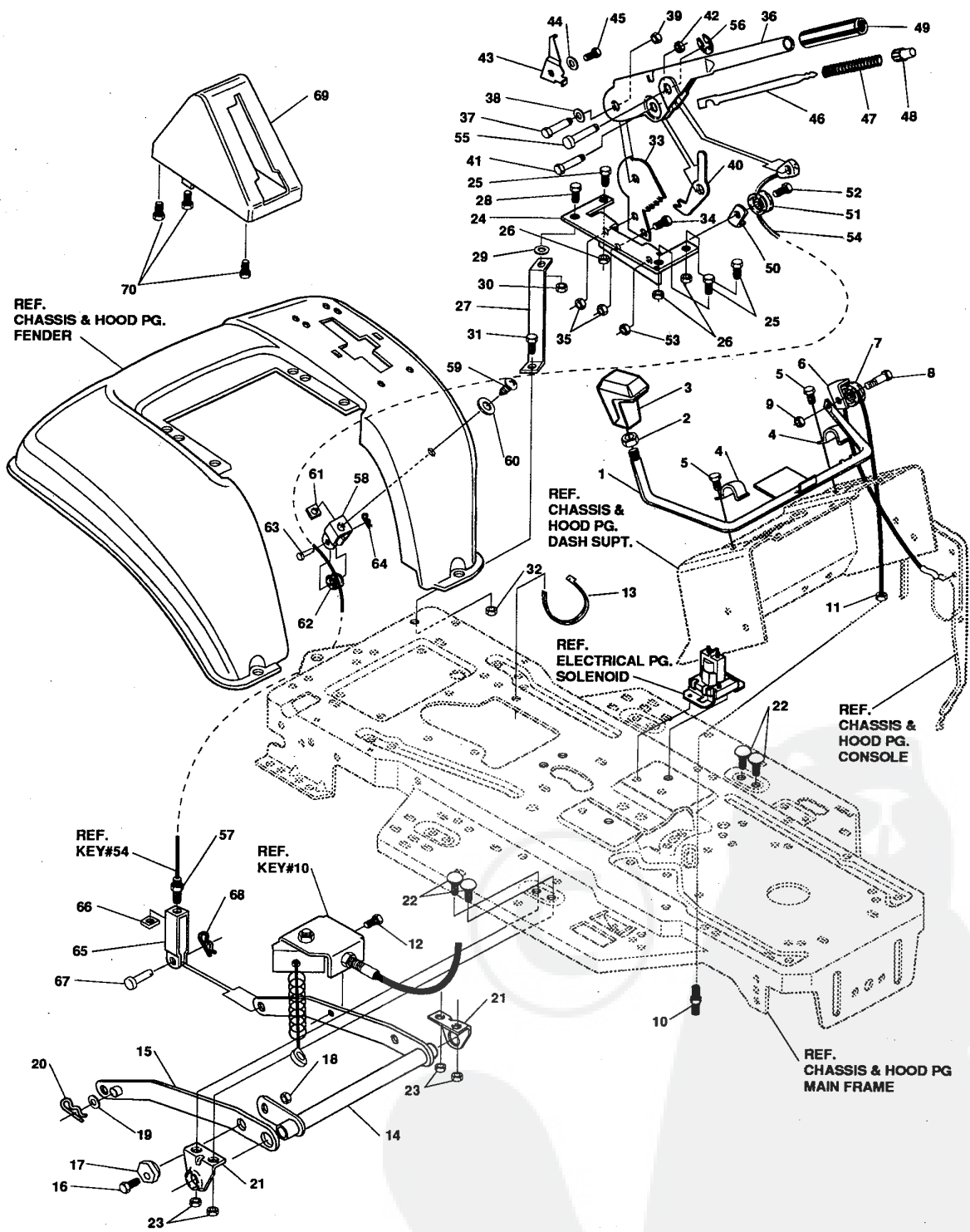

**NOTE: ALWAYS USE ORIGINAL EQUIPMENT PARTS.** Use of service/replacement parts other than original equipment parts may void your warranty.

**ALL UNNUMBERED ITEMS ARE INTERCHANGEABLE WITH OPPOSITE SIDE**

315597E

## 40" LAWN TRACTOR MODEL C3560-150

key#	part#	description	qty.
1	303044-853	ASSY,WELD,CLUTCH HANDLE	1
2	◊120238	NUT, 1/2-13 HEXJAM	1
3	304438-653	KNOB,SHIFT NOMA 1/2-13	1
4	58307-953	CLIP, RETAINING BRKT	2
5	◊995338	SCREW, 1/4-20X .63 HHWATAP	2
6	52456-953	BRACKET,CABLE RETAINER	1
7	39298	PULLEY, .906X.305 NYLON	1
8	57322	BOLT, .375X .375 HSH 1/4-20	1
9	◊1502	NUT, 1/4-20 REGHEXCTRLK	1
10	301491	ASSY,CL. CABLE GEN PWR	1
11	◊120613	NUT, 1/4-28 HJAM	1
12	◊35498	SCREW, 5/16-18X .75 WAHTAP	1
13	57444	TIE, CABLE BLACK NYLON 5.62L	1
14	300158-853	ASSY,REAR LIFT	1
15	300169-853	ASSY.LINK,RIGHT SIDE	1
16	◊180079	SCREW, 5/16-18X1.00 HHC	1
17	◊58247	ADJUSTING NUT	1
18	◊1498	NUT, 5/16-18 REGHEXCTRLK	1
19	◊417098	WASHER, FLAT .531X1.06X.095	2
20	8260	PIN, HAIR .091 DIA X1.66LG	2
21	58248-853	BRACKET,REAR HANGER SUSP.	2
22	126211	BOLT, 5/16-18X .63 CARR	4
23	◊1498	NUT, 5/16-18 REGHEXCTRLK	4
24	58333	BRACKET,HEIGHT ADJUST	1
25	◊180077	SCREW, 5/16-18X .75 HHC	3
26	◊1498	NUT, 5/16-18 REGHEXCTRLK	3
27	300336-889	BRACE, FENDER F-5 SUS	1
28	◊180079	SCREW, 5/16-18X1.00 HHC	1
29	◊45602	WASHER, FLAT .333X .87X.119	1
30	◊1498	NUT, 5/16-18 REGHEXCTRLK	1
31	◊180079	SCREW, 5/16-18X1.00 HHC	1
32	◊1498	NUT, 5/16-18 REGHEXCTRLK	1
33	301238	QUADRANT,HEIGHT ADJUST	1
34	◊180077	SCREW, 5/16-18X .75 HHC	2
35	◊1498	NUT, 5/16-18 REGHEXCTRLK	2
36	322292-853	HANDLE,LIFT HEIGHT ADJUST	1
37	300171	BOLT, .500X .270 HSH 5/16-18	1
38	996418	WASHER, FLAT .506X .75X.024	1
39	◊44108	NUT, 5/16-18 HWDFLCTRLK	1
40	301239	PAWL, HEIGHT ADJUST	1
41	300171	BOLT, .500X .270 HSH 5/16-18	1
42	◊44108	NUT, 5/16-18 HWDFLCTRLK	1
43	300782-953	POINTER,HEIGHT ADJUST	1
44	138479	WASHER, EXLK .195X.41X.03	1
45	◊35287	SCREW, #8-32X .38 HHWATAPGR2	1
46	303027	ROD,ACTUATOR-SHORT	1
47	58326	SPRING, HEIGHT ADJUST	1
48	58325	KNOB,HEIGHT ADJUST PUSH BUTTON	1
49	58329	GRIP .750 OD W/ HOLE BLK	1
50	58335-953	BRACKET,CABLE RETAINER	1
51	39298	PULLEY, .906X.305 NYLON	1
52	58336	BOLT, .375X .375 HSH 1/4-20	1
53	◊1502	NUT, 1/4-20 REGHEXCTRLK	1
54	314177	CABLE, LIFT 23.30 F-5 20X8-8	1
55	300310	PIN,CLEVIS .310DIA+.475LG	1
56	300311	RING, RET E .31X.24	1
57	◊120375	NUT, 1/4-20 REGHEX	1
58	300298-953	CLEVIS	1
59	◊439455	SCREW, 5/16-18X .56PHPNMA BKPH	1
60	301551	WASHER, .344ID X1.50DX.09 CU BPH	1
61	◊120373	NUT, 5/16-18 SQ	1
62	39298	PULLEY, .906X.305 NYLON	1
63	300317	PIN, CLEVIS .38 DIA X1.00 LG	1
64	8260	PIN, HAIR .091 DIA X1.66LG	1
65	300703-953	CLEVIS, LIFT CABLE	1
66	◊120372	NUT, 1/4-20 REGSQ	1
67	39522	PIN, CLEVIS .312 X .812	1
68	121222	PIN, COTTER .090/.086X.75LG	1
69	300335	LIFT COVER-39" F5	1
70	◊300340	SCREW, #10 X .75 HHPLAST	3

◊STANDARD HARDWARE ITEMS

# 40" LAWN TRACTOR MODEL C3560-150

## STEERING ASSEMBLY

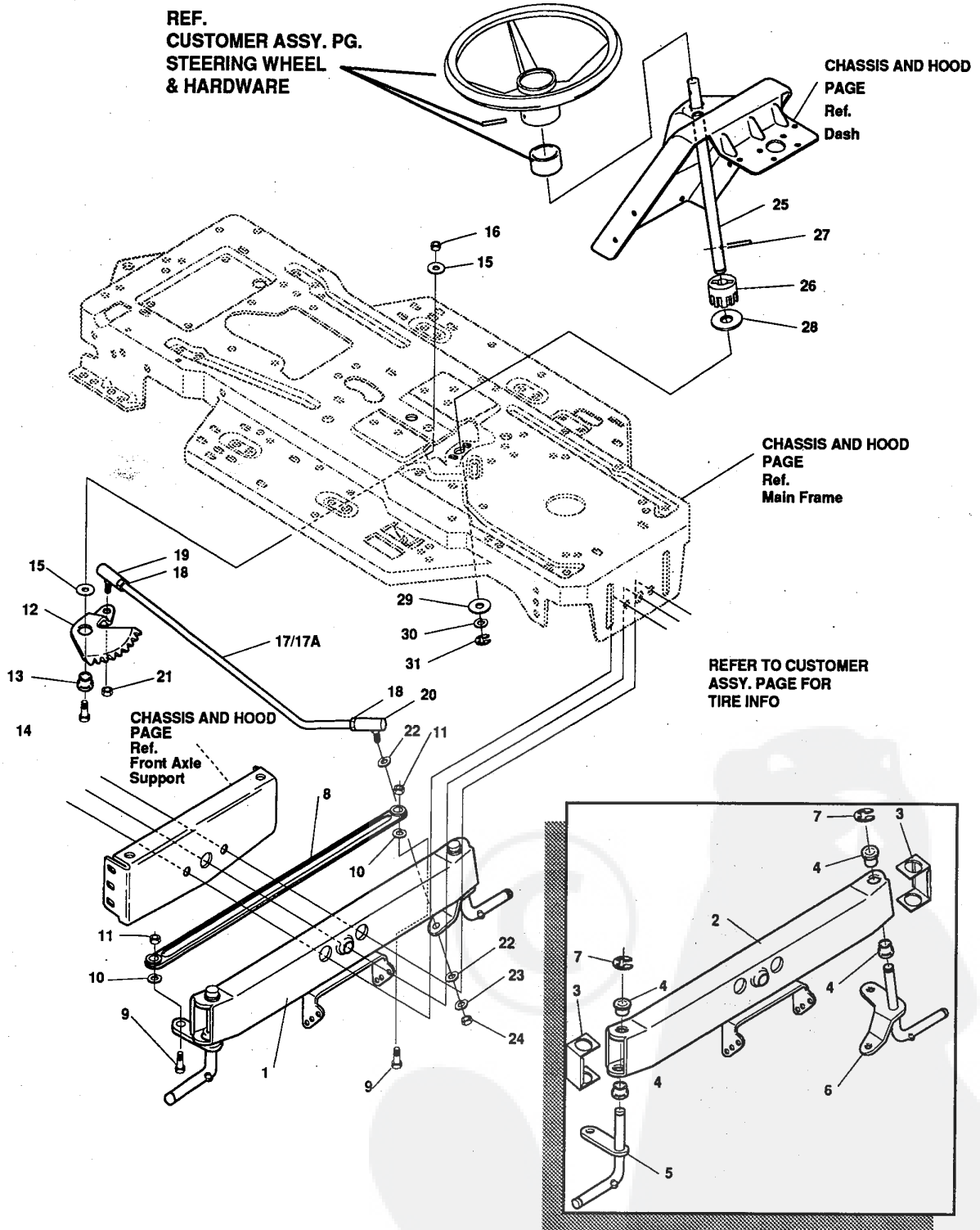

**NOTE: ALWAYS USE ORIGINAL EQUIPMENT PARTS.** Use of service/replacement parts other than original equipment parts may void your warranty.

**ALL UNNUMBERED ITEMS ARE INTERCHANGEABLE WITH OPPOSITE SIDE**

315650E



## 40" LAWN TRACTOR MODEL C3560-150

key#	part#	description	qty.
1.	*	ASSY,AXLE FRONT 4/WS SUSP	1
2.	300272	ASSY FRONT AXLE SUSPENDE	1
3.	53373	AXLE COVER	2
4.	52407	SPINDLE BEARING	4
5.	302926	ASSY,SPINDLE RH	1
6.	315886	ASSY,SPINDLE LH	1
7.	36625	RING, RETEX .57X.05TRU5133-75	2
8.	304590	TIE ROD ASSY 19.81LG W-SECTION	1
9.	• 180128	SCREW, 3/8-16X1.75 HHC	2
10.	120382	WASHER, REGSPTLK.393X.68X.10	2
11.	• 1499	NUT, 3/8-16 REGHXCTRLK	2
12.	58289	SECTOR, STEERING LF	1
13.	52406	BRNG,FL ECC.510IDX .998ODX .56	1
14.	• 180177	SCREW, 1/2-13X1.50 HHC	1
15.	22265	WASHER, FLAT .515X1.38X.119PL	2
16.	• 1500	NUT, 1/2-13 REGHCTRLK	1
17.	300146	DRAGLINK ASSY	1
17A.	58291	STEERING LINK	1
18.	• 124925	NUT, 3/8-24 REGHEXJAM	2
19.	57158	BALL JOINT 3/8 THD SHORT STUD	1
20.	21275	BALL JOINT 3/8 TH'D LONG STUD	1
21.	• 46692	NUT, 3/8-24 WDFLHLK WHIZ	1
22.	996416	WASHER, FLAT .391X1.00X.125	2
23.	120382	WASHER, REGSPTLK.393X.68X.10	1
24.	• 120369	NUT, 3/8-24 REGHEX	1
25.	58243	SHAFT, STEERING LF	1
26.	58244	PINION, STEERING LF	1
27.	58274	PIN,DOWEL .2500 OD+1.75LG PL	1
28.	301410	BRNG, FL .752IDX1.061ODX .24	1
29.	301398	WASHER, FORMED1.135X1.53X.12	1
30.	21682	WASHER, FLAT .765X1.25X.042	1
31.	36625	RING, RETEX .57X.05TRU5133-75	1

\* Order Individual Parts.

• STANDARD HARDWARE ITEMS

# 40" LAWN TRACTOR MODEL C3560-150

## MOTION DRIVE ASSEMBLY

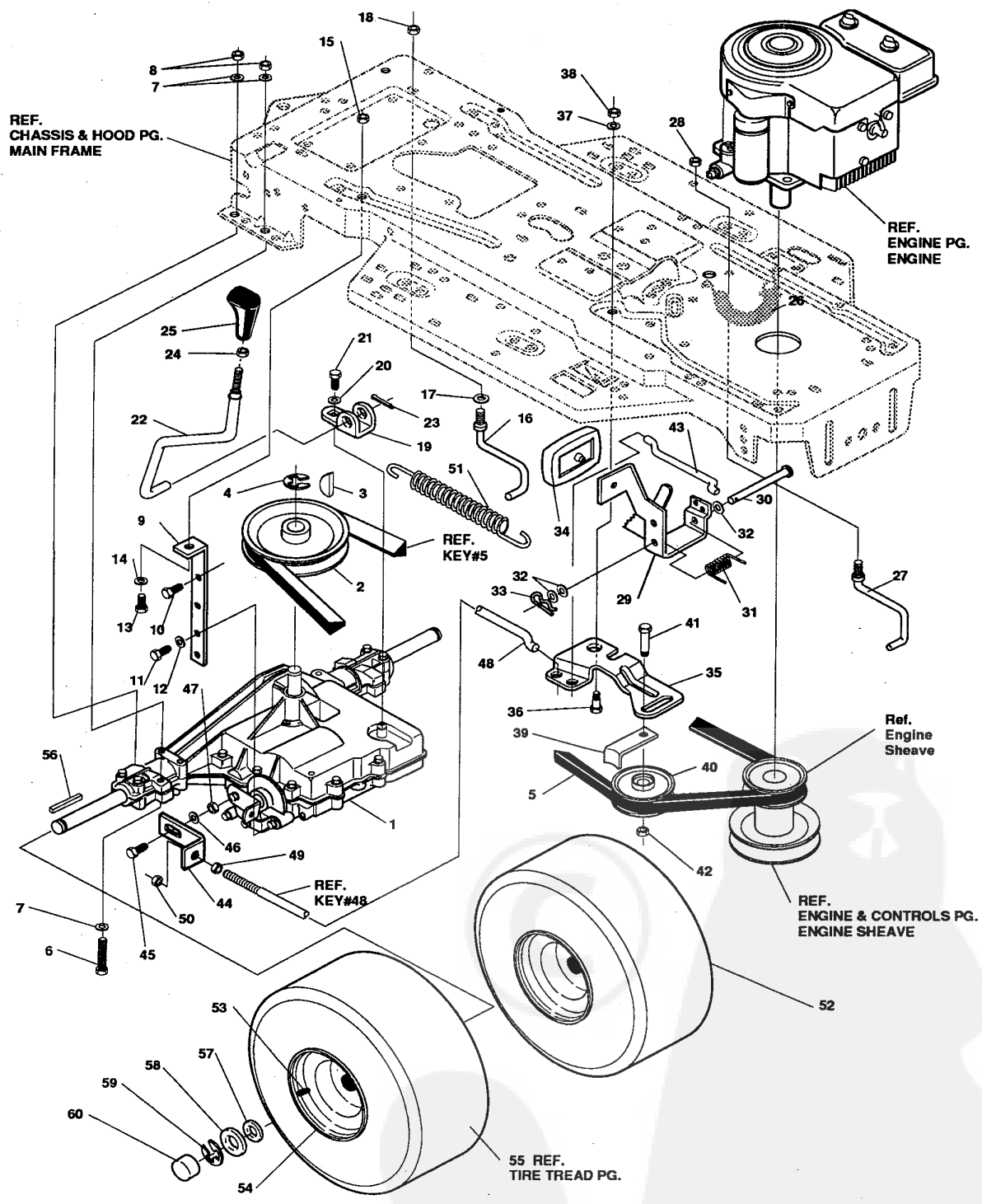

**NOTE: ALWAYS USE ORIGINAL EQUIPMENT PARTS.** Use of service/replacement parts other than original equipment parts may void your warranty.

**ALL UNNUMBERED ITEMS ARE INTERCHANGEABLE WITH OPPOSITE SIDE**

317830E

## 40" LAWN TRACTOR MODEL C3560-150

key#	part#	description	qty.
1	*	TRANSAXLE PEERLESS	1
2	302745	PULLEY,V 4L 6.60 OD	1
3	3021	KEY, WDRF 606 .750X.187X.312	1
4	22053	RING, RETEX .58X.04TRU5100-62	1
5	314120	BELT	1
6	◊180089	SCREW, 5/16-18X2.25 HHC	4
7	120393	WASHER, FLAT .344X .69X.065	8
8	◊1498	NUT, 5/16-18 REGHEXCTRLK	4
9	323471	STABILIZER BRKT	1
10	◊50947	SCREW, 3/8-16X1.25 WAHHTAP	1
11	◊35498	SCREW, 5/16-18X .75 WAHHTAP	1
12	120638	WASHER, HVSPTLK .328X.60X.09	1
13	◊122017	SCREW, 5/16-18X1.00 HHC	1
14	120393	WASHER, FLAT .344X .69X.065	1
15	◊1498	NUT, 5/16-18 REGHEXCTRLK	1
16	57259	GUIDE, BELT 5/16-18THD	1
17	138538	WASHER, REGINTLK.320X.61X.03	1
18	◊1498	NUT, 5/16-18 REGHEXCTRLK	1
19	310754-955	BRKT,SHIFT	1
20	57157	WASHER,.750X.250 SP-TRANSAXLE	1
21	◊56255	SCREW, 1/4-28X .75 NYLHHC	1
22	57169	LEVER, SHIFT	1
23	137185	PIN, COTTER .125 DIA X1.00	1
24	◊120238	NUT, 1/2-13 HEXJAM	1
25	304438	KNOB,SHIFT NOMA 1/2-13	1
26	321514	SPRING BIAS DRAGLINK	1
27	304016	GUIDE,BELT	1
28	1498	NUT, 5/16-18 REGHEXCTRLK	1
29	300308	PEDAL ASSY,BRAKE/CLUTCH	1
30	319675	PIN CLEVIS	1
31	57847	SPRING, BRAKE PEDAL	1
32	2968	WASHER, FLAT .504X .75X.059	3
33	56180	PIN,HAIR	1
34	48160	PAD, CLUTCH BRAKE	1
35	300154	ARM,IDLER TRACTION DR.	1
36	300793	BOLT, .625X .135 HSH 5/16-18	1
37	45602	WASHER, FLAT .333X .87X.119	1
38	◊1498	NUT, 5/16-18 REGHEXCTRLK	1
39	39659	RETAINER, STRAP BELT	1
40	35374	PULLEY, IDLER	1
41	45892	BOLT, 3/8-16X1.50 CARR	1
42	◊1499	NUT, 3/8-16 REGHXCTRLK	1
43	57204	ROD, CLUTCH	1
44	57217	BRACKET, BRAKE ROD	1
45	20507	BOLT, .437X .156 HSH 5/16-18	1
46	45602	WASHER, FLAT .333X .87X.119	1
47	◊1498	NUT, 5/16-18 REGHEXCTRLK	1
48	313659	ROD, BRAKE	1
49	◊271184	NUT, 5/16-18 HEXKEPS	1
50	◊1498	NUT, 5/16-18 REGHEXCTRLK	1
51	56359	SPRING, CLUTCH .113X.750X8.75	1
52	~	TIRE & RIM, PU 20X8.00	2
53	24167	VALVE STEM	1
54	57165	WHEEL 20X8.00 WHITE	1
55		REFER TO TIRE TREAD PAGE	1
56	52928	KEY, SQUARE .187SQX2.25	2
57	642	WASHER, FLAT .755X1.31X.075	4
58	42815	WASHER, FLAT .755X1.53X.07	2
59	36625	RING, RETEX .57X.05TRU5133-75	2
60	40394	CAP, 1.500ID X 7/8LG HUB	2

◊ Indicates STANDARD HARDWARE ITEMS.

\* CONTACT YOUR NEAREST TRANSAXLE DEALER FOR PARTS & SERVICE.

~ ORDER INDIVIDUAL PARTS.

# 40" LAWN TRACTOR MODEL C3560-150

## ENGINE & CONTROL ASSEMBLY

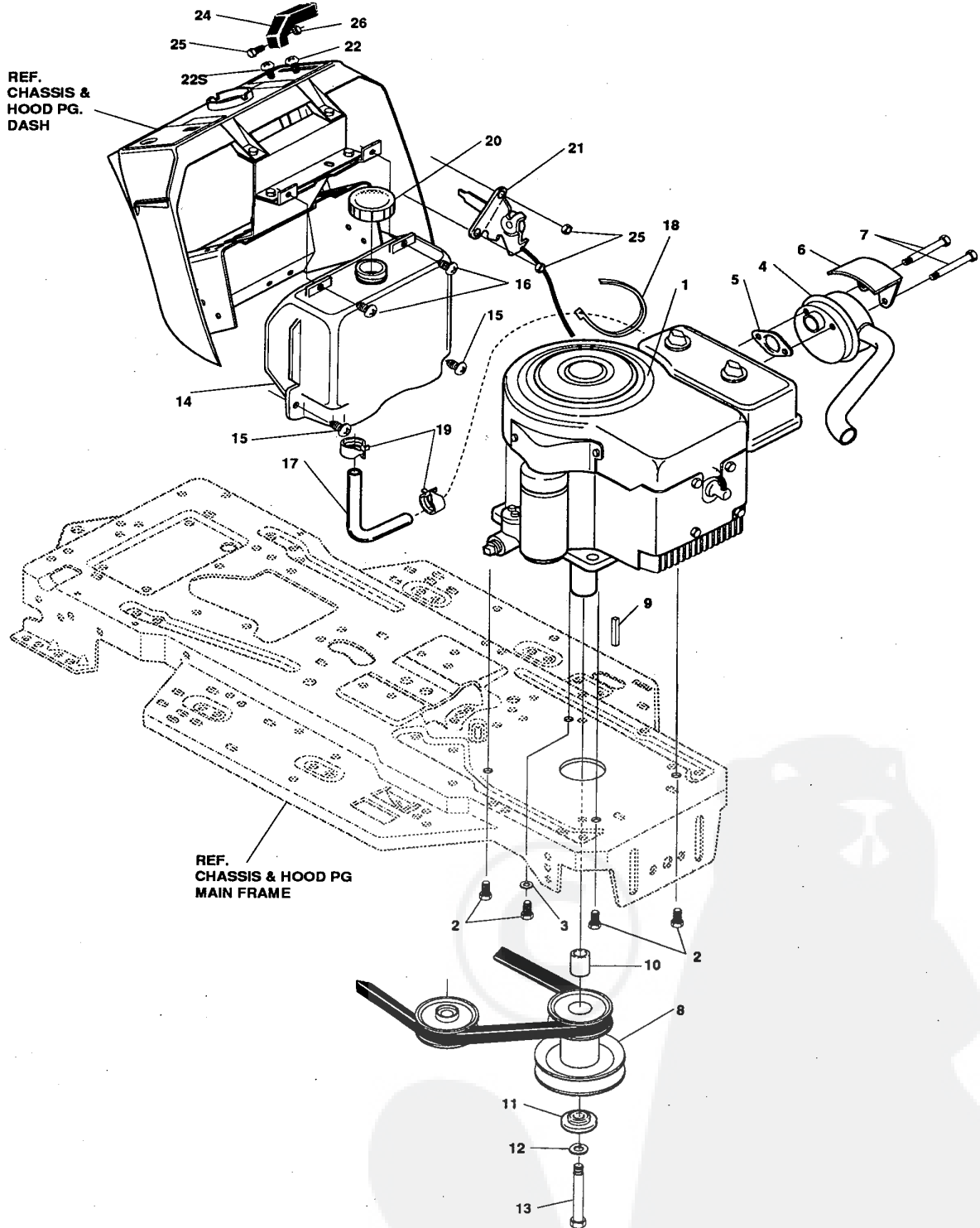

**NOTE: ALWAYS USE ORIGINAL EQUIPMENT PARTS.** Use of service/replacement parts other than original equipment parts may void your warranty.

**ALL UNNUMBERED ITEMS ARE INTERCHANGEABLE WITH OPPOSITE SIDE**

322768A

## 40" LAWN TRACTOR MODEL C3560-150

key#	part#	description	qty.
1	ENGINE	12 HP B&S I/C ECONO (SEE ENGINE MANUAL)	1
2	50947	SCREW, 3/8-16X1.25 WAHHTAP	4
3	138489	WASHER, EXLK .384X.69X.04	1
4	305367	MUFFLER-LO TONE NELSON EXPORT	1
5	46708	GASKET, MUFFLER	1
6	54767	SHIELD, HEAT, FOR ROUND MUFFLER	1
7	173063	SCREW, 5/16-18X3.50 HHC	2
8	310250	PULLEY ENG. V3L 4.00 OFFSET	1
9	303151	KEY, SQUARE .250SQX5.00LG	1
10	304246	SPACER, 1.01X1.484 ENGIN PULLEY	1
11	56431	WASHER, .980IDX1.38ODX.437PILOT	1
12	120383	WASHER, REGSPTLK.459X.78X.12	1
13	433146	SCREW, 7/16-20X4.25 HHC	1
14	314991	TANK, FUEL 2-GAL	1
15	300303	SCREW, .25X.75X.75HHWAPLASTITE	2
16	995346	SCREW, 1/4-20X .50 WAHHTAP	2
17	47452	GAS LINE .25ID	14"
18	57444	WIRE TIE	1
19	48672	CLAMP, FUEL LINE	2
20	300304	CAP, FUEL - 2.0 THROAT	1
21	303159	THROTTLE, CONTROL	1
22	320553	SCREW, 10-24X .63PHPNMA	2
23	271166	NUT, #10-24 HEXKEPS	2
24	300508	KNOB, THROTTLE CONTROL HANDGRIP	1
25	159585	SCREW, #8-32X .38 PHPNMA	1
26	120622	NUT, #8-32 REGHX	1

• STANDARD HARDWARE ITEMS.

# 40" LAWN TRACTOR MODEL C3560-150

## PRE-PAINTED DECK ASSEMBLY

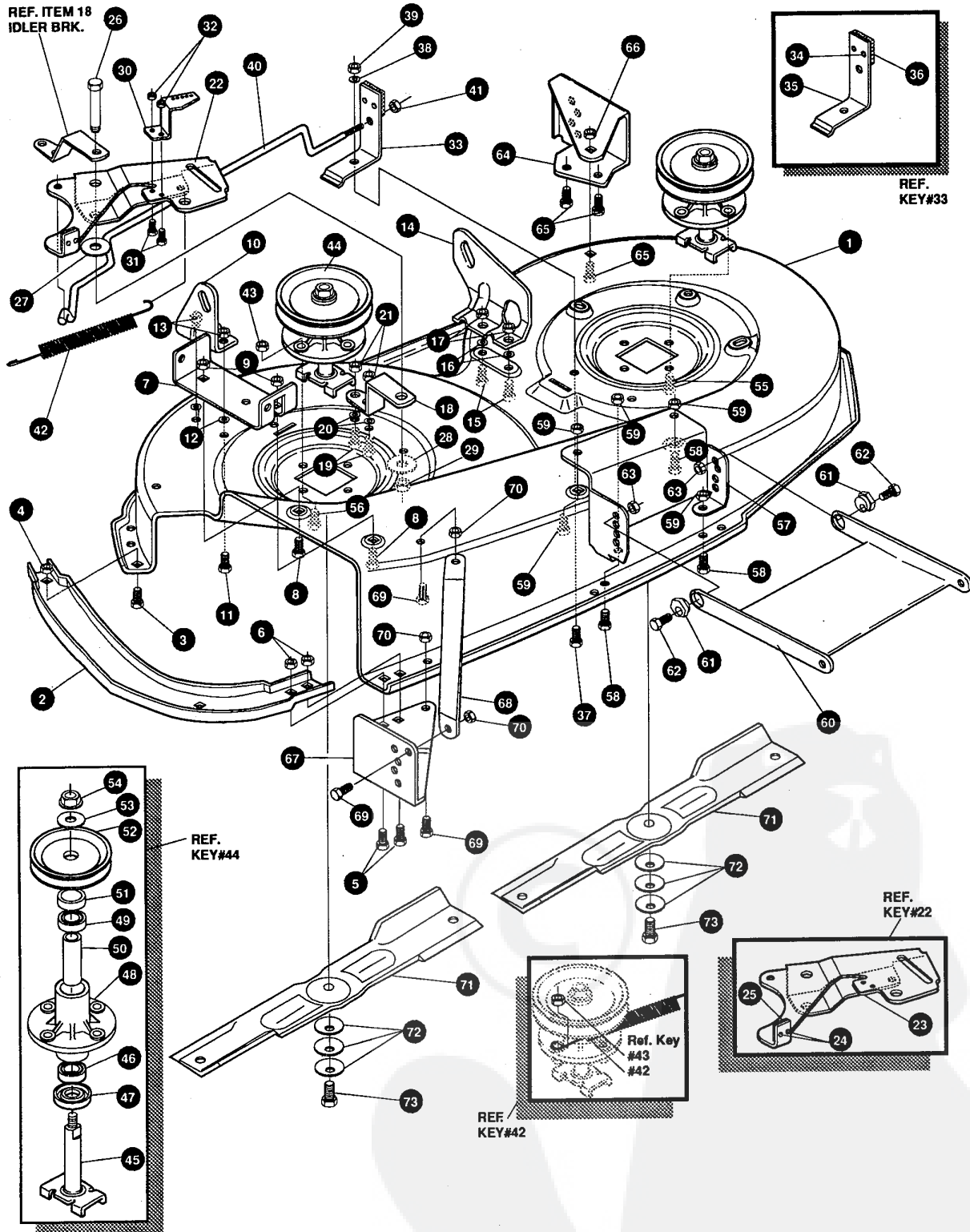

**NOTE: ALWAYS USE ORIGINAL EQUIPMENT PARTS.** Use of service/replacement parts other than original equipment parts may void your warranty.

**ALL UNNUMBERED ITEMS ARE INTERCHANGEABLE WITH OPPOSITE SIDE**

320109C

## 40" LAWN TRACTOR MODEL C3560-150

key#	part#	description	qty.
1.	322114-853	MOWER DECKS, RIDER 40"	1
2.	304102	TOE GUARD	1
3.	• 180075	SCREW, 5/16-18X .63 HHC	1
4.	• 1498	NUT, 5/16-18 REGHEXCTRLK	1
5.	• 122007	SCREW, 5/16-18X .75 HHC	2
6.	• 1498	NUT, 5/16-18 REGHEXCTRLK	2
7.	302364	BRACKET CHUTE MOUNT	1
8.	• 180075	SCREW, 5/16-18X .63 HHC	2
9.	• 1498	NUT, 5/16-18 REGHEXCTRLK	2
10.	58250	BRACKET,RH LIFT REAR	1
11.	180077	SCREW, 5/16-18X .75 HHC	2
12.	120393	WASHER, FLAT .344X .69X.065	2
13.	• 1498	NUT, 5/16-18 REGHEXCTRLK	2
14.	58251	BRACKET,LH LIFT REAR	1
15.	• 180077	SCREW, 5/16-18X .75 HHC	2
16.	120393	WASHER, FLAT .344X .69X.065	2
17.	• 1498	NUT, 5/16-18 REGHEXCTRLK	2
18.	302363	BRACE IDLER	1
19.	• 180077	SCREW, 5/16-18X .75 HHC	2
20.	120393	WASHER, FLAT .344X .69X.065	2
21.	44108	NUT, 5/16-18 HWDFLCTRLK	2
22.	320576	IDLER ARM ASSEMBLY	1
23.	322116	ARM IDLER 40"DECK EURO	1
24.	41601	RIVET, OVSET .187DIAX .50	2
25.	306973	BRAKE PAD - HARD	1
26.	304420	BOLT, .500X2.15 HXHDCPSH	1
27.	996307	WASHER, FLAT .391X1.00X.209	1
28.	996416	WASHER, FLAT .391X1.00X.125	2
29.	45171	NUT, 3/8-16 HWDFL WHIZ-LOCK	1
30.	300700	BRACKET, EXTENSION IDLER	1
31.	120228	SCREW, 5/16-18 X .63 HHC	2
32.	1498	NUT, 5/16-18 REGHEXCTRLK	2
33.	321828	BLADE BRAKE ASSY.	1
34.	135624	RIVET, TRSET .185DIAX .41LG	2
35.	304119	BRAKE ARM	1
36.	306973	BRAKE PAD	1
37.	• 120228	SCREW, 5/16-18X .63 HHC	1
38.	120393	WASHER, FLAT .344X .69X.065	1
39.	• 1498	NUT, 5/16-18 REGHEXCTRLK	1
40.	302714	ROD, BRAKE	1
41.	1502	NUT, 1/4-20 REGHEXCTRLK	1
42.	35410	SPRING .071 X .62 X 4.37	1
43.	• 1498	NUT, 5/16-18 REGHEXCTRLK	1
44.	56424	QUILL ASSY, 36/39/40/43	2
45.	56425	SHAFT/SADDLE 36"	1
46.	49562	BRNG, BALL .669IDX1.575ODX.472	1
47.	50616	DUST SHIELD	1
48.	55547	QUILL CASTING (1046)	1
49.	49562	BRNG, BALL .669IDX1.575ODX.472	1
50.	50818	SPACER, SLEV .669X .88X3.797	1
51.	51449	SPACER, SLEV .672X .93X .438PM	1
52.	56390	PULLEY,26/36" QUILL	1
53.	56365	WASHER, SPECIAL QUILL	1
54.	1282	NUT, 7/16-20 WDFLLK	1
55.	50634	SCREW, 5/16-18X .88 WAHHTAP	7
56.	300345	SCREW, 5/16-18X1.38 WATAP	1
57.	318445	BRACKET,40 LF FRONT DECK	1
58.	• 180075	SCREW, 5/16-18X .63 HHC	4
59.	• 1498	NUT, 5/16-18 REGHEXCTRLK	4
60.	58305	BRACKET,LINK DECK FRONT	1
61.	58247	ADJUSTING NUT	2
62.	• 122017	SCREW, 5/16-18X1.00 HHC	2
63.	• 1498	NUT, 5/16-18 REGHEXCTRLK	2
64.	304426	BRACKET,GAGE WHEEL L.H.	1
65.	• 180075	SCREW, 5/16-18X .63 HHC	3
66.	• 1498	NUT, 5/16-18 REGHEXCTRLK	3
67.	313925	BRACKET,GAGE WHEEL R.H. FRNT	1
68.	314282	BRACKET,STABILIZER	1
69.	• 180075	SCREW, 5/16-18X .63 HHC	3
70.	• 1498	NUT, 5/16-18 REGHEXCTRLK	3
71.	305012	BLADE, 40" STD-LIFT 20.324	2
72.	2483	WASHER,.39IDX1.25DX.07 BELLVIL	6
73.	39573	SCREW, 3/8-24X1.00 NYLHHC	2

• Indicates STANDARD HARDWARE ITEMS.





## 40" LAWN TRACTOR MODEL C3560-150

key#	part#	description	qty.
1.	*	DECK,40" MOWER 2-WH EXPORT	1
2.	58306	ROD, DECK-HITCH	1
3.	8260	PIN, HAIR .091 DIA X 1.66LG	1
4.	57325	BOLT, 3/8-16 X 2.00 CARR	1
5.	25210	WASHER, FLAT .392 X 1.25 X .09	1
6.	300844-953	RETAINER, BELT	1
7.	310326	PULLEY, IDLER BFF 4.00 WIDE FL	1
8.	996307	WASHER, FLAT .391 X 1.00 X .209	1
9.	120382	WASHER, REGSPTLK.393 X .68 X .10	1
10.	• 120377	NUT, 3/8-16 REGHX	1
11.	300473	SPRING, TENSION 7.52LG+17LB/IN	1
12.	319005	BELT, V 5L 81.00 DECK 40 LF	1
13.	302833	GUARD, BELT LH PLASTIC	1
14.	• 120228	SCREW, 5/16-18 X .63 HHC	3
15.	120393	WASHER, FLAT .344 X .69 X .065	3
16.	• 1498	NUT, 5/16-18 REGHEXCTRLK	3

\* ORDER INDIVIDUAL PARTS.

• Indicates STANDARD HARDWARE ITEMS

# 40" LAWN TRACTOR MODEL C3560-150

## ELECTRICAL ASSEMBLY

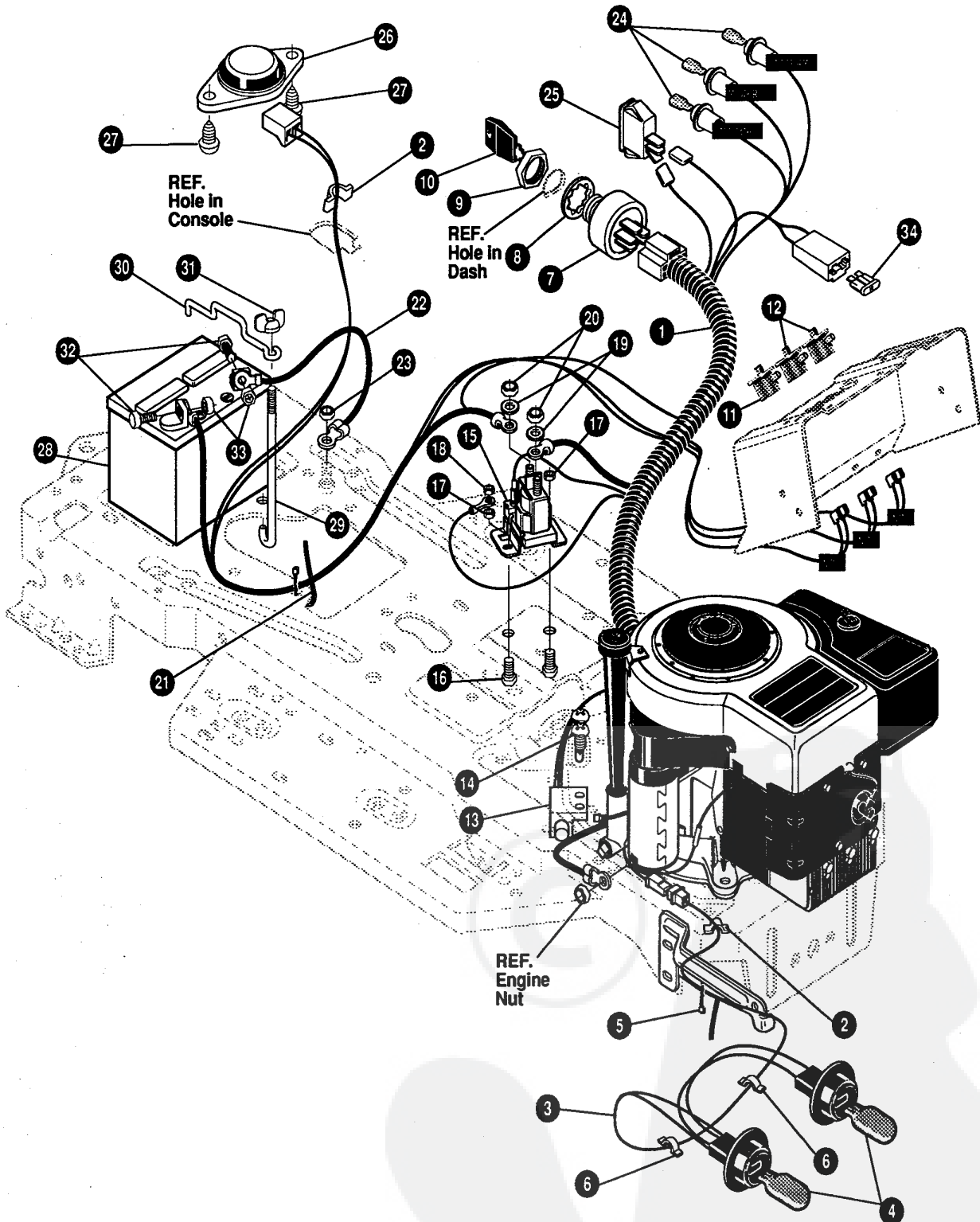

**NOTE: ALWAYS USE ORIGINAL EQUIPMENT PARTS.** Use of service/replacement parts other than original equipment parts may void your warranty.

**ALL UNNUMBERED ITEMS ARE INTERCHANGEABLE WITH OPPOSITE SIDE**

322767A

# 40" LAWN TRACTOR MODEL C3560-150

key#	part#	description	qty.
1.	320067	HARNESH 12-12.5,H11G14,WRAP,LF	1
2.	41482	PRESS CLIP,1.380LG .255ID	2
3.	303064	ASSY,LIGHT WIRE-1/4 TURN	1
4.	52572	BULB, HEADLAMP	2
5.	57444	TIE, CABLE BLACK NYLON 5.62L	1
6.	41482	PRESS CLIP,1.380LG .255ID	1
7.	305720	SWITCH-IGN.(AFTER FIRE) 3 POSN	2
8.	300193	NUT, 5/8-32 ACC #125 PLAST BLK	1
9.	300194	BOOT, IGN SWITCH	1
10.	300626	KEY, IGNITION SWITCH	1
11.	300220	SWITCH,SNAPMNT NO .055/.116BLK	1
12.	58277	SWITCH,SNAPMNT NC .055/.166 GR	1
13.	57476	SWITCH,SCR MNT DP NC NO BLK	2
14.	57220	SCREW, #12 X .50 PHPNHTAP BLK	1
15.	53716	SOLENOID	2
16.	187745	SCREW, 1/4-20X .75 HXSEMMA	2
17.	1502	NUT, 1/4-20 REGHEXCTRLK	2
18.	271172	NUT, 1/4-20 REGHEXKEPS	2
19.	138485	WASHER, EXLK .320X.61X.03	1
20.	120368	NUT, 5/16-24 REGHEX	2
21.	57444	TIE, CABLE BLACK NYLON 5.62L	1
22.	55511	WIRE, GROUND, 12.5"	1
23.	271184	NUT, 5/16-18 HEXKEPS	1
24.	57769	BULB, INDICATOR	1
25.	300334	LIGHT SWITCH ON/OFF PANEL MNT	3
26.	57547	SWITCH, SEAT	1
27.	160505	SCREW, 1/4-20X .38PHPNHMAGR2	1
28.	302257	BATTERY 12V 7 PLATE	2
29.	57551	ROD, BATTERY	1
30.	57552	ROD, BATTERY, TOP	1
31.	310067	NUT, WING 1/4-20 SMALL PLASTIC	1
32.	120854	SCREW, 1/4-20X .63 HHC GR2	1
33.	271172	NUT, 1/4-20 REGHEXKEPS	2
34.	302031	FUSE,15 AMP SPADE TYPE	1

- Indicates STANDARD HARDWARE ITEMS.
- SPADE TYPE FUSES ARE INCLUDED WITH THE WIRE HARNESH.

## SCHEMATIC DRAWING:

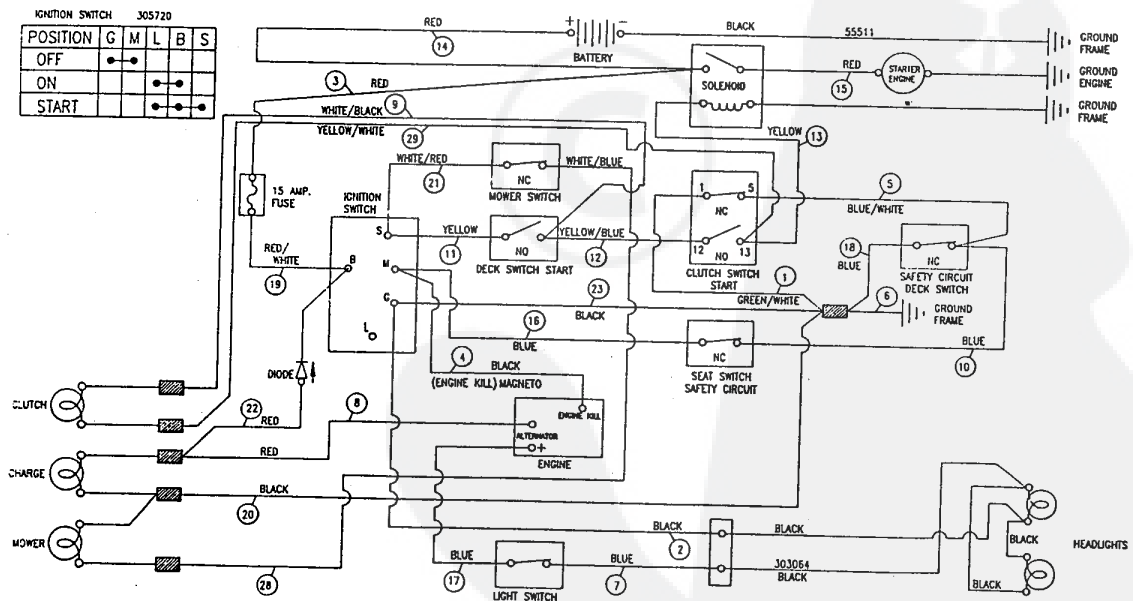

# 40" LAWN TRACTOR MODEL C3560-150

## DECAL ASSEMBLY

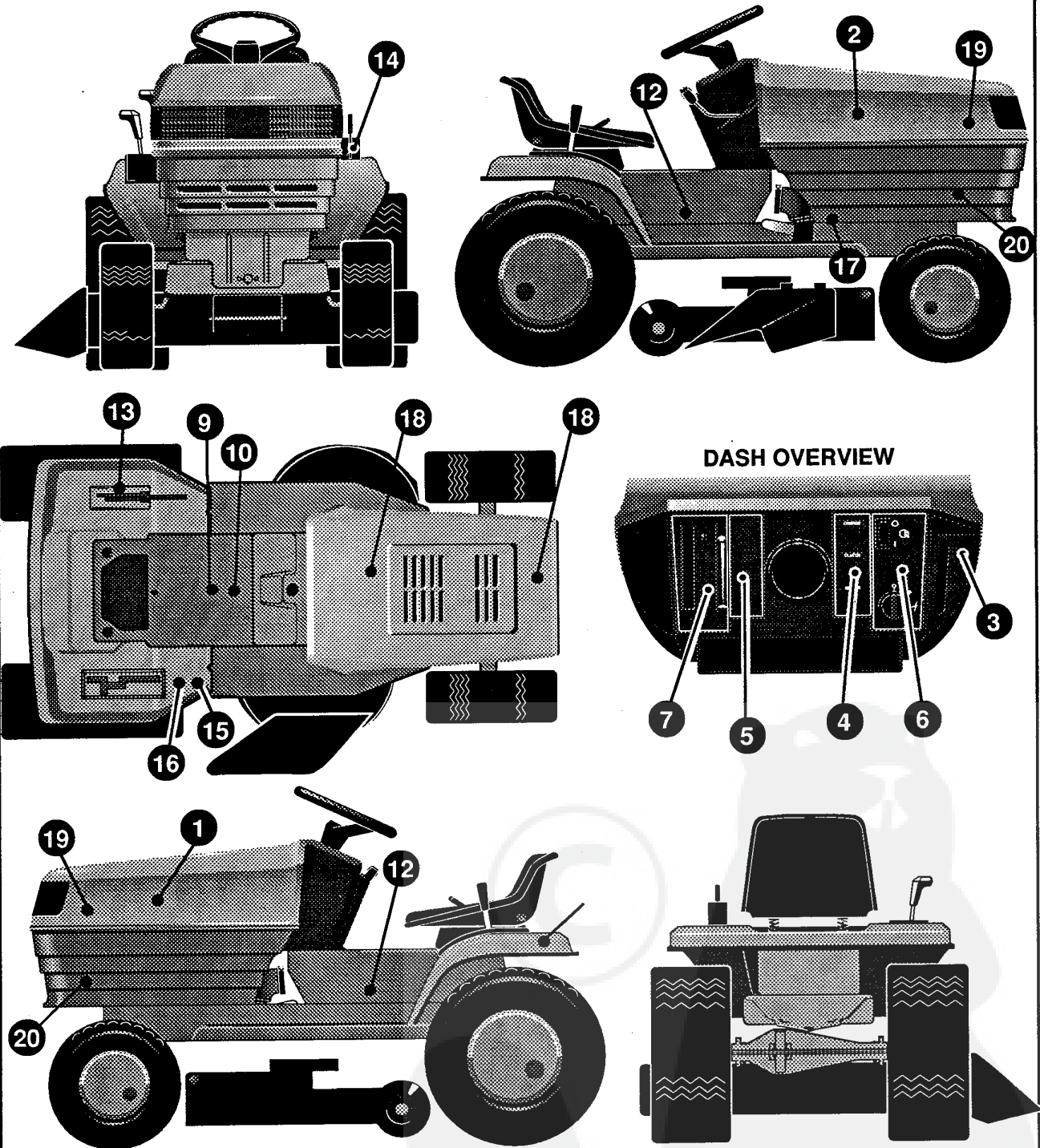

322339A

## 40" LAWN TRACTOR MODEL C3560-150

key#	part#	description	qty.
1.	323421	DECAL, 4012 SOLIFER LH	1
2.	323422	DECAL, 4012 SOLIFER RH	1
3.	68900	DECAL, BLADE ENGAGE EUROPE	1
4.	300445	DECAL, DASH RH TRANSLUCENT	1
5.	302049	DECAL, DASH LH PLAIN	1
6.	305766	DECAL, DASH, RH IGN	1
7.	305767	DECAL, DASH, LH	1
8.		REFERENCE ONLY	1
9.	301104	DECAL, CONSOLE TOP SHIFT 5-SP	1
10.	307383	DECAL, INSTR. CONSOLE TOP ENGL	1
11.		REFERENCE ONLY	1
12.	322801	NAMEPLATE 12/40 WHITE/BLACK	2
13.	68901	DECAL, BLADE HEIGHT ADJ. EUROPE	1
14.	301897	DECAL, LIFT DECK BLADE HEIGHT	1
15.	305770	DECAL, CAUTION TRIANGLE EUROPE	1
16.	310553	DECAL, DANGER ENGLISH	1
17.	68903	DECAL, BRAKE/CLUTCH ISO	1
18.	305602	FOAM HOOD 4X15	2
19.	305603	PAD, 18X6 FOAM HOOD	2
20.	305604	FOAM, HOODD 7X12	2

# 40" LAWN TRACTOR MODEL C3560-150

## CUSTOMER ASSEMBLY

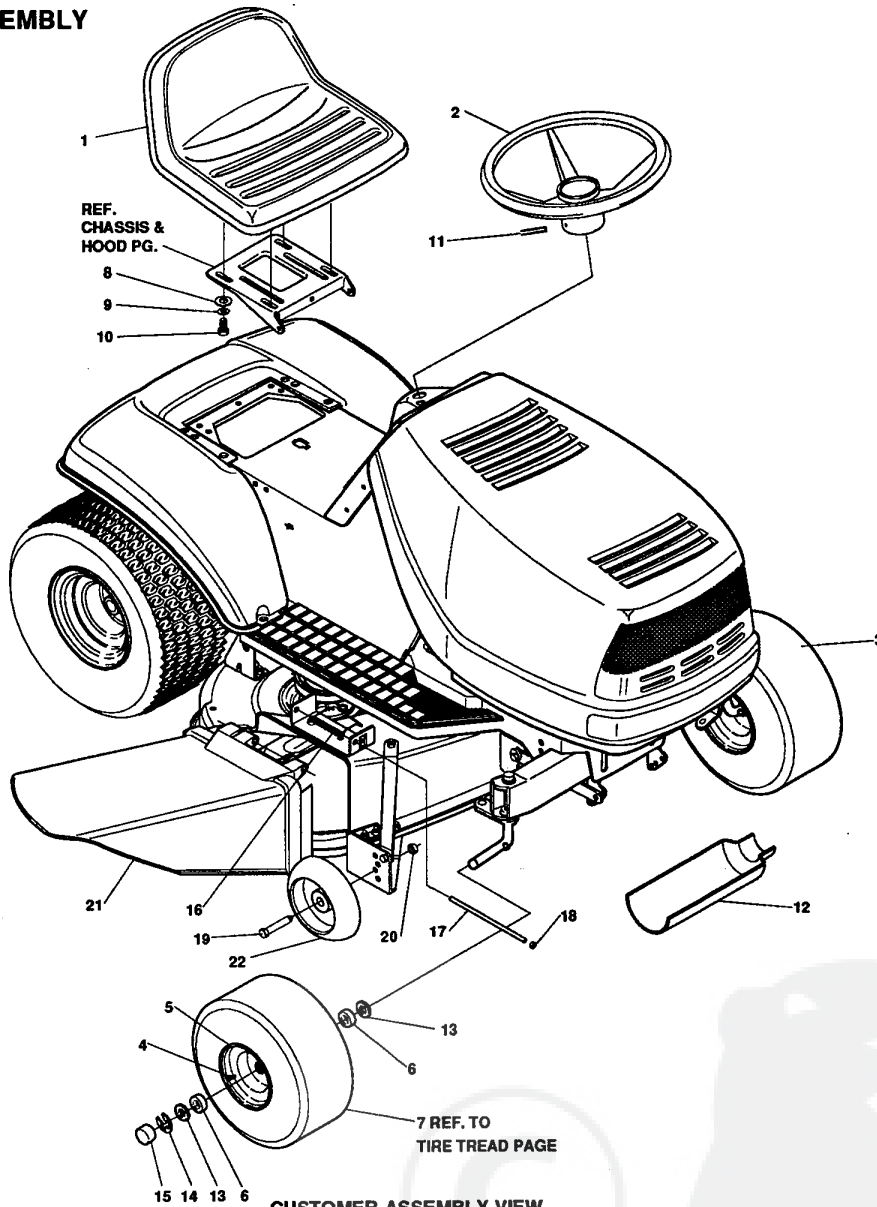

**CUSTOMER ASSEMBLY VIEW**  
322770 PARTS BAG ASSY QTY1

key#	part#	description	qty
1	57455	SEAT 550	1
2	301251	STEERING WHEEL 13" STD	1
3	*	TIRE & RIM ASSY. 15X6-6 WHITE(SEE TIRE TREAD PAGE)	2
4	24167	VALVE STEM	1
5	39829	WHEEL W/BEARINGS	1
6	39979	BEARINGS	2
7		REFER TO TIRE TREAD PAGE	
8	120393	WASHER, FLAT .344X.69X.065	4
9	120638	WASHER, HVSP TLK .328X.60X.09	4
10	122007	SCREW, 5/16-18X.75 HHC	4
11	456378	PIN, SPRING .250DIA X2.00LG	1
12	54873	OIL TROUGH	1
13	642	WASHER, FLAT .755X1.31X.075	4
14	36625	RING, RETEX	2
15	40394	HUB CAP	2
16	314975	TORSION SPRING	1
17	304424	ROD, PIVOT	1
18	3535	NUT, PUSH	1
19	23763	BOLT, .500X1.390 HHS 3/8-16	2
20	1499	NUT, 3/8-16 REGHXCTRLK	2
21	304422	CHUTE DEFLECTOR	1
22	302611	DECK WHEEL	2

322771A

# TREAD PATTERNS

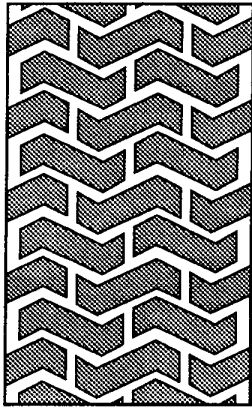

**"A"**

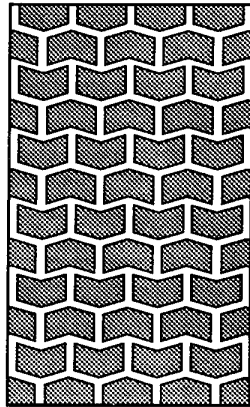

**"B"**

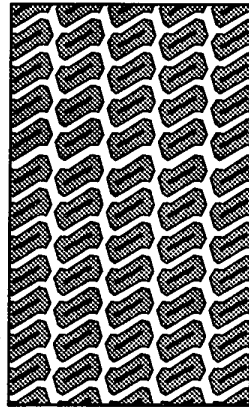

**"C"**

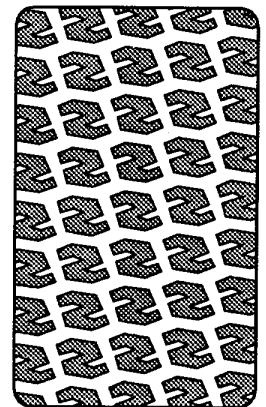

**"D"**

TIRE SIZE	"A"	"B"	"C"	"D"
11 X 4.00 - 5	42295	319679		
13 X 5.00 - 6	41060	319680		
15 X 6.00 - 6	39830	316702	301140	313952
16 X 6.50 - 8	41081	319682		314539
18 X 8.50 - 8	319683	317400		
18 X 9.50 - 8	41106	316701		313950
20 X 8.00 - 8	319685	319684	57164	314584
20 X 10.00 - 8	58276	319686		313654
20 X 10.00 - 10	55893	319687		
23 X 9.50 - 12	53655	319690	319689	314370

## ACCESSORIES

**Contact the dealer where your tractor was purchased for the available accessories. If you are unable to contact the dealer, write to the address on the front cover of this manual.**

### Rear Engine Rider

Model	Description
5708-16	Bagger - Fits 32" Side Discharge
5708-17	Bagger - Fits 36" Side Discharge & 30" Top Discharge
5709-02	Front Weight Box - holds 35 lbs.
5648-16	Lawn Sweeper w/dump Release
5714-00	Mulching Kit - 30" Top Discharge

### Lawn Tractor

Model	Description
5708-22	Bagger - Fits 30" Side Discharge
5708-13	Bagger - Fits 36", 38", 39" & 45" Side Discharge
5705-04	36" Two-Stage Snowblower - Fits 36", 38", 39", & 45" Side Discharge
5661-06	42" Snowblade - Fits 36", 38", 39", & 45"
5592-00	Tire Chains - 18" x 6.50"
5585-00	Tire Chains - 18" x 9.50" & 20" x 8"
5672-01	Wheel Weights - Front - 1 pr. w/mtg. hdw. - Fits 15" tires
5673-02	Wheel Weights - Rear - 1 pr. w/mtg. hdw. - Fits 18" & 20" tires
5709-03	Front Weights - Fits 30" & 32" Side Discharge
5648-16	Lawn Sweeper w/dump Release
5714-00	Mulching Kit - 30" Top Discharge

### Garden Tractor - Light Ground Engaging

Model	Description
5708-13	Bagger - Fits 36", 38", 39", & 45" Side Discharge
5705-04	36" Two - Stage Snowblower - Fits 36", 38", 39", & 45"
5661-06	42" Snowblade - Fits 36", 38", 39", & 45"
5672-01	Wheel Weights - Front 1 pr. w/mtg. hdw. - Fits 15" tires
5673-02	Wheel Weights - Rear - 1 pr. w/mtg. hdw. - Fits 18" & 20" tires
5648-16	Lawn Sweeper w/dump Release
5667-02	Sleeve Hitch - w/lift bar - Fits 45"
5668-01	Adaptor (sleeve hitch) for use w/23" tires
5706-00	Tire Chains - 20" x 10"
5671-00	Tire Chains - 23" x 9.50"
5672-02	Wheel Weights - Front - 1 pr. w/mtg. hdw. Fits 16" tires
5673-00	Wheel Weights - Rear - 1 pr. w/mtg. hdw. Fits 23" tires
5674-01*	10" One Bottom Moldboard Plow
5675-01*	Cultivator - 7 row - Adj. 6" - 42" width
5676-01*	Disc Harrow - 8" & 11" disc - Adj. width & disc angle
5677-02*	Tiller - 5 H.P. Self-Powered - 28" width

### Four Wheel Steer

Model	Description
5708-14	Bagger - Fits 40" & 46" Side Discharge
5705-05	42" One-Stage Snowblower - Fits 40" & 46"
5661-07	48" Snowblade - Fits 40" & 46"
5709-04	Rear Weight Box for 40" & 46"
5648-16	Lawn Sweeper w/dump Release
5706-00	Tire Chains 20" x 10"
5671-00	Tire Chains 23" x 9.50"
5672-02	Wheel Weights - Front - 1 pr. w/mtg. hdw. Fits 16" tires
5673-00	Wheel Weights - Rear - 1 pr. w/mtg. hdw. Fits 23" tires
5672-01	Wheel Weights - Front - 1 pr. w/mtg. hdw. Fits 15" tires
5673-02	Wheel Weights - Rear - 1 pr. w/mtg. hdw. Fits 18" & 20" tires

### Two Wheel Steer Garden Tractor

Model	Description
5667-04	Sleeve Hitch - w/lift bar Fits 46"
5674-01*	10" One Bottom Moldboard Plow
5675-01*	Cultivator - 7 row - Adj. 6" - 42" width
5676-01*	Disc Harrow 8" & 11" Disc. Adj. width & disc angle
5677-02*	Tiller 5 H.P. Self-Powered - 28" width
5648-16	Lawn Sweeper w/dump Release

\*Requires a sleeve hitch