

REPAIR PARTS MANUAL

42" - 18 H.P. LAWN TRACTOR

MODEL C3560-690

TWO YEAR LIMITED WARRANTY

For two (2) years from date of purchase by the first consumer for residential use (thirty (30) days commercial use), NOMA Outdoor Products Incorporated warrants that it will replace free of charge, including labor, any original part of any NOMA Outdoor Products Incorporated product found to be defective by any authorized Service Dealer or the factory, except the battery which is warranted for ninety (90) days from date of purchase.

This warranty does not cover engine, transmission, transaxle or differential (these items are covered by their manufacturer's own warranty). This warranty does not cover parts that have failed due to normal wear or parts that have failed subject to misuse or abuse. Transportation of the unit or part to and from an authorized Service Dealer or factory is the responsibility of the owner.

A step by step explanation as to what procedure should be followed for this warranty is:

1. If a part becomes defective, contact the store where the unit was purchased for the name and address of the authorized Service Dealer nearest to you.
2. If you cannot locate an authorized Service Dealer, write Service Department of NOMA Outdoor Products Incorporated for the name and address of the authorized Service Dealer in your area or call the Service Department at 1-901-422-1690.
3. Return the defective product, along with proof of purchase to such authorized Service Dealer for replacement of any defective part where covered by this warranty.

There is no other express warranty. Implied warranties, including those of merchantability and fitness for a particular purpose are limited to two (2) years from date of purchase. Liability for incidental or consequential damages are excluded.

Some states do not allow limitations on how long an implied warranty lasts, so the above limitation may not apply to you. Some states do not allow the exclusion of incidental or consequential damages, so the above exclusion may not apply to you. This warranty gives you specific legal rights, and you may have other rights which vary from state to state.

NOMA Outdoor Products Incorporated

Caller 8000

Jackson, TN 38308-8000

UNIT PARTS AND SERVICE

Fill in and mail the registration card packed with the unit. For service other than covered in this manual, contact an authorized service dealer. A nationwide parts and service organization has been established to provide locally available parts and service. When ordering repair parts, always give the following information: 1. The Part Name; 2. The Part Number; 3. The Quantity desired; 4. The Full (eight digit) Model Number of the unit. The model number will be found on a plate attached to the unit.

Look for this symbol.



It means - **ATTENTION! BECOME ALERT! A HAZARD TO OPERATOR, BYSTANDER, PROPERTY OR EQUIPMENT MAY EXIST.**

NOMA Outdoor Products Incorporated
Caller 8000
Jackson, TN 38308-8000

Part No. 324770B /D

9/92



SAFETY RULES

THESE INSTRUCTIONS ARE FOR YOUR PROTECTION. PLEASE READ THEM CAREFULLY.



IMPORTANT

THIS CUTTING MACHINE IS CAPABLE OF AMPUTATING HANDS AND FEET AND THROWING OBJECTS. FAILURE TO OBSERVE THE FOLLOWING SAFETY INSTRUCTIONS COULD RESULT IN SERIOUS INJURY OR DEATH.

I. GENERAL OPERATION:

- Know controls and how to stop quickly.
- Read, understand, and follow all instructions in the manual and on the machine before starting.
- Only allow responsible adults, who are familiar with instructions, to operate the machine.
- Wear safety glasses or eye shields when assembling or operating the machine.
- Do not operate machine when barefooted. Always wear substantial footwear, preferably steel-toed shoes.
- Do not wear loose fitting clothing that could get caught in moving parts.
- Clear the area of objects such as rocks, toys, wire, etc., which could be picked up and thrown by the blade(s).
- Be sure the area is clear of other people before mowing. Stop machine if anyone enters the area.
- Never carry passengers.
- Do not mow in reverse unless absolutely necessary. Always look down and behind before and while backing.
- Be aware of the mower discharge direction and do not point it at anyone. Do not operate the mower without either the entire grass catcher or the guard in place.
- Slow down before turning.
- Never leave a running machine unattended. Always turn off blades, set parking brake, stop engine, and remove keys before dismounting.
- Turn off blade(s) when not mowing.
- Stop engine before removing grass catcher or unclogging chute.
- Mow only in daylight or good artificial light.
- Do not operate the machine while under the influence of alcohol or drugs.
- Watch for traffic when operating near or crossing roadways.
- Use care when mowing around a fixed object to prevent the blade(s) from striking it. Never deliberately run over any foreign object.
- Use extra care when loading or unloading the machine into a trailer or truck.
- Use care when pulling loads or using heavy equipment.
 - a. Use only approved drawbar hitch points.
 - b. Limit loads to those that you can safely control.
 - c. Do not turn sharply. Use care when backing.
 - d. Use counterweight(s), wheel weight or tire chains when suggested in attachment(s) instructions.

II. SLOPE OPERATION:

Slopes are a major factor related to loss-of-control and tip-over accidents, which can result in severe injury or death. *All slopes require extra caution.* If you cannot back up the slope or if you feel uneasy on it, do not mow it.

DO

- Mow up and down slopes, not across.
- Remove obstacles such as rocks, tree limbs, etc.
- Watch for holes, ruts, or bumps. Uneven terrain could overturn the machine. *Tall grass can hide obstacles.*
- Use slow speed. Choose a low gear so that you will not have to stop or shift while on the slope.
- Follow the manufacturer's recommendations for wheel weights or counterweights to improve stability.
- Use extra care with grass catchers or other attachments. These can change the stability of the machine.
- Keep all movement on the slopes *slow and gradual*. Do not make sudden changes in speed or direction.
- Avoid starting or stopping on a slope. If tires lose traction, turn off the blade(s) and proceed slowly *straight* down the slope.

DO NOT

- Do not turn on slopes unless necessary, and then slowly and gradually downhill, if possible.
- Do not mow near drop-offs, ditches or embankments. The

mower could suddenly turn over if a wheel is over the edge of a cliff or ditch, or if an edge caves in.

- Do not mow on wet grass. Reduced traction could cause sliding.
- Do not try to stabilize the machine by putting your foot on the ground.
- Do not use grass catcher on steep slopes.

III. CHILDREN:

Tragic accidents can occur if the operator is not alert to the presence of children. Children are often attracted to the machine and the mowing activity. *Never assume that children will remain where you last saw them.*

- Keep children out of the mowing area and under the watchful care of another responsible adult.
- Be alert and turn machine off if children enter the area.
- Before and when backing, look behind and *down* for small children.
- Never carry children. They may fall off and be seriously injured or interfere with safe machine operation.
- Never allow children to operate the machine.
- Use extra care when approaching blind corners, shrubs, trees, or other objects that may obscure vision.

IV. SERVICE:

- Use extra care in handling gasoline and other fuels. They are flammable and vapors are explosive.
 - a. Use only an approved container.
 - b. Never remove gas cap or add fuel with the engine running. Allow engine to cool before refueling. Do not smoke.
 - c. Never refuel the machine indoors.
 - d. Never store the machine or fuel container inside where there is an open flame, such as in a water heater.
- Check fuel supply before each use allowing space for expansion as the heat of the engine and/or sun can cause gasoline to expand and overflow the tank.
- Use extra care when handling battery acid. Acid contact with skin may cause severe burns. Eye contact may cause blindness.
- Use extra care when servicing the battery. Explosive gas is produced in the battery. Do not service the battery while smoking or near an open spark or flame. This may cause the battery to explode causing serious injury.
- Never run a machine inside a closed area. Exhaust fumes contain CARBON MONOXIDE, an ODORLESS and DEADLY GAS.
- Keep nuts and bolts, especially blade attachment bolts, tight and keep equipment in good condition.
- Never tamper with safety devices. Check their operation regularly.
- Do not change the engine governor settings or overspeed engine.
- Reduce fire hazards. Keep machine free of grass, leaves, or other debris build-up. Clean up oil or fuel spillage. Allow machine to cool before storing.
- Stop and inspect the equipment if you strike an object. Repair, if necessary, before restarting.
- Never make adjustments or repairs with the engine running.
- Grass catcher components are subject to wear, damage, and deterioration, which could expose moving parts or allow objects to be thrown. Frequently check components and replace with manufacturer's recommended parts, when necessary.
- Mower blade(s) are sharp and can cut. Wrap the blade(s) or wear gloves, and use extra caution when servicing them.
- Check brake operation frequently. Adjust and service as required.



LOOK FOR THIS SYMBOL TO POINT OUT IMPORTANT SAFETY PRECAUTIONS. IT MEANS--ATTENTION!!! BECOME ALERT!!! YOUR SAFETY IS INVOLVED.

OWNER'S INFORMATION

Record the following information about your unit so that you will be able to provide it in case of loss or theft.

MODEL NUMBER: - (Enter complete 8 digit number from model plate on unit)
PURCHASE DATE: ___ / ___ / ___ CODE NO.: _____ SERIAL NO.: _____
DEALER'S NAME AND ADDRESS: _____
CITY: _____ STATE: _____ TELEPHONE: _____

CONTENTS OF SHIPPING CARTON

- 1 - Lawn Tractor with 42 inch Mower Deck
- 1 - Operator's Manual
- 1 - Repair Parts Manual
- 1 - Engine Manual
- 1 - Steering Wheel (see Note)
- 1 - Seat (see Note)
- 1 - Chute Deflector
- 2 - Deck Wheels
- 2 - Front Tires
- 1 - Bag of Assembly Parts Containing (see Note):
 - 1 - Oil Drain Trough
 - 1 - Steering Shaft Cover (Steering Wheel Assembly)
 - 1 - Spring Pin (Steering Wheel Assembly)
 - 4 - 5/16 x 3/4 inch Hex Head Screws (Seat Assembly)
 - 4 - 5/16 inch Split Lockwashers (Seat Assembly)
 - 4 - 11/32 inch Flatwashers (Seat Assembly)
 - 1 - Torsion Spring (Chute Deflector Assembly)
 - 1 - Pivot Rod (Chute Deflector Assembly)
 - 1 - Push-On Nut (Chute Deflector Assembly)
 - 2 - 3/8-16 Hex Head Shoulder Bolts (Mower Deck Wheels Assembly)
 - 2 - 3/8-16 Reg Hex Centerlock Nuts (Mower Deck Wheels Assembly)
 - 1 - Shift Knob
 - 4 - 3/4 inch Flat Washers (Front tire assembly)
 - 2 - Retex Rings (Front tire assembly)
 - 2 - Hub Caps (Front tire assembly)

NOTE: Refer to pages 24 & 25 (Customer Assembly Parts) for more detailed description.

TOOLS REQUIRED FOR ASSEMBLY

- 2 - 7/16 Inch Wrenches (or adjustable wrench)
- 1 - 9/16 inch Wrench (or adjustable wrench)
- 1 - 3/4 inch Wrench (or adjustable wrench)
- 1 - 1/2 inch Wrench (or adjustable wrench)
- 1 - Small Phillips Screwdriver with a 1/4 inch shank
- 1 - Hammer

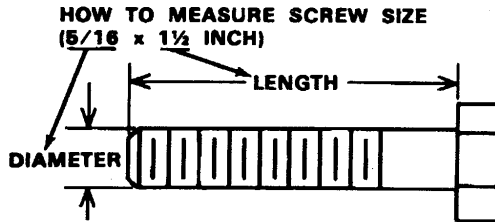

DANGER



This lawn tractor can be dangerous if carelessly used.

Read your Operator's Manual thoroughly before operating your lawn tractor.

Always wear safety glasses or eye shields while assembling or operating your lawn tractor.

DO NOT carry passengers at any time.

Keep your hands, feet, hair and loose clothing away from the discharge area, the underside of the mower deck or any moving parts while the engine is running.

DO NOT allow children or young teenagers to operate or be near your lawn tractor while it is operating.

ALWAYS GIVE THE FOLLOWING INFORMATION WHEN ORDERING REPAIR PARTS:
1. The PART NUMBER; 2. The PART NAME; 3. QUANTITY DESIRED; 4. The MODEL NUMBER (As shown on Model Plate).
SEND PART ORDERS AS PER INSTRUCTIONS ON THE FRONT PAGE.
DO NOT USE KEY NUMBERS WHEN ORDERING REPAIR PARTS, ALWAYS USE PART NUMBERS.
All replacement parts will be supplied in current production colors or in a neutral color.
A handling fee is applicable to small parts orders.
YOUR UNIT IS RIGHT HAND (RH) OR LEFT HAND(LH) AS YOU STAND BEHIND IT.

42" LAWN TRACTOR MODEL C3560-690

CHASSIS & HOOD ASSEMBLY

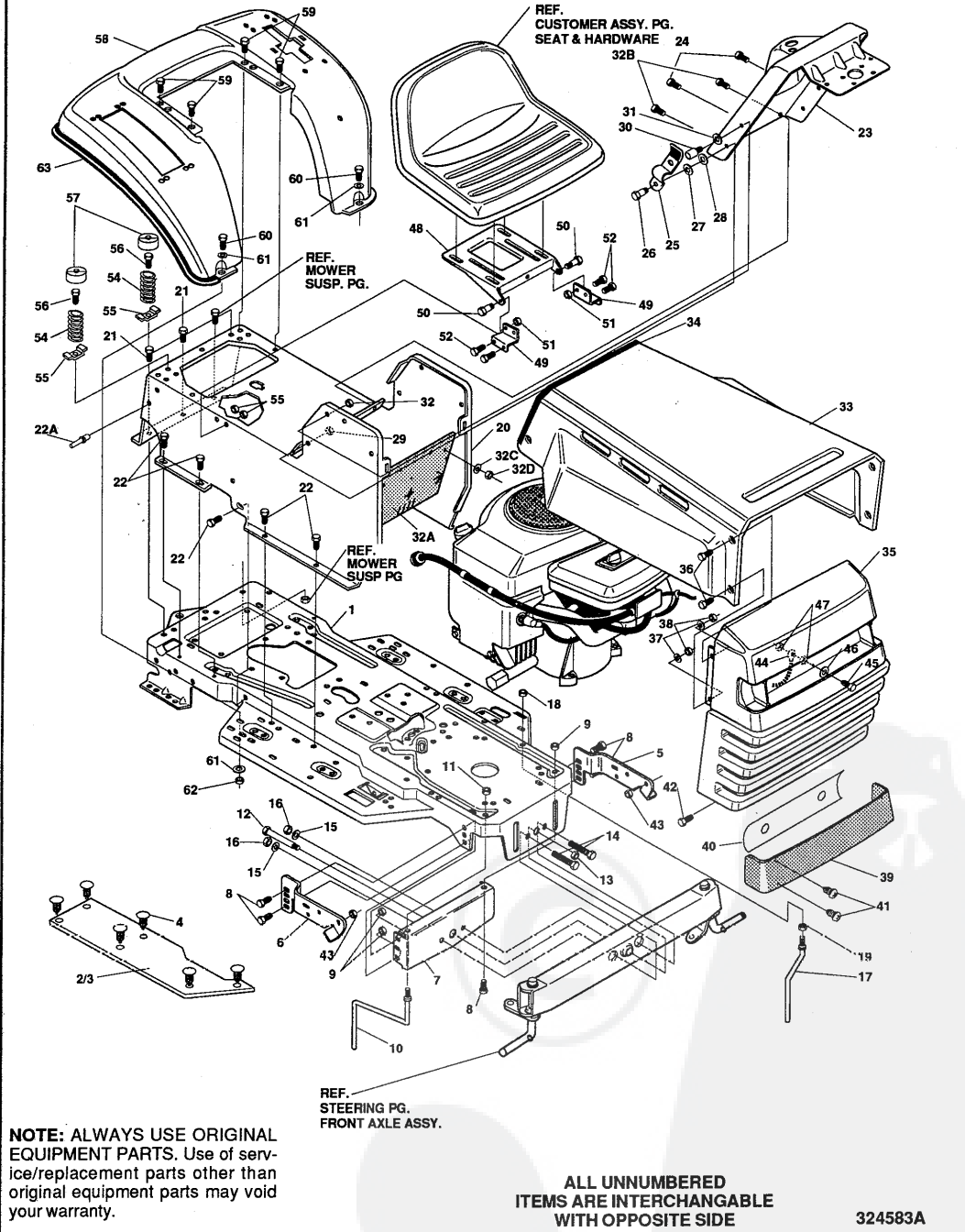

42" LAWN TRACTOR MODEL C3560-690

key#	part#	description	qty.
1	321708-860	FRAME,LF MAIN P920/F4360	1
2	310005	FOOTPAD,LH 22.12LG DYNA F-5	1
3	310006	FOOTPAD,RH 22.12LG DYNA F-5	1
4	309235	FASTENER, RATCHET	12
5	313001-853	BRKT,GRILL LH	1
6	313002-853	BRKT,GRILL RH	1
7	313541-853	BRACKET, FRONT AXLE	1
8	56030	SCREW, 5/16-18X.75WDFLLK GR5	5
9	55273	NUT, 5/16-18 HXWDFLLK	5
10	300440	GUIDE, BELT, RIDER	1
11	◊1498	NUT, 5/16-18 REGHEXCTRLK	1
12	308207	BOLT, .625X2.18 HSSH 1/2-13	1
13	309008	NUT, 1/2-13 HEXJAM CTRLK	1
14	◊122207	SCREW, 3/8-16X3.00 HHC GR2	2
15	2483	WASHER,.39IDX1.25DX.07 BELLVIL	2
16	◊1499	NUT, 3/8-16 REGHXCTRLK	2
17	300635	GUIDE,BELT SHORT 15" WHEEL	1
18	◊124824	NUT, 5/16-18 HEXJAM	1
19	◊271190	NUT, 3/8-16 HEXKEPS	1
20	308665-860	CONSOLE LF SOF	1
21	35497	SCREW, 5/16-18X .50 WAHHTAP	2
22	995346	SCREW, 1/4-20X .50 WAHHTAP	12
22A	46763	RIVET, POP	1
23	309447-860	DASHBOARD,LF SUSP DYNA	1
24	995346	SCREW, 1/4-20X .50 WAHHTAP	2
25	57159	LATCH, .94WDX.047 ASSY HOOD	2
26	8482	BOLT, .375X .156 HSSH 5/16-18	2
27	120394	WASHER, FLAT .406X .81X.065	2
28	120393	WASHER, FLAT .344X .69X.065	2
29	◊1498	NUT, 5/16-18 REGHEXCTRLK	2
30	53446	PIN, 5/16-18 HOOD LATCH GR2-	2
31	138538	WASHER, REGINTLK.320X.61X.03	2
32	45174	NUT, 5/16-18 HEXWDFLLK WHIZ	2
32A	312306	BAFFLE, CONSOLE SOUND, EXPORT	1
32B	300314	SCREW, 14-20 X .88 WAHHTAP	2
33C	120392	WASHER, FLAT .281 X .63 X .065	2
32D	1502	NUT, 1/4-20 REGHEXCTRLK	2
33	314537-860	HOOD, LF H-20 DYNA/PRO	1
34	47453	EDGING,WIDE BLK	27.5"
35	314476	GRILLE DYNA-PRO G-17	1
36	◊274672	SCREW, 1/4-20X .63 WAHHC GR2	4
37	120392	WASHER, FLAT .281X .63X.065	4
38	◊1502	NUT, 1/4-20 REGHEXCTRLK	4
39	302333	LENS, SMOKED W/TAB NO LOGO	1
40	314948	FOIL,LENS DYNA-PRO REFLECTOR	1
41	57796	SCREW, #6 X .50 PLASTITE/HI-LO	4
42	36149	BOLT, .375X .500 HSSH 5/16-18	2
43	◊1498	NUT, 5/16-18 REGHEXCTRLK	2
44	310748	LANYARD,HOOD 15.77LG H15	1
45	◊48900	SCREW, 1/4-20X1.00 WAHHC GR2	1
46	120392	WASHER, FLAT .281X .63X.065	1
47	◊1502	NUT, 1/4-20 REGHEXCTRLK	2
48	58367-853	PLATE, SEAT F-5 SF & LF	1
49	310660-853	BRACKET, F-5 SEAT SUPPORT	1
50	20507	BOLT, .437X .156 HSSH 5/16-18	2
51	◊1498	NUT, 5/16-18 REGHEXCTRLK	2
52	◊48901	SCREW, 5/16-18X .63 HHC	4
53	◊1498	NUT, 5/16-18 REGHEXCTRLK	4
54	57153	SPRING,SEAT 2.63LG.1.49OD	2
55	1341	CLAMP,SPRING 1.17"ID ZPL	2
56	44811	SCREW, 1/4-20X .75 HXWATAP	2
57	56907	COVER,SEAT SPRING 1.5IDX1.0LG	2
58	308653-860	FENDER, F-5 SUSP LF, SOF	1
59	995346	SCREW, 1/4-20X .50 WAHHTAP	4
60	◊122017	SCREW, 5/16-18X1.00 HHC GR2	2
61	446363	WASHER, FLAT .375X .88X.082	4
62	◊1498	NUT, 5/16-18 REGHEXCTRLK	2
63	55021	TRIM,STRIP,BLACK—SMALL, W/ ADH	75"
64	324767	OPERATOR'S MANUAL, ENGLISH (NOT SHOWN)	1
65	324768	OPERATOR'S MANUAL, FRENCH (NOT SHOWN)	1
66	324769	OPERATOR'S MANUAL, GERMAN (NOT SHOWN)	1
67	324770	OPERATOR'S MANUAL, ENGLISH (NOT SHOWN)	1

◊ Indicates STANDARD HARDWARE ITEMS.

42" LAWN TRACTOR MODEL C3560-690

MOWER SUSPENSION ASSEMBLY

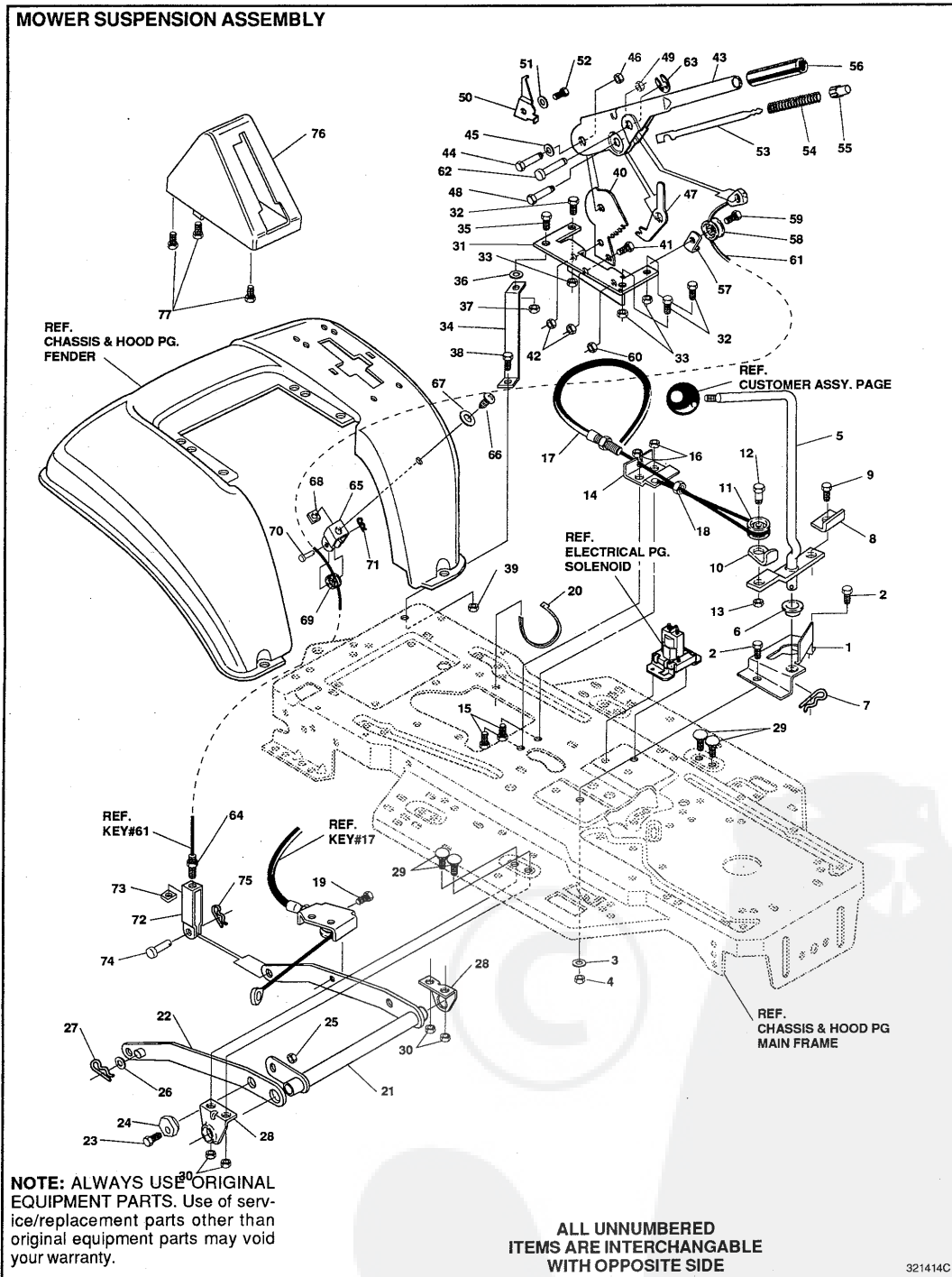

NOTE: ALWAYS USE ORIGINAL EQUIPMENT PARTS. Use of service/replacement parts other than original equipment parts may void your warranty.

ALL UNNUMBERED ITEMS ARE INTERCHANGABLE WITH OPPOSITE SIDE

321414C

42" LAWN TRACTOR MODEL C3560-690

key#	part#	description	qty.
1	320075-853	BRACKET,CLUT-ENGAGELEVER	1
2	180079	◇ SCREW, 5/16-18X1.00 HHC	2
3	120393	WASHER, FLAT .344X .69X.065	2
4	1498	◇ NUT, 5/16-18 REGHEXCTRLK	2
5	304791	ASSY,CLUTCH LEVER	1
6	50148	BEARING,FL. .503IDX.628OD	1
7	8260	PIN, HAIR .091 DIA X1.66LG	1
8	318341	BRACKET,SWITCH ENGAGE	1
9	35498	◇ SCREW, 5/16-18X .75 WAHHTAP	1
10	1288	BRKT,CABLE RETAINER	1
11	48306	PULLEY, .906X.305 PM	1
12	58336	BOLT, .375X .375 HSSH 1/4-20	1
13	1502	◇ NUT, 1/4-20 REGHEXCTRLK	1
14	300698-853	BRKT, FRAME CABLE	1
15	180020	◇ SCREW, 1/4-20X .75 HHC	2
16	1502	◇ NUT, 1/4-20 REGHEXCTRLK	2
17	301503	ASSY,CABLE, BLADE ENGAGE	1
18	120613	◇ NUT, 1/4-28 HJAM	1
19	35498	◇ SCREW, 5/16-18X .75 WAHHTAP	1
20	57444	TIE, CABLE BLACK NYLON	1
21	300158-853	ASSY,REAR LIFT	1
22	300169-853	ASSY.LINK,RIGHT SIDE	1
23	180079	◇ SCREW, 5/16-18X1.00 HHC	1
24	58247	ADJUSTING NUT	1
25	1498	◇ NUT, 5/16-18 REGHEXCTRLK	1
26	417098	WASHER, FLAT .531X1.06X.095	2
27	8260	PIN, HAIR .091 DIA X1.66LG	2
28	58248-853	BRKT,REAR,HANG,SUSP.	2
29	126211	BOLT, 5/16-18X .63 CARR	4
30	1498	◇ NUT, 5/16-18 REGHEXCTRLK	4
31	58333	BRACKET,HGT/ADJUST SUPPORT	1
32	180077	◇ SCREW, 5/16-18X .75 HHC	3
33	1498	◇ NUT, 5/16-18 REGHEXCTRLK	3
34	300336	BRACE, FENDER F-5 SUS	1
35	180079	◇ SCREW, 5/16-18X1.00 HHC	1
36	45602	WASHER, FLAT .333X .87X.119	1
37	1498	◇ NUT, 5/16-18 REGHEXCTRLK	1
38	180079	◇ SCREW, 5/16-18X1.00 HHC	1
39	1498	◇ NUT, 5/16-18 REGHEXCTRLK	1
40	301238	QUADRANT,HEIGHT ADJUST	1
41	180077	◇ SCREW, 5/16-18X .75 HHC	2
42	1498	◇ NUT, 5/16-18 REGHEXCTRLK	2
43	303026-853	HANDLE,LIFT SHORT BLK	1
44	300171	BOLT, .500X .270 HSSH 5/16-18	1
45	996418	WASHER, FLAT .506X .75X.024	1
46	44108	◇ NUT, 5/16-18 HWDFLCTRLK	1
47	301239	PAWL, HEIGHT ADJUST	1
48	300171	BOLT, .500X .270 HSSH 5/16-18	1
49	44108	◇ NUT, 5/16-18 HWDFLCTRLK	1
50	9435	POINTER Z-PL	1
51	138479	WASHER, EXLK .195X.41X.03	1
52	35287	◇ SCREW, #8-32X .38 HHWAT	1
53	303027	ROD,ACTUATOR-SHORT	1
54	58326	SPRING, HEIGHT ADJUST	1
55	58325	KNOB, HGT ADJ PUSH BUTTON	1
56	58329	GRIP .750 OD W/ HOLE	1
57	9149	BRKT, CABLE RETAIN	1
58	39298	PULLEY, .906X.305 NYLON	1
59	58336	BOLT, .375X .375 HSSH 1/4-20	1
60	1502	◇ NUT, 1/4-20 REGHEXCTRLK	1
61	314177	CABLE, LIFT 23.30 F-5 20X8-8	1
62	300310	PIN,CLEVIS .310DIA+.475LG	1
63	300311	RING, RET E .31X.24	1
64	120375	◇ NUT, 1/4-20 REGHEX	1
65	300298	CLEVIS	1
66	439455	◇ SCREW, 5/16-18X .56PHPNMA BKPH	1
67	301551	WASHER,.344IDX1.50DX.09 CU BPH	1
68	120373	◇ NUT, 5/16-18 SQ	1
69	39298	PULLEY, .906X.305 NYLON	1
70	300317	PIN, CLEVIS .38 DIA X1.00 LG	1
71	8260	PIN, HAIR .091 DIA X1.66LG	1
72	9405	CLEVIS, LIFT CABLE	1
73	120372	◇ NUT, 1/4-20 HEGSQ	1
74	39522	PIN CLEVIS .312 X .812	1
75	121222	PIN, COTTER .090/.086X.75LG	1
76	300335	LIFT COVER-39" F5	1
77	300340	◇ SCREW, #10 X .75 HHPLAST	3

◇ STANDARD HARDWARE ITEMS.

42" LAWN TRACTOR MODEL C3560-690

STEERING ASSEMBLY

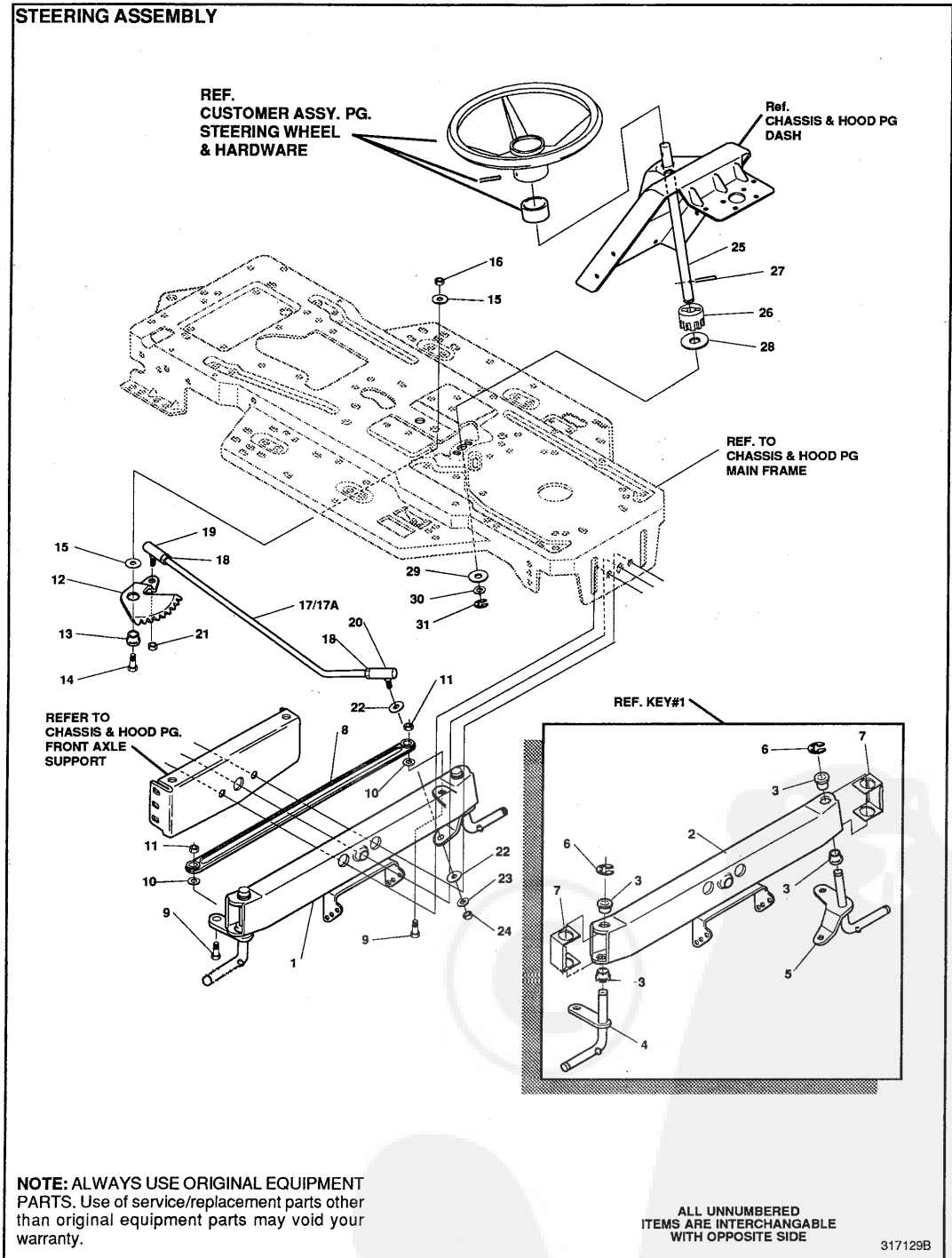

42" LAWN TRACTOR MODEL C3560-690

key#	part#	description	qty.
1	*	AXLE,FRONT ASSY SUS LF	1
2	300272	ASSY FRONT AXLE SUSPENDE	1
3	52407	SPINDLE BEARING	4
4	9180	ASSY,SPINDLE,RH	1
5	314088	ASSY,SPINDLE,LH	1
6	36625	RING, RETEX .57X.05TRU5133-75	2
7	53373	AXLE COVER	2
8	304590	TIE ROD ASSY 19.81LG	1
9	◇180128	SCREW, 3/8-16X1.75 HHC	2
10	120382	WASHER, REGSPTLK.393X.68X.10	2
11	◇1499	NUT, 3/8-16 REGHXCTRLK	2
12	58289	SECTOR, STEERING LF	1
13	52406	BRNG,FL ECC.510IDX .998ODX .56	1
14	180177	SCREW, 1/2-13X1.50 HHC	1
15	22265	WASHER, FLAT .515X1.38X.119PL	2
16	◇1500	NUT, 1/2-13 REGHXCTRLK	1
17	300146	SF DRAGLINK ASSY .5 DIA	1
17A	58291	STEERING LINK	1
18	◇124925	NUT, 3/8-24 REGHEXJAM	2
19	57158	BALL JOINT 3/8 THD SHORT STUD	1
20	21275	BALL JOINT 3/8 TH'D LONG STUD	1
21	◇46692	NUT, 3/8-24 WDFHLK WHIZ	1
22	◇120396	WASHER, FLAT .531X1.06X.095	2
23	◇120382	WASHER, REGSPTLK.393X.68X.10	1
24	◇120369	NUT, 3/8-24 REGHEX	1
25	58243	SHAFT, STEERING LF	1
26	58244	PINION, STEERING LF	1
27	58274	PIN,DOWEL .2500 OD+1.75LG	1
28	301410	BRNG, FL .752IDX1.061ODX .24	1
29	301398	WASHER, FORMED1.135X1.53X.12	1
30	◇21682	WASHER, FLAT .765X1.25X.042	1
31	36625	RING, RETEX .57X.05TRU5133-75	1

* Order Individual Parts.

◇ Indicates STANDARD HARDWARE ITEMS.

42" LAWN TRACTOR MODEL C3560-690

MOTION DRIVE ASSEMBLY

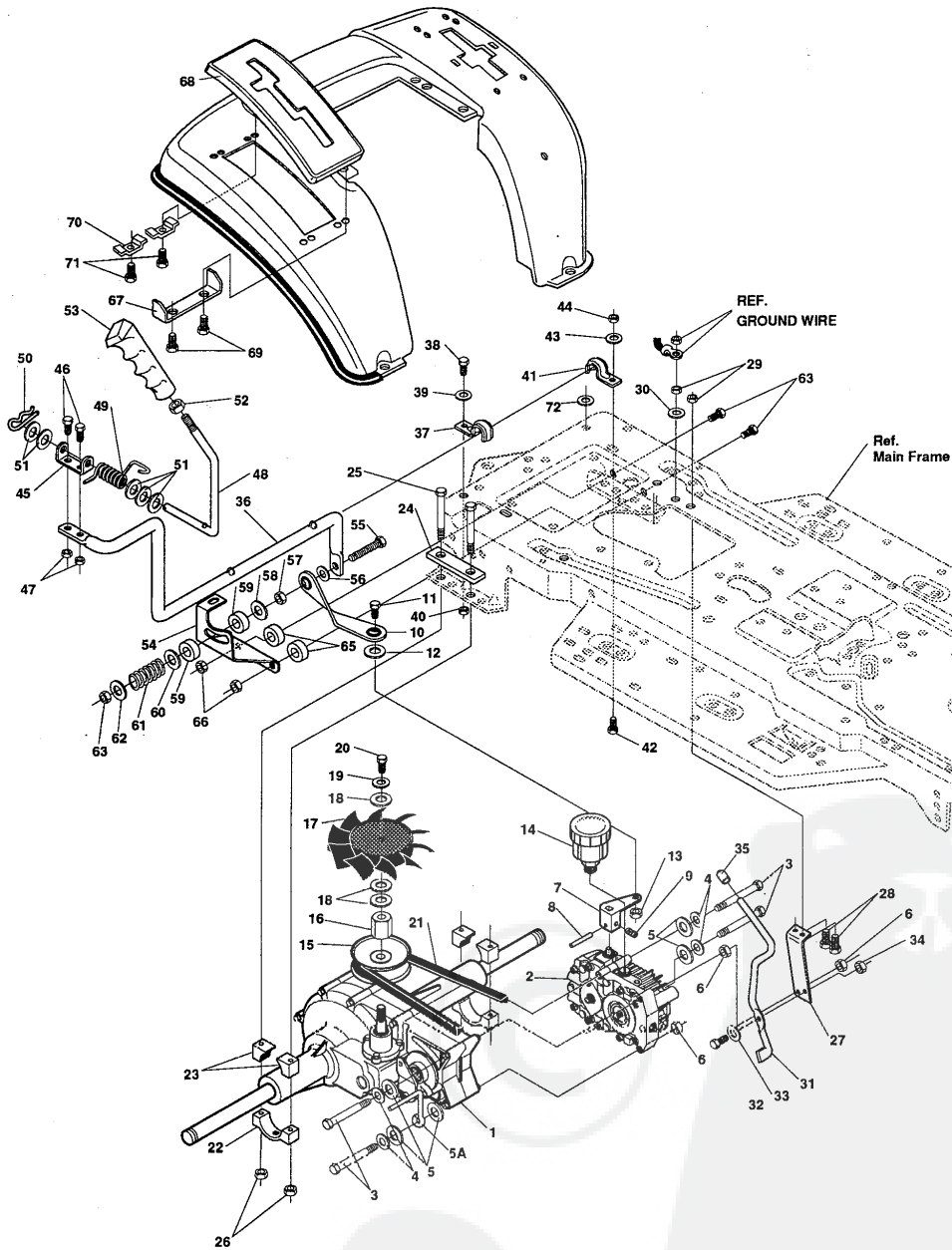

NOTE: ALWAYS USE ORIGINAL EQUIPMENT PARTS.
Use of service/replacement parts other than original equipment parts may void your warranty.

**ALL UNNUMBERED
ITEMS ARE INTERCHANGABLE
WITH OPPOSITE SIDE**

319941D

42" LAWN TRACTOR MODEL C3560-690

key#	part#	description	qty.
1	~	TRANSAXLE, AGRIFAB HYDRO	1
2	310227	HYDROSTATIC PUMP BDU-10S-114	1
3	◊ 189299	SCREW, 5/16-18X4.50 HHC	4
4	◊ 120638	WASHER, HVSP TLK .328X.60X.09	4
5	◊ 120393	WASHER, FLAT .344X .69X.065	5
5A	55480	BELT GUIDE	1
6	◊ 1498	NUT, 5/16-18 REGHEXCTRLK	3
7	310180	ARM SPEED CONTROL HYDRO	1
8	456652	PIN, SPRING.187DIA X .88LG	1
9	◊ 102570	SCREW, 1/4-20X .38 ALHSETCPPT	1
10	314236	LINK, SHIFT LF HYDRO	1
11	◊ 122145	SCREW, 3/8-16X1.25 HHC	1
12	◊ 120382	WASHER, REGSPLTLK .393X.68X.10	1
13	◊ 1499	NUT, 3/8-16 REGHXCTRLK	1
14	310786	RESERVIOR, HYDRO	1
15	310098	PULLEY ASSY HYDRO	1
16	310094	NUT PULLEY 1/2-20 AND 1/4-20	1
17	308523	FAN, HYDRO 7.00DIA. 10 BLADES	1
18	◊ 908492	WASHER, FLAT .28X1.38X.07	3
19	◊ 120380	WASHER, REGSPTLK.263X.49X.07	1
20	◊ 180018	SCREW, 1/4-20X .62 HHC	1
21	314572	BELT, V 4L 80.16 HYDRO LF	1
22	310187	MOUNTING BLOCKS HYDRO	2
23	310813	MOUNTING BLOCK LH HYDRO	4
24	313371	PLATE GUIDE	2
25	◊ 180112	SCREW, 5/16-18X2.75 HHC	4
26	◊ 1498	NUT, 5/16-18 REGHEXCTRLK	4
27	314221	STABILIZER BRACKET LF HYDRO	1
28	◊ 122017	SCREW, 5/16-18X1.00 HHC	2
29	◊ 1498	NUT, 5/16-18 REGHEXCTRLK	2
30	138538	WASHER, REGINLK .320X.61X.03	1
31	314222	ROD-DUMP VALVE LF HYD.ZINC	1
32	310088	BOLT, .250X .312 HSH 5/16-18	1
33	◊ 2483	WASHER, .39ID X 1.25DX.07 BELLVIL	1
34	◊ 1502	NUT, 1/4-20 REGHEXCTRLK	1
35	7289	RUBBER STOP	1
36	314281-853	LEVER, SHIFT-LWR LF HYDRO	1
37	310347-853	CLIP-SHIFT LEVER .62 ROD	1
38	◊ 180077	SCREW, 5/16-18X .75 HHC	1
39	◊ 996416	WASHER, FLAT .391X1.00X.125	1
40	◊ 1498	NUT, 5/16-18 REGHEXCTRLK	1
41	310347-853	CLIP-SHIFT LEVER .62 ROD	1
42	180077	SCREW, 5/16-18 REGHEXCTRLK	1
43	◊ 996416	WASHER, FLAT .391X1.00X.125	1
44	◊ 1498	NUT, 5/16-18 REGHEXCTRLK	1
45	310356	PIVOT BRKT LEVER BLACK	1
46	◊ 180018	SCREW, 1/4-20X .62 HHC	2
47	◊ 1502	NUT, 1/4-20 REGHEXCTRLK	2
48	318452	LEVER, SHIFT UPPER SF 1/2-13TH	1
49	318451	SPRING, TORS. .56X.95X.095	1
50	8260	PIN, HAIR .125 DIA X 1.00 LG	1
51	2968	WASHERS	5
52	◊ 120238	NUT, 1/2-13 HEXJAM	1
53	306690	HANDLE 1/2-13 MOLDED BLACK 173	1
54	314473-853	QUADRANT, SPEED CONTROL	1
55	7288	SCREW, 3/8-16X3.00 HHCFT	1
56	120382	WASHER, REGSPLTLK .393-16X3.00	1
57	◊ 45171	NUT, 3/8-16 HWD FL WHIZ NUT	1
58	◊ 845	WASHER, FLAT .390X1.25X.119	1
59	314944	WASHER, FRICTION	2
60	◊ 845	WASHER, FLAT .390X1.25X.119	1
61	29170	SPRING	1
62	◊ 274517	WASHER, FLAT .406X.73X.063	1
63	◊ 1499	NUT, 3/8-16 REGIXCTRLK	1
64	◊ 180081	SCREW, 5/16-18X1.25 HHC	2
65	314702	SPACER .344 X 1.00 X .500	2
66	◊ 1498	NUT, 5/16-18 REGHEXCTRLK	2
67	311257-853	BRACKET COVER	1
68	314244	COVER PLASTIC	1
69	311331	SCREW, 174-15X.44/533 HILOHWA	2
70	1341	CLAMP SPRING	2
71	311331	SCREW, 174-15X.44/533 HILOHWA	2
72	309436	PUSHNUT, 5/16 BOLT RETAINER	1

~ See Transaxle Breakdown Pages.

◊ Indicates STANDARD HARDWARE ITEMS.

319941 C (2,5)

42" LAWN TRACTOR MODEL C3560-690

MOTION DRIVE ASSEMBLY

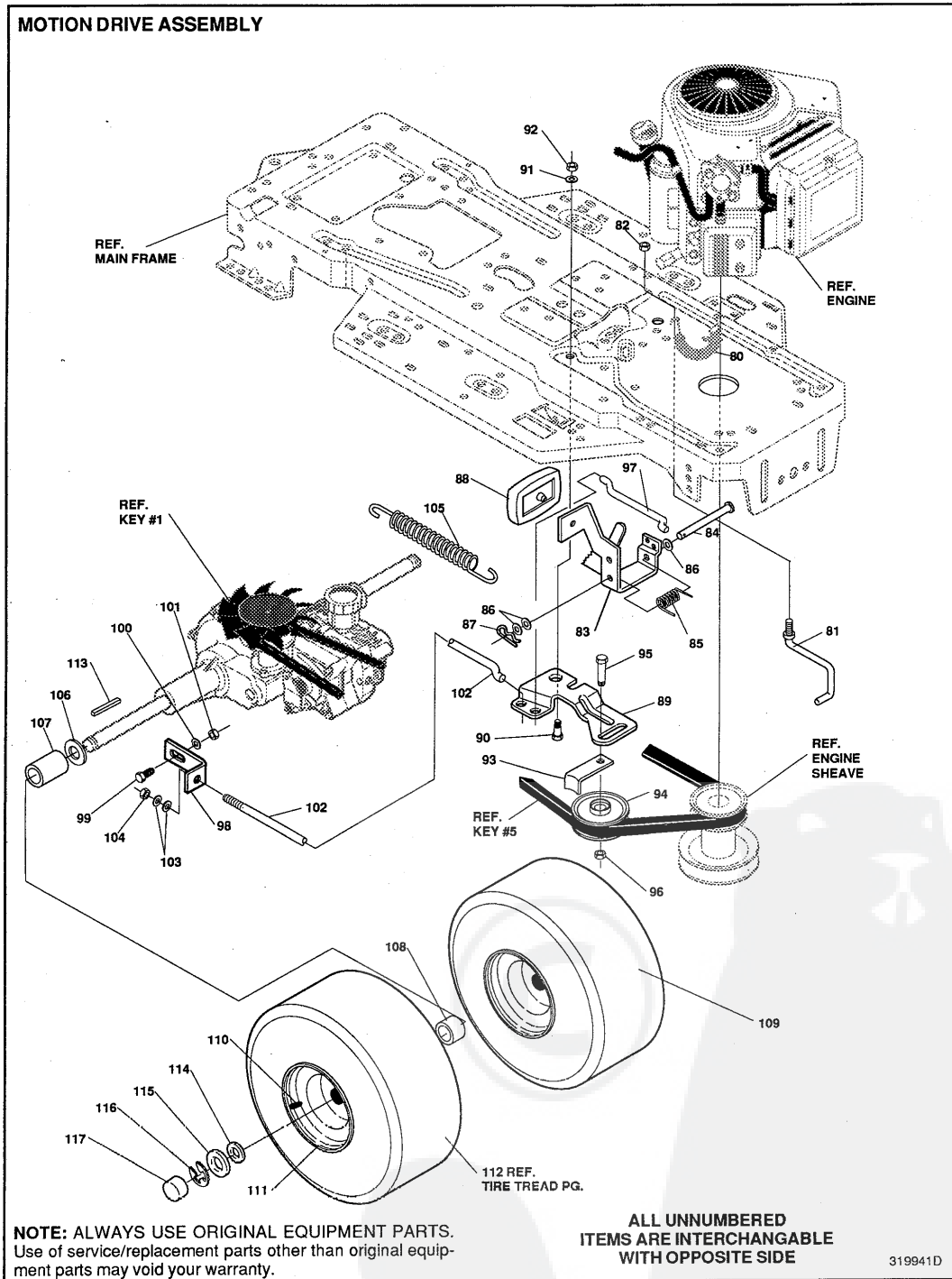

42" LAWN TRACTOR MODEL C3560-690

key#	part#	description	qty.
80	321514	SPRING BIAS DRAGLINK	1
81	304016	GUIDE BELT	1
82	1498	NUT, 5/16-18 REGHEXCTRLK	1
83	300308	PEDAL ASSY,BRAKE/CLUTCH LF	1
84	319675	PIN,CLEVIS	1
85	57847	SPRING, BRAKE PEDAL	1
86	◇ 2968	WASHER, FLAT .504X .75X.059	3
87	56180	PIN,HAIR	1
88	48160	PAD, CLUTCH BRAKE W/PRINTING	1
89	320381	ARM,IDLER TRACTION DR. LF	1
90	300793	BOLT, .625X .135 HSSH 5/16-18	1
91	◇ 45602	WASHER, FLAT .333X .87X.119	1
92	◇ 1498	NUT, 5/16-18 REGHEXCTRLK	1
93	39659	RETAINER, STRAP BELT	1
94	35374	PULLEY, IDLER V4L 3.06X .62	1
95	45892	BOLT, 3/8-16X1.50 CARR	1
96	◇ 1499	NUT, 3/8-16 REGHXCTRLK	1
97	57204	ROD, CLUTCH	1
98	57217	BRACKET, BRAKE ROD	1
99	20507	BOLT, .437X .156 HSSH 5/16-18	1
100	◇ 45602	WASHER, FLAT .333X .87X.119	1
101	◇ 1498	NUT, 5/16-18 REGHEXCTRLK	1
102	316293	ROD, BRAKE LT 920 LF 22.25	1
103	◇ 120393	WASHER, FLAT .344X.69X.065	2
104	◇ 1498	NUT, 5/16-18 REGHEXCTRLK	1
105	56359	SPRING, CLUTCH .113X.750X8.75	1
106	◇ 42815	WASHER, FLAT .755X1.53X.07	2
107	57479	SPACER, .75 X 1.25 X 1.32	2
108	301565	SPACER, SLEEVE	2
109	*	TIRE & RIM	2
110	24167	VALVE STEM	1
111	301366	RIM, WHEEL	1
112		REFER TO TIRE TREAD PAGE	
113	52928	KEY, SQUARE .187SQX2.25LG	2
114	◇ 642	WASHER, FLAT .755X1.31X.075	4
115	◇ 42815	WASHER, FLAT .755X1.53X.07	2
116	36625	RING, RETEX .57X.05TRU5133-75	2
117	40394	CAP, HUB	2

* Order Individual Parts.
 ◇ Indicates STANDARD HARDWARE ITEMS.

42" LAWN TRACTOR MODEL C3560-690

ENGINE & CONTROL ASSEMBLY

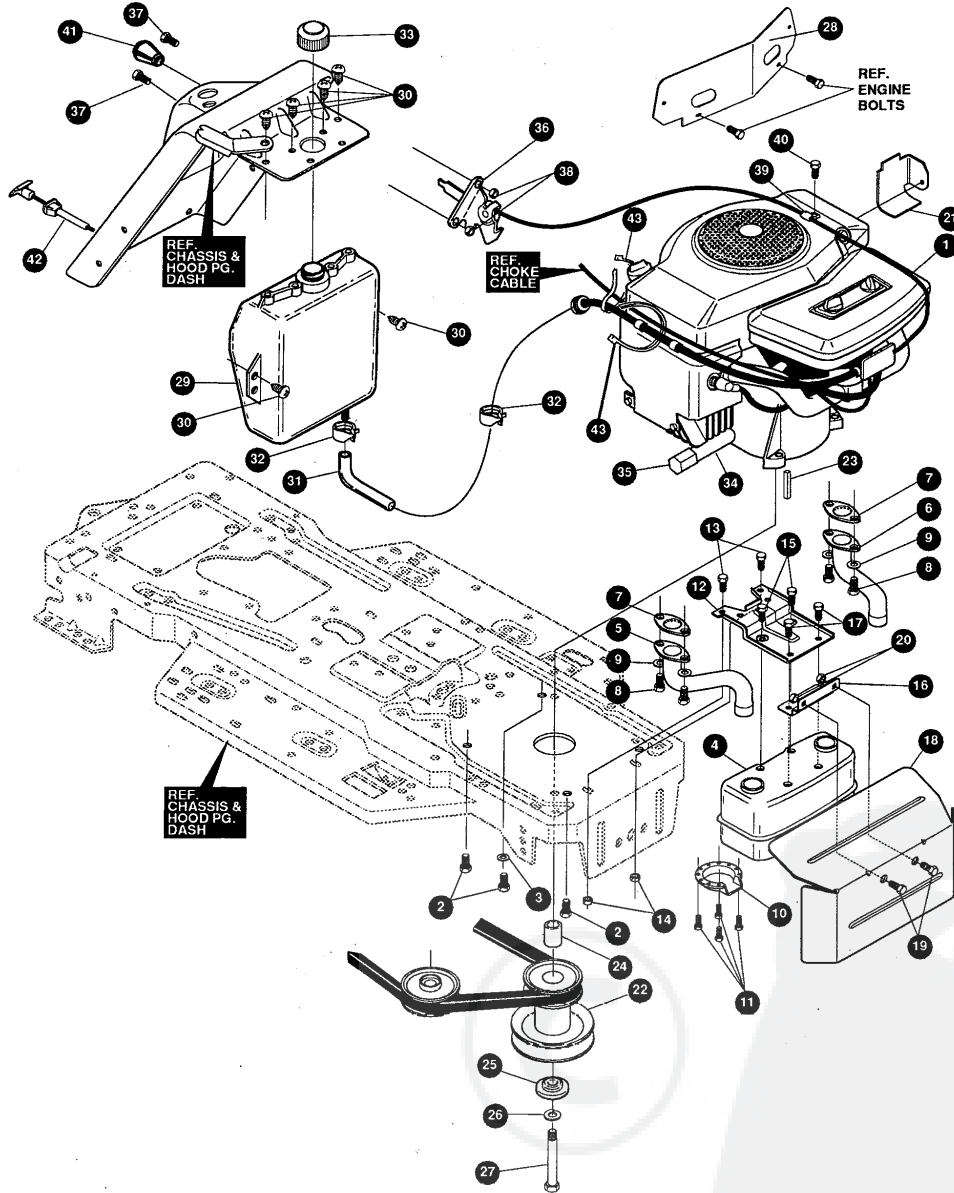

NOTE: ALWAYS USE ORIGINAL EQUIPMENT PARTS. Use of service/replacement parts other than original equipment parts may void your warranty.

ALL UNNUMBERED ITEMS ARE INTERCHANGABLE WITH OPPOSITE SIDE

324575A

42" LAWN TRACTOR MODEL C3560-690

KEY#PART#	DESCRIPTION	QTY.
1. ENGINE	SEE ENGINE MANUAL	1
2. 50947	SCREW, 3/8-16X1.25 WAHHTAPBLKP	4
3. 138489	WASHER, EXLK .384X.69X.04	1
4. 305550	MUFFLER,16/18HP LARGE LO-TONE	1
5. 305552	EXHAUST TUBE 18HP B&S RH	1
6. 305551	EXHAUST TUBE 18HP LH	1
7. 56640	GASKET, MUFFLER	2
8. 180020	SCREW, 1/4-20X .75 HHC GR5	4
9. 120380	WASHER, REGSPTLK.263X.49X.07	4
10. 56472	DEFLECTOR SIDE OUT (BS222573)	1
11. 35287	SCREW, #8-32X .38 HHWATAPGR2	4
12. 304709-853	BRACKET,MUFFLER	1
13. 56030	SCREW, 5/16-18X.75WDFLLK GR5	2
14. 55273	NUT, 5/16-18 HXWDFLLK	2
15. 995346	SCREW, 1/4-20X .50 WAHHTAP	2
16. 9796	ML BRACKET, TRANSAXLE MOUNTING	1
17. 995338	SCREW, 1/4-20X .63 HHWATAP	2
18. 308644-853	MP SHIELD,MUFFLER HEAT 18HPB&S	1
19. 180077	SCREW, 5/16-18X .75 HHC GR5	2
20. 55273	NUT, 5/16-18 HXWDFLLK	2
21. 56470-853	MP DEFLECTOR, COOL AIR	1
22. 316802	PULLEY, ENG V3L 4.40 OFFSET/5.00D	1
23. 57791	KEY, SQUARE .250SQ X 5.00LG	1
24. 304246	SPACER, SLEV1.01X1.484X	1
25. 56431	WASHER,.980IDX1.38ODX.437PILOT	1
26. 120383	WASHER, REGSPTLK.459X.78X.12	1
27. 428644	SCREW, 7/16-20X5.00 HHC GRDS	1
28. 52796-853	MP BULKHEAD, HOOD H-8	1
29. 314992	TANK, FUEL 2 GAL CLEAR	1
30. 49050	SCREW, 1/4-10X .75PHPNTAPGR2BK	6
31. 47452	TUBING, .25X.50X BULK GAS LINE	15.5"
32. 48672	CLAMP, FUEL LINE RED	2
33. 46704	CAP, GAS 1-1/2-7 THD BLK	1
34. 52404	TUBE, OIL DRAIN 3/8-18NPT X 5"	1
35. 47828	CAP, PIPE 3/8-18 NPT ZN PL	1
36. 300456	CONTROL,THROTTLE 31LG TWIN BS	1
37. 320553	SCREW, 10-24X.63PHNMA CRSS	2
38. 271166	NUT, #10-24 HEXKEPS	2
39. 56538	RETAINER, WIRE	1
40. 35258	SCREW, 10-24X.38 SLHWATAPGR2	1
41. 50607	KNOB, ROUND THROTTLE BLACK	1
42. 300432	CONTROL,CHOKE 47.13LG PAN TK	1
43. 57444	TIE, CABLE BLACK NYLON 5.62L	2

42" LAWN TRACTOR MODEL C3560-690

PRE-PAINTED DECK ASSEMBLY

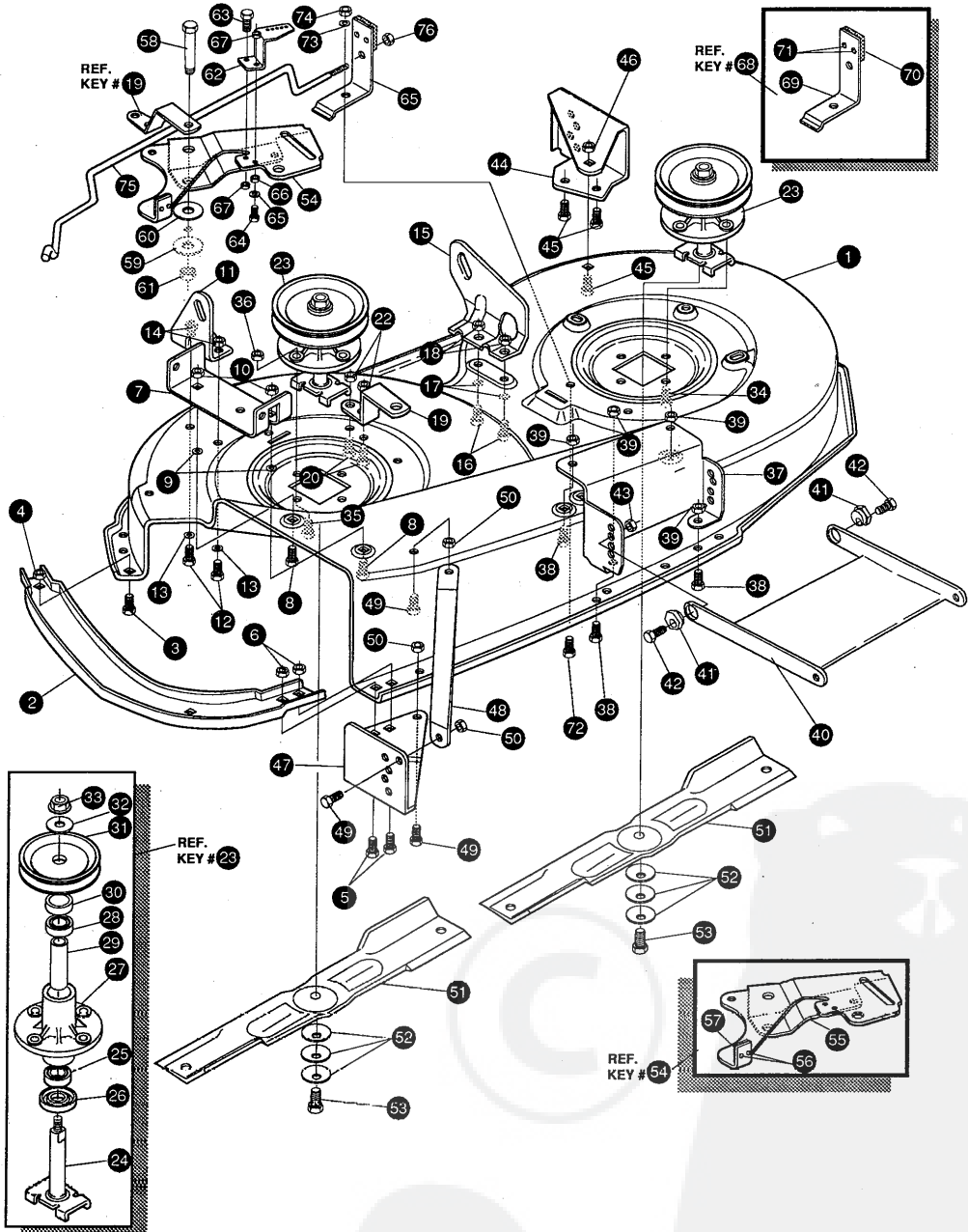

NOTE: ALWAYS USE ORIGINAL EQUIPMENT PARTS. Use of service/replacement parts other than original equipment parts may void your warranty.

ALL UNNUMBERED ITEMS ARE INTERCHANGABLE WITH OPPOSITE SIDE

324144C

42" LAWN TRACTOR MODEL C3560-690

key#	part#	description	qty.
1	322115-853	MOWER DECKS, RIDER 43"	1
2	304102	TOE GUARD	1
3	180075	SCREW, 5/16-18X .63 HHC	1
4	1498	NUT, 5/16-18 REGHEXCTRLK	1
5	122007	SCREW, 5/16-18X .75 HHC	2
6	1498	NUT, 5/16-18 REGHEXCTRLK	2
7	302364	BRACKET CHUTE MOUNT	1
8	180075	SCREW, 5/16-18X .63 HHC	2
9	120393	WASHER,FLAT .344X.69X.065	2
10	1498	NUT, 5/16-18 REGHEXCTRLK	2
11	58250	LIFT BRACKET, REAR,RH	1
12	180077	SCREW, 5/16-18X .75 HHC	2
13	120393	WASHER, FLAT .344X.69X.065	2
14	1498	NUT, 5/16-18 REGHEXCTRLK	2
15	58251	BRACKET,DECK LIFTREAR LH	1
16	180077	SCREW, 5/16-18X .75 HHC GR5	2
17	120393	WASHER, FLAT .344X.69X.065	2
18	1498	NUT, 5/16-18 REGHEXCTRLK	2
19	302363	BRACE IDLER	1
20	180077	SCREW, 5/16-18X .75 HHC	2-
22	44108	NUT, 5/16-18 HWDFLCTRLK	2
23	56424	QUILL ASSY, 36/39/40/43	2
24	56425	SHAFT/SADDLE 36"	1
25	49562	BRNG, BALL	1
26	50616	DUST SHIELD	1
27	55547	QUILL CASTING (1046)	1
28	49562	BRNG, BALL	1
29	50818	SPACER,3.797LGX.669IDX.88OD	1
30	51449	SPACER,.438LGX.932ODX.672ID	1
31	56390	PULLEY,26/36" QUILL V5L	1
32	56365	SPECIAL WASHER	1
33	1282	NUT, 7/16-20 WDFLLK	1
34	50634	SCREW, 5/16-18X .88 WAHTAP	7
35	300345	SCREW, 5/16-18X1.38 WATAP	1
36	1498	NUT, 5/16-18 REGHEXCTRLK	1
37	313778	BRACKET FRT.	1
38	180075	SCREW, 5/16-18X .63 HHC	4
39	1498	NUT, 5/16-18 REGHEXCTRLK	4
40	58305	LINK BRACKET,DECK FR	1
41	58247	ADJUSTING NUT	2
42	122017	SCREW, 5/16-18X1.00 HHC	2
43	1498	NUT, 5/16-18 REGHEXCTRLK	2
44	304426	BRACKET,GAGE WHEEL L.H.	1
45	180075	SCREW, 5/16-18X .63 HHC	3
46	1498	NUT, 5/16-18 REGHEXCTRLK	3
47	322464	BRACKET,GAGE WHEEL R.H. FRNT	1
48	314282	BRACKET,STABILIZER	1
49	180075	SCREW, 5/16-18X .63 HHC	3
50	1498	NUT, 5/16-18 REGHEXCTRLK	3
51	314369	BLADE, LOW-LIFT 21.70	2
52	2483	WASHER,.39IDX1.25DX.07 BELLVIL	6
53	39573	SCREW, 3/8-24X1.00 NYLHHC	2
54	320576	IDLER ARM ASSY	1
55	322116	IDLER ARM	1
56	41601	RIVET	2
57	306973	BRAKE PAD	1
58	304420	SHOULDER BOLT	1
59	996416	WASHER,FLAT .391X1.00X.125	1
60	996307	WASHER,FLAT .391X1.00X.209	1
61	45171	NUT, 3/8-16 HWDFL WHIZ-LOCK	1
62	300700	BRACKET, EXTENSION IDLER	1
63	180075	SCREW 5/16-18X.63 HHC GR.5	1
64.	180083	SCREW, 5/16-18X1.50 HHC GR.5	1
65.	446363	WASHER,FLAT	1
66.	271184	NUT 5/16-18 HEX KEPS	1
67	1498	NUT	2
68	321828	BLADE BRAKE ASSY	1
69	304119-053	BRAKE ARM	1
70	306973	BRAKE PAD	1
71	135624	RIVET	2
72	120228	SCREW, 5/16-18X.63	1
73	120393	WASHER,FLAT .344X.69X.065	1
74	1498	NUT, 5/16 18 REGEHEXCTRLK	1
75	314079	ROD,BRAKE	1
76	1502	NUT,1/4-20 REGHEXCTRLK	1

42" LAWN TRACTOR MODEL C3560-690

FINAL DECK ASSEMBLY

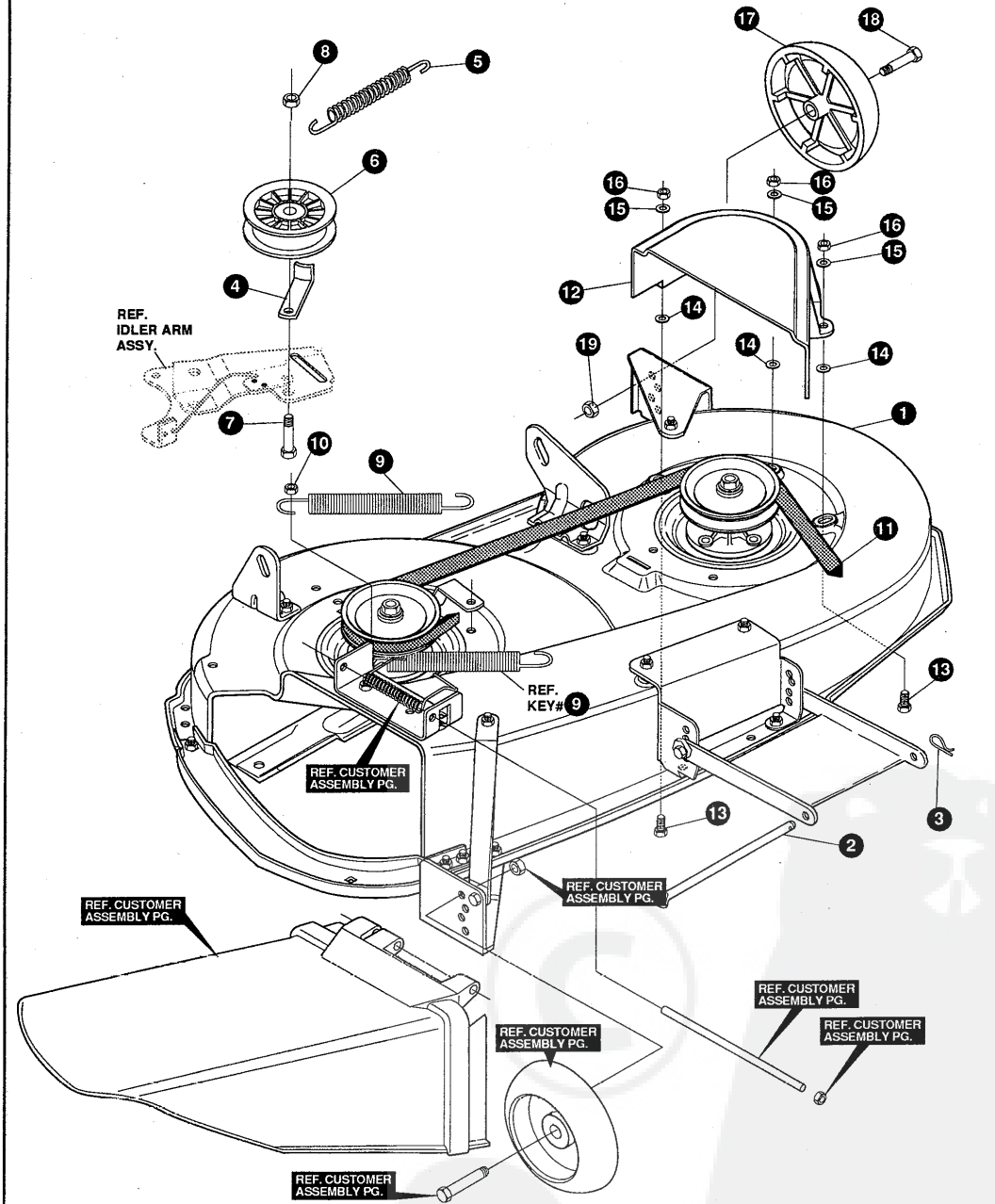

NOTE: ALWAYS USE ORIGINAL EQUIPMENT PARTS.
Use of service/replacement parts other than original equipment parts may void your warranty.

**ALL UNNUMBERED
ITEMS ARE INTERCHANGABLE
WITH OPPOSITE SIDE**

324146B

42" LAWN TRACTOR MODEL C3560-690

key#	part#	description	qty.
1	*	DECK,43" MOWER 2-WH BLACK 853 EXPORT	1
2	58306	ROD, DECK HITCH	1
3	8260	PIN, HAIR .091 DIA X 1.66LG	1
4	1346	GUIDE, BELT, IDLER	1
5	314107	SPRING, TENSION 5.00LG+17LB/IN	1
6	310326	PULLEY, IDLER BFF 4.00 WIDE FL	1
7	126416	BOLT, 3/8-16X1.75 CARR	1
8	• 44374	NUT, 3/8-16 HXWDFLLK	1
9	35410	SPRING .071 X .62 X 4.37	1
10	• 1498	NUT, 5/16-18 REGHEXCTRLK	1
11	318372	BELT, V 5L 85.00 KEVLAR	1
12	324814	GUARD, BELT LH PLASTIC	1
13	57101	CARRIAGE BOLT	3
14	309436	PUSHNUT 5/16 NON-SERVICEABLE	3
15	120393	WASHER, FLAT .344X .69X.065	3
16	• 1498	NUT, 5/16-18 REGHEXCTRLK	3

• STANDARD HARDWARE ITEMS
 * Order Individual Parts

42" LAWN TRACTOR MODEL C3560-690

ELECTRICAL ASSEMBLY

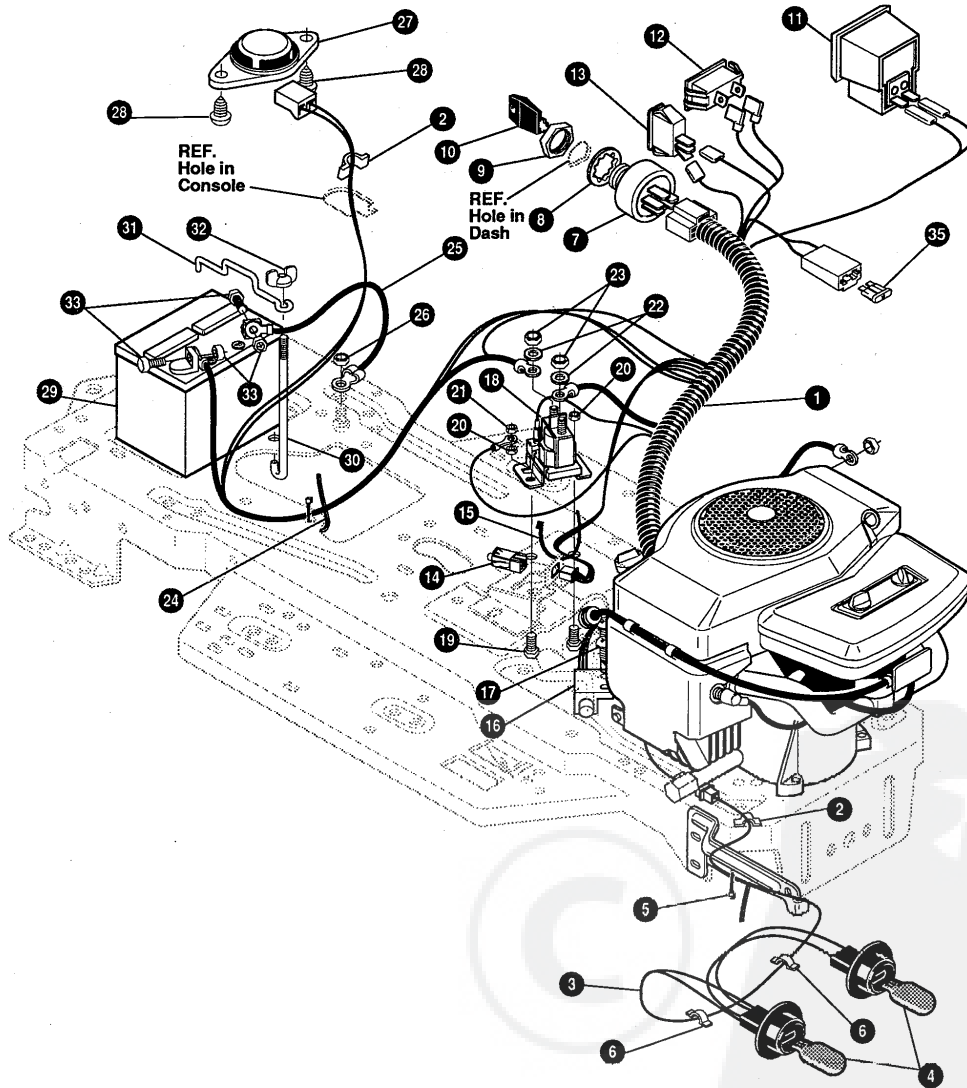

NOTE: ALWAYS USE ORIGINAL EQUIPMENT PARTS.
Use of service/replacement parts other than original equipment parts may void your warranty.

**ALL UNNUMBERED
ITEMS ARE INTERCHANGABLE
WITH OPPOSITE SIDE**

322799A

42" LAWN TRACTOR MODEL C3560-690

key#	part#	description	qty.
1.	322798	WIRE HARNESS 14-18TWIN OPP DYN	1
2.	41482	PRESS CLIP,1.380LG .255ID	2
3.	303064	ASSY,LIGHT WIRE-1/4 TURN	1
4.	52572	BULB, HEADLAMP	2
5.	57444	TIE, CABLE BLACK NYLON 5.62L	1
6.	41482	PRESS CLIP,1.380LG .255ID	2.
7.	305720	SWITCH-IGN.(AFTER FIRE) 3 POSN	1
8.	138557	WASHER, REGINTLK.640X1.1X.05	1
9.	48140	NUT, 5/8-32 HXHD IGN SWIT	1
10.	300626	KEY, IGNITION SWITCH	1
11.	300133	AMMETER	1
12.	300255	LIGHT,INDICATOR PANEL MNT	1
13.	300334	LIGHT SWITCH ON/OFF PANEL MNT	1
14.	320082	SWITCH,DOUBLE POLE NO/NC BLACK	1
15.	57444	TIE, CABLE BLACK NYLON 5.62L	1
16.	57476	SWITCH,SCR MNT DP NC NO BLK	1
17.	57220	SCREW, #12 X .50 PHPNHTAP BLK	2
18.	53716	SOLENOID	1
19.	187745	SCREW, 1/4-20X .75 HXSEMMA	2
20.	1502	NUT, 1/4-20 REGHEXCTRLK	2
21.	271172	NUT, 1/4-20 REGHEXKEPS	1
22.	138485	WASHER, EXLK .320X.61X.03	2
23.	120368	NUT, 5/16-24 REGHEX	2
24.	57444	TIE, CABLE BLACK NYLON 5.62L	1
25.	55511	WIRE, GROUND, 12.5"	1
26.	271184	NUT, 5/16-18 HEXKEPS	1
27.	57547	SWITCH, SEAT	1
28.	160505	SCREW, 1/4-20X .38PHPNHMAGR2	2
29.	302257	BATTERY 12V 7 PLATE	1
30.	57551	ROD, BATTERY	1
31.	57552	ROD, BATTERY, TOP	1
32.	310067	NUT, WING 1/4-20 SMALL PLASTIC	1
33.	120854	SCREW, 1/4-20X .63 HHC GR2	2
34.	271172	NUT, 1/4-20 REGHEXKEPS	2

WIRING SCHEMATIC

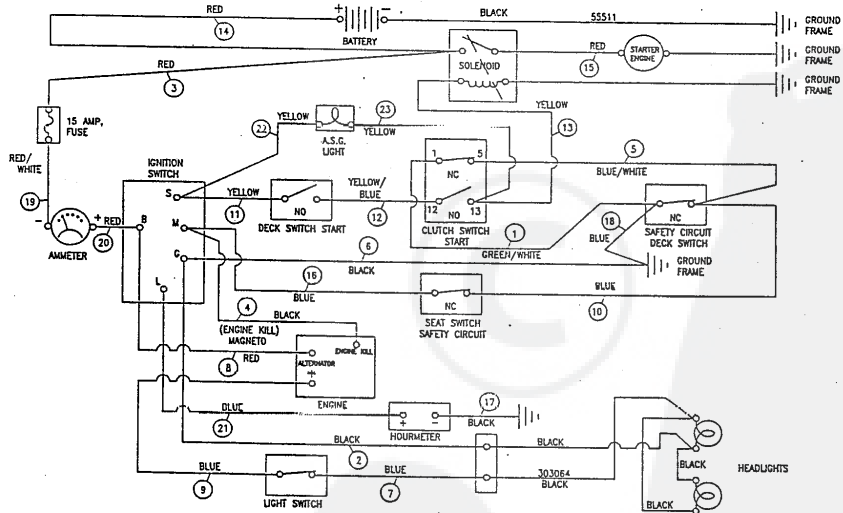

42" LAWN TRACTOR MODEL C3560-690

DECALS

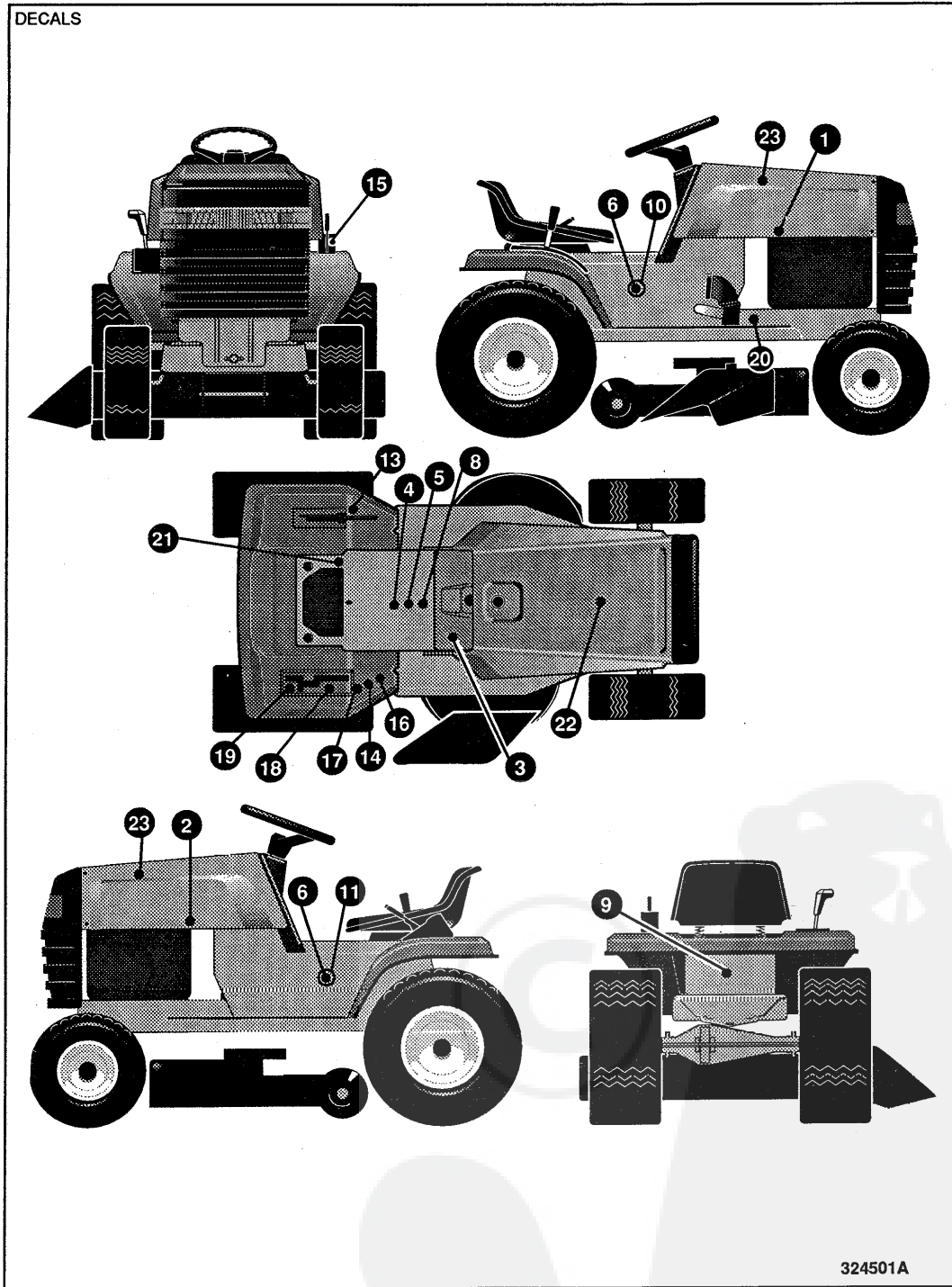

324501A

42" LAWN TRACTOR MODEL C3560-690

key#	part#	description	qty.
1.	314456	DECAL, HOODSIDE RH H-21	1
2.	314457	DECAL, HOODSIDE LH H-21	1
3.	320681	DECAL, LF DASH EXPORT	1
4.	69524	DECAL,INSTRUCT CONSOLE TOP GER	1
5.	69525	DECAL,INSTRUCT CONSOLE TOP FR	1
6.	300562	NAME PLATE, 18/42	2
7.		REFERENCE ONLY	1
8.	307383	DECAL,INSTR. CONSOLE TOP ENGL	1
9.	310436	DECAL,FRENCH SAFETY CERT.	1
10.	314462	DECAL, CONSOLE RH LARGE FRAME	1
11.	314463	DECAL, CONSOLE LH LARGE FRAME	1
12.		REFERENCE ONLY	1
13.	68901	DECAL,BLADE HEIGHT ADJ. EUROPE	1
14.	68902	DECAL,WARNING,FRENCH/GERMAN	1
15.	301897	DECAL, LIFT DECK BLADE HEIGHT	1
16.	305770	DECAL,CAUTION TRIANGLE EUROPE	1
17.	310553	DECAL,DANGER ENGLISH	1
18.	314923	DECAL SHIFTER LF HYDRO FORWARD	1
19.	314925	DECAL SHIFT LF HYDRO REVERSE	1
20.	68903	DECAL,BRAKE/CLUTCH EUROPE	1
21.	316861	DECAL, RELIEF VALVE OPERATION	1
22.	55835	PAD, FOAM HOOD TOP H-6/7	1
23.	55836	PAD, FOAM HOOD SIDE H-6/7	2

42" LAWN TRACTOR MODEL C3560-690

CUSTOMER ASSEMBLY

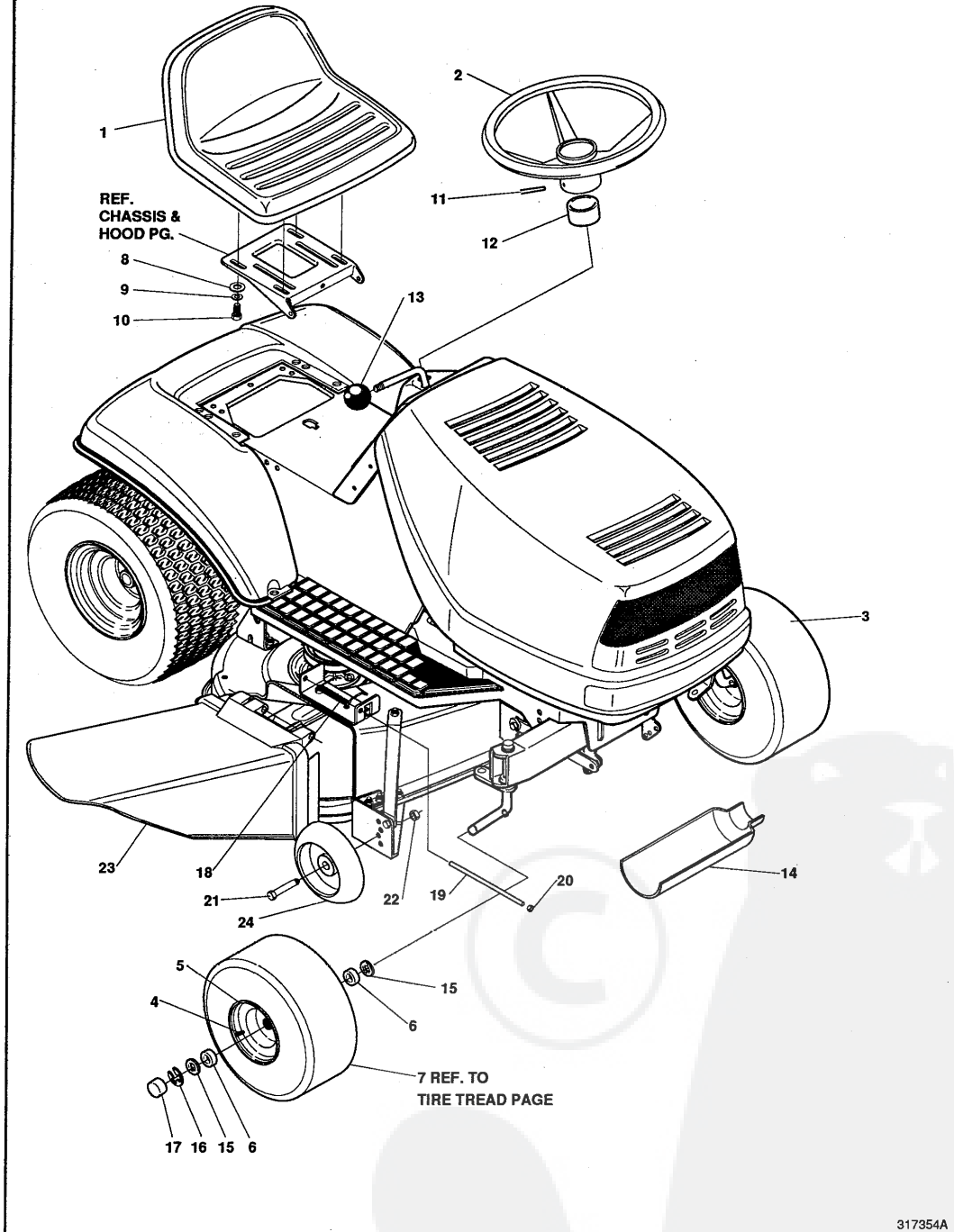

42" LAWN TRACTOR MODEL C3560-690

CUSTOMER ASSEMBLY VIEW

317355 PARTS BAG ASSY QTY1

key#	part#	description	qty
1	57455	SEAT MV450	1
2	301251	STEERING WHEEL 13" STD	1
3	*	TIRE & RIM ASSY. 15X6-6 WHITE	2
4	24167	VALVE STEM	1
5	39829	WHEEL W/BEARINGS	1
6	39979	BEARINGS	2
7		REFER TO TIRE TREAD PAGE	
8	120393	WASHER, FLAT .344X.69X.065	4
9	120638	WASHER, HVSP TLK .328X.60X.09	4
10	122007	SCREW, 5/16-18X.75 HHC	4
11	456378	PIN, SPRING .250DIA X2.00LG	1
12	57212	COVER, STEERING SHAFT	1
13	55514	KNOB, SHIFT	1
14	54873	OIL TROUGH	1
15	642	WASHER, FLAT .755X1.31X.075	4
16	36625	RING, RETEX	2
17	40394	HUB CAP	2
18	314975	TORSION SPRING	1
19	304424	ROD, PIVOT	1
20	3535	NUT, PUSH	1
21	23763	BOLT, .500X1.390 HSSH 3/8-16	2
22	1499	NUT, 3/8-16 REGHXCTRLK	2
23	304422	CHUTE DEFLECTOR	1
24	302611	DECK WHEEL	2

* Order Individual Parts.

317354A

TREAD PATTERNS

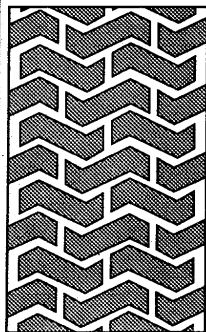

"A"

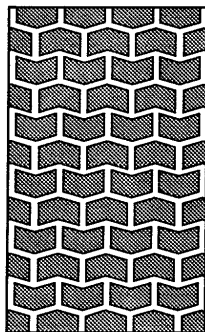

"B"

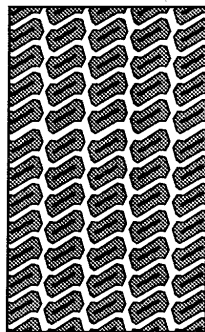

"C"

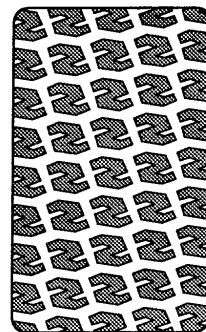

"D"

TIRE SIZE	"A"	"B"	"C"	"D"
11 X 4.00 - 5	42295	319679		
13 X 5.00 - 6	41060	319680		
15 X 6.00 - 6	39830	316702	301140	313952
16 X 6.50 - 8	41081	319682		314539
18 X 8.50 - 8	319683	317400		
18 X 9.50 - 8	41106	316701		313950
20 X 8.00 - 8	319685	319684	57164	314584
20 X 10.00 - 8	58276	319686		313654
20 X 10.00 - 10	55893	319687		
23 X 9.50 - 12	53655	319690	319689	314370

HYDRO-GEAR HYDROSTATIC TRANSAXLE

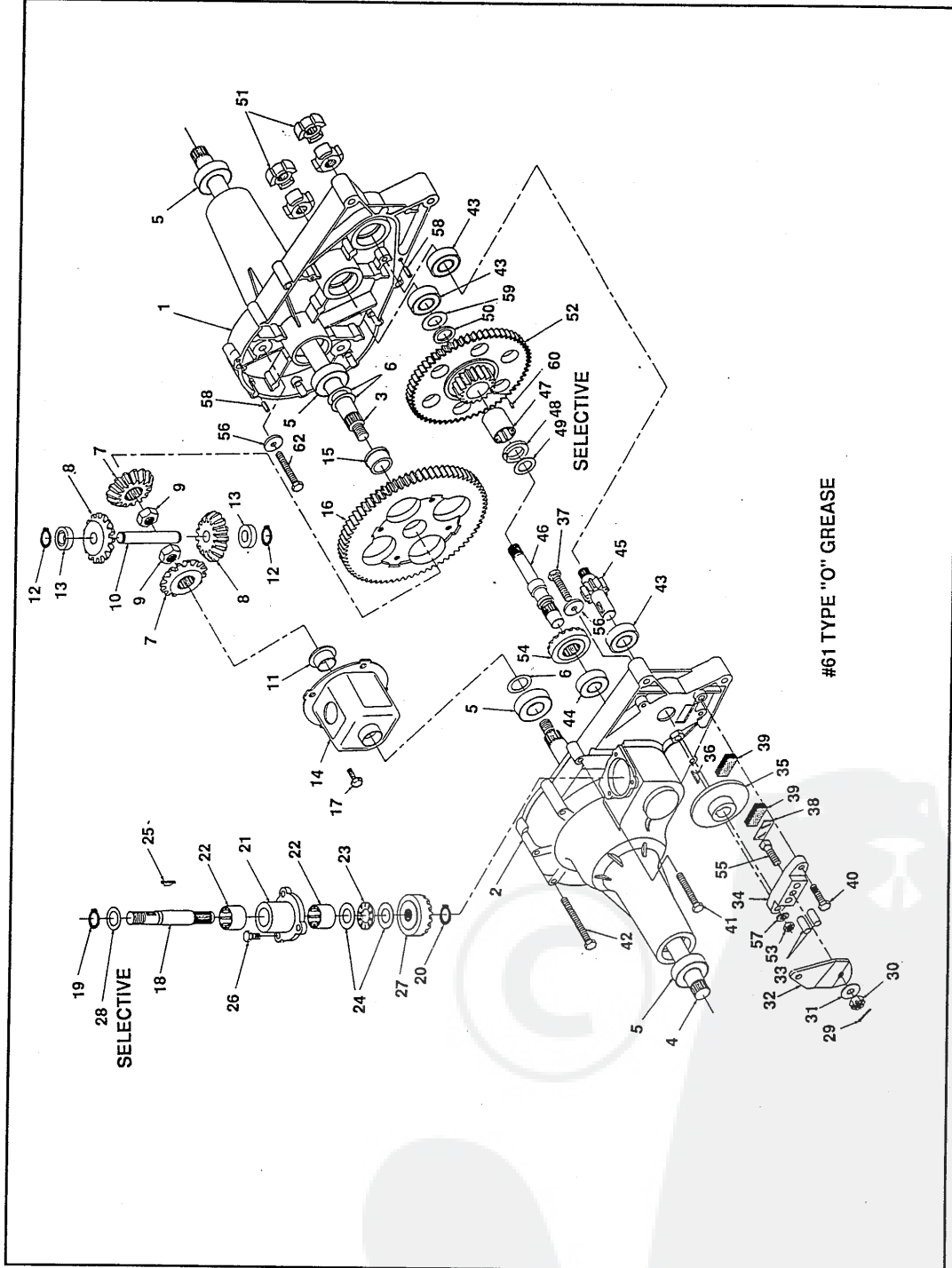

HYDRO-GEAR HYDROSTATIC TRANSAXLE

Ref.	Part No.	Description	Qty.
1	*324090	ASS'Y, HOUSING HALF LH	
	^	HOUSING HALF L.H.	1
5	^	BEARING, BALL 3/4ID X	
		40MM OD X 12 MM	2
43	^	BEARING, BALL	2
	*324092	ASS'Y, HOUSING HALF RH	
2	^	HOUSING HALF RH	1
5	^	BEARING, BALL 3/4ID X	
		40MM OD X 12 MM	2
43	^	BEARING, BALL	1
44	^	BEARING, BALL	1
	*324093	ASS'Y, DIFFERENTIAL/AXLE	
3	^	AXLE L.H. 3/4"	1
4	^	AXLE R.H. 3/4"	1
6	^	WASHER, FLAT 3/4ID X	
		1-1/8OD X .025 THK	3
7	^	GEAR, MITER	2
8	^	GEAR, MITER	2
9	^	NUT, HEX JAM	
		W/PATCH 1/2-20	2
10	^	SHAFT, CROSS	1
11	^	BEARING, FL 3/4 ID X 7/8	
		OD	1
12	^	SNAP RING	2
13	^	BEARING, THRUST	2
14	^	HOUSING	
		DIFFERENTIAL	1
15	^	BEARING, FLANGE	1
16	^	GEAR, DIFFERENTIAL	
		72 TOOTH	1
17	^	LOCKING BOLT,	
		1/4-28 X 9/16" LG	4
	*324095	ASS'Y, INPUT PINION HSG	
18	^	SHAFT, INPUT	1
19	^	SNAP, RING	1
20	^	RING, RETAINING	
		7/16" DIA. EXT.	1
21	^	HOUSING, INPUT BEARING	1
22	^	BEARING, NEEDLE	2
23	^	BEARING, THRUST	1
24	^	WASHER, FLAT 5/8ID X	
		1-1/4OD X .030 THK.	2
25	^	KEY, HI-PRO 3/32 X 5/8 DIA.	1
26	^	SCREW, HEX W/PATCH	
		1/4-20 X 3/4 LONG	3
27	^	GEAR, INPUT PINION	
		17 TOOTH	1
28	^	WASHER, FLAT .62ID X	
		1.0 OD X .050 THK.	1
---	^	WASHER, FLAT .62ID X	
		1.0 OD X .040 THK.	AR

Key No.	Part No.	Description	Qty.
	*324096	ASS'Y, REDUCTION GEAR	
47	^	BEARING, NEEDLE	
48	^	BRONZE THRUST BRG	
		5/8ID X 1-1/4OD X 7/64 THK.	1
49	^	WASHER, FLAT .62ID X	
		1.0 OD X .050 THK.	1
---	^	WASHER, FLAT .62ID X	
		1.0 OD X .040 THK.	AR
50	^	GREASE, SEAL BRONZE	1
52	^	GEAR, 60 AND 17 TOOTH	1
59	^	WASHER, FLAT .62ID X	
		1.0 OD X .030 THK.	1
60	^	PIN, DOWEL	1
25	323688	KEY, HI-PRO 3/32 X 5/8 DIA.	1
29	323671	PIN, COTTER	1
30	323691	NUT, CASTLE 5/16-24	1
31	323684	WASHER, FLAT .343ID X	
		.88OD X .062 THK.	1
32	323665	ARM, BRAKE ACTUATOR	1
33	323681	PIN, BRAKE ACTUATING	2
34	324088	BRAKE, YOKE	1
35	323663	DISC, BRAKE	1
36	323692	KEY, HI-PRO 3/16 X	
		5/8" DIA.	1
37	324092	SCREW, HEX 1/4-20 X	
		1.50 LONG	1
38	323687	PLATE, PUCK	1
39	323685	PUCK, BRAKE	2
40	323711	SCREW, HEX W/PATCH	
		1/4-20 X 1.00 LG	1
41	323677	SCREW, HEX SELF-TAP	
		1/4-20 X 2.00 LG	2
42	323678	SCREW, HEX SELF-TAP	
		1/4-20 X 3.00 LG	4
45	323660	SHAFT, PINION	
		W/11 TOOTH GEAR	1
46	323656	SHAFT, DRIVE	1
51	323661	COUPLING	4
53	323650	NUT, HEX 1/4-20	1
54	323655	GEAR, DRIVE PINION 17 T.	1
55	324088	BOLT, SQUARE HEAD	1
56	323703	WASHER, 15/16OD X	
		.265ID X .125 THK.	1
57	323649	WASHER, 1/4"	
		SPRING LOCK	1
58	323699	PIN, ROLL 3/16" DIA X	
		1/2" LG	2
61	324089	TYPE "O" GREASE	
		(10 OZ. TUBE)	
		(20 OZ. REQ'D)	2

AR = AS REQUIRED
 ^ = THESE SOLD BY ASSEMBLY ONLY.
 * = THIS IS NOT A SERVICEABLE PART.

HYDROSTATIC PUMP

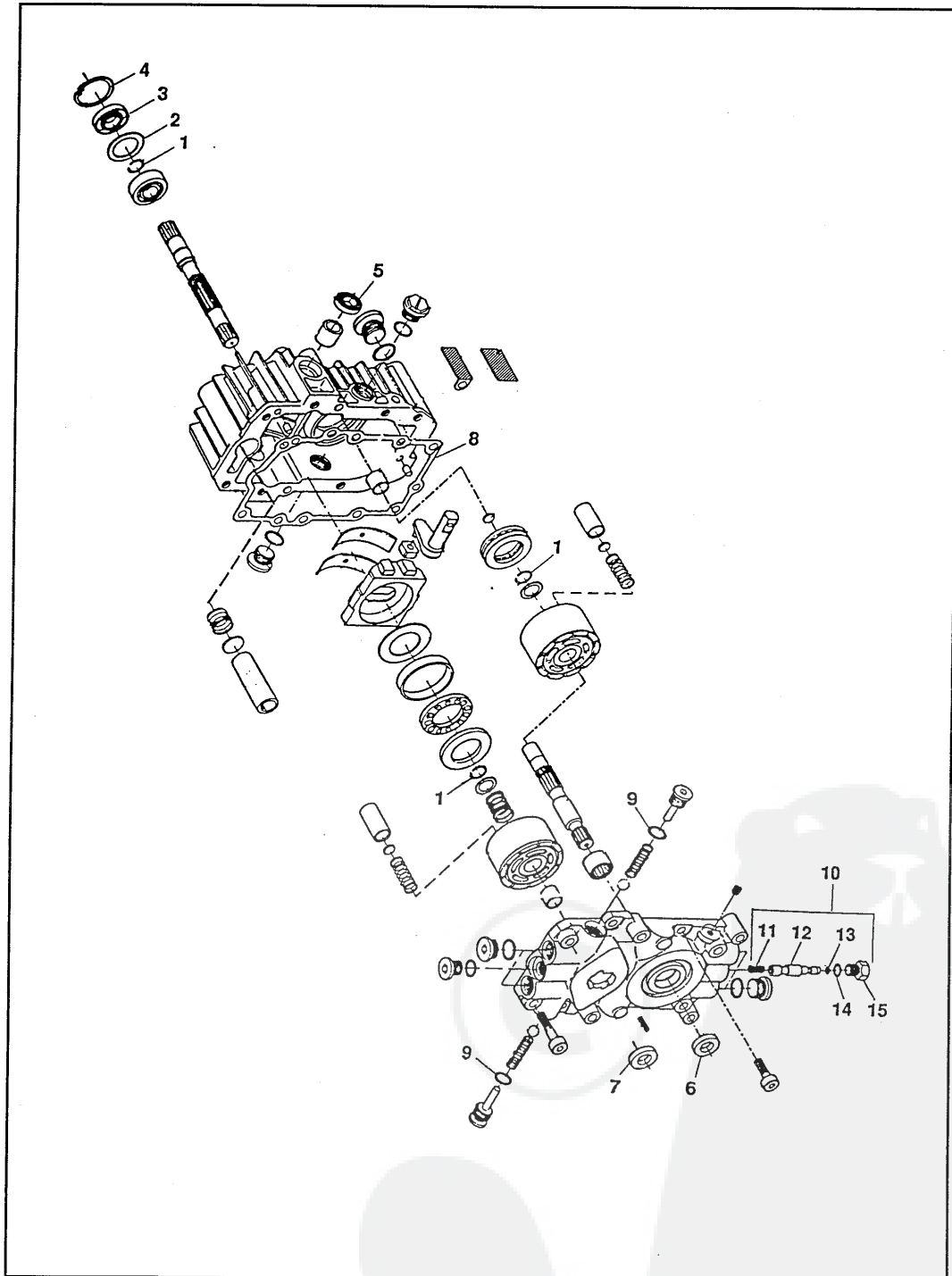

HYDROSTATIC PUMP

Key No.	Part No.	Description
	310227	HYDROSTATIC PUMP (COMPLETE)
	313306	OVERHAUL SEAL KIT (CONTAINS KEY NO.'S 1-9, 13 AND 14)
1		RING-RETAINING
2		SPACER
3		SEAL-LIP
4		RING-RETAINING
5		SEAL-LIP
6		SEAL-LIP
7		SEAL-LIP
8		GASKET-CENTER SECTION
9		O-RING
10	313305	BY-PASS VALVE KIT-COMPLETE (INCL. KEY NO.'S 11-15)
11		SPRING-HELICAL COMP
12		BY-PASS SPOOL
13		O-RING
14		O-RING
15		PLUG-BY-PASS

ACCESSORIES

Contact the dealer where your tractor was purchased for the available accessories. If you are unable to contact the dealer, write to the address on the front cover of this manual.

Rear Engine Rider

Model	Description
5708-16	Bagger - Fits 32" Side Discharge
5708-17	Bagger - Fits 36" Side Discharge
5709-02	Front Weight Box - holds 35 lbs.
5648-16	Lawn Sweeper w/dump Release

Lawn Tractor

Model	Description
5708-22	Bagger - Fits 30" Top Discharge
5708-13	Bagger - Fits 36", 38", 39' & 45" Side Discharge
5708-14	Bagger - Fits 40", 42", 43" & 46" Side Discharge
5661-06	42" Snowblade
5661-08	48" Snowblade
5592-00	Tire Chains - 18" x 6.50"
5585-00	Tire Chains - 18" x 9.50" & 20" x 8"
5672-01	Wheel Weights - Front - 1 pr. w/mtg. hdw. - Fits 15" tires
5673-02	Wheel Weights - Rear - 1 pr. w/mtg. hdw. - Fits 18" & 20" tires
5709-03	Front Weights - Fits 30" & 32" Side Discharge
5648-16	Lawn Sweeper w/dump Release
5705-06	42" Two-Stage Snowblower

Garden Tractor - Light Ground Engaging

Model	Description
5708-13	Bagger - Fits 36", 38", 39", & 45" Side Discharge
5708-14	Bagger - Fits 40", 42", 43" & 46" Side Discharge*
5661-06	42" Snowblade
5672-01	Wheel Weights - Front 1 pr. w/mtg. hdw. - Fits 15" tires
5673-02	Wheel Weights - Rear - 1 pr. w/mtg. hdw. - Fits 18" & 20" tires
5648-16	Lawn Sweeper w/dump Release
5667-02	Sleeve Hitch - w/lift bar
5668-01	Adaptor (sleeve hitch) for use w/23" tires
5706-00	Tire Chains - 20" x 10"
5671-00	Tire Chains - 23" x 9.50"
5672-02	Wheel Weights - Front - 1 pr. w/mtg. hdw. Fits 16" tires
5673-00	Wheel Weights - Rear - 1 pr. w/mtg. hdw. Fits 23" tires
5674-01*	10" One Bottom Moldboard Plow
5675-01*	Cultivator - 7 row - Adj. 6" - 42" width
5676-01*	Disc Harrow - 8" & 11" disc - Adj. width & disc angle
5677-02*	Tiller - 5 H.P. Self-Powered - 28" width
5705-06	42" Two-Stage Snowblower
5661-08	48" Snowblade

Euro Four Wheel Steer

Model	Description
5708-14	Bagger - Fits 40", 42", 43" & 46" Side Discharge
5705-05	42" One-Stage Snowblower
5661-07	48" Snowblade
5709-04	Rear Weight Box
5648-16	Lawn Sweeper w/dump Release
5706-00	Tire Chains 20" x 10"
5671-00	Tire Chains 23" x 9.50"
5672-02	Wheel Weights - Front - 1 pr. w/mtg. hdw. Fits 16" tires
5673-00	Wheel Weights - Rear - 1 pr. w/mtg. hdw. Fits 23" tires
5672-01	Wheel Weights - Front - 1 pr. w/mtg. hdw. Fits 15" tires
5673-02	Wheel Weights - Rear - 1 pr. w/mtg. hdw. Fits 18" & 20" tires

Euro Two Wheel Steer Garden Tractor

Model	Description
5667-04	Sleeve Hitch - w/lift bar Fits 46"
5674-01*	10" One Bottom Moldboard Plow
5675-01*	Cultivator - 7 row - Adj. 6" - 42" width
5676-01*	Disc Harrow 8" & 11" Disc. Adj. width & disc angle
5677-02*	Tiller 5 H.P. Self-Powered - 28" width
5648-16	Lawn Sweeper w/dump Release

*Requires a sleeve hitch