

TRACTEUR - TONDEUSE

MANUEL PIÈCES DE RECHANGE

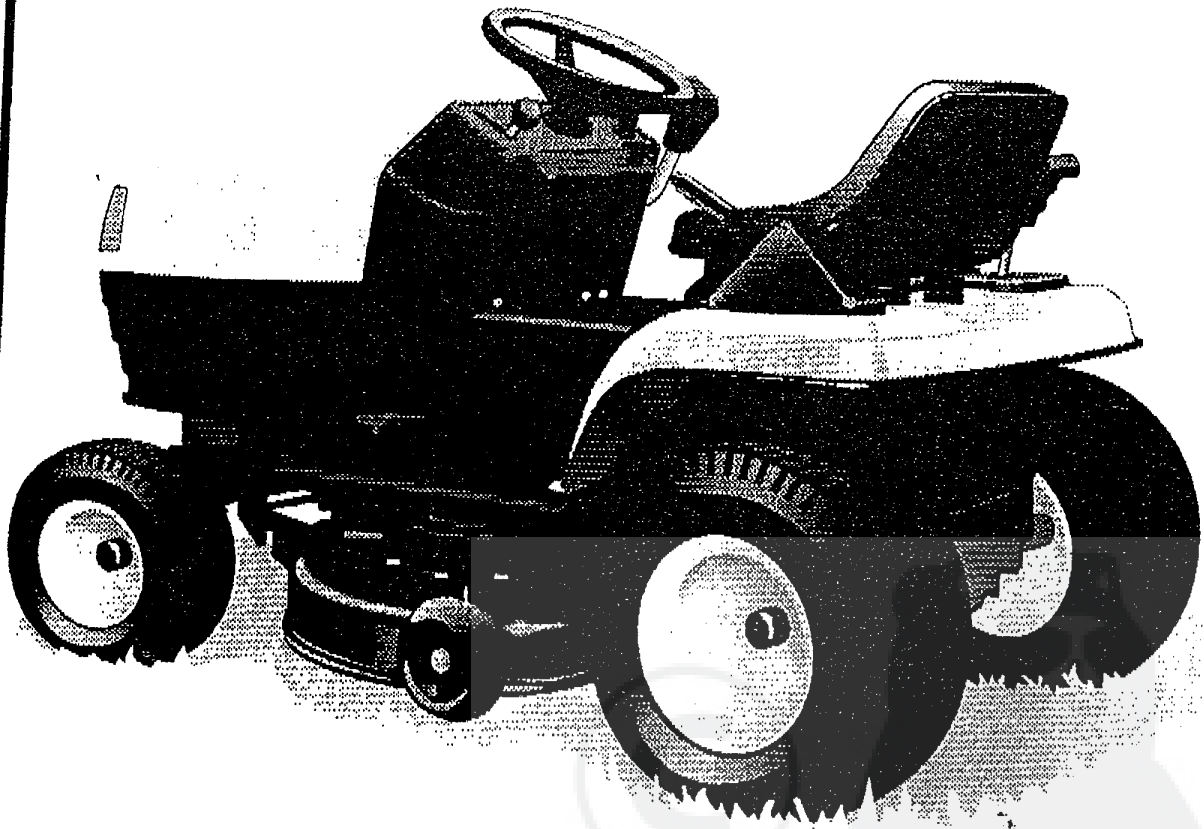

D3554-210

TRACTEUR TONDEUSE 38" MODELE D3554-210

CHASSIS & CAPOT ASSEMBLAGE

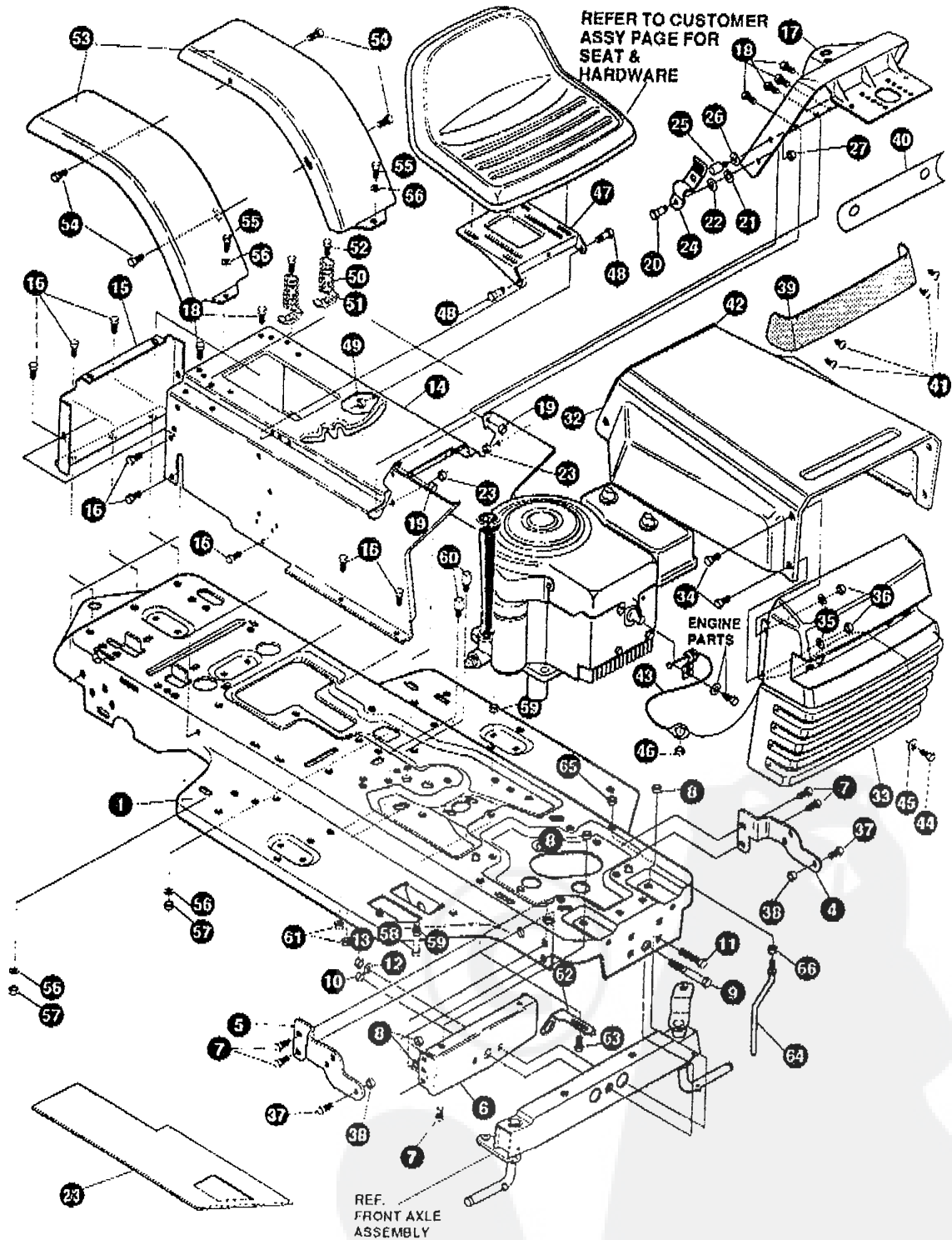

UTILISEZ DES PIÈCES D'ORIGINE POUR CONSERVER L'APPLICATION DE LA GARANTIE.

TOUTES LES PIÈCES NON RÉFÉRÉES SONT INTERCHANGEABLES AVEC LEURS OPPOSÉS.

324796A

TRACTEUR TONDEUSE 38" MODELE D3554-210

KEY#	PART#	DESCRIPTION	QTY.
1	321997-860	FRAME, MAW SF RIDER	1
2	326732	FOOTPAD, LH SF WIDE	1
3	302916	FOOTPAD, RW SF WIDE	1
4	314579-853	BRACKET, GRILLE L.H.	1
5	314578-853	BRACKET, GRILLE R.H.	1
6	56362-853	BRACKET, SUPT FRT AXLE-	1
7	• 328154	SCREW, 5/16-18 X .75WDFLLK	6
8	• 55273	NUT, 5/16-18 HXWDFLLK	6
9	29616	BOLT, .625 X 2.875 SPSH 1/2-20	1
10	• 274654	NUT, 1/2-20 REGHXCTRLK	1
11	• 122201	SCREW, 3/8-16 X 2.75 HHC	2
12	2483	WASHER, .39 ID X 1.25 D X .07 BELLVIL	2
13	• 1499	NUT, 3/8-16 REGHXCTRLK	2
14	314491-860	CONSOLE, SF DYNA STYLE TOPSH	1
15	56235-860	CONSOLE, REAR COVER	1
16	• 995346	SCREW, 1/4-20 X .50 WAHTAP	15
17	320466-860	DASH	1
18	• 995338	SCREW, 1/4-20 X .63 HHWATAP	4
19	50352	NUT 1/4-20 WDFLLK TOP LOCK	2
20	8482	BOLT, .375 X .156 HSH 5/16-18	2
21	• 120394	WASHER, FLAT .406 X .81 X .065	2
22	• 120393	WASHER, FLAT .344 X .69 X .065	2
23	• 1498	NUT, 5/16 18 REGHEXCTRLK	2
24	57159	LATCH, .94 WD X .047 ASSEMBLY HOOD	2
25	53446	PIN, 5/16-18 HOOD LATCH	2
26	• 138538	WASHER, REGINTLK .320 X .61 X .03	2
27	• 45174	NUT, 5/16-18 HEXWDFLLK WHIZ	2
32	314538-860	HOOD	1
33	325401	GRILLE	1
34	• 274672	SCREW, 1/4-20 X .63 WAHHC	4
35	• 120392	WASHER, FLAT .281 X .63 X .065	4
36	• 1502	NUT, 1/4-20 REGHEXCTRLK	4
37	36149	BOLT, .375 X .500 HSH 5/16-18	2
38	• 1498	NUT, 5/16-18 REGHEXCTRLK	2
39	302333	LENS, HEADLAMP	1
40	314948	FOIL, LENS DYNA-PRO REFLECTOR	1
41	• 57796	SCREW, #8 X .50 PLASTITE	4
42	47453	EDGING, WIDE BLK	25
43	311094	LANYARD, HOOD	1
44	121887	SCREW, 1/4-20 X .75 HHC	1
45	120392	FLATWASHER, .281 X .63 X .065	1
46	1502	LOCKNUT, 1/4-20	1
47	58367-853	PLATE, SEAT F-5 SF & LF	1
48	20507	BOLT, .437 X .156 HSH 5/16-18	2
49	• 1498	NUT, 5/16-18 REGHEXCTRLK	2
50	56220	SPRING, 1.43 X 2.38 X .162 COM SEAT	2
51	1341	CLAMP, SPRING 1.17" ID	2
52	• 995346	SCREW, 1/4-20 X .50 WAHTAP	2
53	43970-860	FENDER	2
54	• 995346	SCREW, 1/4-20 X .50 WAHTAP	4
55	• 122017	SCREW, 5/16-18 X 1.00 HHC	2
56	• 446363	WASHER, FLAT .375 X .88 X .082	4
57	• 1498	NUT, 5/16-18 REGHEXCTRLK	2
58	• 427342	SCREW, 3/8-16 X 6.50 HHC	1
59	• 1499	NUT, 5/16-18 REGHEXCTRLK	2
60	• 53446	PIN, 5/16-18	2
61	• 271184	NUT, 5/16-18 HEX KEPS	2
62	302610-853	BRACKET, SWITCH MOUNT	1
63	• 995346	SCREW, 1/4 20 X .50 WAHTAP	1
64	50653	GUIDE, BELT	1
65	• 41529	NUT, 3/8-16 HXCTRLKJAM	1
66	• 271190	NUT, 3/8-16 HEXKEPS	1
	328940	PARTS MANUAL	1
	327383	OPERATOR'S MANUAL (FRENCH)	1

* INDICATES STANDARD HARDWARE ITEMS.

TRACTEUR TONDEUSE 38" MODELE D3554-210

ENSEMBLE SUSPENSION TONDEUSE

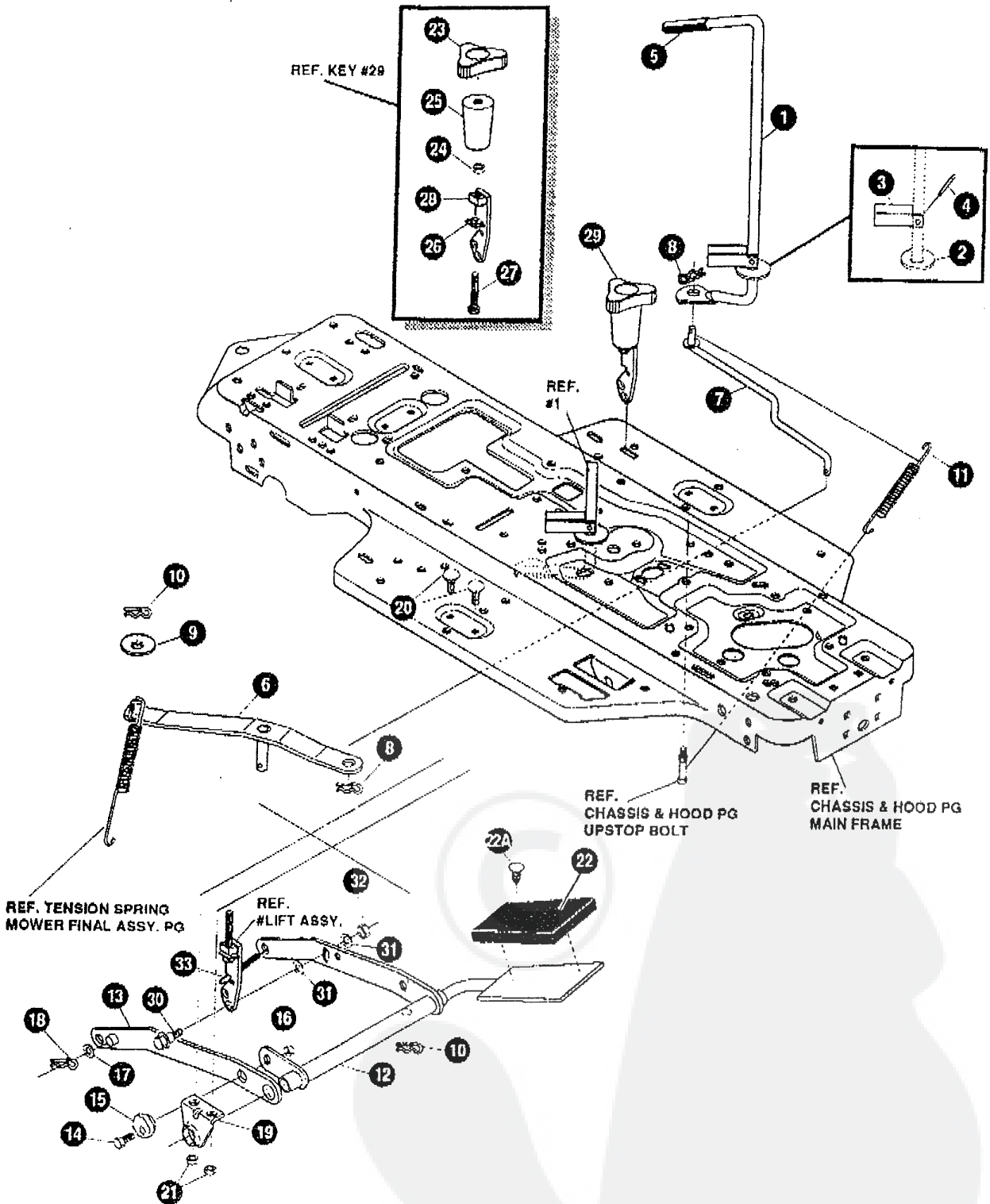

UTILISEZ DES PIÈCES D'ORIGINE POUR CONSERVER L'APPLICATION DE LA GARANTIE.

TOUTES LES PIÈCES NON REFEREES SONT INTERCHANGEABLES AVEC LEURS OPPOSEES.

TRACTEUR TONDEUSE 38" MODELE D3554-210

KEY#	PART#	DESCRIPTION	QTY.
1	325591	HANDLE, RH PTO DASH SF	1
2	22265	WASHER, FLAT .515 X 1.38 X .119 PL	1
3	305225	ML STOP, PTO ENGAGEMENT	1
4	326386	PIN, SPRING. 187 DIA X 1.13LG HD	1
5	46478	GRIP, HAND .50 ID 3.37 LG BLK	1
6	325587	WS STRAP ASSEMBLY, PTO BELCRANK SF	1
7	325590	ROD, BELCRANK LINK	1
8	8260	PIN, HAIR .091 DIA X 1.66 LGZ	2
9	25210	WASHER, FLAT .392 X 1.25 X .09	1
10	8260	PIN, HAIR .091 DIA X 1.66 LGZ	2
11	325802	SPRING, .69 X 7.75 X .0897 TENSION	1
12	326533-853	WP LIFT ASSEMBLY, LH PEDAL-LIFT	1
13	325130-853	WP LIFT ASSEMBLY, RH SF	1
14	180079	• SCREW, 5/16-18 X 1.00 HHC GR5 Z	1
15	58247	• NUT, ADJUST	1
16	1498	• NUT, 5/16-18 REGHEXCTRLK Z	1
17	417098	WASHER, FLAT .531 X 1.06 X .063 Z	2
18	8260	PIN, HAIR .091 DIA X 1.66 LG	2
19	325495-853	MP BRACKET, REAR HANG SUSP	1
20	126211	BOLT, 5/16-18 X .63 CARRIAGE GR2Z	4
21	1498	• NUT, 5/16-18 REGHEXCTRLK	4
22	328596	PAD, LIFT PEDAL	1
22A	309235	FASTENER RATCHET	1
23	325860	KNOB, FLUTED TORQUE BLACK	1
24	45905	• NUT, 3/8-16 HWDFLK MACK Z	1
25	326113	COVER, TOP SLEEVE PEDAL-LIFT	1
26	324983	WASHER, RUBBER 3/8 X .75 SQ	1
27	325832	• BOLT, SUS MOWER LATCH SF	1
28	325831-853	WP LATCH, SUS MOWER SF	1
29	327934	MOWER, ASM LATCH	1
30	25086	• BOLT, .500 X .375 HSSH 5/16-18Z	1
31	4230	WASHER, FLAT .328 X .68 X .104	2
32	1498	• NUT, 5/16-18 HWDFLCTRLK	1
33	35410	SPRING, .071 X .62 X 4.37	1

• INDICATES STANDARD HARDWARE ITEMS

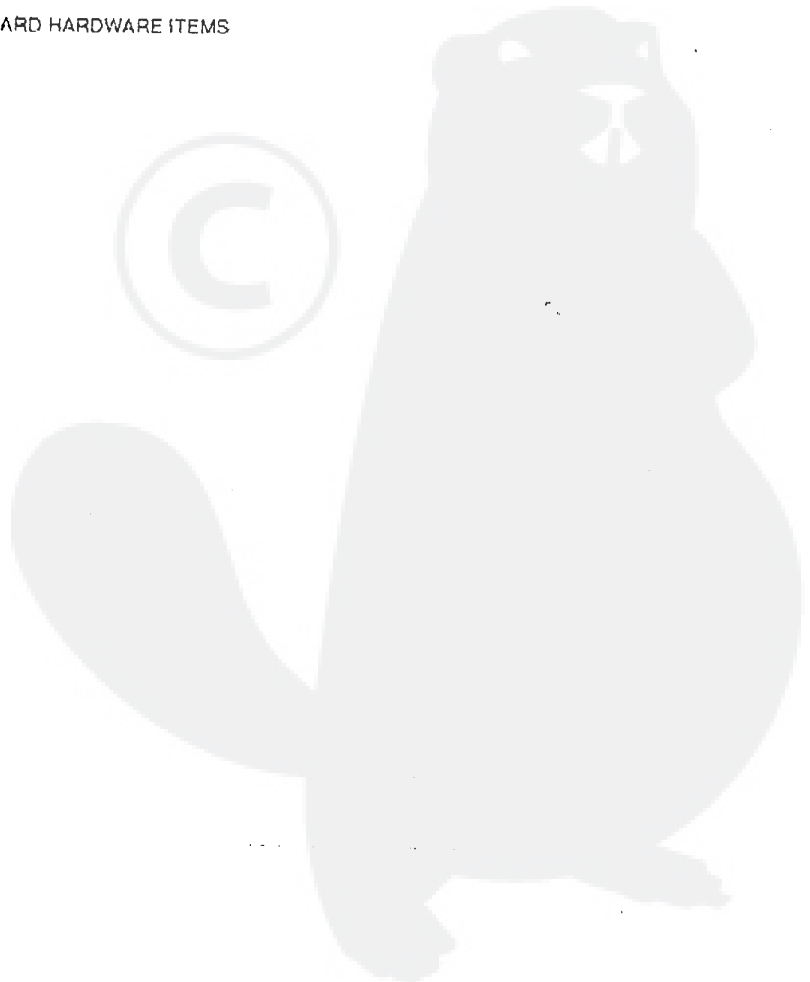
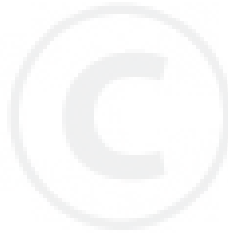

TRACTEUR TONDEUSE 38" MODELE D3554-210

DIRECTION ENSEMBLE

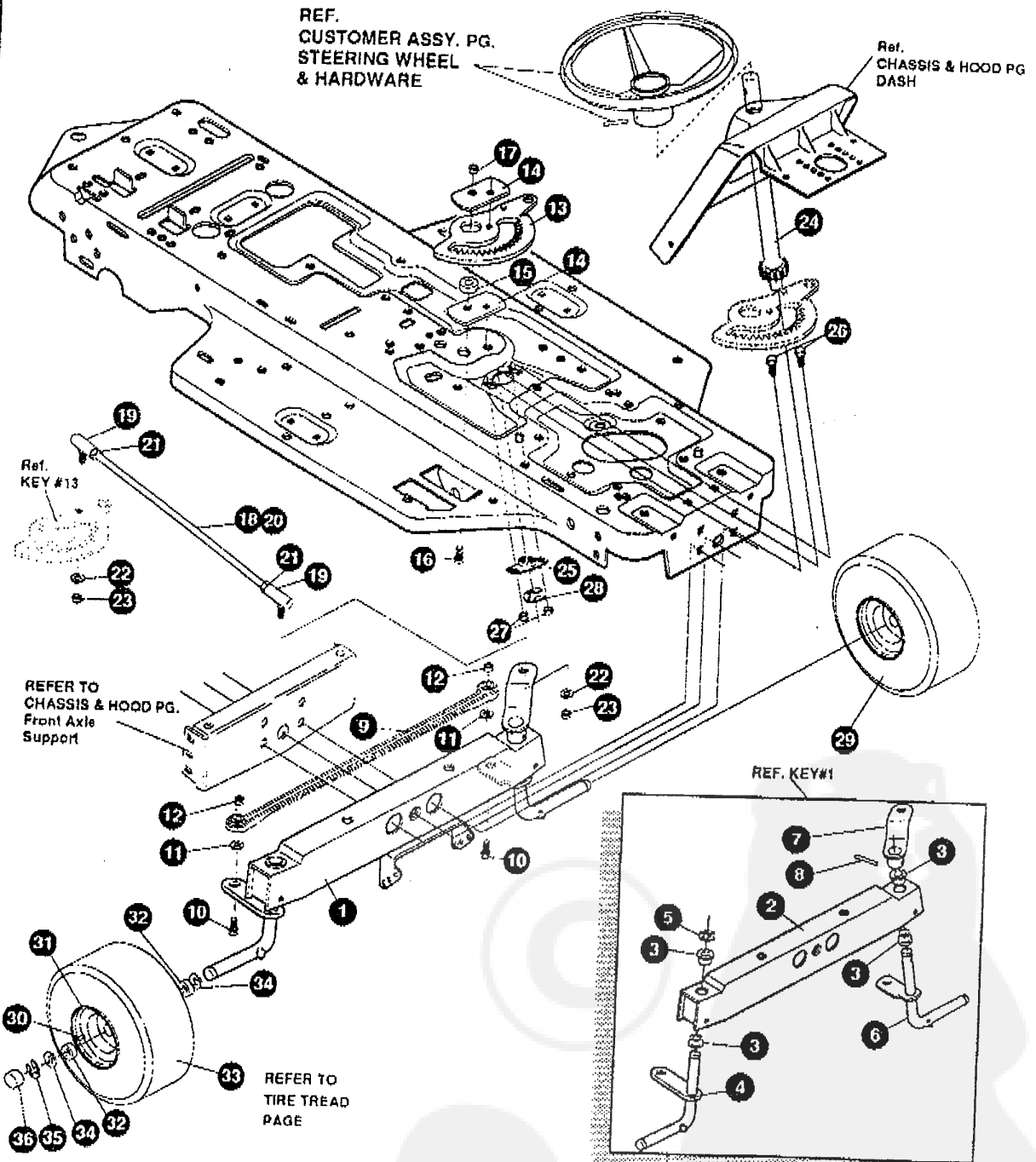

UTILISEZ DES PIECES D'ORIGINE POUR CONSERVER L'APPLICATION DE LA GARANTIE.

TOUTES LES PIECES NON REFEREES SONT INTERCHANGEABLES AVEC LEURS OPPOSEES.

TRACTEUR TONDEUSE 38" MODELE D3554-210

KEY#	PART#	DESCRIPTION	QTY.
1	^	FRONT AXLE ASSEMBLY SF	1
2	324915-853	AXLE, FRONT	1
3	50546	BEARING, FLANGE	4
4	310368	SPINDLE, RH	1
5	36625	RING, RETEX	1
6	310367	SPINDLE, LH	1
7	325223	ARM, STEERING LH	1
8	454565	PIN, SPRING	1
9	302691	TIE ROD	1
10	◇ 122145	SCREW, 3/8-16X1.25 HHC	2
11	◇ 120382	WASHER, .393X.68X.10 REGSPTLK	2
12	◇ 1499	NUT, 3/8-16 REGHCTRLK	2
13	324752	SECTOR, GEAR	1
14	327833	PLATE SECTOR SF	2
15	324753	BUSHING SECTOR GEAR SF	1
16	180124	SCREW, 3/8-16X1.25	1
17	1499	NUT, 3/8-16 REGHXCTRLK	1
18	◇ 328808	DRAGLINK ASSEMBLY	1
19	57158	BALL JOINT	2
20	56190	DRAGLINK	1
21	124925	NUT, 3/8 24 REGHEXJAM	2
22	120382	WASHER, REGSPTLK	2
23	120369	NUT, 3/8-24 REGHEX	2
24	327834	SHAFT PINION STEERING	1
25	325692	BRG. FLANGE	1
26	326505	SCREW, 1/4-20X.75 GRD 5	2
27	46931	NUT, 1/4-20 FLLK NUT SIDE LOCK	2
28	20864	RING RET E	1
29	316702	TIRE, 15X6.0X6	1
30	24167	VALVE STEM	1
31	39829	WHEEL W/BEARING	1
32	314416	BEARING, 1.380DX.753ID FLANGE	2
33	316702	TIRE, 15X6.0X6	1
34	642	WASHER, FLAT .765X1.31X.075	4
35	36625	RING, RETEX .57X.05	2
36	40394	HUB CAP	2

◇ Indicates STANDARD HARDWARE ITEMS.
 ^ ORDER INDIVIDUAL PARTS.

TRACTEUR TONDEUSE 38" MODELE D3554-210

ENTRAÎNEMENT

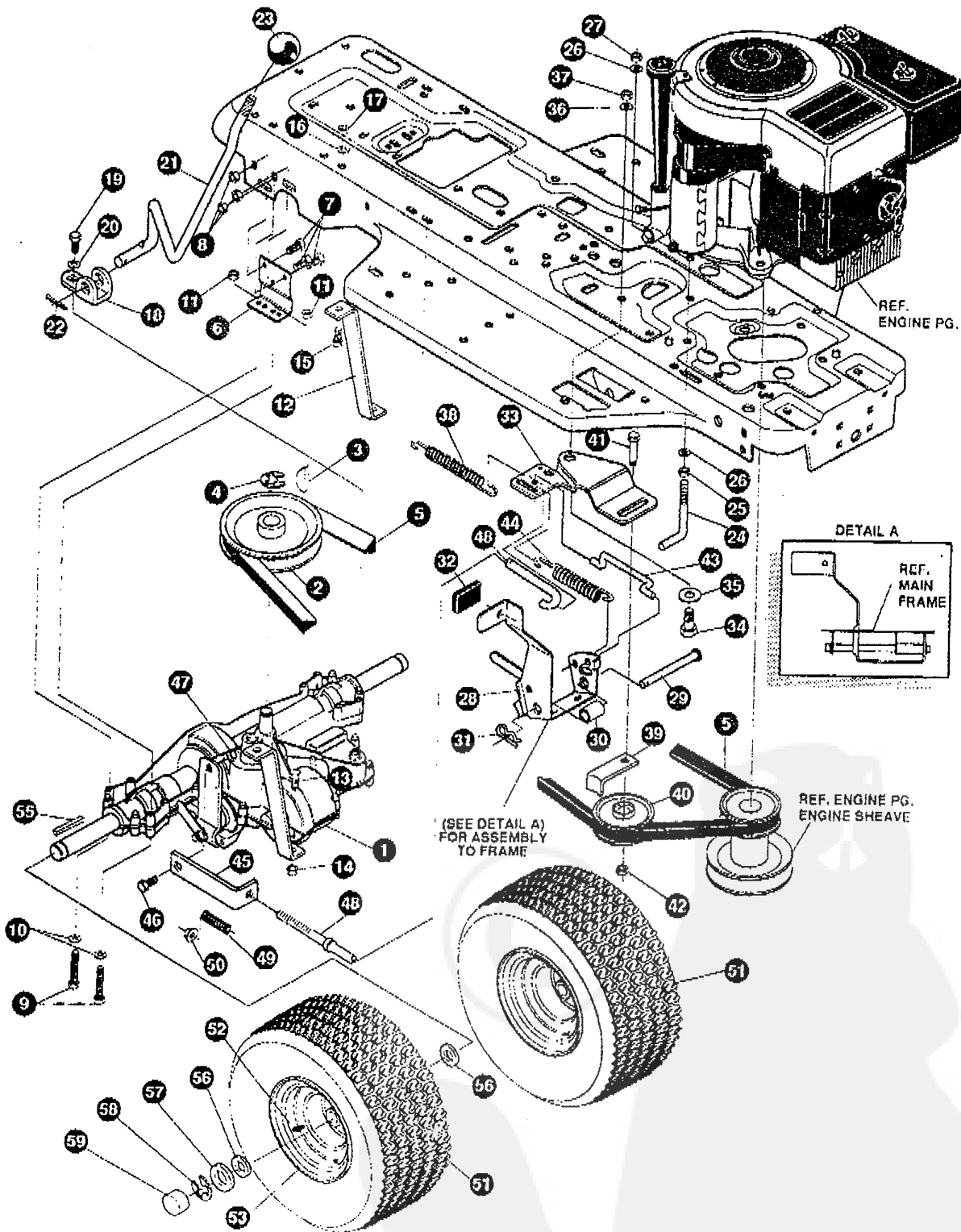

REF. ENGINE PG.

DETAIL A

REF. MAIN FRAME

REF. ENGINE PG. ENGINE SHEAVE

(SEE DETAIL A) FOR ASSEMBLY TO FRAME

UTILISEZ DES PIÈCES D'ORIGINE POUR CONSERVER L'APPLICATION DE LA GARANTIE.

TOUTES LES PIÈCES NON RÉFÉRÉES SONT INTERCHANGÉABLES AVEC LEURS OPPOSÉS.

TRACTEUR TONDEUSE 38" MODELE D3554-210

KEY#	PART#	DESCRIPTION	QTY.
1.	.	TRANSAXLE P940-5SP SF FER	1
2.	302745	PULLEY, IDLER V4L 6.60	1
3.	3021	KEY, WDRF 606 .750X.187X.312	1
4.	22053	RING, RETEX .58X.035TRU5100-62	1
5.	54758	BELT, V 4L 62.00 SF DRIVE	1
6.	53768.853	MP BRACKET, TRANSAXLE	2
7.	120228	SCREW, 5/16-18X .63 HHC	6
8.	1498	NUT, 5/16-18 REGHEXCTRLK	6
9.	180089	SCREW, 5/16-18X2.25 HHC	4
10.	120393	WASHER, FLAT .344X .69X.065	4
11.	1498	NUT, 5/16-18 REGHEXCTRLK	4
12.	313587	MF BRACKET, T/A TORQ. 915 S/F	1
13.	180087	SCREW, 5/16-18X2.00 HHC	1
14.	1498	NUT, 5/16-18 REGHEXCTRLK	1
15.	122017	SCREW, 5/16-18X1.00 HHC	1
16.	138485	WASHER, EXLK .320X.61X.03	1
17.	1498	NUT, 5/16-18 REGHEXCTRLK	1
18.	12616	MH BRACKET, SHIFT P920-3SP	1
19.	56255	SCREW, 1/4-28X .75 NYLHHC	1
20.	57157	WASHER, .750X.250 SP-TRANSAXLE	1
21.	313934	LEVER, SHIFT 915 T/A S/F	1
22.	137185	PIN, COTTER .125 DIA X1.00LG	1
23.	55514-653	KNOB, ROUND 1.50 DIA BLACK	1
24.	49896	MF BELT GUIDE	1
25.	271184	NUT, 5/16-18 HEXKEPS	1
26.	120393	WASHER, FLAT .344X .69X.065	2
27.	1498	NUT, 5/16-18 REGHEXCTRLK	1
28.	302603-853	SF ASSY, BRAKE PEDAL S/F.	1
29.	319676	PIN, CLEVIS .5 DIA. 4.87LG. ZN PL	1
30.	302601	SPACER, SLEV .53 X .62X1.406	1
31.	56180	PIN, HAIR .091 DIA X1.62LG	1
32.	48761	PAD, CLUTCH/BRAKE PEDAL	1
33.	321969	MF IDLER ARM BRKT TRACTION SF	1
34.	41890	BOLT, .625X .218 HSSH 5/16-18Z	1
35.	4107	WASHER, FLAT .635X1.31X.07	1
36.	45602	WASHER, FLAT .333X .87X.119	1
37.	1498	NUT, 5/16-18 REGHEXCTRLK	1
38.	327867	SPRING, 3/4 ODX 6.75X.091 TENSIO	1
39.	39659	MF RETAINER, BELT	1
40.	35374	PULLEY, IDLER V4L 3.06X .62	1
41.	45892	BOLT, 3/8-16X1.50 CARR	1
42.	1499	NUT, 3/8-16 REGHXCTRLK	1
43.	43980	ROD, .268 DIA CLUTCH	1
44.	50562	SPRING, 3/8 ODX 1.625X.055 TENSIO	1
45.	323210	BRACKET, TRACTION BRAKE S/F	1
46.	46824	BOLT, .500X .188 HSSH 5/16-18Z	1
47.	1498	NUT, 5/16-18 REGHEXCTRLK	1
48.	323211	ROD, BRAKE 915 T/A SF	1
49.	53820	SPRING, CLUTCH .625 OD	1
50.	50352	NUT, 1/4-20 WDFLLK TOPLOCK	1
51.	316702	TIRE, PU 20X8.0-8 TURWHI	2
52.	24167	VALVE STEM	1
53.	326362	WHEEL&HUB ASSY 20X8 WHITE	1
55.	52928	KEY, SQUARE .1875OX2.25LG	2
56.	642	WASHER, FLAT .755X1.31X.075	4
57.	42815	WASHER, FLAT .755X1.53X.07	2
58.	36625	RING, RETEX .57X.05TRU5133-75	2
59.	40394	HUB CAP, 1.500ID X 7/8LG	2

TRACTEUR TONDEUSE 38" MODELE D3554-210

MOTEUR ENSEMBLE

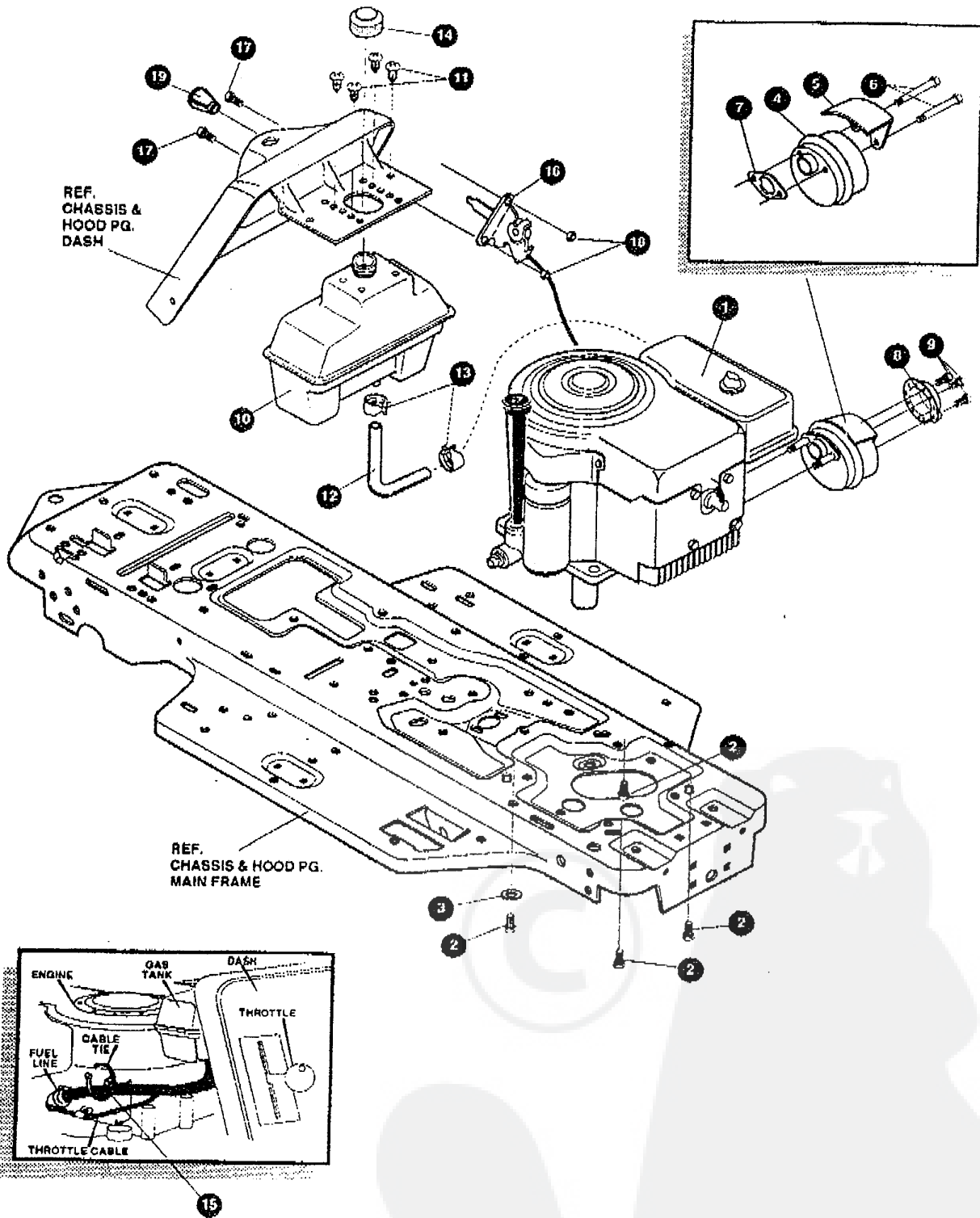

UTILISEZ DES PIECES D'ORIGINE POUR CONSERVER L'APPLICATION DE LA GARANTIE.

TOUTES LES PIECES NON REFEREES SONT INTERCHANGEABLES AVEC LEURS OPPOSEES.

325601A

TRACTEUR TONDEUSE 38" MODELE D3554-210

KEY#	PART#	DESCRIPTION	QTY.
1	ENGINE	ENGINE. 12 HP B&S I/C (SEE ENGINE MANUAL)	1
2	y 50947	SCREW, 3/8-16 X 1.25 WAHTAP	4
3	y 138489	WASHER, EXLK .384 X .69 X .04	1
4	57908	MUFFLER. LO TONE NELSON EXPORT	1
5	54767	SHIELD, HEAT, FOR ROUND MUFFLER	1
6	y 173063	SCREW, 5/16-18 X 3.50 HHC	2
7	46708	GASKET, MUFFLER	1
8	323423	DEFLECTOR, MUFFLER PARTIAL	1
9	35287	SCREW, #8-32 X .38 HHWATAP GR2	3
10	314989	TANK, FUEL 1 GAL	1
11	y 49050	SCREW, 1/4-10 X .75PHNTAP	4
12	47452	GAS LINE, .25 ID	12"
13	48672	CLAMP, FUEL LINE	2
14	46704	GAS CAP, 1-1/2:7 THD	1
15	57444	CABLE TIE	1
16	320031	THROTTLE CONTROL	1
17	y 35291	SCREW, 10-24 X .50 SLHMA	2
18	y 271166	NUT, #10-24 HEXKEPS	2
19	50607	KNOB, ROUND THROTTLE	1

- INDICATES STANDARD HARDWARE ITEMS.

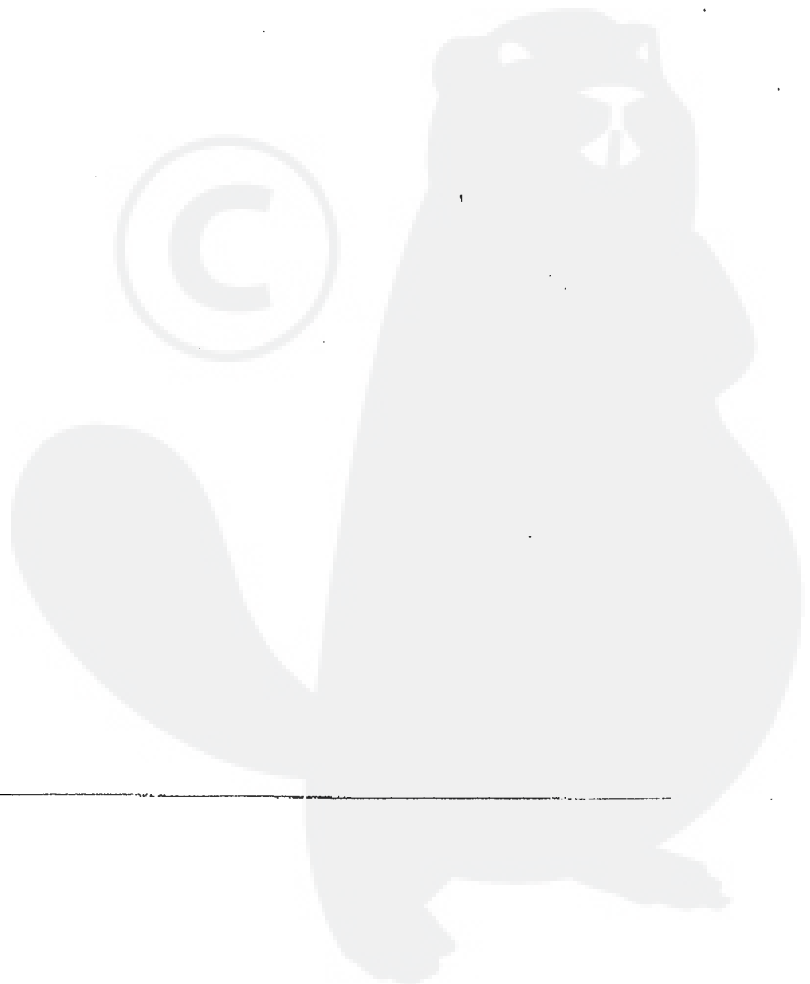

TRACTEUR TONDEUSE 38" MODELE D3554-210

CARTER DE TONDEUSE

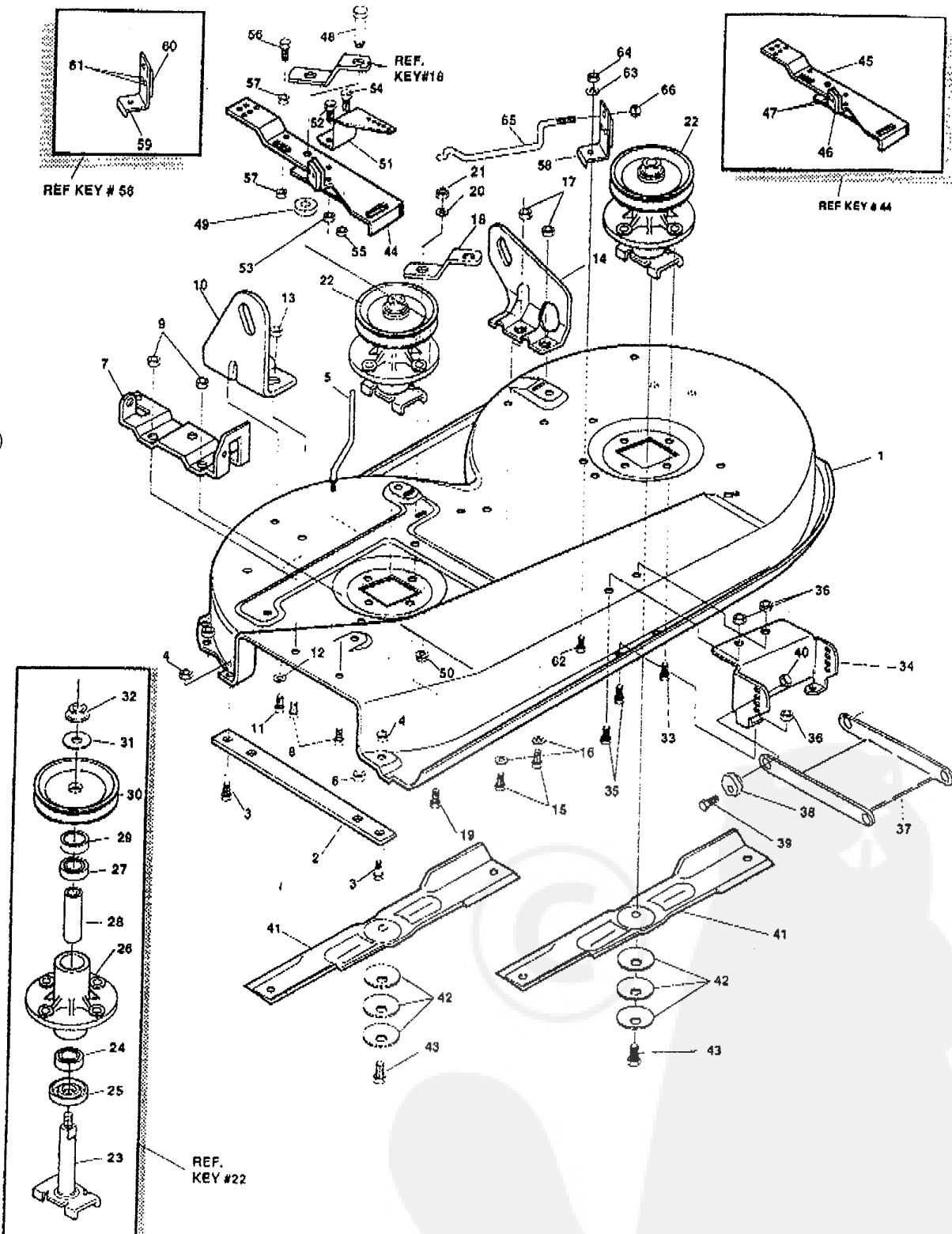

UTILISEZ DES PIECES D'ORIGINE POUR CONSERVER L'APPLICATION DE LA GARANTIE.

TOUTES LES PIECES NON
REFEREES SONT
INTERCHANGEABLES AVEC
LEURS OPPOSEES.

326046B

TRACTEUR TONDEUSE 38" MODELE D3554-210

KEY#	PART#	DESCRIPTION	QTY.
1	315610	DECK, 39"SD MOWER	1
2	326295	BAR, SKID-MULCH	1
3	126216	BOLT, 5/16-18 X .75 CARRIAGE	2
4	01498	NUT, 5/16-18 REGHEXCTRLK	2
5	57318	GUIDE, BELT 5/16-18 THD	1
6	01498	NUT, 5/16-18 REGHEXCTRLK	1
7	57360	BRACKET, CHUTE	1
8	0120834	SCREW, 5/16-18 X .50 HHC	2
9	01498	NUT, 5/16-18 REGHEXCTRLK	2
10	58250	LIFT BRACKET, REAR, RH	1
11	0180077	SCREW, 5/16-18 X .75 HHC	2
12	120393	WASHER, FLAT .344 X .69 X .065	2
13	01498	NUT, 5/16-18 REGHEXCTRLK	2
14	58251	BRACKET, DECK LIFTREAR LH	1
15	0180077	SCREW, 5/16-18 X .75 HHC	2
16	120393	WASHER, FLAT .344 X .69 X .065	2
17	01498	NUT, 5/16-18 REGHEXCTRLK	2
18	315302	BRACKET, IDLER SUPPORT	1
19	0300345	SCREW, 5/16-18 X 1.38 WATAP	1
20	120393	WASHER, FLAT .344 X .69 X .065	1
21	01498	NUT, 5/16-18 REGHEXCTRLK	1
22	56424	QUILL ASSEMBLY, 36/39/40/43	2
23	56425	SHAFT/SADDLE 36"	1
24	49562	BEARING, BALL	1
25	50616	DUST SHIELD	1
26	55547	QUILL CASTING	1
27	49562	BEARING, BALL	1
28	50818	SPACER, 3.797 LG X .669 ID X .88 OD	1
29	51449	SPACER, .438 LG X .932 OD X .672 ID.PM	1
30	56390	PULLEY, 26/36" QUILL	1
31	56365	SPECIAL WASHER	1
32	01282	NUT, 7/16-20 WDFLLK	1
33	050634	SCREW, 5/16-18 X .88 WAHTAP	8
34	58315	LIFT SUPPORT FRONT DECK	1
35	0180075	SCREW, 5/16-18 X .63 HHC	4
36	01498	NUT, 5/16-18 REGHEXCTRLK	4
37	58305	LINK BRACKET, DECK FR	1
38	58247	ADJUSTING NUT	2
39	0122017	SCREW, 5/16-18 X 1.00 HHC	2
40	01498	NUT, 5/16-18 REGHEXCTRLK	2
41	57299	BLADE, 19.69 LO-LIFT	2
42	2483	WASHER, .39 ID X 1.25 D X .07 BELLVIL	6
43	039573	SCREW, 3/8-24 X 1.00 NYLHHC	2
44	320565	IDLER ARM ASSEMBLY	1
45	300490	IDLER ARM	1
46	306973	BRAKE PAD	1
47	41601	RIVET,OVSET 187 DIA X .50 LG ST	2
48	300180	BOLT, .50 X .188 HSH3/8-16	1
49	996416	WASHER, FLAT .391 X 1. — X .125	1
50	45171	NUT, 5/16-18 X .75 HHC WHIZ-LOCK	1
51	326249	BRACKET, EXTENSION IDLER	1
52	180077	SCREW, 5/16-18 X .75 HHC	1
53	1498	NUT, 5/16-18 REGHEXCTRLK	1
54	120854	SCREW, 1/4-20 X .63 HHC-GR2	1
55	1502	NUT, 1/4-20 REGHXCTRLK	1
56	121954	SCREW, 1/4-20 X 2.00 HHC	1
57	271172	NUT, 1/4-20 REGHEXKEPS	2
58	303247	ASSEMBLY BLADE BRAKE	1
59	303246	BRAKE ARM	1
60	306973	BRAKE PAD	1
61	135624	RIVET,TRSET 185 DIA X .41	2
62	180075	SCREW, 5/16-18 X .63 HHC	1
63	120393	WASHER, FLAT .344 X .69 X .65	1
64	1498	NUT, 5/16-18 REGHEXCTRLK	1
65	300316	ROD, BRAKE	1
66	1502	NUT, 1/4-20 REGHEXCTRLK	1

0 INDICATES STANDARD HARDWARE ITEMS

TRACTEUR TONDEUSE 38" MODELE D3554-210

CARTER DE TONDEUSE

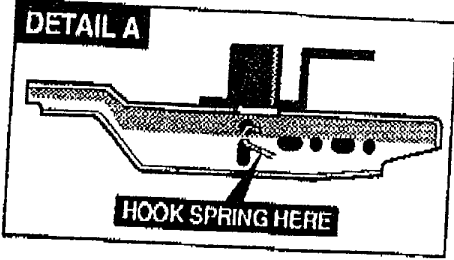

SEE DWG. 326046 FOR PART ASSY OF PAINTED DECK

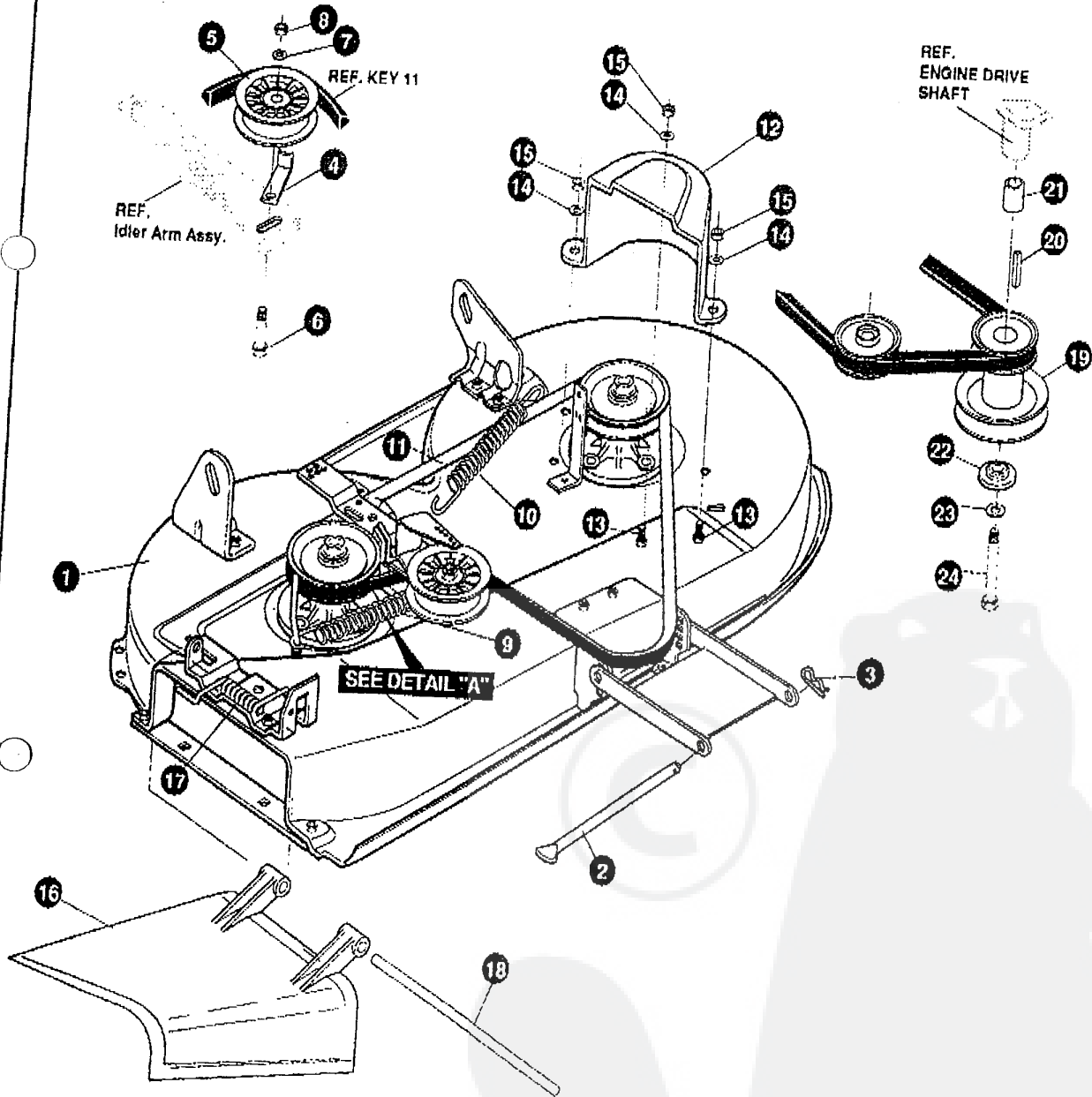

UTILISEZ DES PIECES D'ORIGINE POUR CONSERVER L'APPLICATION DE LA GARANTIE.

TOUTES LES PIECES NON REFEREES SONT INTERCHANGEABLES AVEC LEURS OPPOSEES.

326048B

TRACTEUR TONDEUSE 38" MODELE D3554-210

KEY#	PART#	DESCRIPTION	QTY.
1	*	ASSEMBLY DECK 39SD 2-DECKWH	1
2	58306	ROD, DECK HITCH	1
3	8260	PIN, HAIR .091 DIA X 1.66	1
4	1346	BELT RETAINER, 2.55 OD	1
5	310326	PULLEY, IDLER BFF 4.00	1
6	57325	BOLT, 3/8-16 X 2.00 CARRIAGE	1
7	120382	WASHER, REGSPTLK .393 X .68 X .10	1
8	◊ 120377	NUT, 3/8-16 REGHX	1
9	322064	SPRING, .071 X .62 X 4.37	1
10	326256	SPRING, TENSION	1
11	300680	BELT, V 5L 77.75	1
12	328257	GUARD, BELT LH	1
13	180075	SCREW, 5/16-18 X .63 HHC	3
14	120393	WASHER, FLAT .344 X .69 X .065	3
15	◊ 1498	NUT, 5/16-18 REGHEXCTRLK	3
16	57818	CHUTE-36SD, 39 SD	1
17	314975	SPRING, TORSION	1
18	57317	PIVOT ROD, CHUTE	1
19	310250	PULLEY ENGINE	1
20	303151	KEY SQUARE .249X4.50	1
21	304246	SPACER SLEEVE 1.01 X 1.48	1
22	56431	WASHER .980 X 1.38 X 4.37 PILOT	1
23	120383	WASHER, REGSPTLK .459 X .78 X .12	1
24	433146	SCREW, 7/16-20 X 4.25	1

◊ Indicates STANDARD HARDWARE ITEMS.

* ORDER DECK KIT # 317579 FOR COMPLETE DECK.

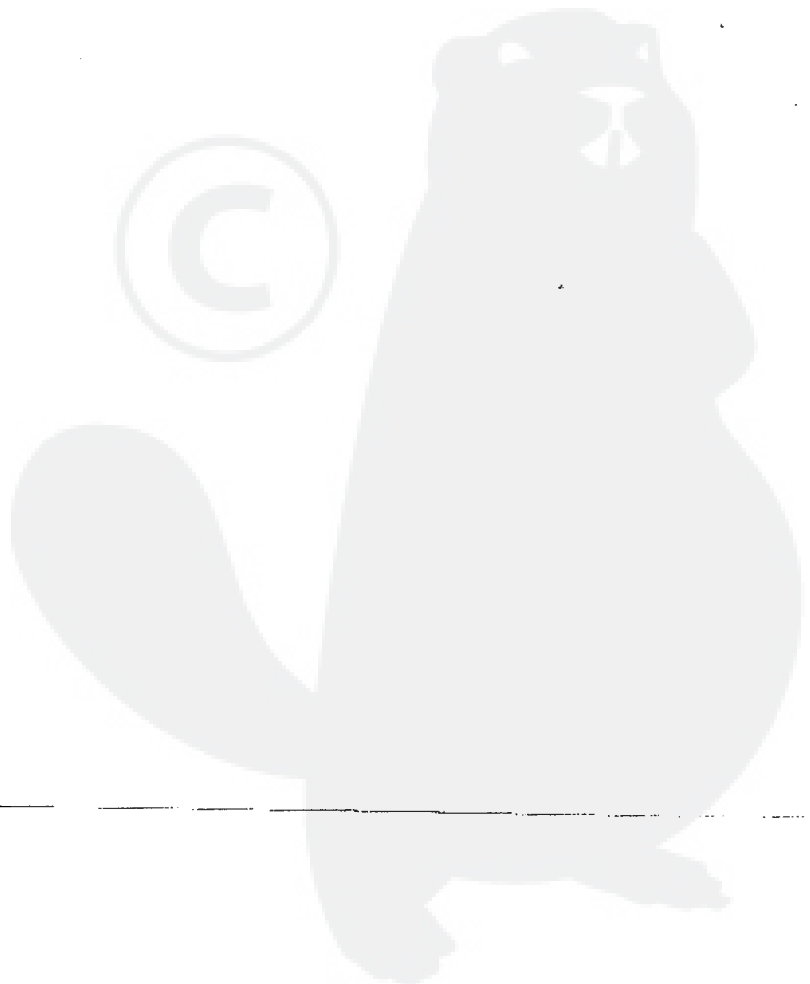
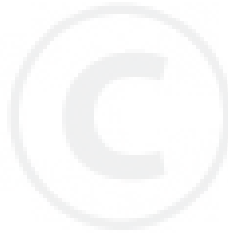

TRACTEUR TONDEUSE 38" MODELE D3554-210

FAISCEAU ELECTRIQUE ENSEMBLE

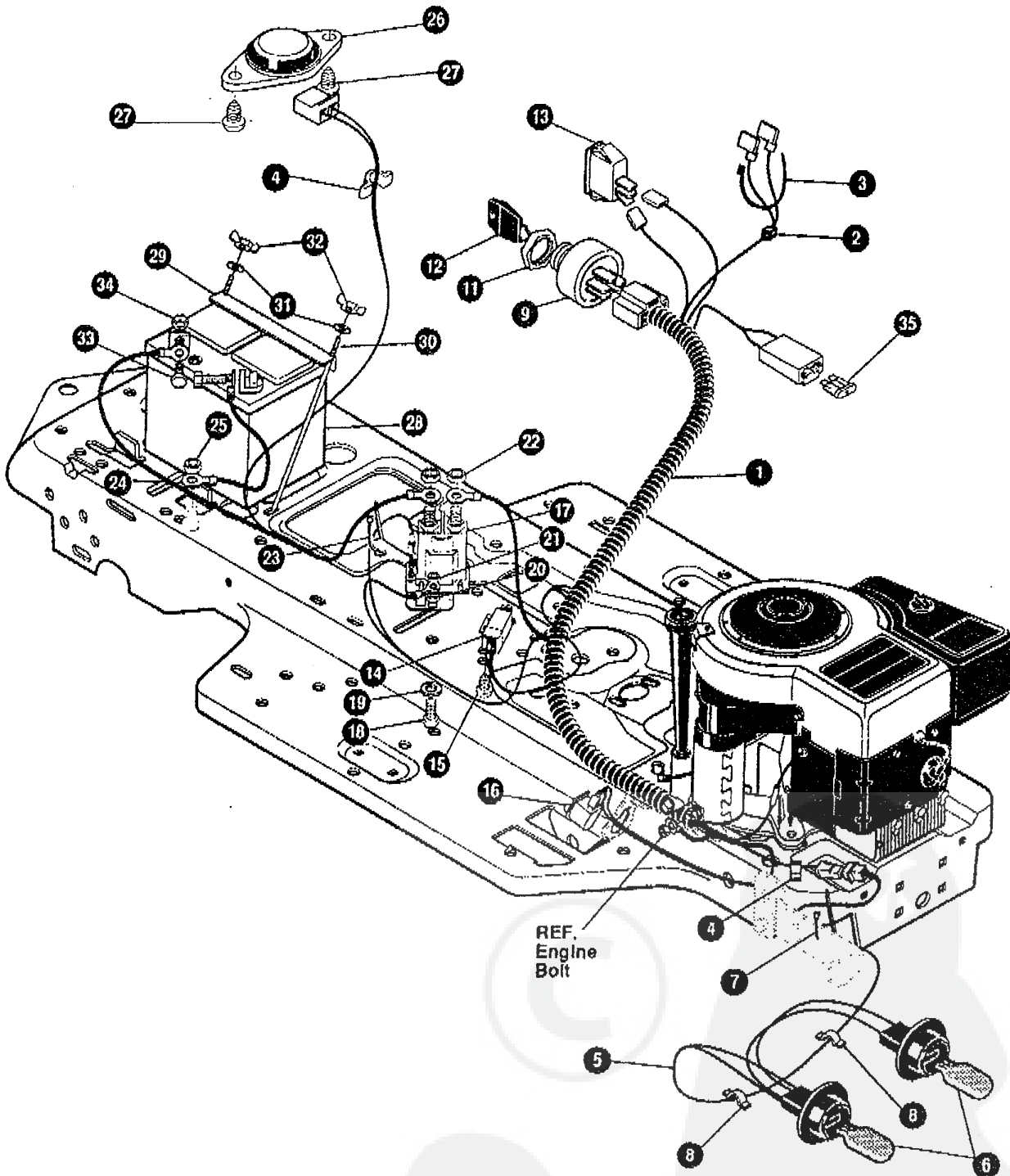

UTILISEZ DES PIÈCES D'ORIGINE POUR CONSERVER L'APPLICATION DE LA GARANTIE.

TOUTES LES PIÈCES NON RÉFÉRÉES SONT INTERCHANGEABLES AVEC LEURS OPPOSÉS.

326872A

TRACTEUR TONDEUSE 38" MODELE D3554-210

KEY#	PART#	DESCRIPTION	QTY.
1.	325084	WIRE HARNESS SF 12 B&S IC W/AMM	1
2.	322298	SPLICER	1
3.	57444	TIE, CABLE	1
4.	41482	PRESS CLIP, 1.380 LG .255 ID	2
5.	303064	ASSEMBLY, LIGHT WIRE-1/4 TURN	1
6.	316823	BULB, HEADLAMP	2
7.	57444	TIE, CABLE BLACK NYLON 5,62 L	1
8.	41482	PRESS CLIP, 1.380 LG .255 ID	2
9.	327355	SWITCH-IGNITION (AFTER FIRE) 3 POSITION	1
11.	327352	NUT, 5/8-8 ACME DELTA	1
12.	327349	KEY, IGNITION SWITCH,STEEL	1
13.	300334	LIGHT SWITCH, ON/OFF PANEL MNT	1
14.	57476	SWITCH, SCREW MOUNT DP NC NO BLACK	1
15.	57220	SCREW, #12 X .50 PHPNHTAP BLACK	2
16.	326653	SWITCH, SNAPMNT NO .055/.116 BLK	1
17.	53716	SOLENOID	1
18.	187745	SCREW, 1/4-20 X .75 HXSEMMA	2
19.	1084	WASHER, FLAT .281 X 1.00 X .063 PL	1
20.	1502	NUT, 1/4-20 REGHEXCTRLK	2
21.	271172	NUT, 1/4-20 REGHEXKEPS	1
22.	271187	NUT, 5/16-24 HKEPS	2
23.	57444	TIE, CABLE BLACK NYLON 5.62L	1
24.	55511	WIRE, GROUND, 12.5"	1
25.	271184	NUT, 5/16-18 HEXKEPS	1
26.	57547	SWITCH, SEAT	1
27.	160505	SCREW, 1/4-20X .38PHPNHMA	2
28.	57486	BATTERY, YUASA 12V 5-PLATE	1
29.	324719	BATTERY BRACKET	1
30.	40234	BATTERY ROD	2
31.	120392	WASHER, FLAT .281X .63X.065	2
32.	325232	WINGNUT, 1/4-20 NYLON	2
33.	120854	SCREW, 1/4-20X .63 HHC	2
34.	271172	NUT, 1/4-20 REGHEXKEPS	2
35.	302031	FUSE, 15 AMP SPADE TYPE	1

- INDICATES STANDARD HARDWARE ITEMS
- ** Spade type fuse included with the wire harness.

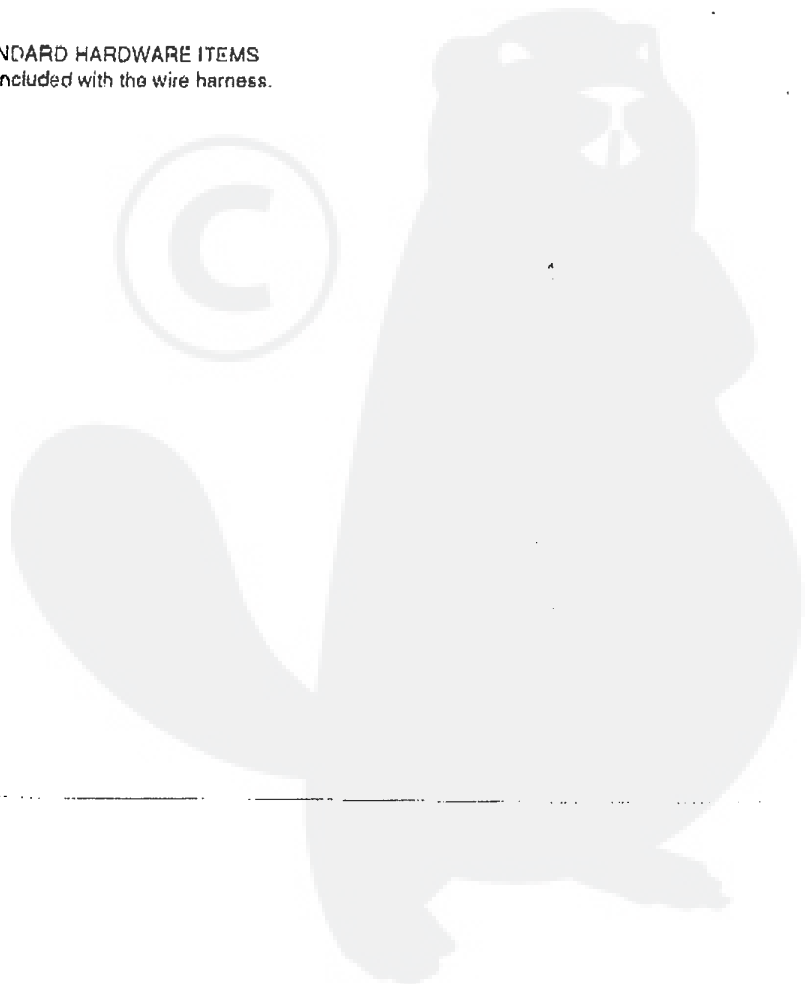
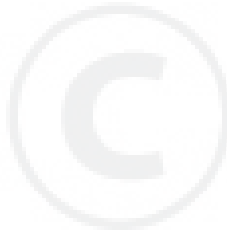

TRACTEUR TONDEUSE 38" MODELE D3554-210

DETAIL SIEGE ET VOLANT

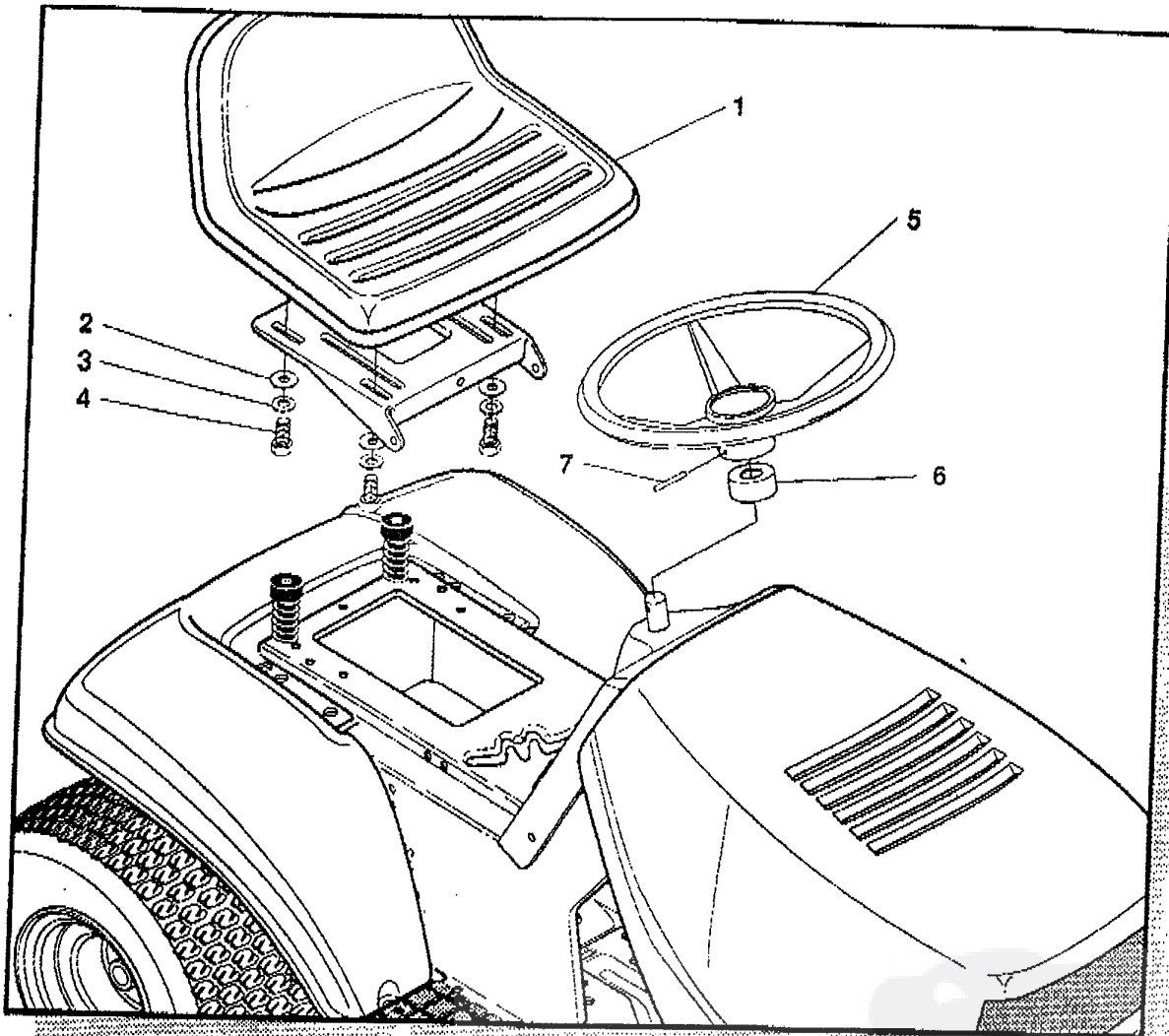

CUSTOMER ASSEMBLY VIEW

315134 PARTS BAG ASSY QTY1

KEY#	PART#	DESCRIPTION	QTY
1	57452	SEAT MV350	1
2	120393	WASHER, FLAT .344X.69X.065	4
3	120638	WASHER, HVSP LTK .328X.60X.109	4
4	122007	SCREW, 5/16-18X.75 HHC	4
5	301251	STEERING WHEEL	1
6	323758	STEERING, SLEEVE	1
7	456378	ROLL PIN .250DIA X 2.0LG	1

ACCESSORIES

Contact the dealer where your tractor was purchased for the available accessories. If you are unable to contact the dealer, write to the address on the front cover of this manual.

Model	Description	Rear Engine Rider
5708-16	Bagger - Fits 32" Side Discharge	
5708-17	Bagger - Fits 36" Side Discharge & 30" Top Discharge	
5709-02	Front Weight Box - holds 35 lbs.	
5648-16	Lawn Sweeper w/dump Release	
5714-00	Mulching Kit - 30" Top Discharge	

Model	Description	Lawn Tractor
5708-22	Bagger - Fits 30" Side Discharge	
5708-13	Bagger - Fits 36", 38", 39" & 45" Side Discharge	
5705-04	36" Two-Stage Snowblower - Fits 36", 38", 39", & 45" Side Discharge	
5661-06	42" Snowblade - Fits 36", 38", 39", & 45"	
5592-00	Tire Chains - 18" x 6.50"	
5585-00	Tire Chains - 18" x 9.50" & 20" x 8"	
5672-01	Wheel Weights - Front - 1 pr. w/mtg. hdw. - Fits 15" tires	
5673-02	Wheel Weights - Rear - 1 pr. w/mtg. hdw. - Fits 18" & 20" tires	
5709-03	Front Weights - Fits 30" & 32" Side Discharge	
5648-16	Lawn Sweeper w/dump Release	
5714-00	Mulching Kit - 30" Top Discharge	

Model	Description	Garden Tractor - Light Ground Engaging
5708-13	Bagger - Fits 36", 38", 39", & 45" Side Discharge	
5705-04	36" Two - Stage Snowblower - Fits 36", 38", 39", & 45"	
5661-06	42" Snowblade - Fits 36", 38", 39", & 45"	
5672-01	Wheel Weights - Front 1 pr. w/mtg. hdw. - Fits 15" tires	
5673-02	Wheel Weights - Rear - 1 pr. w/mtg. hdw. - Fits 18" & 20" tires	
5648-16	Lawn Sweeper w/dump Release	
5667-02	Sleeve Hitch - w/lift bar - Fits 45"	
5668-01	Adaptor (sleeve hitch) for use w/23" tires	
5706-00	Tire Chains - 20" x 10"	
5671-00	Tire Chains - 23" x 9.50"	
5672-02	Wheel Weights - Front - 1 pr. w/mtg. hdw. Fits 16" tires	
5673-00	Wheel Weights - Rear - 1 pr. w/mtg. hdw. Fits 23" tires	
5674-01*	10" One Bottom Moldboard Plow	
5675-01*	Cultivator - 7 row - Adj. 6" - 42" width	
5676-01*	Disc Harrow - 8" & 11" disc - Adj. width & disc angle	
5677-02*	Tiller - 5 H.P. Self-Powered - 28" width	

Model	Description	Four Wheel Steer
5708-14	Bagger - Fits 40" & 46" Side Discharge	
5705-05	42" One-Stage Snowblower - Fits 40" & 46"	
5661-07	48" Snowblade - Fits 40" & 46"	
5709-04	Rear Weight Box for 40" & 46"	
5648-16	Lawn Sweeper w/dump Release	
5706-00	Tire Chains 20" x 10"	
5671-00	Tire Chains 23" x 9.50"	
5672-02	Wheel Weights - Front - 1 pr. w/mtg. hdw. Fits 16" tires	
5673-00	Wheel Weights - Rear - 1 pr. w/mtg. hdw. Fits 23" tires	
5672-01	Wheel Weights - Front - 1 pr. w/mtg. hdw. Fits 15" tires	
5673-02	Wheel Weights - Rear - 1 pr. w/mtg. hdw. Fits 18" & 20" tires	

Model	Description	Two Wheel Steer Garden Tractor
5667-04	Sleeve Hitch - w/lift bar Fits 46"	
5674-01*	10" One Bottom Moldboard Plow	
5675-01*	Cultivator - 7 row - Adj. 6" - 42" width	
5676-01*	Disc Harrow 8" & 11" Disc. Adj. width & disc angle	
5677-02*	Tiller 5 H.P. Self-Powered - 28" width	
5648-16	Lawn Sweeper w/dump Release	

*Requires a sleeve hitch