

REPAIR PARTS MANUAL

40" - 14 H.P. LAWN TRACTOR

MODEL D3560-210

ONE YEAR LIMITED WARRANTY

For one (1) year from date of purchase by the first consumer for residential use (thirty (30) days commercial use), NOMA Outdoor Products Incorporated warrants that it will replace free of charge, including labor, any original part of any NOMA Outdoor Products Incorporated product found to be defective by any authorized Service Dealer or the factory, except the battery which is warranted for ninety (90) days from date of purchase.

This warranty does not cover engine, transmission, transaxle or differential (these items are covered by their manufacturer's own warranty). This warranty does not cover parts that have failed due to normal wear or parts that have failed subject to misuse or abuse. Transportation of the unit or part to and from an authorized Service Dealer or factory is the responsibility of the owner.

A step by step explanation as to what procedure should be followed for this warranty is:

1. If a part becomes defective, contact the store where the unit was purchased for the name and address of the authorized Service Dealer nearest to you.
2. If you cannot locate an authorized Service Dealer, write Service Department of NOMA Outdoor Products Incorporated for the name and address of the authorized Service Dealer in your area or call the Service Department at 1-901-422-1690.
3. Return the defective product, along with proof of purchase to such authorized Service Dealer for replacement of any defective part where covered by this warranty.

There is no other express warranty. Implied warranties, including those of merchantability and fitness for a particular purpose are limited to one (1) year from date of purchase. Liability for incidental or consequential damages are excluded.

Some states do not allow limitations on how long an implied warranty lasts, so the above limitation may not apply to you. Some states do not allow the exclusion of incidental or consequential damages, so the above exclusion may not apply to you. This warranty gives you specific legal rights, and you may have other rights which vary from state to state.

NOMA Outdoor Products Incorporated

Callers 8000

Jackson, TN 38308-8000

UNIT PARTS AND SERVICE

Fill in and mail the registration card packed with the unit. For service other than covered in this manual, contact an authorized service dealer. A nationwide parts and service organization has been established to provide locally available parts and service. A list of authorized parts distributors has been included in this manual. When ordering repair parts, always give the following information: 1. The Part Name; 2. The Part Number; 3. The Quantity desired; 4. The Full (eight digit) Model Number of the unit. The model number will be found on a plate attached to the unit.



Look for this symbol.  It means - ATTENTION! BECOME ALERT! A HAZARD TO OPERATOR, BYSTANDER, PROPERTY OR EQUIPMENT MAY EXIST.

NOMA Outdoor Products Incorporated
Callers 8000

Part No. 329758A

3-8000

5/83

**SAFETY RULES****THESE INSTRUCTIONS ARE FOR YOUR PROTECTION. PLEASE READ THEM CAREFULLY.****IMPORTANT****THIS CUTTING MACHINE IS CAPABLE OF AMPUTATING HANDS AND FEET AND THROWING OBJECTS. FAILURE TO OBSERVE THE FOLLOWING SAFETY INSTRUCTIONS COULD RESULT IN SERIOUS INJURY OR DEATH.****I. GENERAL OPERATION:**

- Know controls and how to stop quickly.
- Read, understand, and follow all instructions in the manual and on the machine before starting.
- Only allow responsible adults, who are familiar with instructions, to operate the machine.
- Wear safety glasses or eye shields when assembling or operating the machine.
- Do not operate machine when barefooted. Always wear substantial footwear, preferably steel-toed shoes.
- Do not wear loose fitting clothing that could get caught in moving parts.
- Clear the area of objects such as rocks, toys, wires, etc., which could be picked up and thrown by the blade(s).
- Be sure the area is clear of other people before mowing. Stop machine if anyone enters the area.
- Never carry passengers.
- Do not mow in reverse unless absolutely necessary. Always look down and behind before and while backing.
- Be aware of the mower discharge direction and do not point it at anyone. Do not operate the mower without either the entire grass catcher or the guard in place.
- Slow down before turning.
- Never leave a running machine unattended. Always turn off blades, set parking brake, stop engine, and remove keys before dismounting.
- Turn off blade(s) when not mowing.
- Stop engine before removing grass catcher or unclogging chute.
- Mow only in daylight or good artificial light.
- Do not operate the machine while under the influence of alcohol or drugs.
- Watch for traffic when operating near or crossing roadways.
- Use care when mowing around a fixed object to prevent the blade(s) from striking it. Never deliberately run over any foreign object.
- Use extra care when loading or unloading the machine into a trailer or truck.
- Use care when pulling loads or using heavy equipment.
 - a. Use only approved drawbar hitch points.
 - b. Limit loads to those that you can safely control.
 - c. Do not turn sharply. Use care when backing.
 - d. Use counterweight(s), wheel weight or tire chains when suggested in attachment(s) instructions.

II. SLOPE OPERATION:

Slopes are a major factor related to loss-of-control and tip-over accidents, which can result in severe injury or death. All slopes require extra caution. If you cannot back up the slope or if you feel uneasy on it, do not mow it.

DO

- Mow up and down slopes, not across.
- Remove obstacles such as rocks, tree limbs, etc.
- Watch for holes, ruts, or bumps. Uneven terrain could overturn the machine. Tall grass can hide obstacles.
- Use slow speed. Choose a low gear so that you will not have to stop or shift while on the slope.
- Follow the manufacturer's recommendations for wheel weights or counterweights to improve stability.
- Use extra care with grass catchers or other attachments. These can change the stability of the machine.
- Keep all movement on the slopes slow and gradual. Do not make sudden changes in speed or direction.
- Avoid starting or stopping on a slope. If tires lose traction, turn off the blade(s) and proceed slowly straight down the slope.

DO NOT

- Do not turn on slopes unless necessary, and then slowly and gradually downhill, if possible.
- Do not mow near drop-offs, ditches or embankments. The

mower could suddenly turn over if a wheel is over the edge of a cliff or ditch, or if an edge caves in.

- Do not mow on wet grass. Reduced traction could cause sliding.
- Do not try to stabilize the machine by putting your foot on the ground.
- Do not use grass catcher on steep slopes.

III. CHILDREN:

Tragic accidents can occur if the operator is not alert to the presence of children. Children are often attracted to the machine and the mowing activity. Never assume that children will remain where you last saw them.

- Keep children out of the mowing area and under the watchful care of another responsible adult.
- Be alert and turn machine off if children enter the area.
- Before and when backing, look behind and down for small children.
- Never carry children. They may fall off and be seriously injured or interfere with safe machine operation.
- Never allow children to operate the machine.
- Use extra care when approaching blind corners, shrubs, trees, or other objects that may obscure vision.

IV. SERVICE:

- Use extra care in handling gasoline and other fuels. They are flammable and vapors are explosive.
 - a. Use only an approved container.
 - b. Never remove gas cap or add fuel with the engine running. Allow engine to cool before refueling. Do not smoke.
 - c. Never refuel the machine indoors.
 - d. Never store the machine or fuel container inside where there is an open flame, such as in a water heater.
- Check fuel supply before each use allowing space for expansion as the heat of the engine and/or sun can cause gasoline to expand and overflow the tank.
- Use extra care when handling battery acid. Acid contact with skin may cause severe burns. Eye contact may cause blindness.
- Use extra care when servicing the battery. Explosive gas is produced in the battery. Do not service the battery while smoking or near an open spark or flame. This may cause the battery to explode causing serious injury.
- Never run a machine inside a closed area. Exhaust fumes contain CARBON MONOXIDE, an ODORLESS and DEADLY GAS.
- Keep nuts and bolts, especially blade attachment bolts, tight and keep equipment in good condition.
- Never tamper with safety devices. Check their operation regularly.
- Do not change the engine governor settings or overspeed engine.
- Reduce fire hazards. Keep machine free of grass, leaves, or other debris build-up. Clean up oil or fuel spillage. Allow machine to cool before storing.
- Stop and inspect the equipment if you strike an object. Repair, if necessary, before restarting.
- Never make adjustments or repairs with the engine running.
- Grass catcher components are subject to wear, damage, and deterioration, which could expose moving parts or allow objects to be thrown. Frequently check components and replace with manufacturer's recommended parts, when necessary.
- Mower blade(s) are sharp and can cut. Wrap the blade(s) or wear gloves, and use extra caution when servicing them.
- Check brake operation frequently. Adjust and service as required.

**LOOK FOR THIS SYMBOL TO POINT OUT IMPORTANT SAFETY PRECAUTIONS. IT MEANS-- ATTENTION!!! BECOME ALERT!!! YOUR SAFETY IS INVOLVED.**

OWNER'S INFORMATION

Record the following information about your unit so that you will be able to provide it in case of loss or theft.

MODEL NUMBER: - (Enter complete 8 digit number from model plate on unit)

PURCHASE DATE: ___ / ___ / ___ CODE NO.: _____ SERIAL NO.: _____

DEALER'S NAME AND ADDRESS: _____

CITY: _____ STATE: _____ TELEPHONE: _____

CONTENTS OF SHIPPING CARTON

- 1 - Lawn Tractor with 40 inch Mower Deck
- 1 - Operator's Manual
- 1 - Repair Parts Manual
- 1 - Engine Manual
- 1 - Steering Wheel
- 1 - Seat
- 1 - Bag of Assembly Parts Containing:
 - 4 - 5/16 x 3/4 inch Hex Head Screws
 - 4 - 5/16 inch Split Lockwashers
 - 4 - 11/32 inch Flatwashers
 - 1 - Pin, Spring
 - 1 - Spacer, Steering Shaft
 - 2 - Hub Caps
 - 2 - Ring, Retex
 - 4 - Washers, Flat .755 x 1.31 x .075
 - 2 - Tire & Rims, 15 x 6-6
 - 1 - Nut, Push-On Cap
 - 1 - Pivot Rod
 - 1 - Spring, Torsion
 - 1 - Chute Deflector
 - 2 - Nuts, 3/8-16
 - 2 - Bolts, .500 x .390
 - 2 - Gauge Wheels

TOOLS REQUIRED FOR ASSEMBLY

- 2 - 7/16 inch Wrenches (or adjustable wrench)
- 1 - 1/2 inch Wrench (or adjustable wrench)
- 1 - Small Phillips Screwdriver with a 1/4 inch shank
- 1 - Hammer

HOW TO MEASURE SCREW SIZE (5/16 x 1 1/4 INCH)

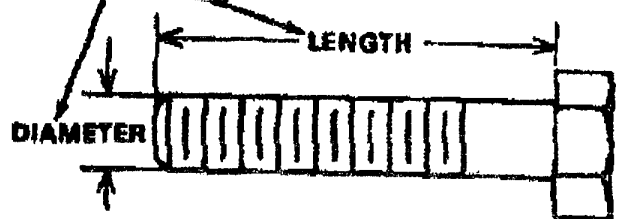

DANGER



This lawn tractor can be dangerous if carelessly used.

Read your Operator's Manual thoroughly before operating your lawn tractor.

Always wear safety glasses or eye shields while assembling or operating your lawn tractor.

DO NOT carry passengers at any time.

Keep your hands, feet, hair and loose clothing away from the discharge area, the underside of the mower deck or any moving parts while the engine is running.

DO NOT allow children or young teenagers to operate or be near your lawn tractor while it is operating.

ALWAYS GIVE THE FOLLOWING INFORMATION WHEN ORDERING REPAIR PARTS:
1. The PART NUMBER; 2. The PART NAME; 3. QUANTITY DESIRED; 4. The MODEL NUMBER (As shown on Model Plate).

SEND PART ORDERS AS PER INSTRUCTIONS ON THE FRONT PAGE.
DO NOT USE KEY NUMBERS WHEN ORDERING REPAIR PARTS, ALWAYS USE PART NUMBERS.

All replacement parts will be supplied in current production colors or in a neutral color.
A handling fee is applicable to small parts orders.

YOUR UNIT IS RIGHT HAND (RH) OR LEFT HAND (LH) AS YOU STAND BEHIND IT.

40" LAWN TRACTOR MODEL D3560-210

CHASSIS & HOOD ASSEMBLY (FRONT)

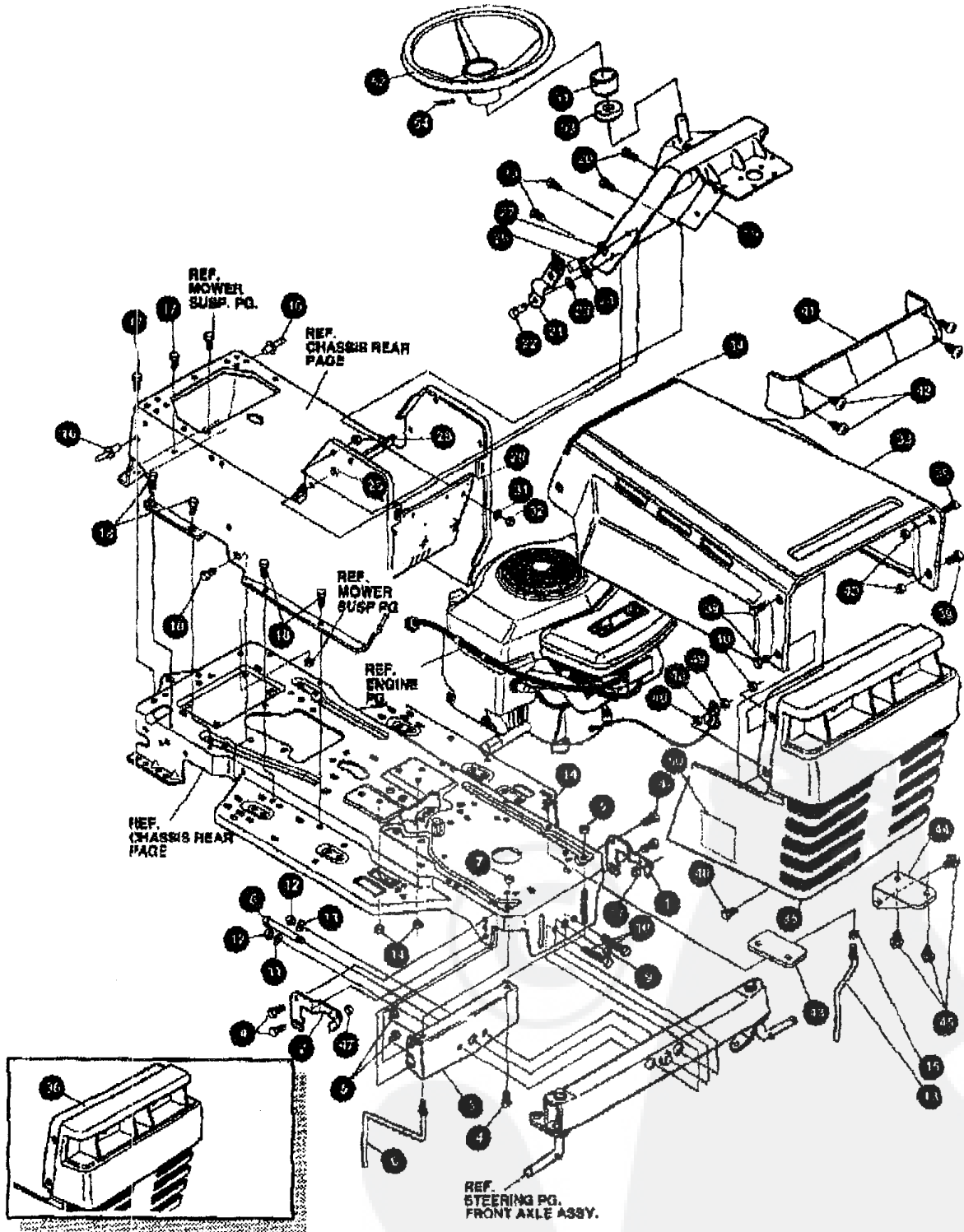

NOTE: ALWAYS USE ORIGINAL EQUIPMENT PARTS. Use of service/replacement parts other than original equipment parts may void your warranty.

ALL UNNUMBERED ITEMS ARE INTERCHANGEABLE WITH OPPOSITE SIDE

328205B

40" LAWN TRACTOR MODEL D3560-210

KEY#	PART#	DESCRIPTION	QTY.
1	58089-853	BRKT.GRILLE, L.H.	1
2	58088-853	BRKT GRILLE R.H.	1
3	313541-853	BRACKET, FRONT AXLE	1
4	56030	SCREW, 5/16-18X.75WDFLLK	1
5	55273	NUT, 5/16-18 HXWDFLLK	5
6	300440	GUIDE, BELT, RIDER	5
7	1498	NUT, 5/16-18 REGHEXCTRLK	1
8	308207	BOLT, .625X2.180 HHSX 1/2-13NC	1
9	309008	NUT, 1/2-13 REGHCTRLK	1
10	122207	SCREW, 3/8-16X3.00 HHC	1
11	2483	WASHER, .391DX1.25DX.07 BELLVIL	2
12	1499	NUT, 3/8-16 REGHXCTRLK	2
13	300635	GUIDE,BELT SHORT 15" WHEEL	1
14	124824	NUT, 5/16-18 HEXJAM	1
15	271190	NUT, 3/8-16 HEXKEPS	1
16	48763	RIVET, POP .187DIA X .450LG ST	3
17	35487	SCREW, 5/16-18X .50 WAHHTAP	2
18	995346	SCREW, 1/4-20X .50 WAHHTAP	10
19	309447-860	DASH	1
20	995346	SCREW, 1/4-20X .50 WAHHTAP	1
21	57159	LATCH, .84WDX.047 ASSY HOOD	2
22	8482	BOLT, .375X .156 HHSX 5/16-18	2
23	120394	WASHER, FLAT .408X .81X.065	2
24	120393	WASHER, FLAT .344X .89X.065	2
25	1498	NUT, 5/16-18 REGHEXCTRLK	2
26	53446	PIN, 5/16-18 HOOD LATCH	2
27	138538	WASHER, REGINTLK, .820X.81X.03	2
28	45174	NUT, 5/16-18 HEXWDFLLK WHIZ	2
29	312306	BAFFLE CONSOLE	1
30	300314	SCREW, 1/4-20X.88 WAHHTAP	2
31	120992	WASHER, FLAT .281X.63X.065	2
32	1502	NUT, 1/4-20 REGHEXCTRLK	2
33	52881-850	HOOD	1
34	56304	EDGING,WIDE	27.5*
35	*	ASSY.GRILLE G-12	1
36	303055	GRILLE	1
39	63225	SCREW, 1/4-20X1.25 WAHHC	4
40	50352	NUT, 1/4-20 WDFLLK TOPLOCK	4
41	302073	LENS,CLEAR W/O TABS NO LOGO	1
42	57786	SCREW, #6 X .50 PLASTITE	4
43	301894-853	SUPPORT, GRILLE RH	1
44	301895-853	SUPPORT, GRILLE LH	1
45	56021	SCREW, 1/4-14X .75 SLWATAP	6
46	36149	BOLT, .375X .500 HHSX 5/16-18	2
47	1488	NUT, 5/16-18 REGHEXCTRLK	2
48	310746	LANYARD,HOOD	1
49	50352	NUT, 1/4-20 WDFLLK TOPLOCK	1
50	301452	FOIL, HEAT REFLECTOR	2
51	311465	COVER STEERING SHAFT	1
52	301251	STEERING WHEEL	1
53	301413	SPACER FOAM	1
54	456378	ROLL PIN	1
55	329758	PARTS MANUAL	1
56	329757	OPERATOR'S MANUAL (GERMAN)	1
57	327627	GRASS CATCHER MANUAL	1
58	323588	AIR ASSIST MANUAL (ENGLISH)	1
59	324360	AIR ASSIST MANUAL (FRENCH)	1
60	327312	AIR ASSIST MANUAL (GERMAN)	1

* ORDER INDIVIDUAL PARTS.

40" LAWN TRACTOR MODEL D3560-210

CHASSIS & HOOD ASSEMBLY (REAR)

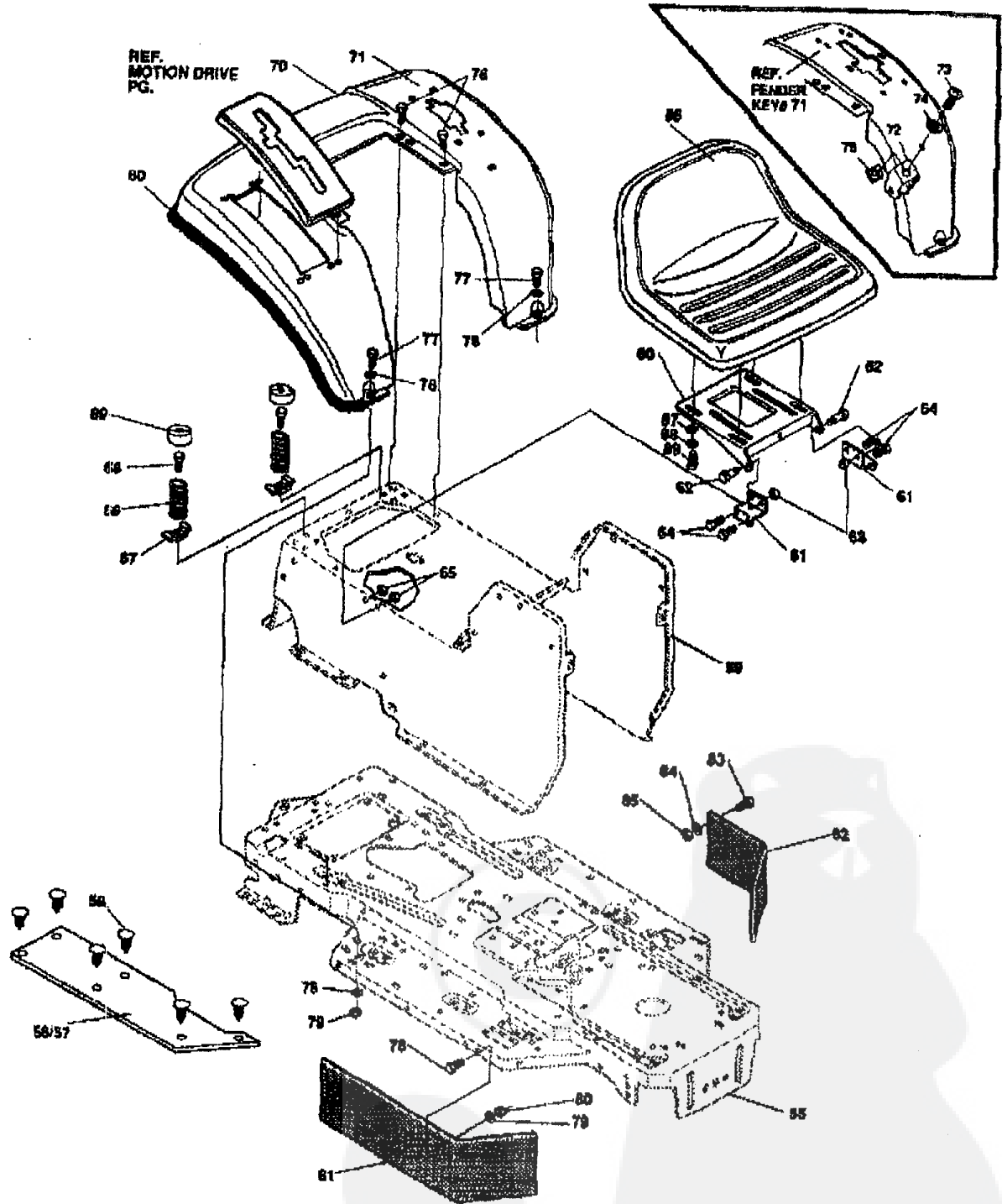

NOTE: ALWAYS USE ORIGINAL EQUIPMENT PARTS. Use of service/replacement parts other than original equipment parts may void your warranty.

ALL UNNUMBERED ITEMS ARE INTERCHANGEABLE WITH OPPOSITE SIDE

325853A

40" LAWN TRACTOR MODEL D3560-210

KEY#	PART#	DESCRIPTION	QTY.
55	326579-860	FRAME, LF MAIN 930/4960 DRILLED	1
56	310005	FOOTPAD L/H	1
57	310006	FOOTPAD R/H	1
58	309235	FASTENER RATCHET	12
59	309665-860	CONSOLE GENERIC SOF	1
60	58357-860	PLATE, SEAT	1
61	310680-860	BRACKET, F-5 SEAT SUPPORT	2
62	20507	BOLT, .437X .156 HHSM 5/16-18	2
63	1498	NUT, 5/16-18 REGHEXCTRLK	2
64	48901	SCREW, 5/16-18X .63 HHC	4
65	1498	NUT, 5/16-18 REGHEXCTRLK	4
66	57153	SPRING, SEAT 2.63LG, 1.49OD	2
67	1941	CLAMP, SPRING 1.17"ID	2
68	44811	SCREW, 1/4-20X .75 HXWATAP	2
69	56907	COVER, SEAT SPRING 1.51DX1.0LG	2
70	A	FENDER ASM F-5 SUSP.	1
71	309653-860	FENDER F5 SUSP	1
72	300298	CLEVIS	1
73	439455	SCREW, 5/16-18X.56 PHPNMA	1
74	301551	WASHER, .344DX1.50DX.09	1
75	120373	NUT, 5/16-18 SQ.	1
76	995346	SCREW, 1/4-20X .50 WAHHTAP	4
77	122017	SCREW, 5/16-18X1.00 HHC	2
78	446363	WASHER, FLAT .375X.89X.082	4
79	1498	NUT, 5/16-18 REGHEXCTRLK	2
80	55021	TRIM, STRIP, BLACK	77.5'
81	305386	BELT GUARD 7" X 28.03"	1
82	305354	BELT GUARD 7" X 15.64"	1
83	57034	SCREW, 10-24 X .63 TRHMA	10
84	1501	WASHER, FLAT .203 X .58 X .040	10
85	271186	NUT, #10-24 HEXKEPS	10
86	310384	SEAT, GENERIC	1
87	120393	WASHER, FLAT .344X.69X.065	4
88	120638	WASHER, HVSPTLK .328X.60X.04	4
89	122007	SCREW 5/16-18X.75 HHC	4

* ORDER INDIVIDUAL PARTS.

40" LAWN TRACTOR MODEL D3560-210

MOWER SUSPENSION

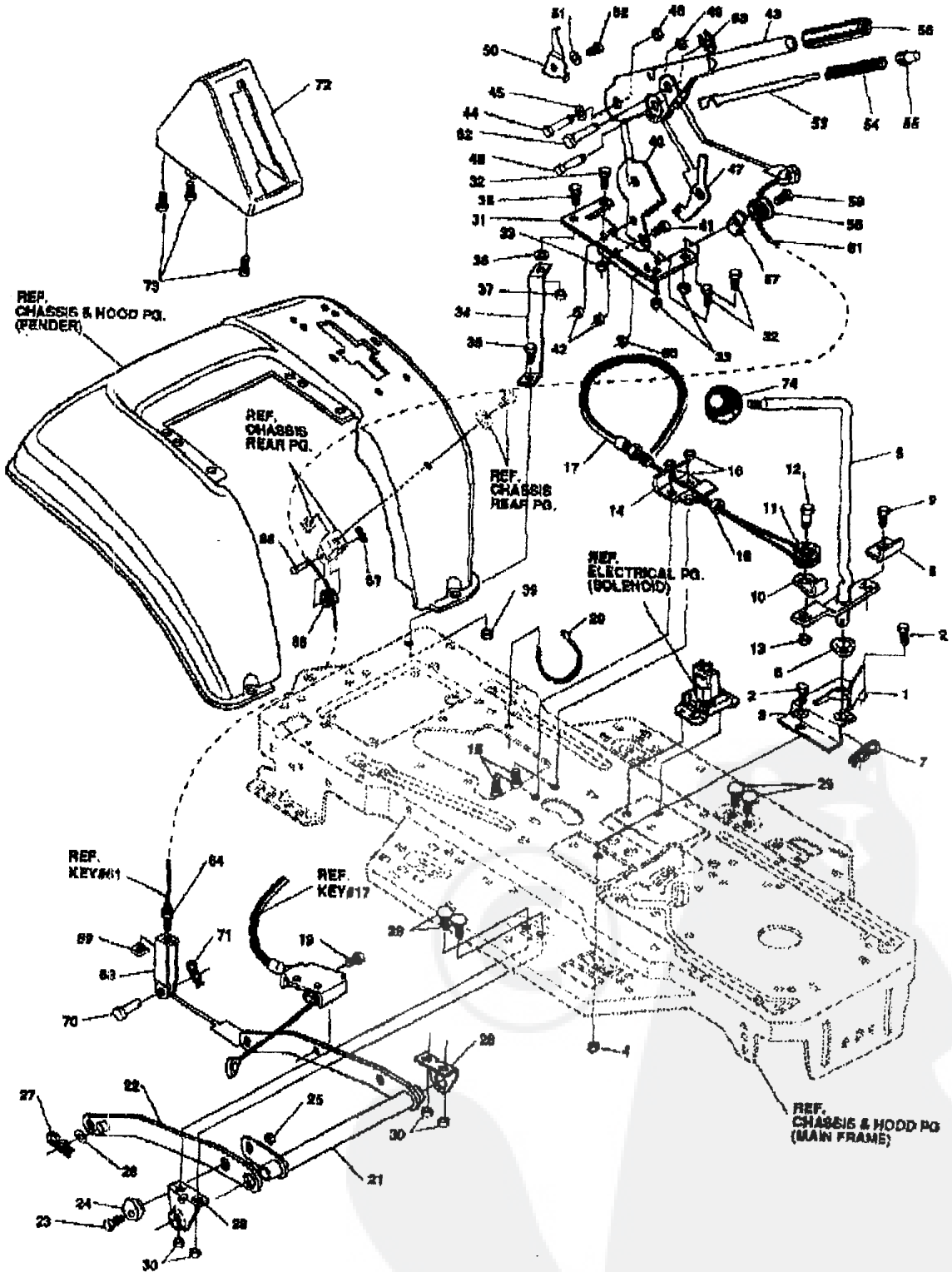

NOTE: ALWAYS USE ORIGINAL EQUIPMENT PARTS. Use of service/replacement parts other than original equipment parts may void your warranty.

ALL UNNUMBERED ITEMS ARE INTERCHANGEABLE WITH OPPOSITE SIDE

325815C

40" LAWN TRACTOR MODEL D3560-210

KEY#	PART#	DESCRIPTION	QTY.
1	320075-853	BRACKET,CLUT-ENGAGELEVER	1
2	180078	SCREW, 5/16-18X1.00 HHC	2
3	120393	WASHER, FLAT .344X.89X.085	2
4	1498	NUT, 5/16-18 REGHEXCTRLK	2
5	304791	ASSY,CLUTCH LEVER	1
6	50148	BEARING,FL. 50310X.82800	1
7	8260	PIN, HAIR .091 DIA X1.88LG	1
8	318341	BRACKET,SWITCH ENGAGE	1
9	35498	SCREW, 5/16-18X .75 WAHTAP	1
10	1289	BRKT,CABLE RETAINER	1
11	48308	PULLEY, .806X.305 PM	1
12	58336	BOLT, .375X .375 HHSH 1/4-20	1
13	1502	NUT, 1/4-20 REGHEXCTRLK	1
14	300698-853	BRKT, FRAME CABLE	1
15	180020	SCREW, 1/4-20X .75 HHC	2
16	1502	NUT, 1/4-20 REGHEXCTRLK	2
17	301503	ASSY,CABLE, BLADE ENGAGE	1
18	120813	NUT, 1/4-28 HJAM	1
19	35498	SCREW, 5/16-18X .75 WAHTAP	1
20	57444	TIE, CABLE BLACK NYLON	1
21	300158-853	ASSY,REAR LIFT	1
22	300169-853	ASSY,LINK,RIGHT SIDE	1
23	180079	SCREW, 5/16-18X1.00 HHC	1
24	58247	ADJUSTING NUT	1
25	1498	NUT, 5/16-18 REGHEXCTRLK	3
26	417098	WASHER, FLAT .531X1.06X.095	2
27	8260	PIN, HAIR .091 DIA X1.88LG	2
28	58248-853	BRKT,REAR,HANG,SUSP	2
29	126211	BOLT, 5/16-18X .63 CARR	4
30	1498	NUT, 5/16-18 REGHEXCTRLK	4
31	313428	BRACKET,HGT/ADJUST SUPPORT	1
32	180077	SCREW, 5/16-18X .75 HHC	3
33	1498	NUT, 5/16-18 REGHEXCTRLK	3
34	300336-880	BRACE, FENDER F-5 SUS	1
35	180078	SCREW, 5/16-18X1.00 HHC	1
36	45602	WASHER, FLAT .333X .87X.118	1
37	1498	NUT, 5/16-18 REGHEXCTRLK	1
38	180079	SCREW, 5/16-18X1.00 HHC	1
39	1498	NUT, 5/16-18 REGHEXCTRLK	1
40	301238	QUADRANT,HEIGHT ADJUST	1
41	180077	SCREW, 5/16-18X .75 HHC	2
42	1498	NUT, 5/16-18 REGHEXCTRLK	2
43	322292-853	HANDLE,LIFT SHORT BLK	1
44	300171	BOLT, .500X .270 HHSH 5/16-18	1
45	996418	WASHER, FLAT .508X .75X.024	1
46	44108	NUT, 5/16-18 HWDFLCTRLK	1
47	301239	PAWL, HEIGHT ADJUST	1
48	300171	BOLT, .500X .270 HHSH 5/16-18	1
49	44108	NUT, 5/16-18 HWDFLCTRLK	1
50	9435	POINTER Z-PL	1
51	138479	WASHER, EXLK .195X.41X.03	1
52	35287	SCREW, #8-32X .38 HHVAT	1
53	303027	ROD,ACTUATOR-SHORT	1
54	58326	SPRING, HEIGHT ADJUST	1
55	58325	KNOB, HGT ADJ PUSH BUTTON	1
56	58329	GRIP, .750 OD W/ HOLE	1
57	9149	BRKT, CABLE RETAIN	1
58	48308	PULLEY, .806X.305 NYLON	1
59	58336	BOLT, .375X .375 HHSH 1/4-20	1
60	1502	NUT, 1/4-20 REGHEXCTRLK	1
61	314177	CABLE, LIFT 23.30 F-5 20X8-8	1
62	300310	PIN,CLEVIS .310DIA+.475LG	1
63	300311	RING, RET E .31X.24	1
64	120376	NUT 1/4-20 REGHEX	1
65	48308	PULLEY, .806X.305 NYLON	1
66	300317	PIN, CLEVIS .38 DIA X1.00 LG	1
67	8260	PIN, HAIR .091 DIA X1.88LG	1
68	9405	CLEVIS, LIFT CABLE	1
69	120372	NUT, 1/4-20 REGSO	1
70	39522	PIN,CLEVIS .312 X .812	1
71	121222	PIN, COTTER .060/.080X.75LG	1
72	300335	LIFT COVER-39" F5	1
73	300340	SCREW, #10 X .75 HHPLAST	3
74	55514	KNOB,ROUND 1.50 BLACK	1

40" LAWN TRACTOR MODEL D3560-210

STEERING ASSEMBLY

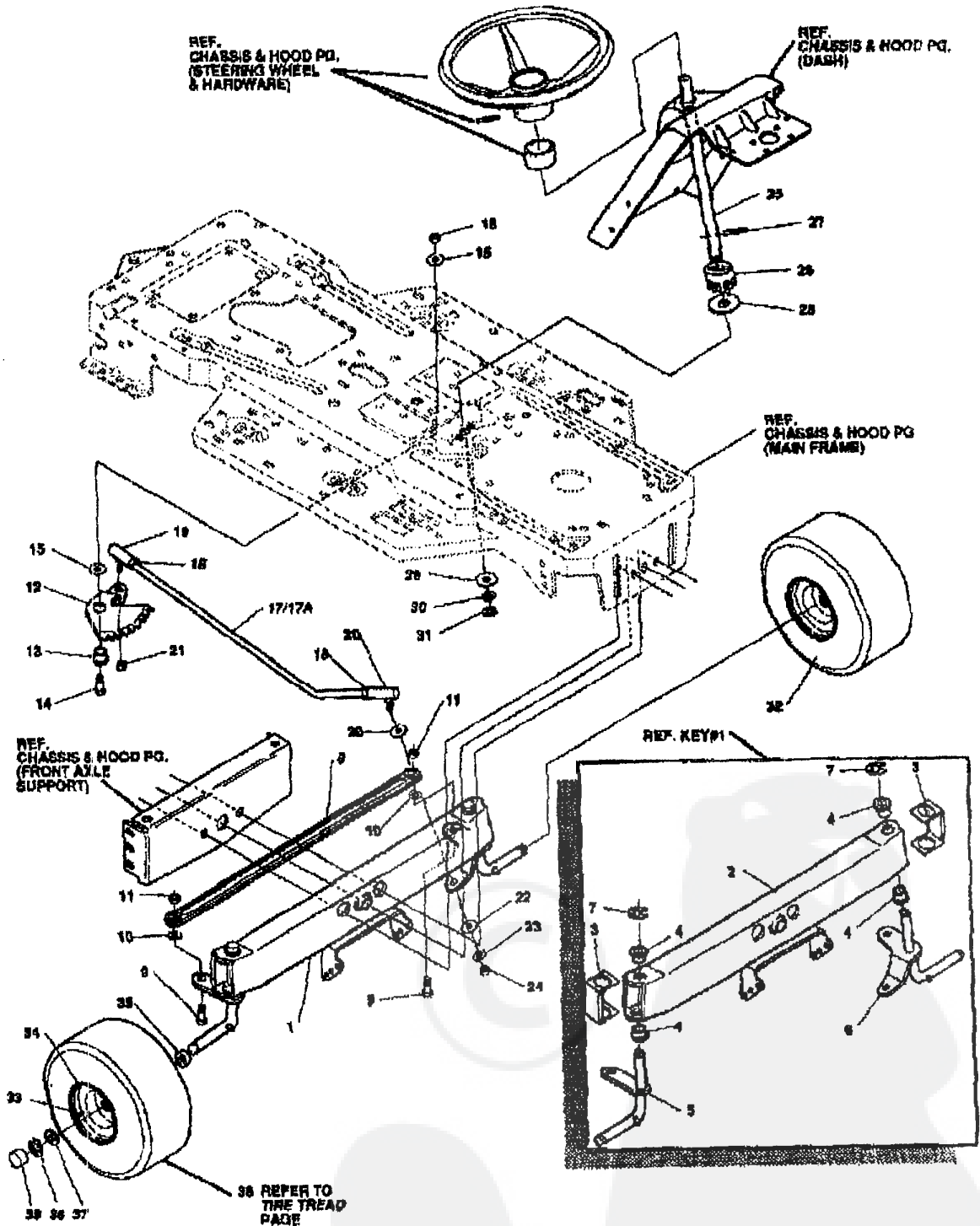

NOTE: ALWAYS USE ORIGINAL EQUIPMENT PARTS. Use of service/replacement parts other than original equipment parts may void your warranty.

ALL UNNUMBERED ITEMS ARE INTERCHANGEABLE WITH OPPOSITE SIDE

315136F

40" LAWN TRACTOR MODEL D3560-210

KEY#	PART#	DESCRIPTION	QTY.
1	A	ASSY.AXLE FRONT	1
2	300272-853	AXLE, FRONT	1
3	53973-853	AXLE COVER	1
4	52407	SPINDLE BEARING	2
5	302926	SPINDLE RH	4
6	915886	SPINDLE LH	1
7	96625	RING, RETEX .57X.05TRU5133-75	1
8	304590	TIE ROD ASSY 19.81LG	2
9	180128	SCREW, 3/8-16X1.75 HHC	1
10	120382	WASHER, REGSPTLK.393X.68X.10	2
11	120377	NUT, 3/8-16 REGHEX	2
12	58289	SECTOR, STEERING LF	2
13	52406	BRNG, FL ECC.510IDK .888ODX .58	1
14	180177	SCREW, 1/2-13X1.50 HHC	1
15	22265	WASHER, FLAT .515X1.38X.119	1
16	1500	NUT, 1/2-13 REGHCTRLK	2
17	300146	DRAGLINK ASSEMBLY	1
17A	58291	STEERING LINK	1
18	124925	NUT, 3/8-24 REGHEX,JAM	1
19	57158	BALL JOINT 3/8 THD SHORT STUD	2
20	21276	BALL JOINT 3/8 TH'D LONG STUD	1
21	40692	NUT, 3/8-24 WDFLHLK	1
22	120396	WASHER, FLAT .531X1.05X.095	1
23	120382	WASHER, REGSPTLK.393X.68X.10	2
24	120369	NUT, 3/8-24 REGHEX	1
25	58243	SHAFT, STEERING LF	1
26	58244	PINION, STEERING LF	1
27	58274	PIN,DOWEL .2600 OD+1.75	1
28	301410	BRNG, FL .782IDK1.061ODK .24	1
29	301398	WASHER, FORMED1.195X1.53X.12	1
30	21692	WASHER, FLAT .785X1.25X.042	1
31	36825	RING, RETEX .57X.05TRU5133-75	1
32	A	TIRE & RIM, PU 15X6.0X6	1
33	24167	VALVE STEM	2
34	39529	WHEEL W/BRG.	1
35	39979	BEARING,FL1.38OD+.753ID	1
36	301140	REFER TO TIRE TREAD PAGE	1
37	842	WASHER, FLAT .755X1.31X.075	1
38	36825	RING, RETEX .57X.05TRU5133-75	4
39	40334	CAP, 1.500ID X 7/8LG HUB	2

* ORDER INDIVIDUAL PARTS.



40" LAWN TRACTOR MODEL D3560-210

MOTION DRIVE ASSEMBLY

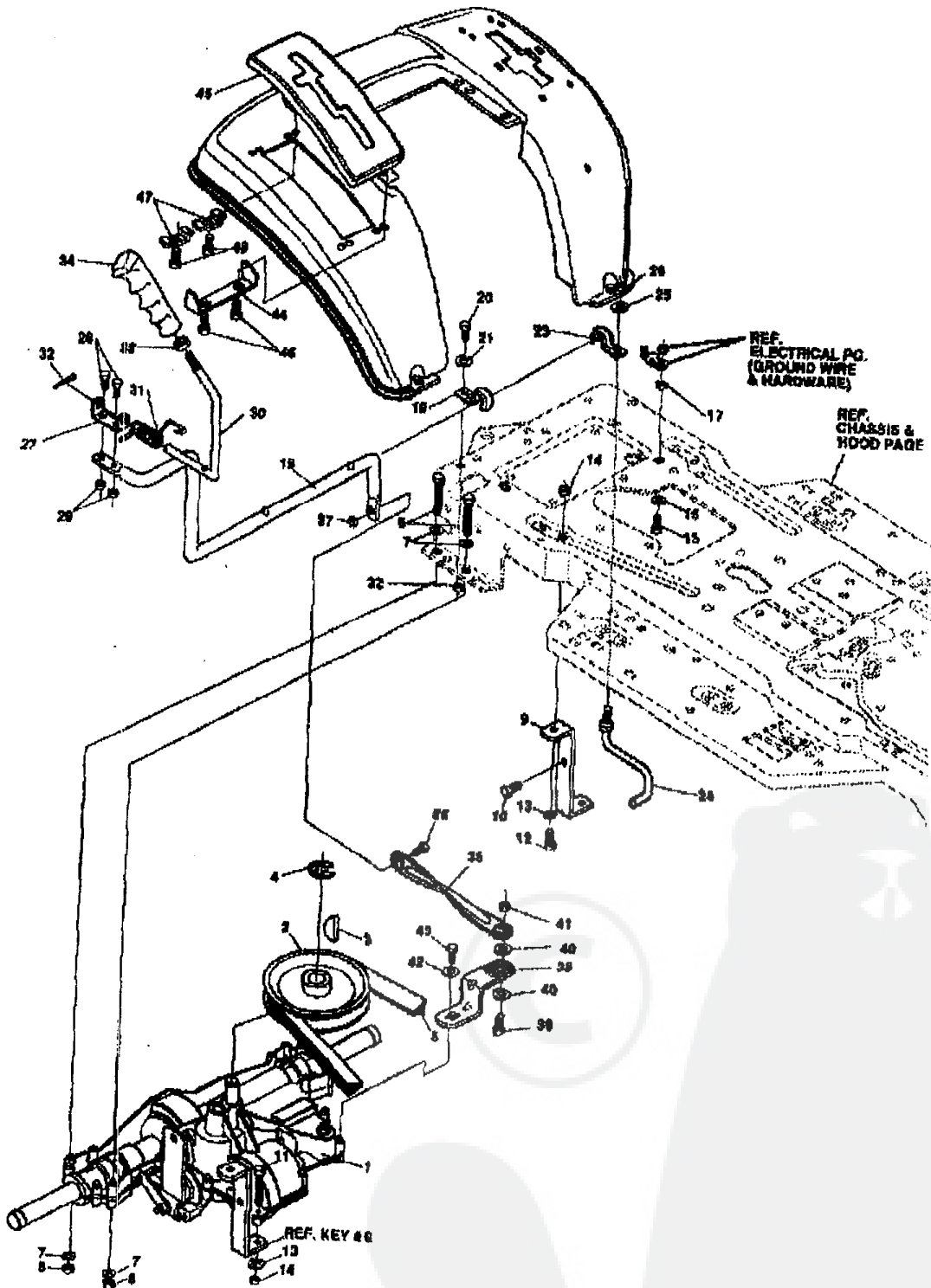

NOTE: ALWAYS USE ORIGINAL EQUIPMENT PARTS. Use of service/replacement parts other than original equipment parts may void your warranty.

ALL UNNUMBERED ITEMS ARE INTERCHANGEABLE WITH OPPOSITE SIDE

326581A

40" LAWN TRACTOR MODEL D3560-210

KEY#	PART#	DESCRIPTION	QTY.
1	A	TRANSAXLE P840-5 2WS	1
2	302745	PULLEY	1
3	3021	KEY, WDRF 606 .750X.187X.312	1
4	22053	RING, RETEX .58X.04TRUS100-62	1
5	814120	BELT	1
6	180089	SCREW, 5/16-18X2.25 HHC	4
7	120393	WASHER, FLAT .344X.89X.065	6
8	1498	NUT, 5/16-18 REGHEXCTRLK	4
9	325202	MF STABILIZER BRKT	1
10	50947	SCREW, 3/8-16X1.25 WAHHTAP	1
11	122065	SCREW, 5/16-18X 2.00 HHC	1
12	122017	SCREW, 5/16-18X1.00 HHC	1
13	120393	WASHER, FLAT .344X.89X.065	2
14	1498	NUT, 5/16-18 REGHEXCTRLK	2
15	122007	SCREW, 5/16-18X .75 HHC	1
16	138538	WASHER, REGINTLK.820X.61X.03	1
17	1498	NUT, 5/16-18 REGHEXCTRLK	1
18	825302	LEVER,SHIFT,LWR 940 LF	1
19	310347-853	CLIP-SHIFT LEVER .62 ROD	1
20	180077	SCREW, 5/16-18X .75 HHC	1
21	998416	WASHER, FLAT .391X1.00X.125	1
22	1498	NUT, 5/16-18 REGHEXCTRLK	1
23	310347-853	CLIP-SHIFT LEVER .62 ROD	1
24	57259	GUIDE, BELT 5/16-18THD	1
25	998416	WASHER, FLAT .391X1.00X.125	1
26	1498	NUT, 5/16-18 REGHEXCTRLK	1
27	310356	PIVOT BRKT LEVER	1
28	180018	SCREW, 1/4-20X .82 HHC	2
29	1502	NUT, 1/4-20 REGHEXCTRLK	2
30	809695	LEVER, SHIFT UPPER 9F 1/2-13TH	1
31	310285	SPRING, TORS. .56X.95X.095	1
32	137185	PIN, COTTER .125 DIA X1.00LG	1
33	120235	NUT, 1/2-13 HEXJAM	1
34	308690	HANDLE 1/2-13 MOLOED	1
35	325182	LINK TIE ROD SHIFTER P840 LF	1
36	180124	SCREW, 3/8-16X1.25 HHC	1
37	1498	NUT, 3/8-16 REGHXCTRLK	1
38	827460	BRACKET,SHIFT 5SP FEN HT	1
39	180124	SCREW, 3/8-16X1.25 HHC	1
40	120394	WASHER, FLAT .406X.81X.065	2
41	1498	NUT, 3/8-16 REGHXCTRLK	1
42	57157	WASHER,.750X.250 5P-TRANSAXLE	1
43	56255	SCREW, 1/4-28X .75 NYLHHC	1
44	311257-853	BRACKET COVER	1
45	311209	COVER PLASTIC	1
46	311531	SCREW,1/4-15X .44/.53 HILOHHWA	2
47	1341	CLAMP SPRING	2
48	311331	SCREW,1/4-15X .44/.53 HILOHHWA	2

* CONTACT YOUR NEAREST TRANSAXLE DEALER FOR PARTS AND SERVICE.

40" LAWN TRACTOR MODEL D3560-210

MOTION DRIVE ASSEMBLY

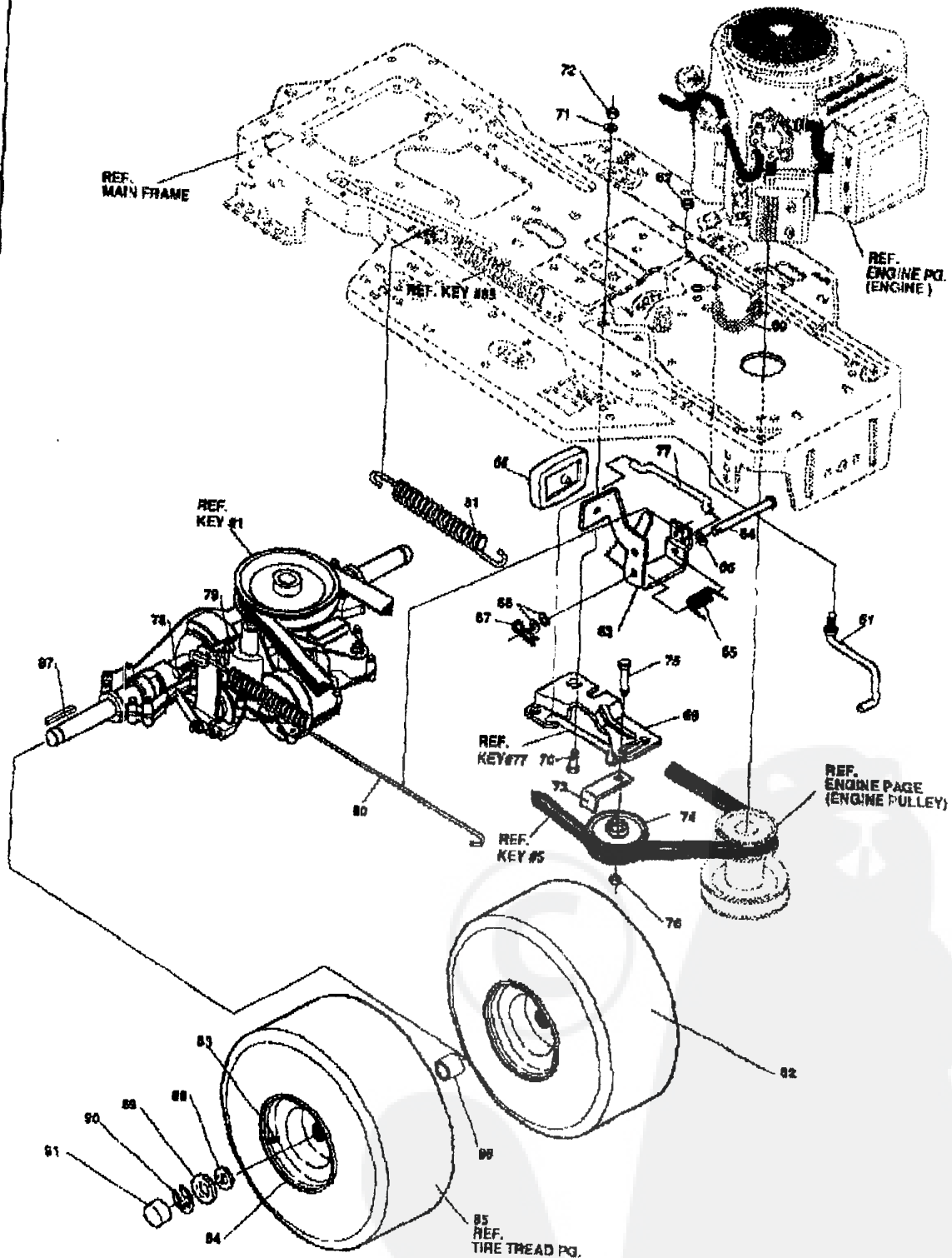

NOTE: ALWAYS USE ORIGINAL EQUIPMENT PARTS. Use of service/replacement parts other than original equipment parts may void your warranty.

ALL UNNUMBERED ITEMS ARE INTERCHANGEABLE WITH OPPOSITE SIDE

3265B1A

40" LAWN TRACTOR MODEL D3560-210

KEY#	PART#	DESCRIPTION	QTY.
60	321514	SPRING BIAS DRAGLINK	1
61	304016	GUIDE BELT	1
62	1498	NUT, 5/16-18 REGHEXCTRLK	1
63	326942	PEDAL ASSY, BRAKE/CLUTCH LF	1
64	319876	PIN, CLEVIS	1
65	57847	SPRING, BRAKE PEDAL	1
66	2968	WASHER, FLAT .804X .75X .050	3
67	56180	PIN, HAIR	1
68	48180	PAD, CLUTCH BRAKE W/PRINTING	1
69	320381	ARM, IDLER TRACTION DR. LF	1
70	300793	BOLT, .625X .135 HSH 5/16-18	1
71	45602	WASHER, FLAT .339X .87X .119	1
72	1498	NUT, 5/16-18 REGHEXCTRLK	1
73	39659	RETAINER, STRAP BELT	1
74	35374	PULLEY, IDLER V4L 3.06X .62	1
75	45892	BOLT, 3/8-16X1.50 CARR	1
76	1499	NUT, 3/8-16 REGHXCTRLK	1
77	57204	ROD, CLUTCH	1
78	328131	BOLT, .496X .31 HSH 5/16-18	1
79	1498	NUT, 5/16-18 REGHEXCTRLK	1
80	325810	SPRING BRAKE 31.12 P940 LF	1
81	58359	SPRING, CLUTCH .113X .750X .75	1
82	A	TIRE & RIM, PU 20X10-8 GENERIC	2
83	24167	VALVE STEM	
84	301366	RIM, WHEEL 20X9.00	
85		REFER TO TIRE TREAD PAGE	
86	301566	SPACER	2
87	52928	KEY	2
88	642	WASHER, FLAT .755X1.31X.075	4
89	42815	WASHER, FLAT .755X1.53X.07	2
90	36625	RING, RETEX	2
91	40394	CAP, HUB	2

* ORDER INDIVIDUAL PARTS.

40" LAWN TRACTOR MODEL D3560-210

ENGINE & CONTROL ASSEMBLY

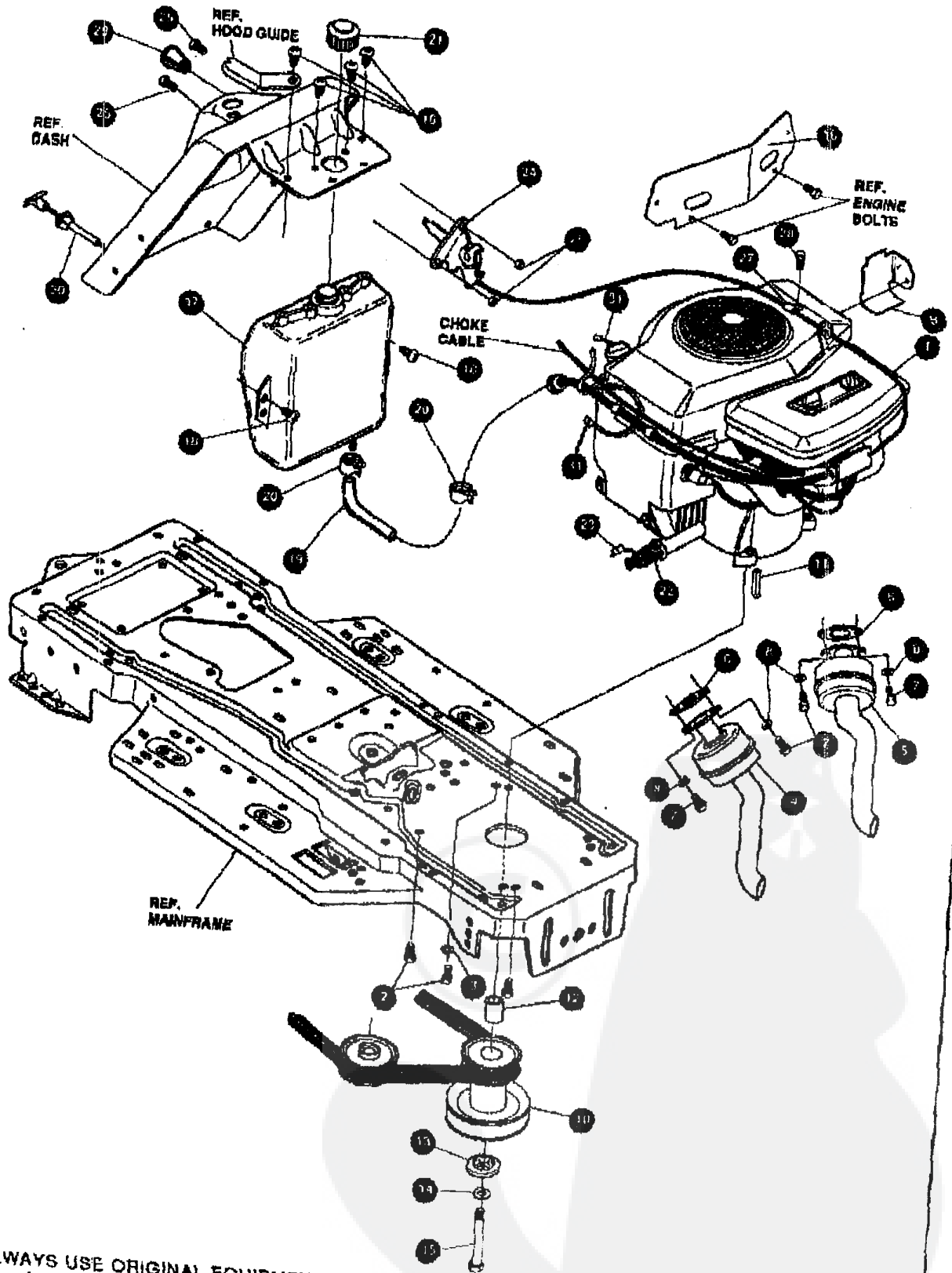

NOTE: ALWAYS USE ORIGINAL EQUIPMENT PARTS. Use of service/replacement parts other than original equipment parts may void your warranty.

ALL UNNUMBERED ITEMS ARE INTERCHANGEABLE WITH OPPOSITE SIDE

40" LAWN TRACTOR MODEL D3560-210

KEY#	PART#	DESCRIPTION	QTY.
1	ENGINE	14-18 HPBS TWIN OPP (BEE ENGINE MANUAL)	1
2	50847	SCREW, 3/8-16X1.25 WAHHTAP	1
3	136488	WASHER, EXLK.384X.69X.04	4
4	68144	MUFFLER RH	1
5	58145	MUFFLER, LH	1
6	58640	GASKET, MUFFLER	1
7	180020	SCREW, 1/4-20X.75 HHC GR5	2
8	120380	WASHER, REGSPTLK.263X.49X.07	4
9	56470-859	DEFLECTOR, COOL AIR BLK	4
10	315317	PULLEY, ENG 3.0DX4.0LGX6.00	1
11	303151	KEY, SQUARE .249SQX4.50 LG	1
12	304246	SPACER, 1.01X1.484 ENGIN PULLEY	1
13	56481	WASHER, .880DX1.380DX.437PILOT	1
14	120383	WASHER, REGSPTLK.459X.78X.12	1
15	433145	SCREW, 7/16-20X4.25 HHC GR5 P	1
16	52796-853	BULKHEAD HOOD H-7,8	1
17	314992	TANK, FUEL 23AL CLEAR	1
18	49050	SCREW, 1/4-10X.75PHPNTAPGR2	1
19	47452	TUBING, .25X.50X BULK GAS LINE	6
20	47345	CLAMP, FUEL LINE	15.5'
21	48704	GAS CAP 1-1/2-7 THD	2
22	325547	OIL DRAIN ITW	1
23	327422	CAP OIL DRAIN	1
24	300456	CONTROL, THROTTLE 31LG TWIN BS	1
25	320553	SCREW, 10-24X.63PHPNMA GR2BK	1
26	271166	NUT, #10-24 HEXKEPS	2
27	56538	RETAINER, WIRE	2
28	35258	SCREW, 10-24X.38 SLHWATAPGR2	1
29	50807	KNOB, ROUND THROTTLE	1
30	300452	CONTROL, CHOKE 47.13LG PAN	1
31	57444	TIE, CABLE BLACK NYLON 5.62L	2

40" LAWN TRACTOR MODEL D3560-210

PRE-PAINTED DECK

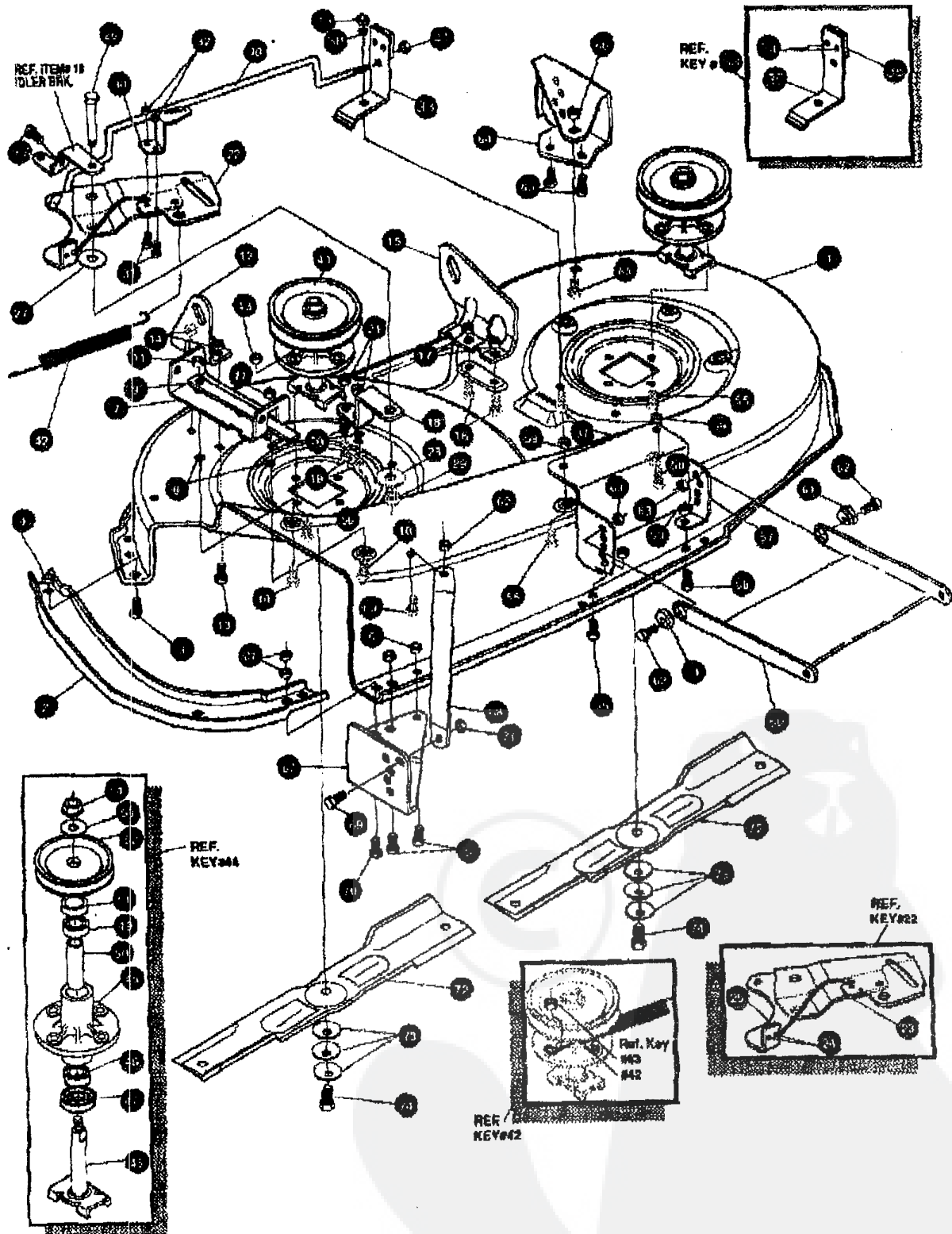

NOTE: ALWAYS USE ORIGINAL EQUIPMENT PARTS. Use of service/replacement parts other than original equipment parts may void your warranty.

ALL UNNUMBERED ITEMS ARE INTERCHANGEABLE WITH OPPOSITE SIDE

324063H

40" LAWN TRACTOR MODEL D3560-210

KEY#	PART#	DESCRIPTION	QTY.
1.	325103-853	MS MOWER DECKS, 40" LF/EURO	1
2.	325480-853	TOE GUARD	1
3.	180075	SCREW, 5/16-18X .63 HHC GR5	1
4.	1498	NUT, 5/16-18 REGHEXCTRLK	1
5.	180075	SCREW, 5/16-18X .60 HHC GR5	2
6.	1498	NUT, 5/16-18 REGHEXCTRLK	2
7.	302384	BRACKET CHUTE MOUNT	1
8.	120393	WASHER, FLAT .344X.69X.065	2
9.	322330	LEVER ASSY	1
10.	180075	SCREW, 5/16-18X .63 HHC GR5	2
11.	1498	NUT, 5/16-18 REGHEXCTRLK	2
12.	313829	MS BRACKET, RH LIFT REAR	1
13.	180077	SCREW, 5/16-18X .75 HHC GR5	2
14.	1498	NUT, 5/16-18 REGHEXCTRLK	2
15.	310667	MS/MP BRACKET, LH LIFT REAR	1
16.	180077	SCREW, 5/16-18X .75 HHC GR5	2
17.	1498	NUT, 5/16-18 REGHEXCTRLK	2
18.	325893-853	BRACE IDLER	1
18A	308231	SCREW, 1/4-20X1.25 HHWATAP	1
19.	180077	SCREW, 5/16-18X .75 HHC GR5	2
20.	120393	WASHER, FLAT .344X.69X.065	2
21.	44108	NUT, 5/16-18 HWDFLCTRLK	2
22.	320576-853	SF IDLER ARM ASSEMBLY	1
23.	322116-853	MP/MM ARM IDLER 40/49" DECK	1
24.	41601	RIVET, OVSET .187DIA X .50 LG ST	2
25.	308973	BRAKE PAD - HARD - 232AF	1
26.	304420	BOLT, .600X2.15 NXHDCPSH GR2-	1
27.	896307	WASHER, FLAT .391X1.00X.209	1
28.	896418	WASHER, FLAT .391X1.00X.125	2
29.	45171	NUT, 3/8-18 HWDFL WHIZ-LOCK ZN	1
30.	326249-853	MP BRACKET, EXTENSION IDLER	1
31.	180075	SCREW, 5/16-18X .63 HHC GR2	2
32.	1498	NUT, 5/16-18 REGHEXCTRLK	2
33.	321828	BLADE BRAKE ASSY	1
34.	135624	RIVET TRSET .187DIA X .50 LGST	2
35.	304119-853	BRAKE ARM	1
36.	308973	BRAKE PAD	1
37.	180075	SCREW, 5/16-18X .63 HHC	1
38.	120393	WASHER, FLAT .344X.69X.065	1
39.	1498	NUT, 5/16-18 REGHEXCTRLK	1
40.	315398	BRAKE ROD	1
41.	1502	NUT, 1/4-20 REGHEXCTRLK	1
42.	95410	SPRING .071 X .62 X 4.37	1
43.	1498	NUT, 5/16-18 REGHEXCTRLK	1
44.	58424-853	SP/SF QUILL ASSY, 38/39/40/43	2
45.	58425	WS SHAFT/SADDLE 38"	1
46.	49562	BRNG, BALL .869ID X 1.675OD X .472	1
47.	50818	MS DUST SHIELD	1
48.	55547	QUILL CASTING (1048)	1
49.	49562	BRNG, BALL .869ID X 1.675OD X .472	1
50.	50818	SPACER, SLEV .689X .88X3.797	1
51.	51449	SPACER, SLEV .672X .99X .438PM	1
52.	56390	BF/BP PULLEY 28/38" QUILL V5L	1
53.	56365	WASHER, SPECIAL QUILL	1
54.	1282	NUT, 7/16-20 WDFLLK	1
55.	50634	SCREW, 5/16-18X .88 WAHTAP	7
56.	300345	SCREW, 5/16-18X1.38 WATAPGR2	1
57.	318445-853	MS BRACKET, 40 LF FRONT DECK	1
58.	180075	SCREW, 5/16-18X .63 HHC GR5	4
59.	1498	NUT, 5/16-18 REGHEXCTRLK	4
60.	58306-853	MS, MP BRACKET, LINK DECK FRONT	1
61.	58247	ADJUSTING NUT	2
62.	122017	SCREW, 5/16-18X1.00 HHC GR2	2
63.	1498	NUT, 5/16-18 REGHEXCTRLK	2
64.	304426	BRACKET, GAGE WHEEL L.H.	1
65.	180075	SCREW, 5/16-18X .63 HHC GR5	3
66.	1498	NUT, 5/16-18 REGHEXCTRLK	3
67.	317041-853	BRACKET, GAGE WHEEL R.H. FRNT	1
68.	314282-853	BRACKET, STABILIZER	1
69.	180075	SCREW, 5/16-18X .83 HHC GR5	1
70.	12685	SCREW, 5/16-18X1.25 HHCFY YZ	1
71.	1498	NUT, 5/16-18 REGHEXCTRLK	3
72.	309070	BLADE, 20 3/2 HIGH-LIFT	2
73.	2483	WASHER, .39ID X 1.25OD X .07 BELLVIL	6
74.	39573	SCREW, 3/8-24X1.00 NYLHHCGR5	2

40" LAWN TRACTOR MODEL D3560-210

FINAL DECK ASSEMBLY

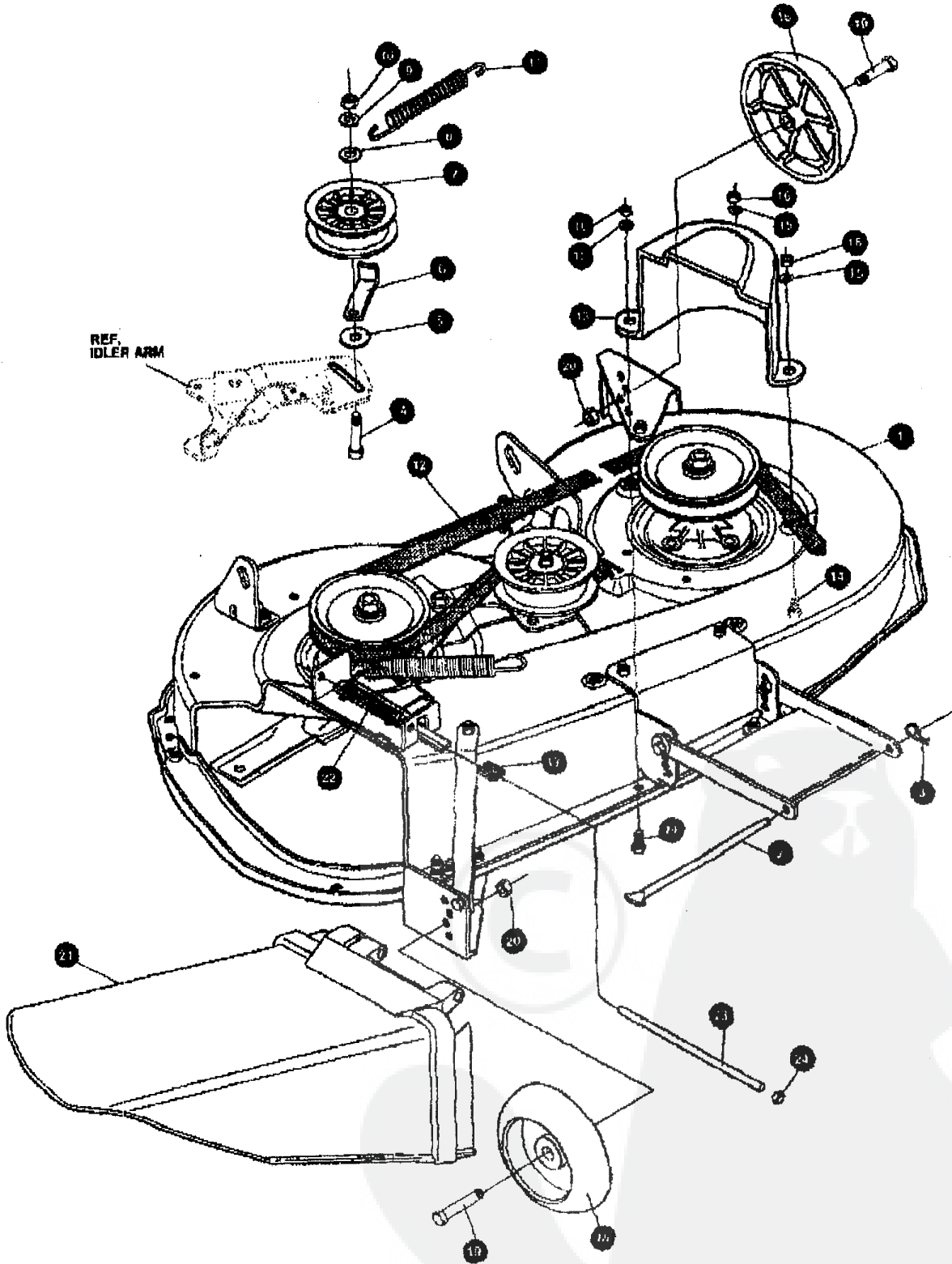

NOTE: ALWAYS USE ORIGINAL EQUIPMENT PARTS Use of service/replacement parts other than original equipment parts may void your warranty.

ALL UNNUMBERED ITEMS ARE INTERCHANGEABLE WITH OPPOSITE SIDE

325685A

40" LAWN TRACTOR MODEL D3560-210

KEY#	PART#	DESCRIPTION	QTY.
1.	^	DECK, 40" MOWER 2-WH DOMESTIC	1
2.	55908	ROD, DECK HITCH	1
3.	8260	PIN, HAIR .091 DIA X 1.56 LG	1
4.	57325	BOLT, 3/8-18 X 2.00 CARR	1
5.	25210	WASHER, FLAT .392 X 1.25 X .09	1
6.	1346	RETAINER, BELT	1
7.	310328	PULLEY, IDLER BFF 4.00 WIDE FL	1
8.	898307	WASHER, FLAT .391 X 1.00 X .208	1
9.	120352	WASHER, REG SP TLK .393 X .68 X .10	1
10.	120377	NUT, 3/8-16 REG HEX	1
11.	300473	SPRING, TENSION 7.52 LG + 17 LB IN	1
12.	319005	BELT, V 5L 81.00 DECK 40 LF	1
13.	325234	GUARD, BELT LH PLASTIC	1
14.	190075	SCREW, 5/16-18 X .63 HHG	3
15.	120393	WASHER, FLAT .344 X .69 X .065	3
16.	1498	NUT, 5/16-18 REG HEX CT RLK	3
17.	42348	GRIP-LEVER	1
18.	302611	GAUGE WHEEL, EURO	2
19.	23763	SHOULDER, BOLT	2
20.	1499	NUT, 3/8-16 REG HEX CT RLK	2
21.	304422	CHUTE, DEFLECTOR 40"-49"	1
22.	314875	SPRING TORSION	1
23.	304424	ROD, PIVOT DECK	1
24.	3535	PUSH NUT	1

^ ORDER DECK KIT# 326035 FOR COMPLETE DECK.

40" LAWN TRACTOR MODEL D3560-210

ELECTRICAL ASSEMBLY

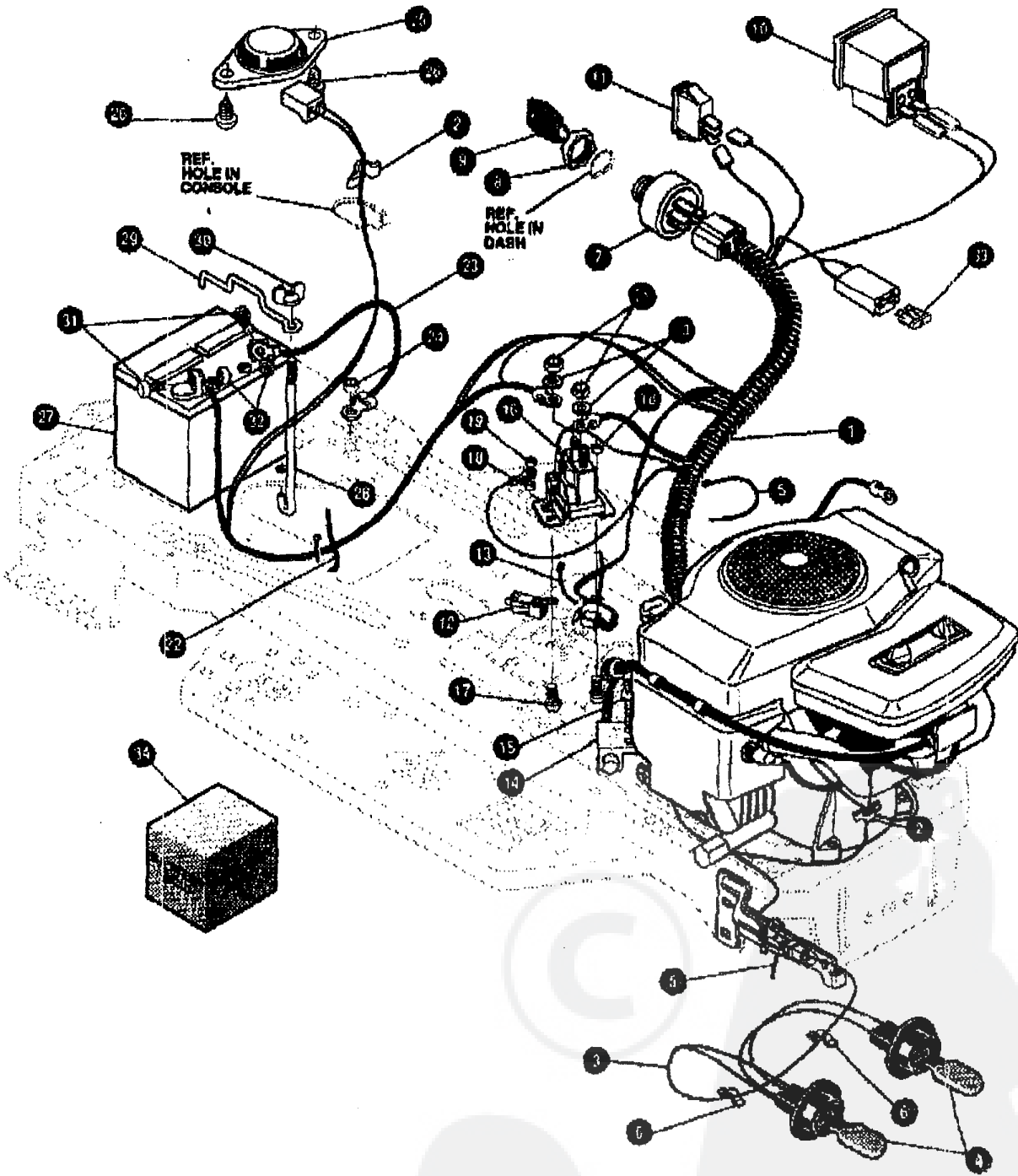

NOTE: ALWAYS USE ORIGINAL EQUIPMENT PARTS. Use of service/replacement parts other than original equipment parts may void your warranty.

ALL UNNUMBERED ITEMS ARE INTERCHANGEABLE WITH OPPOSITE SIDE

325513C

40" LAWN TRACTOR MODEL D3560-210

KEY#	PART#	DESCRIPTION	QTY.
1.	322798	WIRE HARNESS 14-18TWIN OPP DYN	1
2.	41482	PRESS CLIP, 1.380LG, 266ID	2
3.	303084	ASSY.LIGHT WIRE-1/8 TURN	1
4.	52572	BULB, HEADLAMP	2
5.	322685	TIE, CABLE BLACK NYLON 5.62L	2
6.	41482	PRESS CLIP 1.380LG 266ID	2
7.	327355	SWITCH-IGN(AFTER FIRE) 3 POSN	1
8.	327352	NUT, 5/16-32 HXHD IGN SWIT	1
9.	327850	KEY, IGNITION SWITCH	1
10.	300193	AMMETER	1
11.	300394	LIGHT SWITCH ON/OFF PANEL	1
12.	320082	SWITCH, DOUBLE POLE NO/NG BLACK	1
13.	57444	TIE, CABLE BLACK NYLON 5.62L	1
14.	57475	SWITCH, SCR MNT DP NC NO	1
15.	57220	SCREW, #12 X .50 PHPNHTAP	2
16.	53719	SOLENOID	1
17.	187745	SCREW, 1/4-20X .75 HXSEMMA	2
18.	1502	NUT, 1/4-20 REGHEXCTRLK	2
19.	271172	NUT, 1/4-20 REGHEXKEPS	1
20.	138485	WASHER, EXLK .320X.61X.03	2
21.	120368	NUT, 5/16-24 REGHEX	2
22.	57444	TIE, CABLE BLACK NYLON	1
23.	55511	WIRE, GROUND, 12.5'	1
24.	271184	NUT, 5/16-18 HEXKEPS	1
25.	57547	SWITCH, SEAT	1
26.	160505	SCREW, 1/4-20X .38PHPNHMA	2
27.	302257	BATTERY 12VOLT, GENERIC	1
28.	67551	ROD, BATTERY	1
29.	67552	ROD, BATTERY, TOP	1
30.	925232	NUT, WING 1/4-20 NYLON	1
31.	120854	SCREW, 1/4-20X .63 HHC	2
32.	271172	NUT, 1/4-20 REGHEXKEPS	2
33.	302031	FUSE, 15 AMP SPADE TYPE	1
34.	62778-98B	BATTERY ACID, 80 OZ.	1

** SPADE TYPE FUSES ARE INCLUDED WITH THE WIRE HARNESS.

SCHEMATIC DRAWING

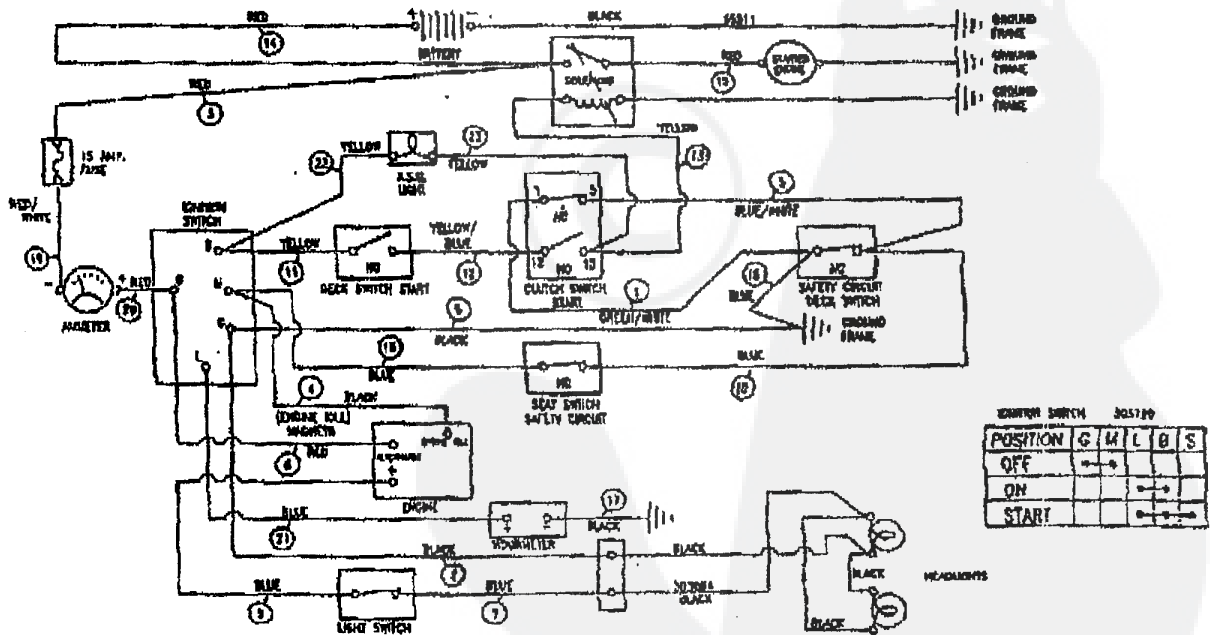

40" LAWN TRACTOR MODEL D3560-210

DECALS (DECORATIVE)

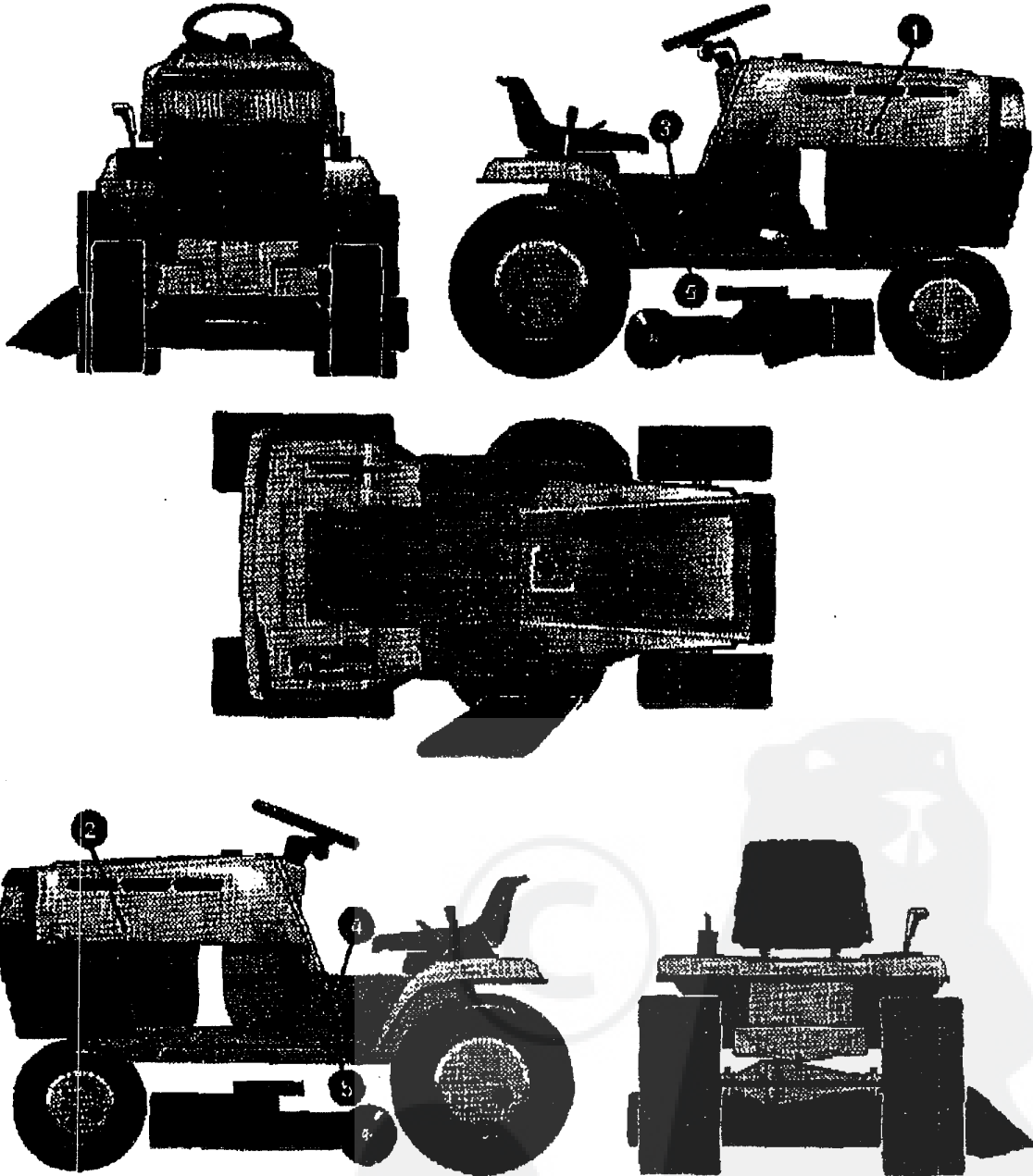

329263A

40" LAWN TRACTOR MODEL D3560-210

KEY#	PART#	DESCRIPTION	QTY.
1.	320746	DECAL, HOOD R-H (UNITECH)	1
2.	320747	DECAL, HOOD L-H (UNITECH)	1
3.	314452	DECAL, CONSOLE RH LARGE FRAME	1
4.	314463	DECAL, CONSOLE LH LARGE FRAME	1
5.	402161	NAMEPLATE, 14/40	2

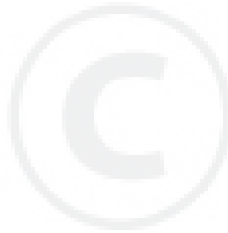

40" LAWN TRACTOR MODEL D3560-210

DECALS (INSTRUCTIONAL)

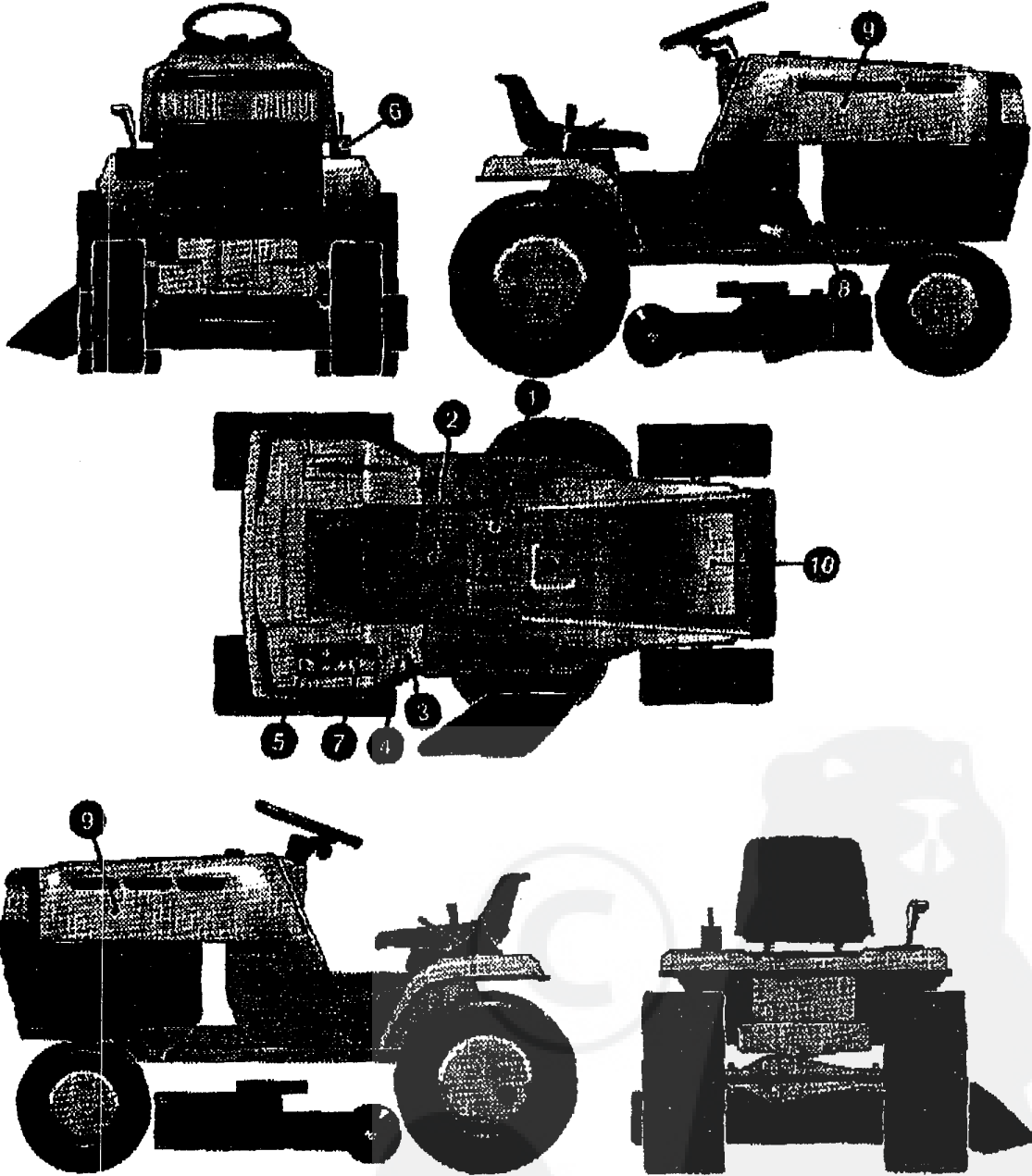

329262A

40" LAWN TRACTOR MODEL D3560-210

KEY#	PART#	DESCRIPTION	QTY.
1.	324534	DECAL, LF DASH LSW/CHOK EXP	1
2.	69524	DECAL, INSTRUCT CONSOLE TOP GER	1
3.	305770	DECAL, CAUTION TRIANGLE EUROPE	1
4.	311066	DECAL, DANGER GERMAN	1
5.	311394	DECAL, SHIFT REV/NEUTRAL	1
6.	324044	DECAL, CUT HEIGHT, 3 POSITION	1
7.	323464	DECAL, SHIFTER POSITION	1
8.	68903	DECAL, BRAKE/CLUTCH ISO	1
9.	55836	PAD, FOAM HOOD SIDE H-67	2
10.	55836	PAD, FOAM HOOD TOP H-67	1
11.		REFERENCE ONLY	1
12.		REFERENCE ONLY	1
13.		REFERENCE ONLY	1

40" LAWN TRACTOR MODEL D3560-210

TREAD PATTERNS

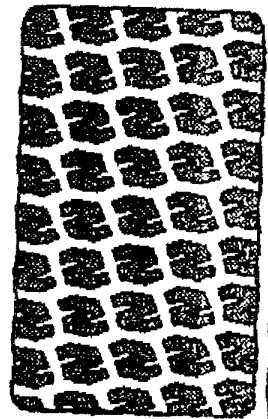
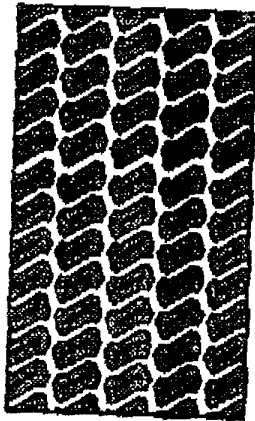
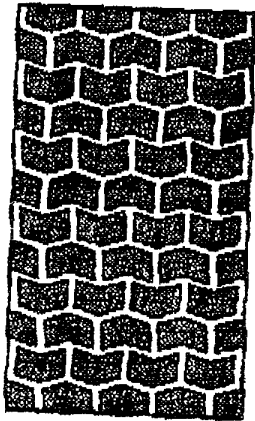
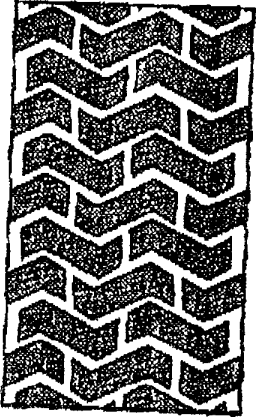

"A"

"B"

"C"

"D"

TIRE SIZE

	"A"	"B"	"C"	"D"
11 X 4.00 - 5	42295	319679		
13 X 5.00 - 6	41060	319680		
15 X 6.00 - 6	39830	316702	301140	313952
16 X 6.50 - 8	41081	319682		314539
18 X 8.50 - 8	319683	317400		
18 X 9.50 - 8	41106	316701		313950
20 X 8.00 - 8	319685	319684	57164	314584
20 X 10.00 - 8	58276	319686		313654
20 X 10.00 - 10	55893	319687		
23 X 9.50 - 12	53655	319690	319689	314370

ACCESSORIES

Contact the dealer where your tractor was purchased for the available accessories. If you are unable to contact the dealer, write to the address on the front cover of this manual.

Model	Description	Rear Engine Rider
5708-16	Bagger - Fits 32" Side Discharge	
5708-17	Bagger - Fits 36" Side Discharge & 30" Top Discharge	
5709-02	Front Weight Box - holds 35 lbs.	
5648-16	Lawn Sweeper w/dump Release	
5714-00	Mulching Kit - 30" Top Discharge	

Model	Description	Lawn Tractor
5708-22	Bagger - Fits 30" Side Discharge	
5708-13	Bagger - Fits 36", 38", 39" & 45" Side Discharge	
5705-04	36" Two-Stage Snowblower - Fits 36", 38", 39", & 45" Side Discharge	
5661-08	42" Snowblade - Fits 36", 38", 39", & 45"	
5592-00	Tire Chains - 18" x 8.50"	
5885-00	Tire Chains - 18" x 9.50" & 20" x 8"	
5672-01	Wheel Weights - Front - 1 pr. w/mtg. hdw. - Fits 15" tires	
5673-02	Wheel Weights - Rear - 1 pr. w/mtg. hdw. - Fits 18" & 20" tires	
5709-03	Front Weights - Fits 30" & 32" Side Discharge	
5648-16	Lawn Sweeper w/dump Release	
5714-00	Mulching Kit - 30" Top Discharge	

Model	Description	Garden Tractor - Light Ground Engaging
5708-13	Bagger - Fits 36", 38", 39", & 45" Side Discharge	
5705-04	36" Two-Stage Snowblower - Fits 36", 38", 39", & 45"	
5661-06	42" Snowblade - Fits 36", 38", 39", & 45"	
5672-01	Wheel Weights - Front 1 pr. w/mtg. hdw. - Fits 15" tires	
5673-02	Wheel Weights - Rear - 1 pr. w/mtg. hdw. - Fits 18" & 20" tires	
5648-16	Lawn Sweeper w/dump Release	
5687-02	Sleeve Hitch - w/lift bar - Fits 45"	
5668-01	Adaptor (sleeve hitch) for use w/23" tires	
5708-00	Tire Chains - 20" x 10"	
5671-00	Tire Chains - 23" x 9.50"	
5672-02	Wheel Weights - Front - 1 pr. w/mtg. hdw. Fits 16" tires	
5673-00	Wheel Weights - Rear - 1 pr. w/mtg. hdw. Fits 23" tires	
5674-01*	10" One Bottom Moldboard Plow	
5675-01*	Cultivator - 7 row - Adj. 6" - 42" width	
5676-01*	Disc Harrow - 8" & 11" Disc - Adj. width & disc angle	
5677-02*	Tiller - 5 H.P. Self-Powered - 28" width	

Model	Description	Four Wheel Steer
5708-14	Bagger - Fits 40" & 46" Side Discharge	
5705-05	42" One-Stage Snowblower - Fits 40" & 46"	
5661-07	48" Snowblade - Fits 40" & 46"	
5709-04	Rear Weight Box for 40" & 46"	
5648-16	Lawn Sweeper w/dump Release	
5706-00	Tire Chains 20" x 10"	
5671-00	Tire Chains 23" x 9.50"	
5672-02	Wheel Weights - Front - 1 pr. w/mtg. hdw. Fits 16" tires	
5673-00	Wheel Weights - Rear - 1 pr. w/mtg. hdw. Fits 23" tires	
5672-01	Wheel Weights - Front - 1 pr. w/mtg. hdw. Fits 15" tires	
5673-02	Wheel Weights - Rear - 1 pr. w/mtg. hdw. Fits 18" & 20" tires	

Model	Description	Two Wheel Steer Garden Tractor
5687-04	Sleeve Hitch - w/lift bar Fits 46"	
5674-01*	10" One Bottom Moldboard Plow	
5675-01*	Cultivator - 7 row - Adj. 6" - 42" width	
5676-01*	Disc Harrow 8" & 11" Disc - Adj. width & disc angle	
5677-02*	Tiller 5 H.P. Self-Powered - 28" width	
5648-16	Lawn Sweeper w/dump Release	

*Requires a sleeve hitch