

TRACTEUR DE PELOUSE MODÈLE D3560-330 (36 po)

CHASSIS & HOOD (FRONT) / CHÂSSIS & CAPOT (AVANT)

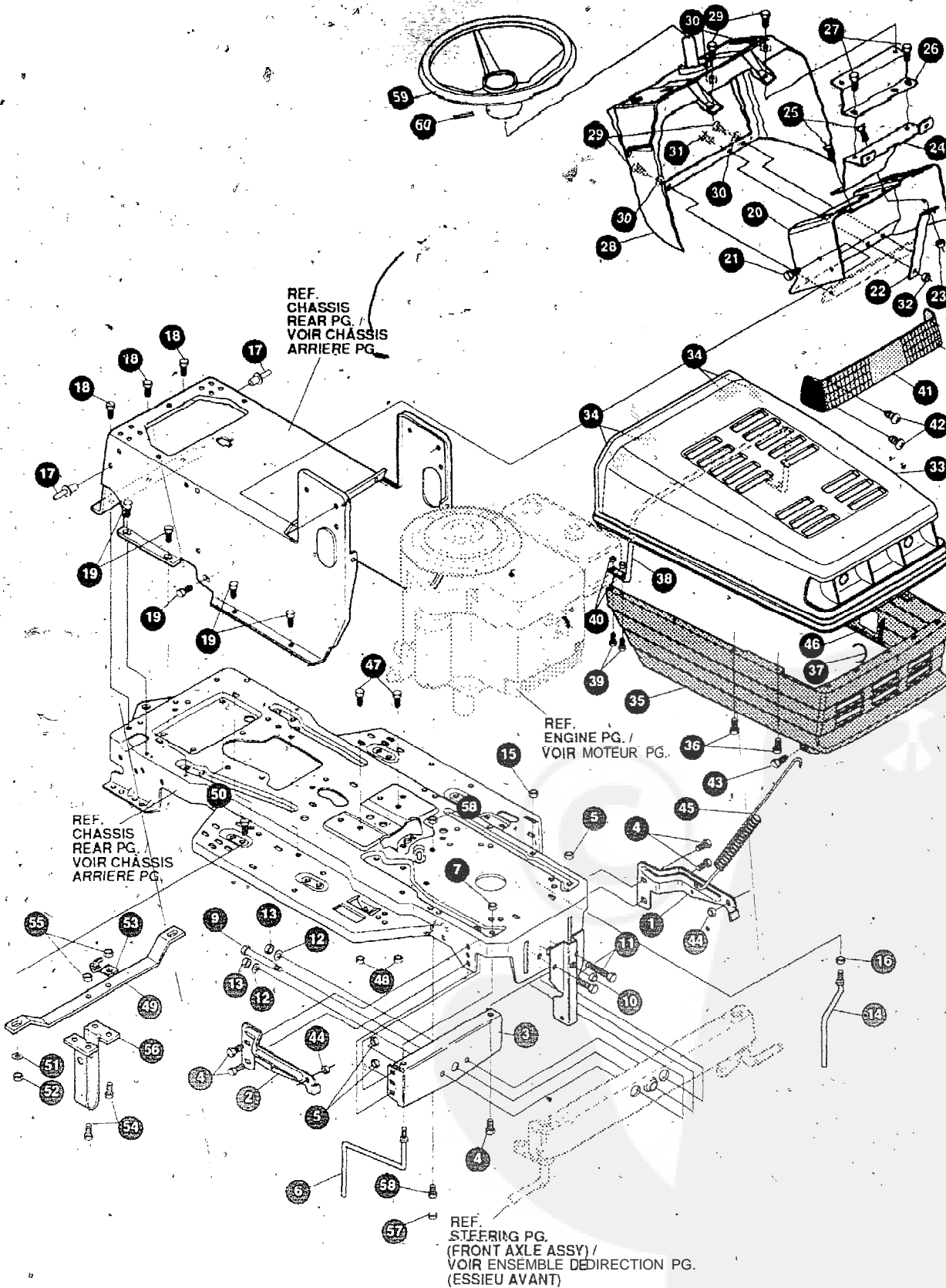

REMARQUE: UTILISEZ DES PIÈCES D'ORIGINE POUR C-ON-SERVER L'APPLICATION DE LA GARANTIE.

TOUTES LES PIÈCES NON REFERÉES SONT INTERCHANGES AVEC LEURS OPPOSEES.

329578A

TRACTEUR DE PELOUSE MODÈLE D3560-330 (36 po)

KEY#	PART#	DESCRIPTION	QTY.
1	326569-853	BRACKET,GRILLE LH	1
2	326568-853	BRACKET,GRILLE R H	1
3	313541-853	BRACKET, FRONT AXLE	1
4	56030,	S C R E W , 5/16-18X.75WDFLLK	5
5	55273	NUT, 5/16-18 HXWDFLLK	5
6	300440	GUIDE, BELT, RIDER	1
7	1498	NUT, 5/16-18 REGHEXCTRLK	1
8	57167-860	FRONT HANGER BRKT	1
9	308207	BOLT, .625X2.180 HSH 1/2-13NC	1
10	309008	NUT, 1/2-13REGHCTRLK	1
11	122207	SCREW, 3/8-16X3.00 HHC	2
12	2463	WASHER, .391DX1.25DX.07 BELLVIL	2
13	1499	NUT, 3/8-16 REGHCTRLK	2
14	300635	GUIDE,SHORT BELT RIDER 15"WH	1
15	124824	NUT, 5/16-18HEXJAM	1
is	271190	NUT, 3/8-16 HEXKEPS	1
17	46763	RIVET, POP .187DIAX.450	3
18	35497	SCREW, 5/16-18X.50 WAHTAP	2
19	995346	SCREW, 1/4-20X.50 WAHTAP	10
20	58312-853	SUPPORT, DASH	1
21	300303	SCREW, .25X.75X.75HHWAPLASTITE	2
22	300201-853	BRACE, DASH SUPT LOWER	1
23	1502	NUT, 1/4-20 REGHEXCTRLK	1
24	302530-853	BRKT, GAS TANK	1
25	995346	SCREW, 1/4-20X.50 WAHTAP	2
26	300264-853	BRACE, DASH SUPT UPPER	1
27	995346	SCREW, 1/4-20X.50 WAHTAP	2
28	305428	DASH,GP W/O GRAPHIC,SUS	1
29	995346	SCREW, 1/4-20X.50 WAHTAP	4
30	316868	WASHER,SHOULDER NYLON .255X.46	4
31	44811	SCREW, 1/4-20X.75 HXWATAP	1
32	1 5 0 2	NUT, 1/4-20 REGHEXCTRLK	1
33	307033	HOOD, H-11 PLASTIC	1
34	318197	PAD,ADHESIVE 1.00 X	4
35	303037	GRILL,LWR GPWR	1
36	300302	SCREW, #10 X .50 HHTAPPST	4
3	7 310203	CLIP,HOGRING C-SHAPED	1
38	301425	BRACE,HOOD SUPPORT	1
39	301542	SCREW, 10-24X1 .00HWATAPBLKPHOS	4
40	271166	NUT, #10-24HEXKEPS	4
41	302333	LENS. SMOKED WJTAB	1
42	57796	SCREW, #6 X .50 PLASTITE	4
43	56676	BOLT, .375X.580 HSH 5/16-18	2
44	1498	N U T , 5/16-18 REGHEXCTRLK	2
45	57478	SPRING, HOOD LATCH	2
46	301452	FOIL, HEAT REFLECTOR	1
47	186079	SCREW,5/16-18X1.00 HHC	2
48	1498	NUT,5/16-16 REGHEXCTRLK	2
49	4 3 9 6 4	SUPPORT STRAP, GUIDE	1
50	126216	CARRIAGE BOLT 5/16-18X.75	2
51	446363	WASHER, FLAT .375X.88X.082	2
52	1498.	NUT, 5/16-18 REGHEXCTRLK	2
5	3 57569	RETAINER	1
54	122017	S C R E W , 5/16-18X1.00 HHC	2
55	1498	NUT, 5/16-18 REGHEXCTRLK	2
56	49777	REAR DECK GUIDE	1
57	56599	UPSTOP BOLT 3/8-16x8.50	1
58	271190	NUT 3/8-16 HXKEPS	2
59	301251	STEERING WHEEL	1
60	456378	ROLL PIN	3
61	329919	PARTS MANUAL	1
62	329965	OPERATOR'S MANUAL (FRENCH)	1

TRACTEUR DE PELOUSE MODÈLE D3560-330 (36 po)

CHASSIS & HOOD (REAR) / CHÂSSIS & CAPOT (ARRIÈRE)

REF.
MOTION DRIVE PG. /
COMMANDE DE
PROV LSION PG.

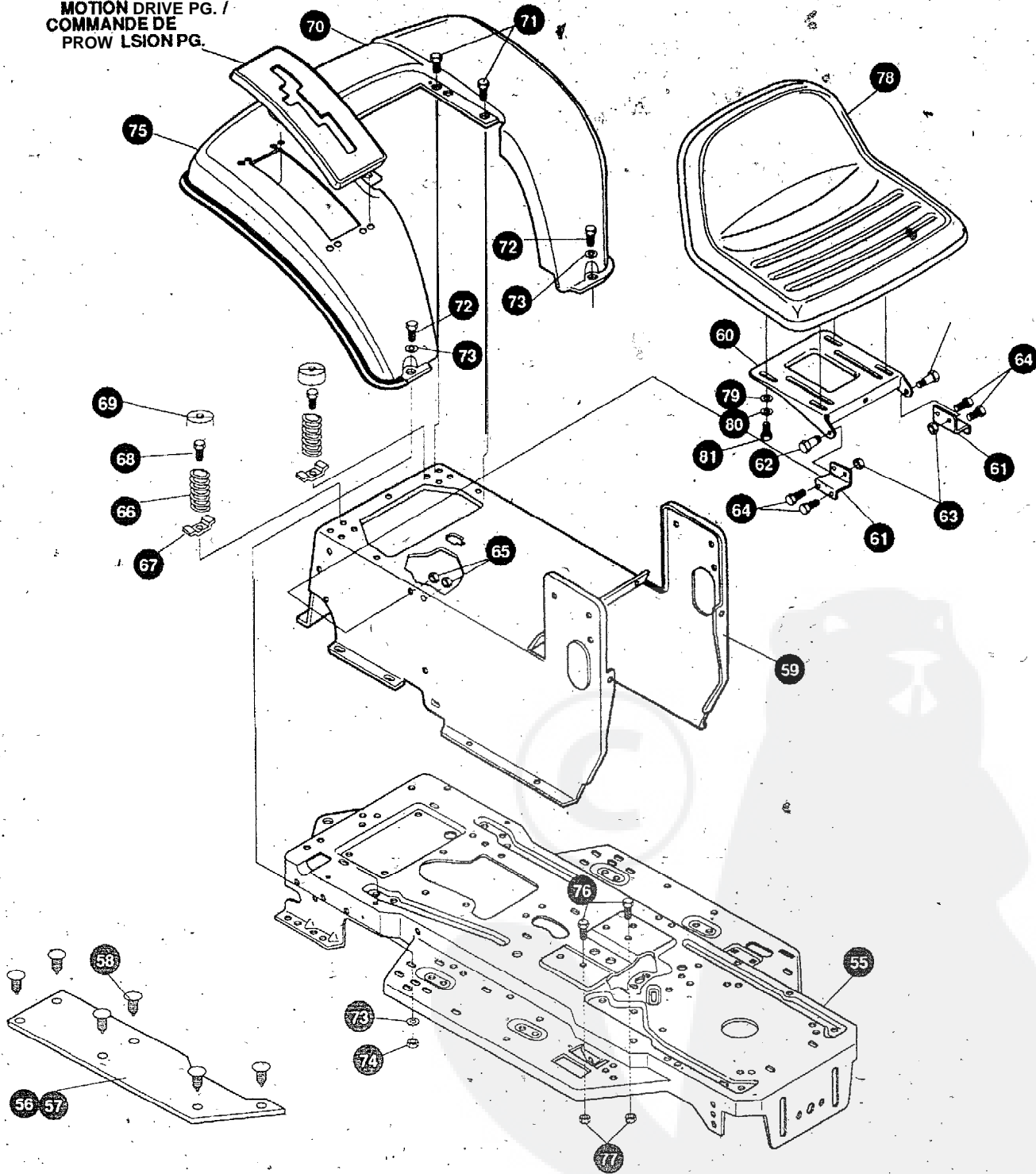

REMARQUE: UTILISEZ DES PIÈCES D'ORIGINE
POUR CONSERVER L'APPLICATION DE LA
GARANTIE.

TOUTES LES PIÈCES NON
REFERÉES SONT
INTERCHANGES AVEC
LEURS OPPOSEES.

3295798A

TRACTEUR DE PELOUSE MODÈLE D3560-330 (36 po)

KEY#	PART#	DESCRIPTION	QTY.
55	326577-860	FRAME, LF MAIN 930/4360	1
56	310005	FOOTPAD LH	1
57	310006	FOOTPAD RH	1
58	309235	FASTENER, RATCHET	12
59	327575-860	CONSOLE GNPR-SOF	1
60	58367-860	PLATE, SEAT	1
61	310660-860	BRACKET, F-5 SEAT SUPPORT	1
6 2	20507	BQLT, .437X .156 HSH 5/16-18	2
63	1 4 9 8	NUT, 5/16-18 REGHEXCTRLK	2
64	48901	SCREW, 5/16-18X .63 HHC	4
65	1498	NUT, 5/16-18 REGHEXCTRLK	4
66	5 7 1 5 3	SPRING, SEAT 2.63LG, 1.49OD	2
67	1341	CLAMP, SPRING 1.17"ID	2
68	44811	SCREW, 1/4-20X .75 HXWATAP	2
6 9	56907	COVER, SEAT SPRING 1.51DX1.0LG	2
70	308654-860	FENDER, ASM F5, GS, SOF	1
71	995346	SCREW, 1/4-20X .50 WAHTAP	4
72	122017	SCREW, 5/16-18X1.00 HMC	2
73	446363	WASHER, FLAT .375X .88X.082	4
74	1498	NUT, 5/16-18 REGHEXCTRLK	2
75	55023	TRIM, STRIP, BLACK	77.5IN
7 6	180079	SCREW, 5/16-18X1.00 HHC GR.5	2
77	1498	NUT, 5/16-18 REGHEXCTRLK	2
..... BOXED ITEMS			
78	304316	SEAT	1
79	120393	WASHER, FLAT .344X.69X.0 065	4
80	120638	WASHER, HVSPTLK	4
81	1 2 2 0 0 7	SCREW, 5/16-18X.75 HHC	4



TRACTEUR DE PELOUSE MODÈLE D3560-330 (36 po)

STEERING ASSEMBLY / ENSEMBLE DE DIRECTION

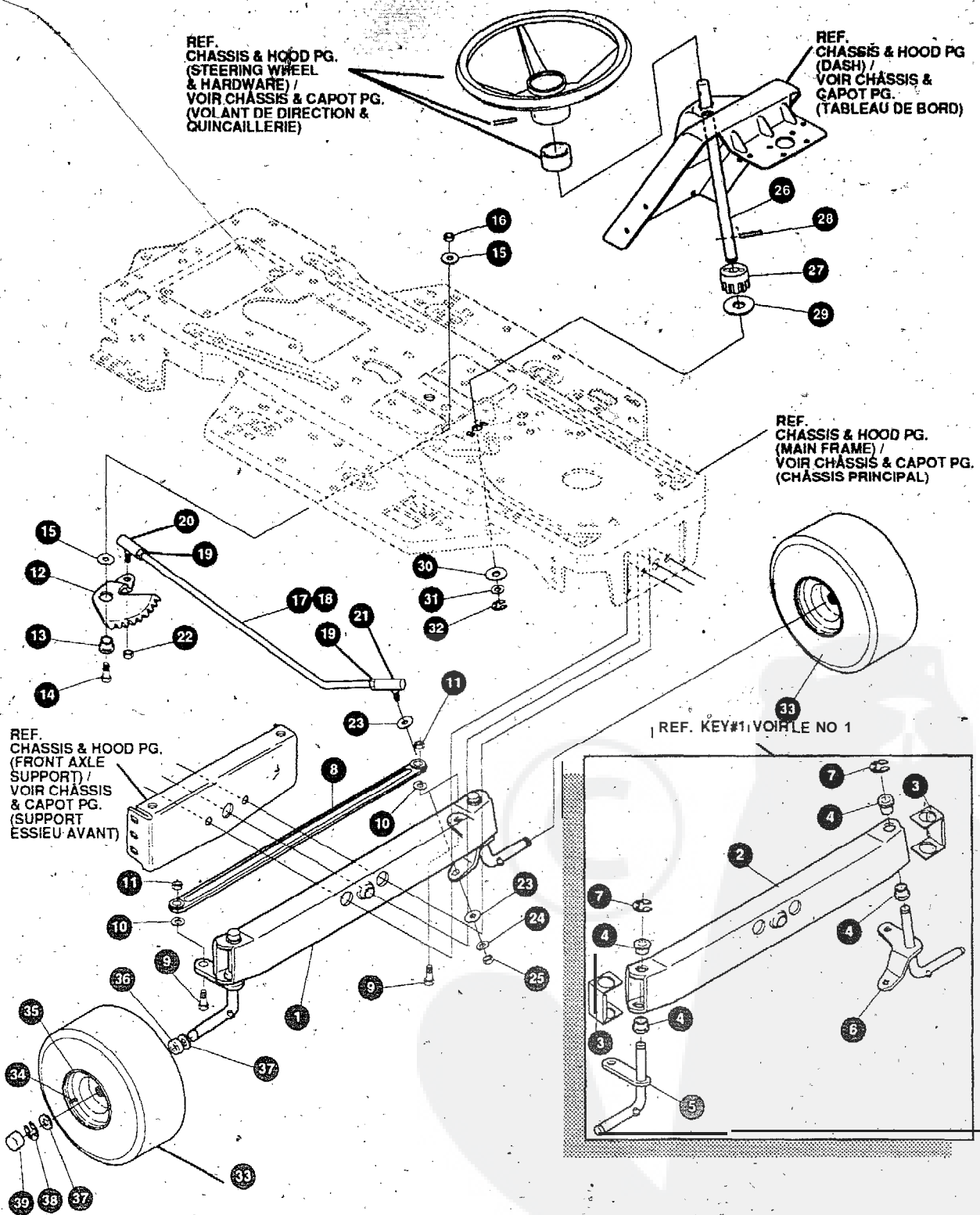

REMARQUE: UTILISEZ DES PIÈCES D'ORIGINE POUR CONSERVER L'APPLICATION DE LA GARANTIE.

TOUTES LES PIÈCES NON REFERÉES SONT INTERCHANGÉES AVEC LEURS OPPOSEES.

329568

TRACTEUR DE PELOUSE MODELE D3560-330 (36 po)

KEY#	PART#	DESCRIPTION	QTY.
1	A	ASSY, AXLE, FRONT GS	1
2	310170-860	AXLE, FRONT	1
3	53373-860	AXLE COVER	1
4	52407	SPINDLE BEARING	4
5	302926	ASSY, SPINDLE RH	1
6	315666	ASSY, SPINDLE LH	1
7	36625	RING, RETEX .57X.05TRU5133-75	2
8	304590	TIE: ROD ASSY 19.81LG W. SECTION	1
9	160128	SCREW, 3/8-16X1.75 HHC	2
10	120382	WASHER, REGSPTLK.393X.68X. 10	2
11	1499	NUT, 3/8-16 REGHEX	2
12	58289	SECTOR, STEERING LF	1
13	52406	BRNG, FL ECC.510IDX .998ODX .56	1
14	180177	SCREW, 1/2-13X1.50 HHC	1
15	22265	WASHER, FLAT .515X1.38X.119	2
16	1500	NUT, 1/2-13 REGHCTRLK	1
17	311100	DRAGLINK ASSY	1
18	58291	STEERING LINK	1
19	124925	NUT, 3/8-24 REGHEXJAM	2
20	5 7 1 5 8	BALL JOINT 3/8 THD SHORT STUD	1
21	21275	BALL JOINT 3/8 THD LONG STUD	1
22	46692	NUT, 3/8-24 WDFLHLK WHIZ	1
23	120396	WASHER, FIAT .531X1.06X.095	2
24	120382	WASHER, REGSPTLK.393X.68X. 10	1
25	120369	NUT, 3/8-24 REGHEX	1
26	58243	SHAFT, STEERING	1
27	58244	PINION, STEERING	1
28	56274	PIN, DOWEL .2500 OD+1.75LG	1
29	301410	BRNG, FL .752IDX1.061ODX .24	1
30	301398	WASHER, FORMED1.135X1.53X.12 --	1
31	21682	WASHER, FLAT.765X1.25X.042	1
32	36625	RING, RETEX .57X.05TRU5133-75	1
33	316702	TIRE & RIM, PU15X6.0X6 GENERIC	2
34	24167	VALVE STEM	1
35	39829	WHEEL W/BRG.	1
36	39979	BEARING, FL1.38OD+.753ID PM	2
37	642	WASHER, FLAT .755X1.31X.075	4
38	36625	-RING, RETEX .57X.05TRU5133-75	2
39	40394	CAP, 1.500IDX7/8LG HUB	2

*ORDER INDIVIDUAL PARTS.

TRACTEUR DE PELOUSE MODÈLE D3560-330 (36 po)

MOTION DRIVE / COMMANDE DE PROPULSION

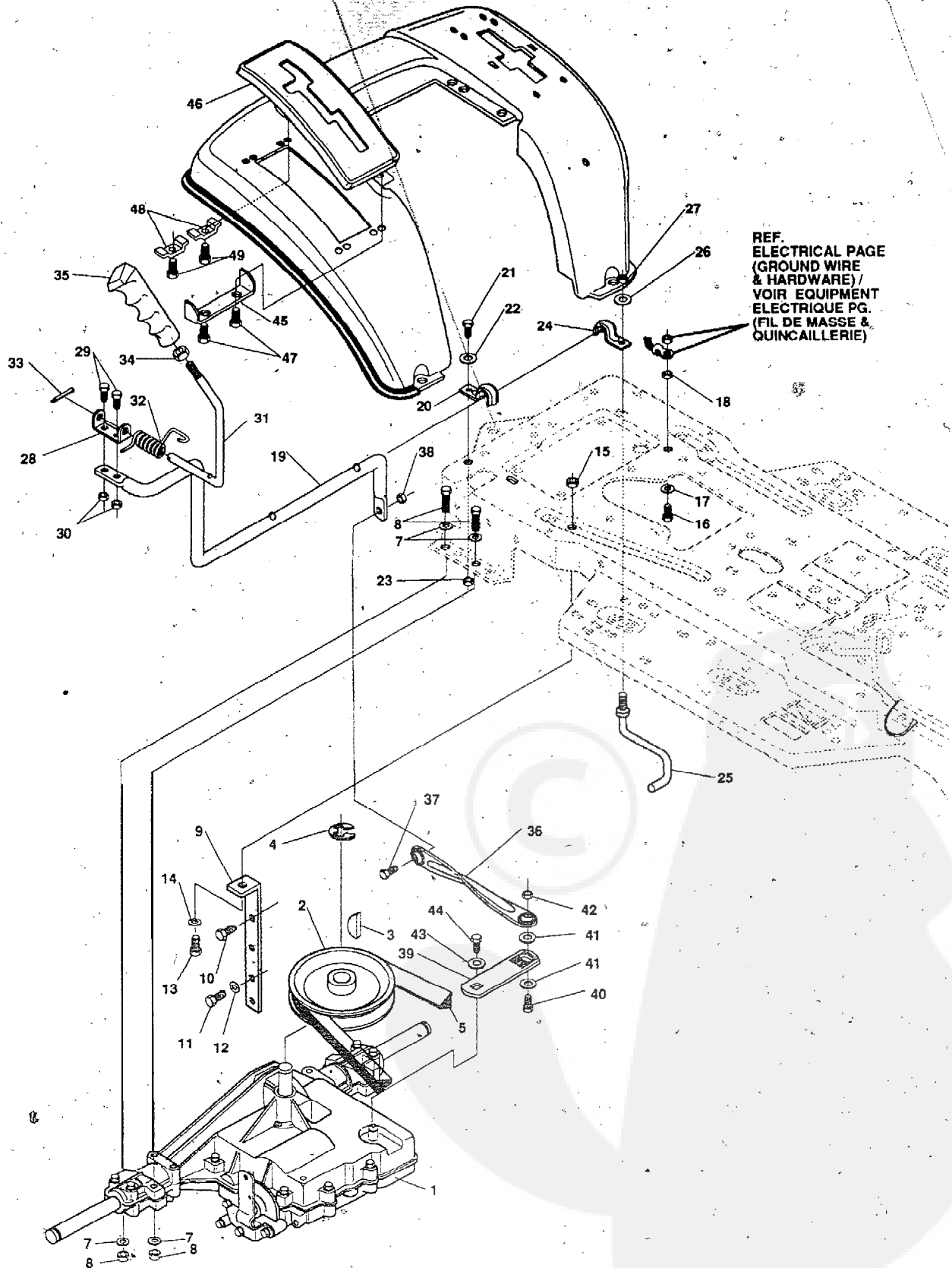

REF. ELECTRICAL PAGE (GROUND WIRE & HARDWARE) / VOIR EQUIPMENT ELECTRIQUE PG. (FIL DE MASSE & QUINCAILLERIE)

REMARQUE: UTILISEZ DES PIÈCES D'ORIGINE POUR CONSERVER L'APPLICATION DE LA GARANTIE.

TOUTES LES PIÈCES NON REFERÉES SONT INTERCHANGES AVEC LEURS OPPOSEES.

326895A

TRACTEUR DE PELOUSE MODÈLE D3560-330 (36 po)

KEY#	PART#	DESCRIPTION	QTY.
1	A	TRANSAXLE LF P930 EXT. BRAKE SHAFT	1
2	302745	PULLEY	1
3	3021	KEY, WDRF 606 .750X.187X.312	1
4	22053	RING, RETEX .58X.04TRU5100-62	1
5	314120	BELT	1
6	160089	SCREW, 5/16-18X2.25 HHC	4
7	120393	WASHER, FLAT .344X .69X.065	8
8	1498	NUT, 5/16-18 REGHEXCTRLK	4
9	323471	MF STABILIZER BRKT P920, F4150	1
10	50947	SCREW, 3/8-16X1.25 WAHTAP	1
11	35490	SCREW, 5/16-18X.75 WAHTAP	2
12	120638	WASHER, HVSP TLK .328X.60X.09	2
13	122017	SCREW, 5/16-18X1.00 HHC	1
14	120393	WASHER, FLAT .344X .69X.065	1
15	1498	NUT, 5/16-18 REGHEXCTRLK	1
16	122007	SCREW, 5/16-18X.75 HHC	1
17	138538	WASHER, REGINTLK.320X.61X.03	1
18	1 4 9 8	NUT, 5/16-18 REGHEXCTRLK	1
19	319111	LEVER, SHIFT, LWR 4360 LF	1
20	310347-853	CLIP-SHIFT LEVER .62 ROD	1
21	180077	SCREW, 5/16-18X.75 HHC	1
22	996416	WASHER, FLAT .391X1.00X.125	1
23	1 4 9 6	NUT, 5/16-18 REGHEXCTRLK	1
24	310347-853	CLIP-SHIFT LEVER .62 ROD	1
25	57259	GUIDE, BELT 5/16-18THD	1
26	996416	WASHER, FLAT .391X1.00X.125	1
27	1498	NUT, 5/16-18 REGHEXCTRLK	1
28	3 1 0 3 5 6	PIVOT BRKT LEVER	1
29	180018	SCREW, 1/4-20X.62 HHC	2
30	1502	NUT, 1/4-20 REGHEXCTRLK	2
3	1	LEVER, SHIFT UPPER SF 1/2-13TH	1
32	310265	SPRING, TORS. 56X.95X.095	1
3	3	PIN, COTTER .125 DIA X1.00 LG	1
34	120238	NUT, 1/2-13 HEXJAM	1
35	306690	HANDLE 1/2-13 MOLDED	1
36	314965	LINK TIE ROD SHIFTER P930-6LF	1
37	180124	SCREW, 3/8-16X1.25 HHC	1
38	1499	NUT, 3/8-16 REGHXCTRLK	1
39	309637	BRACKET, SHIFT 5SP SF FEN HT	1
40	180124	SCREW, 3/8-16X1.25 HHC	1
41	1 2 0 3 9 4	WASHER, FLAT .406X .81X.065	2
42	1499	NUT, 3/8-16 REGHXCTRLK	1
d3	57157	WASHER, .750X.250 SP-TRANSAXLE	1
44	56255	SCREW, 1/4-28X.75 NYLHHC	1
45	3 11257-853	BRACKET COVER	1
46	311209	COVER PLASTIC	1
47	311331	SCREW, 1/4-15X .44/.53 HILOHWA	2
4 8	1341	CLAMP SPRING	2
49	311331	SCREW, 1/4-15X .44/.53 HILOHWA	2

^ CONTACT YOUR NEAREST TRANSAXLE DEALER FOR PARTS AND SERVICE.

TRACTEUR DE PELOUSE MODÈLE D3560-330 (36 po)

MOTION DRIVE / COMMANDE DE PROPULSION

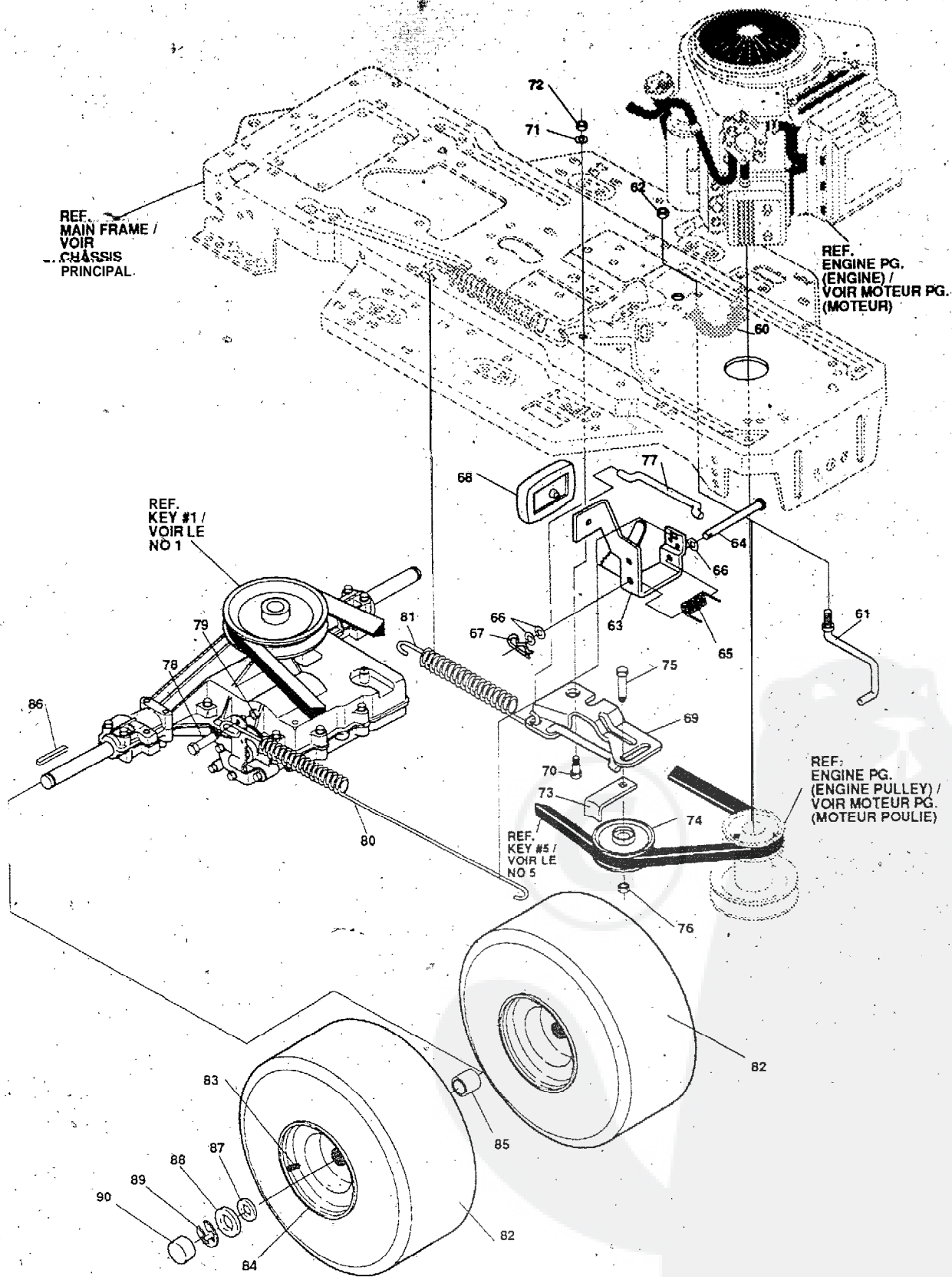

REMARQUE: UTILISEZ DES PIÈCES D'ORIGINE
POUR CONSERVER L'APPLICATION DE LA
GARANTIE.

TOUTES LES PIÈCES NON
REFERÉES SONT
INTERCHANGES AVEC
LEURS OPPOSEES.

326895/A

TRACTEUR DE PELOUSE MODÈLE D3560-330 (36 po)

KEY#	PART#	DESCRIPTION	QTY.
60	321514	SPRING BIAS DRAGLINK	1
6 1	304016	GUIDE BELT	1
62	1498	NUT, 5/16-18 REGHEXCTRLK	1
63	325942	PEDAL ASSY, BRAKE/CLUTCH LF	1
6 4	319675	PIN, CLEVIS	1
65	57847	SPRING, BRAKE PEDAL --	1
66	2968	WASHER, FLAT .504X .75X.059	3
67	56180	PIN, HAIR	1
68	48160	PAD, CLUTCH BRAKE W/PRINTING	1
69	320381853	ARM, IDLER TRACTION DR. LF,	1
70	300793	BOLT, .625X .135 HSH 5/16-18	1
71	45602	WASHER, FLAT .333X .87X.119	1
7 2	1498	NUT: 5/16-18 REGHEXCTRLK	1
73	39659	RETAINER, STRAP BELT	1
74	35374	PULLEY, IDLER V4L 3.06X .62	1
75	45392	BOLT, 3/8-16X1.50 CARR	1
76	1499	NUT, 3/8-16 REGHXCTRLK	1
77	57204	ROD, CLUTCH	1
78	326131	BOLT, .495X.31 HSH 5/16-18	1
79	1498	NUT, 5/16-18 REGHEXCTRLK	1
80	325937	SPRING BRAKE T1800, P930, F4360	1
81	56359	SPRING, CLUTCH .113X.750X8.75	1
82	319684	TIRE & RIM, PU 20X8-6 GENERIC	2
8 3	24167	VALVE-STEM	1
a4	301366	R I M , WHEEL 20X8.00	2
85	301565	S P A C E R	2
86	52928	KEY	2
8 7	642	WASHER, FIAT .755X1.31X.075	4
88	42815	WASHER, FLAT .755X1.53X.07	2
89	36625	RING, RETEX	2
90	40394	CAP, HUB	2

a

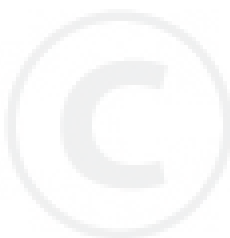

TRACTEUR DE PELOUSE MODÈLE D3560-330 (36 po)

ENGINE & CONTROL / MOTEUR ET COMMANDE

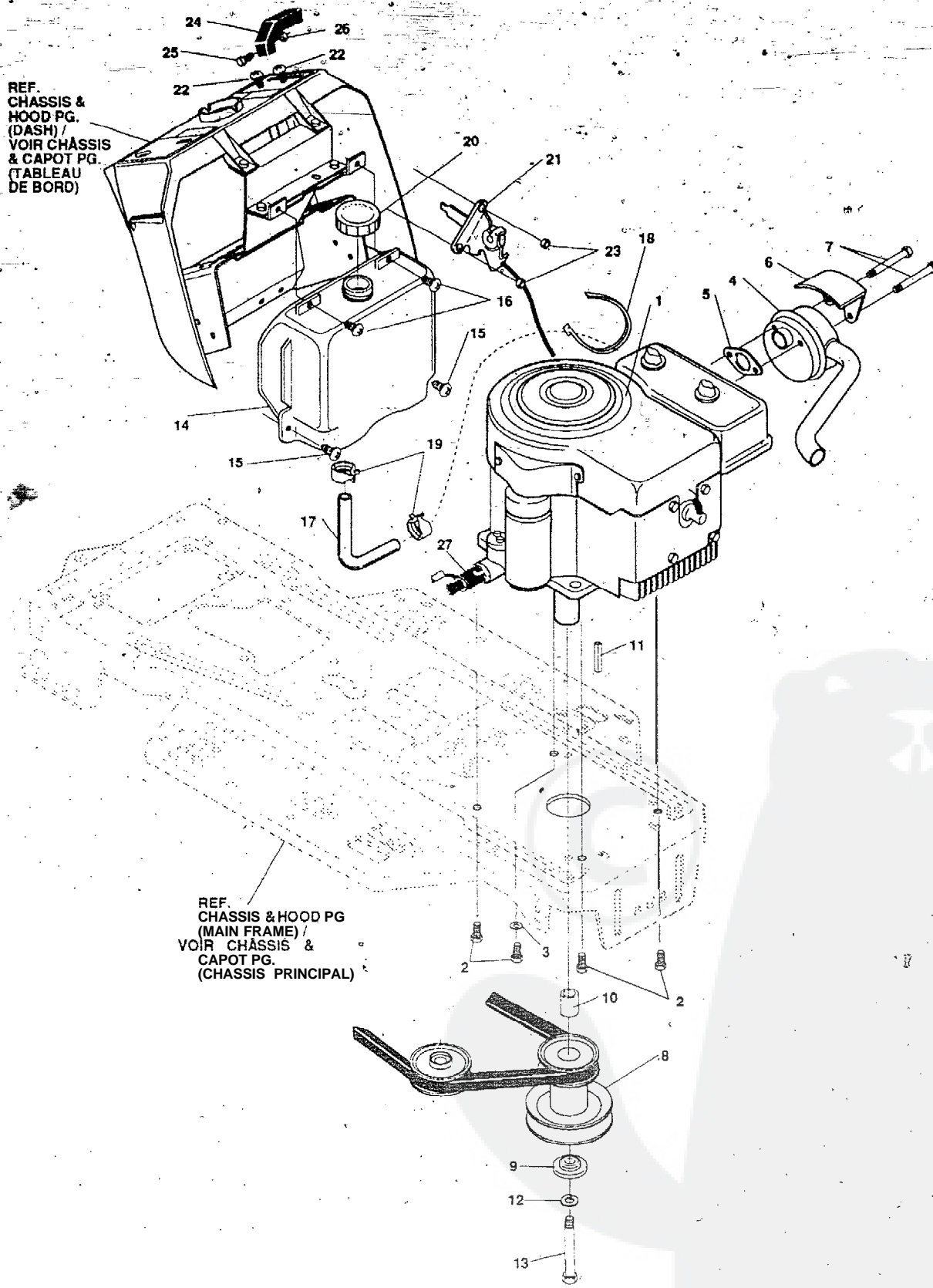

REMARQUE: UTILISEZ DES PIÈCES D'ORIGINE POUR CONSERVER L'APPLICATION DE LA GARANTIE.

TOUTES LES PIÈCES NOM
REFERÉES SONT
INTERCHANGES AVEC
LEURS OPPOSÉES.

329567 A

TRACTEUR DE PELOUSE MODÈLE D3560-330 (36 po)

KEY#	PART#	DESCRIPTION	QTY.
1	ENGINE	12 HP B&S 1/2 DUAL (SEE ENGINE MANUAL)	1
2	50947	SCREW, 3/8-16X1.25 WAHHTAP	4
3	138489	WASHER, EXLK 384X.69X.04	1
4	305367	MUFFLER-LO TONE-NELSON EXPORT	1
5	46708	GASKET, MUFFLER	1
6	54767	SHIELD, HEAT, FOR ROUND MUFFLER	1
	173063	SCREW, 5/16-18X3.50 HHC	2
8	313546	PULLEY ASSY, 4.75 OFFS 3/4 DIA 36' RD GEAR	1
9	56431	WASHER, .980 ID X 1.38 OD X .337 PILOT	1
10	304246	SPACER, SLEV 1.00 X 1.484	1
11	57791	KEY SQUARE .250 SQ. X 5.00 LG	1
12	120383	WASHER, REGSPTLK.459X.78X.12	1
13	428644	SCREW, 7/16-20X5.00 HHC	1
14	314991	TANK, FUEL 2-GAL.	1
15	300303	SCREW, .25X.75X.75HHWAPLASTITE	2
16	995346	SCREW, 1/4-20X.50 WAHHTAP	2
17	50118	GAS LINE .25ID	14'
18	57444	WIRE TIE	1
19	47345	CLAMP, FUEL LINE	2
20	300304	CAP, FUEL - 2.0 THROAT	1
21	303159	THROTTLE, CONTROL	1
2 2	320553	SCREW, 10-24X .63PHPNMA	2
23	271166	NUT, #10-24 HEXKEPS	2
24	300508	KNOB, THROTTLE CONTROL HANDGRIP	1
2 5	159585	SCREW, #8-32 X .38 PHPNMA	1
26	120622	NUT, #8-32 REGHX	1
27	325547	OIL DRAIN ITW	1



TRACTEUR DE PELOUSE MODÈLE D3560-330 (36 po)

PRE-PAINTED DECK ASSEMBLY / BOÎTIER DE TONDEUSES PEINT

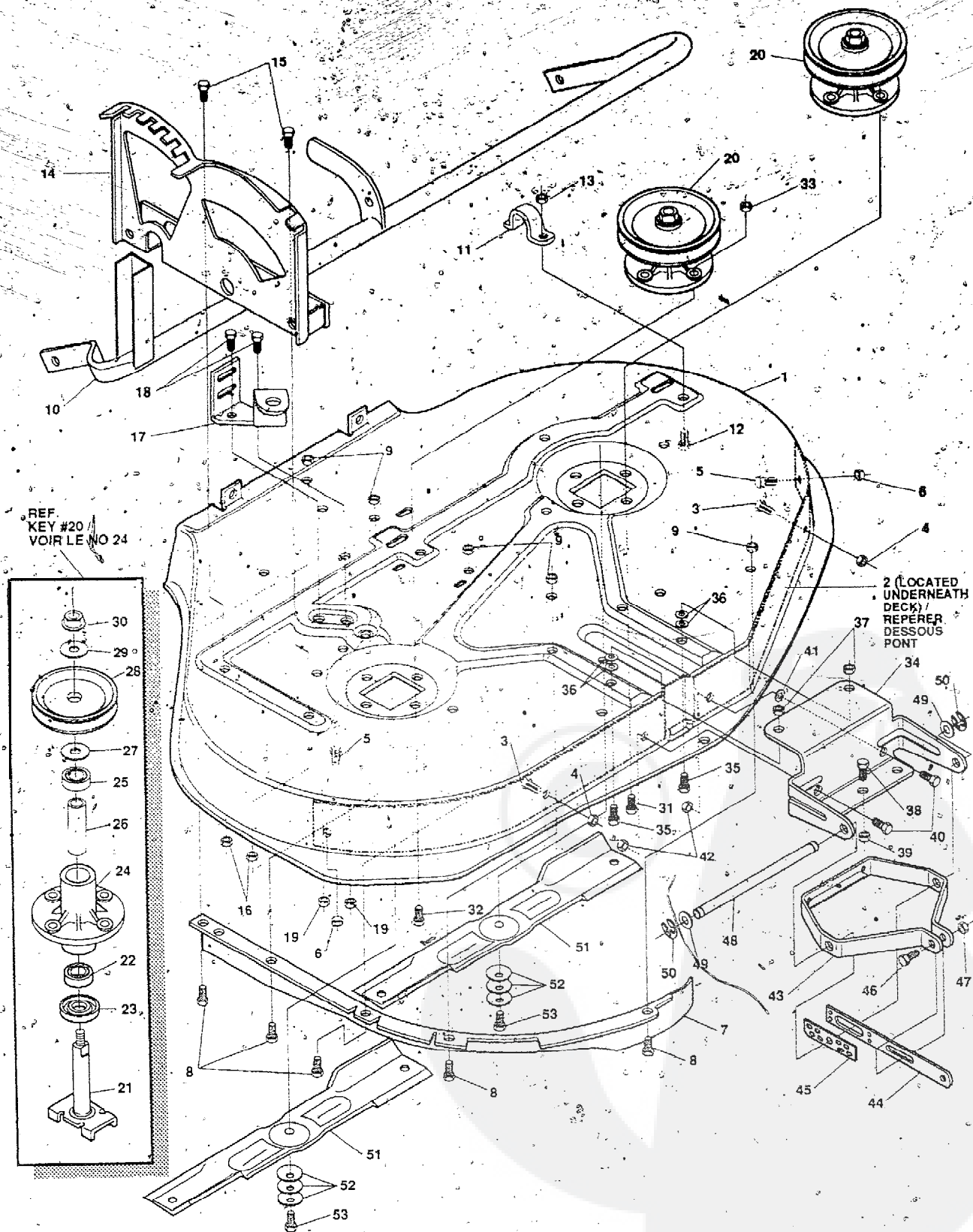

REF. KEY #20 / VOIR LE NO 24

2 (LOCATED UNDERNEATH DECK) / REPERER DESSOUS PONT

REMARQUE: UTILISEZ DES PIÈCES D'ORIGINE POUR CONSERVER L'APPLICATION DE LA GARANTIE.

TOUTES LES PIÈCES NON REFERÉES SON-ILS INTERCHANGÉS AVEC LEURS OPPOSÉS.

305462E

TRACTEUR DE PELOUSE MODÈLE D3560-330 (36 po)

KEY#	PART#	DESCRIPTION	QTY.
1	325094-853	DECK, 36RD STAMP DRILLED	1
2	312222	BAFFLE, 36RD DECK	1
		Note: BAFFLE LOCATED UNDERNEATH DECK	
3	180075	SCREW, 5/16-18X .63 HHC	2
4	1'498	NUT, 5/16-18 REGHEXCTRLK	2
120854		SCREW, 1/4-20X .63 HHC	2
6	1502	NUT, 1/4-20 REGHEXCTRLK	2
		BAFFLE, 36RD LH DECK	1
8	3-180075	SCREW, 5/16-18X .63 HHC	5
9	1498	NUT, 5/16-18 REGHEXCTRLK	5
10	304015	ASSY TORQUE TUBE 36"	1
11	310672	MS/MP SUPPORT, PIVOT TUBE	1
12	180075	SCREW, 5/16-18X .63 HHC	1
13	1498	NUT, 5/16-18 REGHEXCTRLK	1
14	313630	QUADRANT	1
15	180073	SCREW, 5/16-18X .50 HHC	2
16	1498	NUT, 5/16-18 REGHEXCTRLK	2
17	313631	BRACKET, IDLER	1
18	180075	SCREW, 5/16-18X .63 HHC	2
19	1498	NUT, 5/16-18 REGHEXCTRLK	2
20	56324-853	QUILL ASSY.	2
21	56425	SHAFT/SADDLE	1
22	49562	BRNG, BALL	1
23	50616	DUST SHIELD	1
24	55547	QUILL CASTING	1
25	49562	BRNG, BALL	1
26	5 0 8 1 8	SPACER, 3.797LGX.669IDX.88OD	1
27	51449	SPACER, 438LGX.932ODX.672ID	1
28	313898	PULLEY, 26/36" QUILL	1
29	5 6 3 6 5	SPECIAL WASHER	1
30	1282	NUT, 7/16-20 WDFLLK	1
31	50634	SCREW, 5/16-18X.88 WAHTAP	7
32	300345	SCREW, 5/16-18X1.38 WATAP	1
33	498	NUT, 5/16-18 REGHEXCTRLK	1
34	310762	LIFT PLATE	1
35	122007	SCREW, 5/16-18X.75 HHC	2
36	996416	WASHER, FLAT .391 X1.00X.125	4
37	1498	NUT, 5/16-18 REGHEXCTRLK	2
38	180075	SCREW, 5/16-18X .63 HHC	1
39	1498	NUT, 5/16-18 REGHEXCTRLK	1
40	122017	SCREW, 5/16-18X1.00 HHC	2
41	996416	WASHER, FLAT .391X1.00X.125	1
42	1496	NUT, 5/16-18 REGHEXCTRLK	2
43	310673	BRACKET, PIVOT	1
44	310230	B A R , HITCH	1
45	330229	BRACKET, LOCK	1
46	120918	SCREW, 3/8-16X1.50HHC	1
47	1499	NUT, 3/8-16 REGHXCTRLK	1
48	55724	PIN, PIVOT ROD .50DX7.55	1
49	996425	WASHER, FLAT .515X.88X.064	2
50	20864	RING, RETEX .39X.04	2
51	8685	BLADE, .36" STD-LIFT 1 8	2
52	2483	WASHER, .39IDX1.25DX.07 BELLVIL	6
53	39573	SCREW, 3/8-24X1.00 NYLHHC	2

TRACTEUR DE PELOUSE MODÈLE D3560-330 (36 po)

FINAL DECK ASSEMBLY / BOÎTIER DE TONDEUSES

R E F
PRE-PAINTED
DECK ASSY PO.
(IDLER BRACKET) /
VOIR BOÎTIER DE
TONDEUSES PG.
(BRAS D'TENSION)

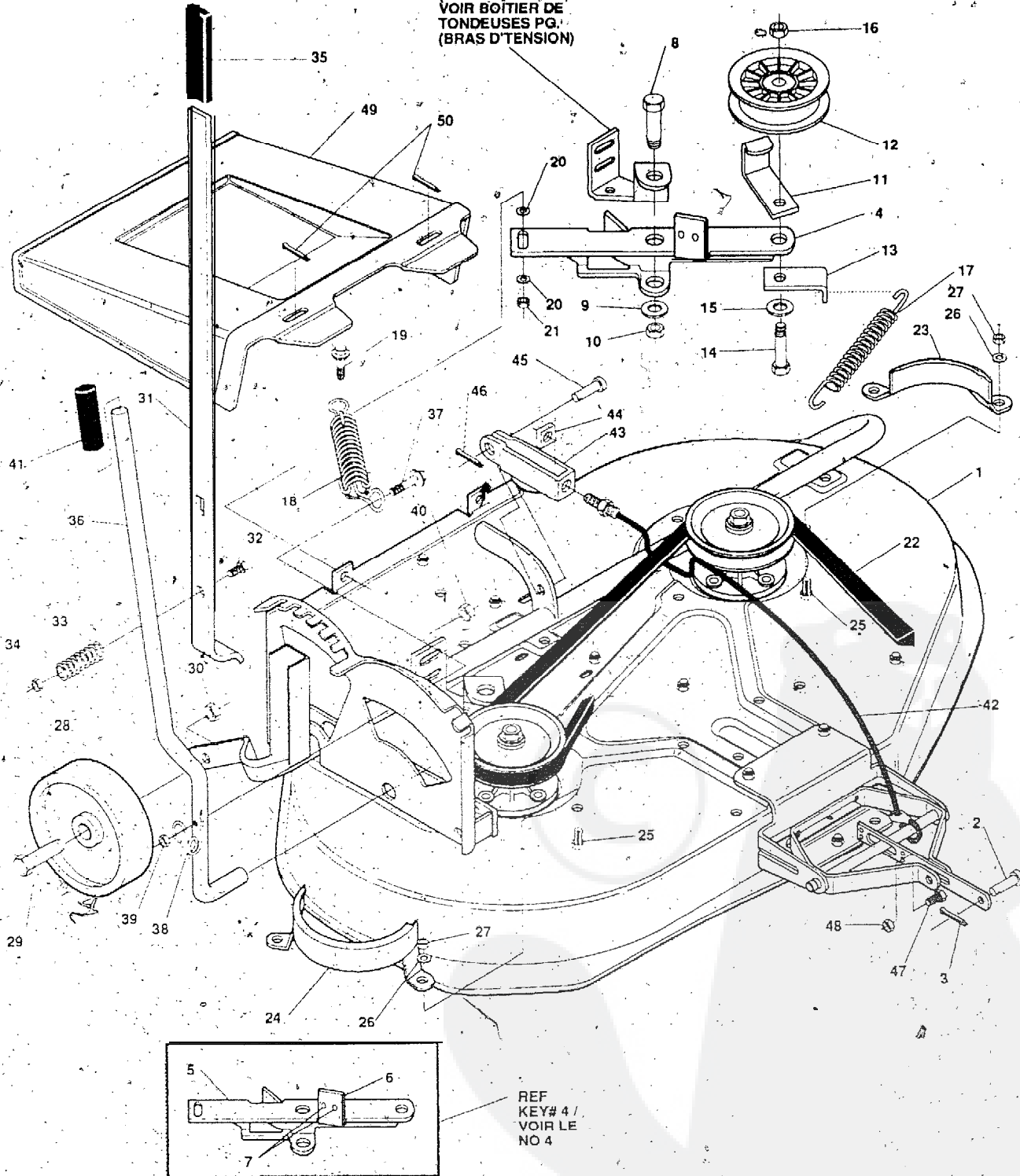

REF
KEY# 4 /
VOIR LE
NO 4

RÉMARQUE: UTILISEZ DES PIÈCES D'ORIGINE
POUR CONSERVER L'APPLICATION DE LA
GARANTIE.

TOUTES LES PIÈCES NON
REFERÉES SONT
INTERCHANGES AVEC
LEURS OPPOSÉES.

305460H

TRACTEUR DE PELOUSE MODÈLE D3560-330 (36 po)

KEY#	PART#	DESCRIPTION	QTY.
1	^	PAINTED DECK ASSEMBLY.	1
2	47817	PIN; .495X1.750 CLEVIS-SHORT	1
3	56160	PIN, HAIR .091 DIA X 1.62LG	1
4	311427	IDLER, ASSY PIVOT ARM	1
5	311426	PIVOT ARM IDLER BLK	1
6	306973	BRAKE PAD - HARD - 232AF	1
7	41601	RIVET, OVSET .187 DIA X .50LG	2
8	47516	-BOLT, .500X1.950 HHSH 3/8-16	1
9	996416	WASHER, FLAT .391X1.00X.125	1
10	1 4 9 9	NUT, 3/8-16 REGHXCTRLK	1
11	7354	RETAINER BELT	1
12	303028	PULLEY, IDLER BFF 3.13 DIA	1
13	57217-853	BRACKET, L-SHAPED	1
14	122168	SCREW, 3/8-16X1.75 HHC	1
15	446363	WASHER, FLAT .375X.66X.082	1
16	1499	NUT, 3/8-16 REGHXCTRLK	1
17	35410	SPRING .071 X .62X 4.37	1
18	52636	SPRING	1
19	46563	BOLT, .375X.250 SHWA 1/4-20	1
20	120392	WASHER, FLAT .281X.63X.065	2
21	1502	-NUT, 1/4-20 REGHEXCTRLK	1
22	308701	BELT; V 5L 80.00 DECK 36RD EXP	1
23	46365-853	COVER QUILL LH	1
24	46364-853	COVER, QUILL RH	1
25	180075	S C R E W , 5/16-18X1.00 HHC	4
2 6	120393	WASHER, FLAT .344X.69X.065	4
27	1 4 9 6	NUT; 5/16-18 REGHEXCTRLK	4
28	5 2 5 8 4	WHEEL, SD 6.00ODX1.38WD	2
29	23763	BOLT, .500X1.390 HHSH 3/8-16	2
30	1 4 9 9	NUT, 3/8-16 REGHXCTRLK	2
3 1	367050	LEVER HEIGHT ADJ	1
32	120696	SCREW, 5/16-18X2.25 HHC	1
33	53246	SPRING	1
34	1 4 9 8	NUT, 5/16-18 REGHEXCTRLK.	1
3 5	20250	GRIP, HAND .75X4.87	1
36	313632	LEVER, BLADE ENGAGE 32RD&36RD	1
37	1289	BOLT, .375X .250 SHWA 1/4-20	1
33	46561	SPRING, TORSION 36RD, 32RD	1
39	1502	NUT, 1/4-20 REGHEXCTRLK	1
40	53697	NUT, 1/2 PUSHON	1
41	4 6 4 7 8	GRIP, HAND .50ID 3.37LG BLK	1
42	325007	CABLE, LIFT 21.70 F-5 20X8-8	1
43	9405	CLEVIS, LIFT CABLE	1
44	120372	NUT, 1/4-20 REGSQ	1
45	3 9 5 2 2	PIN CLEVIS .312 X .812	1
46	56180	PIN, HAIR .091 DIA X 1.62LG	1
47	180075	SCREW, 5/16-18X.63 HHC	1
48	1 4 9 6	-NUT, 5/16-18 REGHEXCTRLK	1
49	50993	CHUTE EXTENSION PLASTIC 36"RD	1
50	120123	PIN. COTTER .125 DIA X 1.25LG	2

^ ORDER DECK KIT #13534 FOR COMPLETE DECK.

TRACTEUR DE PELOUSE MODÈLE D3560-330 (36 po)

ELECTRICAL / EQUIPMENT ÉLECTRIQUE

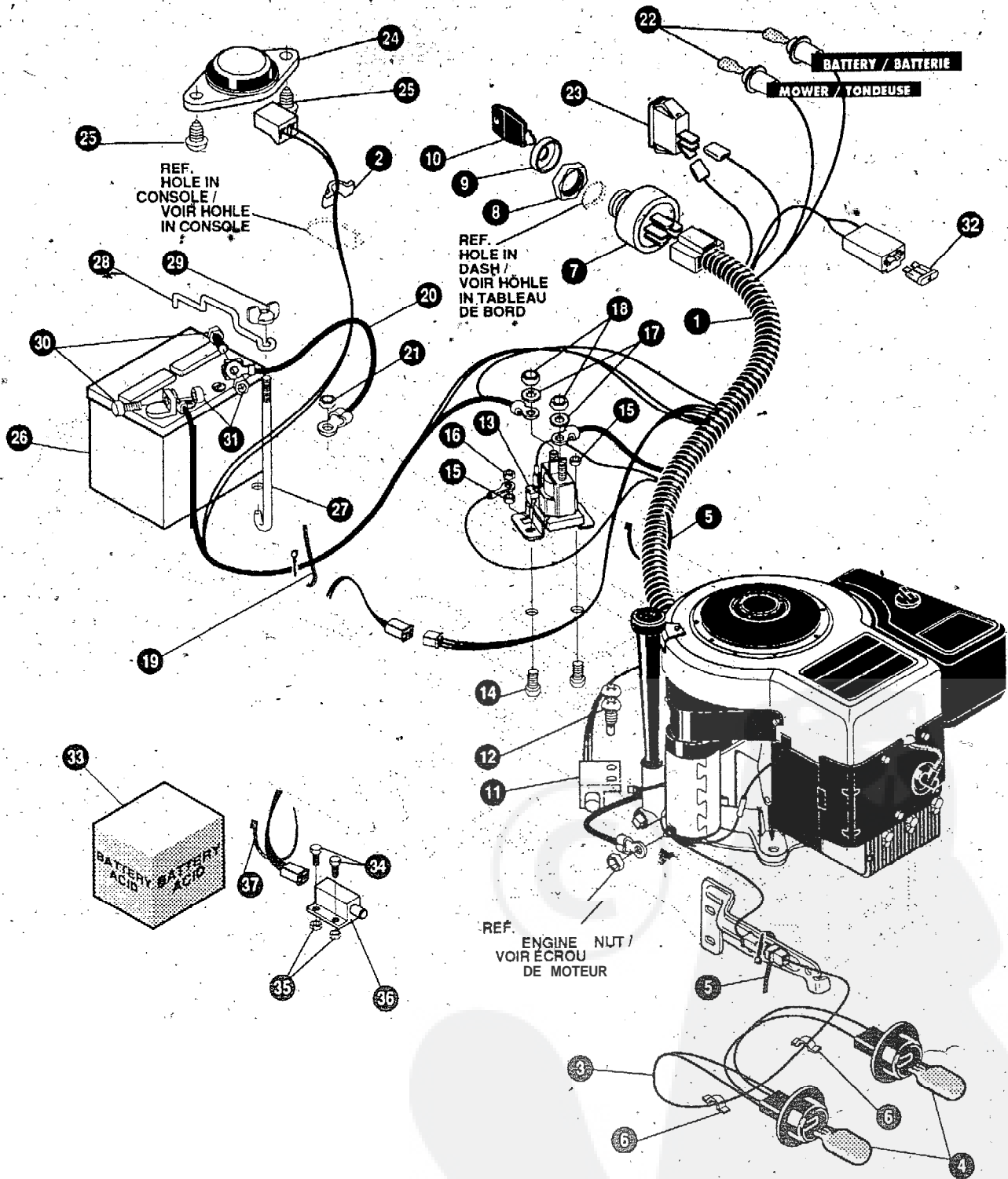

REMARQUE: UTILISEZ DES PIÈCES D'ORIGINE POUR CONSERVER L'APPLICATION DE LA GARANTIE.

TOUTES LES PIÈCES NON REFERÉES SONT INTERCHANGES AVEC LEURS OPPOSÉES.

329539A

TRACTEUR DE PELOUSE MODÈLE D3560-330 (36 po)

KEY#	PART#	DESCRIPTION	QTY.
1.	329552	HARNESS 12-12.5 H11G14 WRAP, LF	1
2.	41482	PRESS CLIP, 1.380LG, 255ID	1
3.	303064	ASSY, LIGHT WIRE-1/4 TURN	1
4.	52572	BULB, HEADLAMP	2
5.	57444	TIE, CABLE BLACK NYLON 5.62L	2
6.	41482	PRESS CLIP, 1.380LG, 255ID	2
	327355	SWITCH-IGN.(AFTER FIRE) 3 POSN	2
3	327352	NUT, 5/8-32 ACC #125 PLAST BLK	1
9:	300194	BOOT, IGN SWITCH	1
10.	327350	KEY, IGNITION SWITCH	1
11.	57476	SWITCH, SCR MNT DP NC NO BLK	1
12.	57220	SCREW, #12 X .50 PHPNHTAP, BLK	1
13.	53716	SOLENOID	2
14.	187745	SCREW, 1/4-20X.75 HXSEMMA	2
15.	1502	NUT, 1/4-20 REGHEXCTR LK	2
16.	271172	NUT, 1/4-20 REGHEXKEPS	2
17.	138485	WASHER, EXLK. 320X.61X.03	2
18.	120368	NUT, 5/16-24 REGHEX	2
19.	57444	TIE, CABLE BLACK NYLON 5.62L	2
20.	55511	WIRE, GROUND, 12.5	1
21.	271184	NUT, 5/16-18 HEXKEPS	1
22.	57769	BULB, INDICATOR	1
23.	300334	LIGHT SWITCH ON/OFF PANEL MNT	1
24.	57547	SWITCH, SEAT	1
25.	160505	SCREW 1/4-20X .38PHPNHMAGR2	1
26.	302257	BATTERY 12V 7 PLATE	2
27.	57551	ROD, BATTERY	1
28.	57552	ROD, BATTERY, TOP	1
29.	325232	NUT, WING 1/4-20 NYLON	1
30.	120854	SCREW, 1/4-20X.63 HHC GR2	1
31.	271172	NUT, 1/4-20 REGHEXKEPS	2
32.	30203 1	FUSE, 15 AMP SPADE TYPE	2
33.	^	BATTERY ACID, 80 OZ.	1
34.	155943	SCREW, #10-24X.63 PHPNMA	1
35.	271166	NUT, #10-24 HEXKEPS	2
36.	57476	SWITCH DP NO/NC SCR. MOUNT	2
37.	57444	TIE CABLE	1

^ CAN BE PURCHASED LOCALLY.
 .. SPADE TYPE FUSES ARE INCLUDED WITH THE WIRE HARNESS.

SCHEMATIC DRAWING / SCHEMA DE CÂBLAGE

