

PARTS MANUAL

Lawn Tractor



Model E3554-110

333311A

12-30-93

Price \$5.0



SAFETY RULES

THESE INSTRUCTIONS ARE FOR YOUR PROTECTION. PLEASE READ THEM CAREFULLY.

IMPORTANT

THIS CUTTING MACHINE IS CAPABLE OF AMPUTATING HANDS AND FEET AND THROWING OBJECTS. FAILURE TO OBSERVE THE FOLLOWING SAFETY INSTRUCTIONS COULD RESULT IN SERIOUS INJURY OR DEATH.

I. GENERAL OPERATION:

- Know controls and how to stop quickly.
- Read, understand, and follow all instructions in the manual and on the machine before starting.
- Only allow responsible adults, who are familiar with instructions, to operate the machine.
- Wear safety glasses or eye shields when assembling or operating the machine.
- Do not operate machine when barefooted. Always wear substantial footwear, preferably steel-toed shoes.
- Do not wear loose fitting clothing that could get caught in moving parts.
- Clear the area of objects such as rocks, toys, wire, etc., which could be picked up and thrown by the blade(s).
- Be sure the area is clear of other people before mowing. Stop machine if anyone enters the area.
- Never carry passengers.
- Do not mow in reverse unless absolutely necessary. Always look down and behind before and while backing.
- Be aware of the mower discharge direction and do not point it at anyone. Do not operate the mower without either the entire grass catcher or the guard in place.
- Slow down before turning.
- Never leave a running machine unattended. Always turn off blades, set parking brake, stop engine, and remove keys before dismantling.
- Turn off blade(s) when not mowing.
- Stop engine before removing grass catcher or unclogging chute.
- Mow only in daylight or good artificial light.
- Do not operate the machine while under the influence of alcohol or drugs.
- Watch for traffic when operating near or crossing roadways.
- Use care when mowing around a fixed object to prevent the blade(s) from striking it. Never deliberately run over any foreign object.
- Use extra care when loading or unloading the machine into a trailer or truck.
- Use care when pulling loads or using heavy equipment.
 - a. Use only approved drawbar hitch points.
 - b. Limit loads to those that you can safely control.
 - c. Do not turn sharply. Use care when backing.
 - d. Use counterweight(s), wheel weight or tire chains when suggested in attachment(s) instructions.

II. SLOPE OPERATION:

Slopes are a major factor related to loss-of-control and tip-over accidents, which can result in severe injury or death. *All slopes require extra caution.* If you cannot back up the slope or if you feel uneasy on it, do not mow it.

DO

- Mow up and down slopes, not across.
- Remove obstacles such as rocks, tree limbs, etc.
- Watch for holes, ruts, or bumps. Uneven terrain could overturn the machine. *Tall grass can hide obstacles.*
- Use slow speed. Choose a low gear so that you will not have to stop or shift while on the slope.
- Follow the manufacturer's recommendations for wheel weights or counterweights to improve stability.
- Use extra care with grass catchers or other attachments. These can change the stability of the machine.
- Keep all movement on the slopes *slow* and *gradual*. Do not make sudden changes in speed or direction.
- Avoid starting or stopping on a slope. If tires lose traction, turn off the blade(s) and proceed slowly *straight* down the slope.

DO NOT

- Do not turn on slopes unless necessary, and then slowly and gradually downhill, if possible.
- Do not mow near drop-offs, ditches or embankments. The

mower could suddenly turn over if a wheel is over the edge of a cliff or ditch, or if an edge caves in.

- Do not mow on wet grass. Reduced traction could cause sliding.
- Do not try to stabilize the machine by putting your foot on the ground.
- Do not use grass catcher on steep slopes.

III. CHILDREN:

Tragic accidents can occur if the operator is not alert to the presence of children. Children are often attracted to the machine and the mowing activity. *Never* assume that children will remain where you last saw them.

- Keep children out of the mowing area and under the watchful care of another responsible adult.
- Be alert and turn machine off if children enter the area.
- Before and when backing, look behind and *down* for small children.
- Never carry children. They may fall off and be seriously injured or interfere with safe machine operation.
- Never allow children to operate the machine.
- Use extra care when approaching blind corners, shrubs, trees, or other objects that may obscure vision.

IV. SERVICE:

- Use extra care in handling gasoline and other fuels. They are flammable and vapors are explosive.
 - a. Use only an approved container.
 - b. Never remove gas cap or add fuel with the engine running. Allow engine to cool before refueling. Do not smoke.
 - c. Never refuel the machine indoors.
 - d. Never store the machine or fuel container inside where there is an open flame, such as in a water heater.
- Check fuel supply before each use allowing space for expansion as the heat of the engine and/or sun can cause gasoline to expand and overflow the tank.
- Use extra care when handling battery acid. Acid contact with skin may cause severe burns. Eye contact may cause blindness.
- Use extra care when servicing the battery. Explosive gas is produced in the battery. Do not service the battery while smoking or near an open spark or flame. This may cause the battery to explode causing serious injury.
- Never run a machine inside a closed area. Exhaust fumes contain CARBON MONOXIDE, an ODORLESS and DEADLY GAS.
- Keep nuts and bolts, especially blade attachment bolts, tight and keep equipment in good condition.
- Never tamper with safety devices. Check their operation regularly.
- Do not change the engine governor settings or overspeed engine.
- Reduce fire hazards. Keep machine free of grass, leaves, or other debris build-up. Clean up oil or fuel spillage. Allow machine to cool before storing.
- Stop and inspect the equipment if you strike an object. Repair, if necessary, before restarting.
- Never make adjustments or repairs with the engine running.
- Grass catcher components are subject to wear, damage, and deterioration, which could expose moving parts or allow objects to be thrown. Frequently check components and replace with manufacturer's recommended parts, when necessary.
- Mower blade(s) are sharp and can cut. Wrap the blade(s) or wear gloves, and use extra caution when servicing them.
- Check brake operation frequently. Adjust and service as required.



LOOK FOR THIS SYMBOL TO POINT OUT IMPORTANT SAFETY PRECAUTIONS. IT MEANS--ATTENTION!!!
BECOME ALERT!!! YOUR SAFETY IS INVOLVED.

Record the following information about your unit so that you will be able to provide it in case of loss or theft.

MODEL NUMBER: - (Enter complete 8 digit number from model plate on unit)
PURCHASE DATE: ___ / ___ / ___ CODE NO.: _____ SERIAL NO.: _____
DEALER'S NAME AND ADDRESS: _____
CITY: _____ STATE: _____ TELEPHONE: _____

TOOLS REQUIRED FOR ASSEMBLY

- 2 - 7/16 inch Wrenches (or adjustable wrench)
- 1 - 1/2 inch Wrench (or adjustable wrench)
- 1 - Small Phillips Screwdriver with a 1/4 inch shank
- 1 - Hammer

SHIPPING CONTENTS

See Customer Assembly on page 26 & 27 for Seat & Hardware

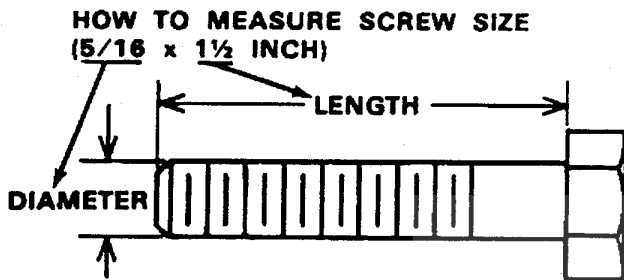

DANGER



This lawn tractor can be dangerous if carelessly used.

Read your Operator's Manual thoroughly before operating your lawn tractor.

Always wear safety glasses or eye shields while assembling or operating your lawn tractor.

DO NOT carry passengers at any time.

Keep your hands, feet, hair and loose clothing away from the discharge area, the underside of the mower deck or any moving parts while the engine is running.

DO NOT allow children or young teenagers to operate or be near your lawn tractor while it is operating.

ALWAYS GIVE THE FOLLOWING INFORMATION WHEN ORDERING REPAIR PARTS:
1. The PART NUMBER; 2. The PART NAME; 3. QUANTITY DESIRED; 4. The MODEL NUMBER (As shown on Model Plate).
SEND PART ORDERS AS PER INSTRUCTIONS ON THE FRONT PAGE.

DO NOT USE KEY NUMBERS WHEN ORDERING REPAIR PARTS, ALWAYS USE PART NUMBERS.

All replacement parts will be supplied in current production colors or in a neutral color.

A handling fee is applicable to small parts orders.

YOUR UNIT IS RIGHT HAND (RH) OR LEFT HAND (LH) AS YOU STAND BEHIND IT.

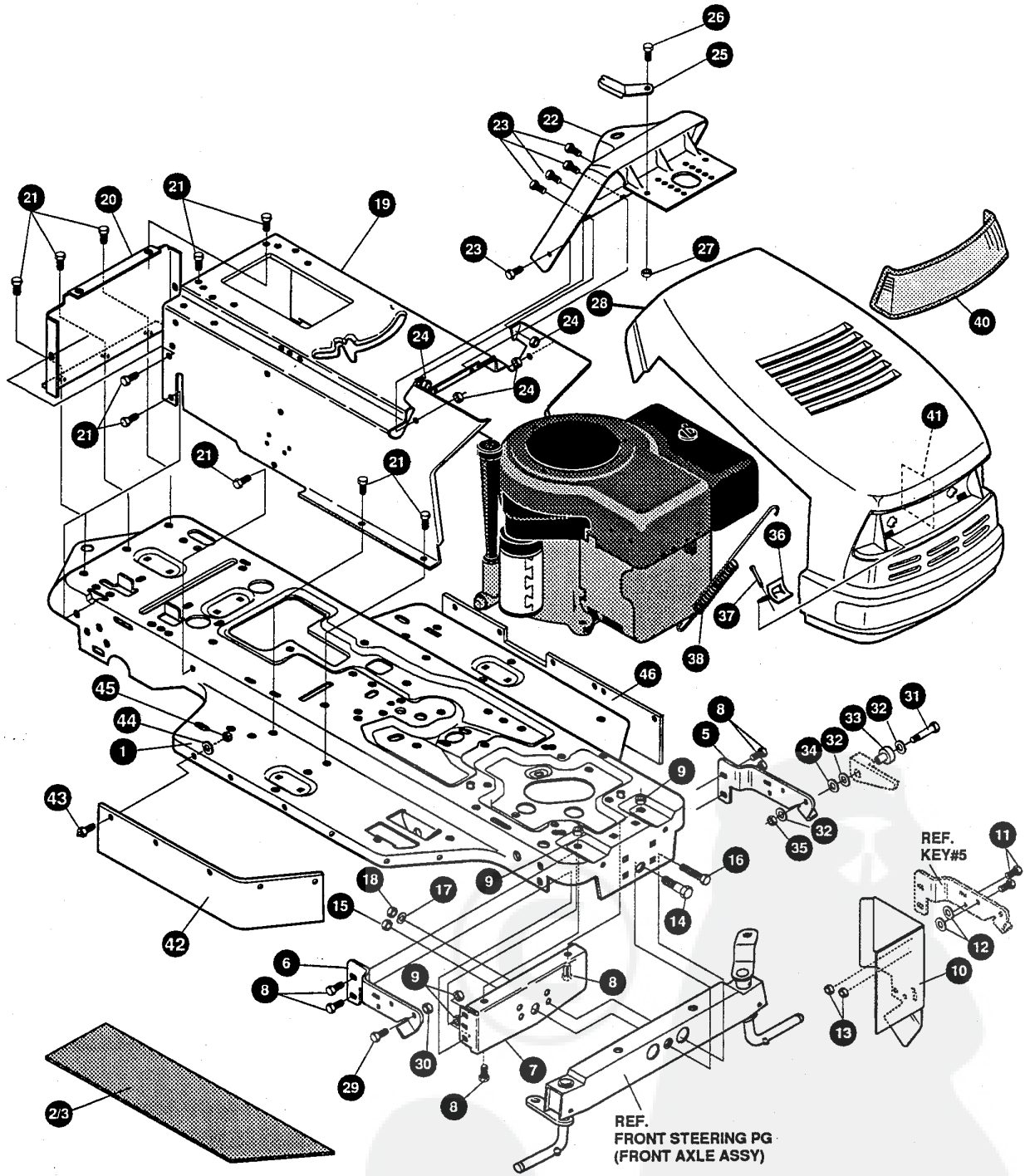

NOTE: ALWAYS USE ORIGINAL EQUIPMENT PARTS. Use of service/replacement parts other than original equipment parts may void your warranty.

ALL UNNUMBERED ITEMS ARE INTERCHANGEABLE WITH OPPOSITE SIDE

332874B

KEY#	PART#	DESCRIPTION	QTY
1	332319-860	MAIN FRAME SF RIDER TUV	1
2	302916	FOOT PAD, RH SF WIDE	1
3	326732	FOOT PAD, LH SF WIDE	1
5	313001-853	BRACKET, GRILLE SUPPORT LH	1
6	313002-853	BRACKET, GRILLE RH	1
7	56362-853	BRACKET, SUPPORT, FRONT AXLE-SF	1
8	328154	SCREW, 5/16-18X1.0WDFLLK	6
9	55273	NUT, 5/16-18 HXWDFLLK	6
10	312908-853	SHIELD, HEAT 11&12BS&TEC SF	1
11	180020	SCREW, 1/4-20X .75 HHC	2
12	311245	WASHER, FLAT.250X .75X INSULATE	2
13	1502	NUT, 1/4-20 REGHEXCTRLK	2
14	29616	BOLT, .625X1.890 HSSH 1/2-20	1
15	274654	NUT, 1/2-20 REGHXCTRLK	1
16	122201	SCREW, 3/8-16X2.75 HHC	2
17	2483	WASHER, .39IDX1.25DX.07 BELLVIL	2
18	1499	NUT, 3/8-16 REGHXCTRLK	2
19	331796-860	CONSOLE, SF NOMA DASH	1
20	56235-860	CONSOLE, REAR COVER	1
21	995346	SCREW, 1/4-20X .50 WAHHTAP	15
22	320466-860	DASH, SF NOMA DYNA STYLING	1
23	44811	SCREW, 1/4-20X .75 WAHHTAP	6
24	50352	NUT, 1/4-20 WDFLLK TOPLOCK	4
25	313021-853	GUIDE, HOOD SF&LF H13, H14, H15	2
26	180020	SCREW, 1/4-20X .75 HHC	2
27	51335	NUT, 1/4-20 WDFLWHIZ-LK	2
28	12506	HOOD, NOMA SMALL H-13	1
29	56676	BOLT, .375X .580 HSSH 5/16-18	1
30	1498	NUT, 5/16-18 REGHEXCTRLK	1
31	180042	SCREW, 1/4-20X1.75 HHC	1
32	120392	WASHER, FLAT .281X .63X.065	3
33	309532	BEARING FLANGED PLASTIC HOOD	1
34	311245	WASHER, FLAT.250X .75X INSULATE	1
35	1502	NUT, 1/4-20 REGHEXCTRLK	1
36	310801	ANCHOR, HOODLANYARD	1
37	121222	PIN, COTTER .090 DIA X .75LG	1
38	304784	SPRING, HOOD LATCH	1
40	302670	LENS, HEADLAMP DYNA HOODS	1
41	301452	FOIL, HEAT REFLECTOR	1
42	305395	BELT GUARD SF RUBBER 7 X 25.46	1
43	57034	SCREW, 10-24X .63 TRHMA	12
44	1501	WASHER, FLAT .203X .56X.040	12
45	308459	NUT, #10-24 HXHDNYLK	12
46	333360	TUV BELTGUARD, PEDAL LIFT	1
47	333311	PARTS MANUAL	1
48	333390	OPERATOR'S MANUAL (GERMAN)	1
49	327717	GRASS CATCHER MANUAL	1
50	330272	AIR ASSIST MANUAL (FRENCH)	1
51	330273	AIR ASSIST MANUAL (GERMAN)	1

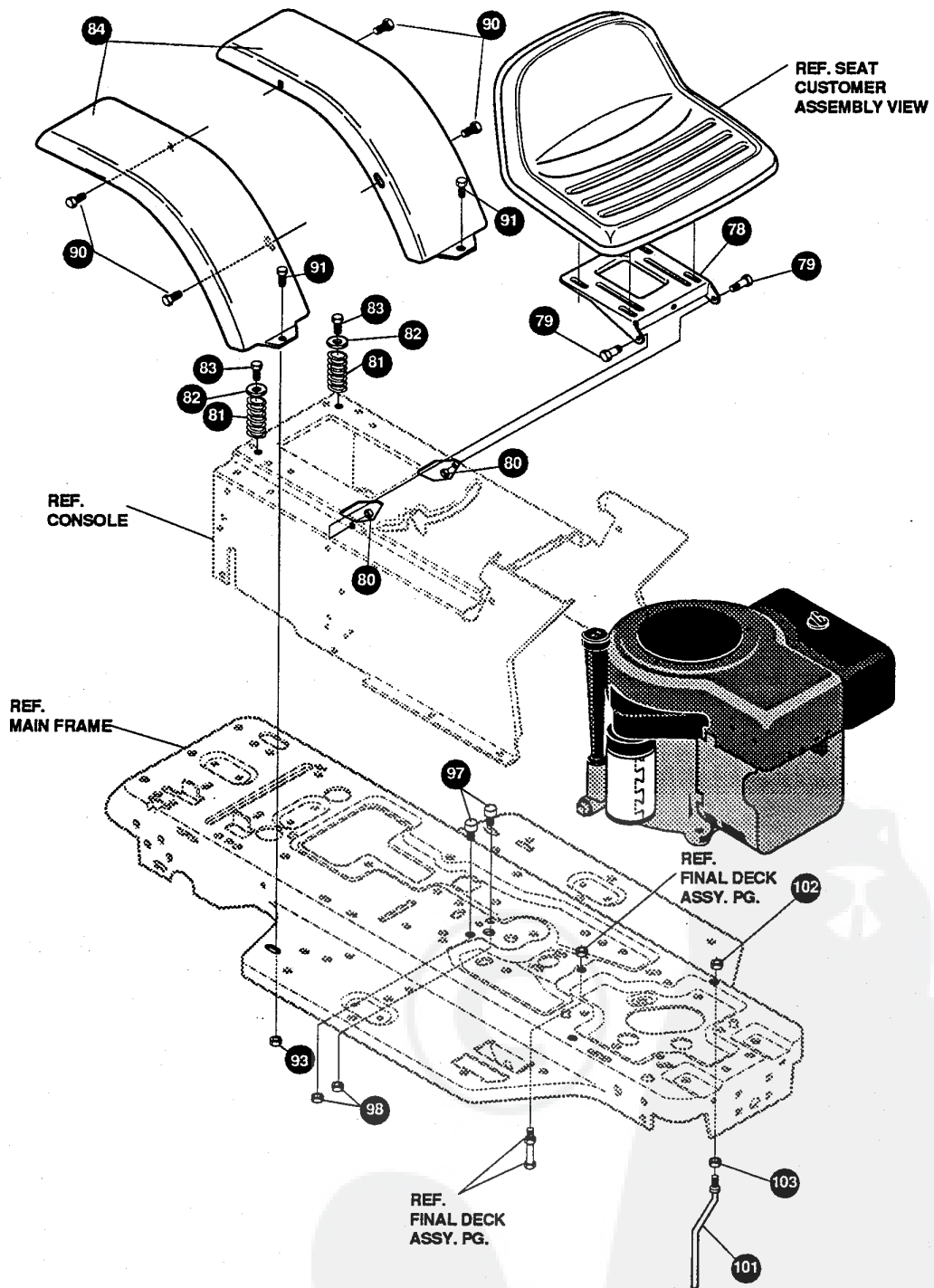

NOTE: ALWAYS USE ORIGINAL EQUIPMENT PARTS. Use of service/replacement parts other than original equipment parts may void your warranty.

ALL UNNUMBERED ITEMS ARE INTERCHANGEABLE WITH OPPOSITE SIDE

332874B

KEY#	PART#	DESCRIPTION	QTY
78	58367-860	PLATE,SEAT F5 SF,LF	1
79	20507	BOLT, .437X .156 HSH 5/16-18	2
80	1498	NUT, 5/16-18 REGHEXCTRLK	2
81	330463	SPRING, SEAT 1.500DX2.25LG	2
82	120392	WASHER, FLAT .281X .63X.065	2
83	995346	SCREW, 1/4-20X .50 WAHTAP	2
84	43970-860	FENDER F-1	2
90	995346	SCREW, 1/4-20X .50 WAHTAP	4
91	126216	BOLT, 5/16-18X .75 CARRLN	2
93	55273	NUT, 5/16-18 HXWDFLLK	2
97	53446	PIN, 5/16-18 HOOD LATCH	2
98	271184	NUT, 5/16-18 HEXKEPS	2
101	50653	GUIDE, BELT	1
102	41529	NUT, 3/8-16 HXCTRLKJAM	1
103	271190	NUT, 3/8-16 HEXKEPS	1

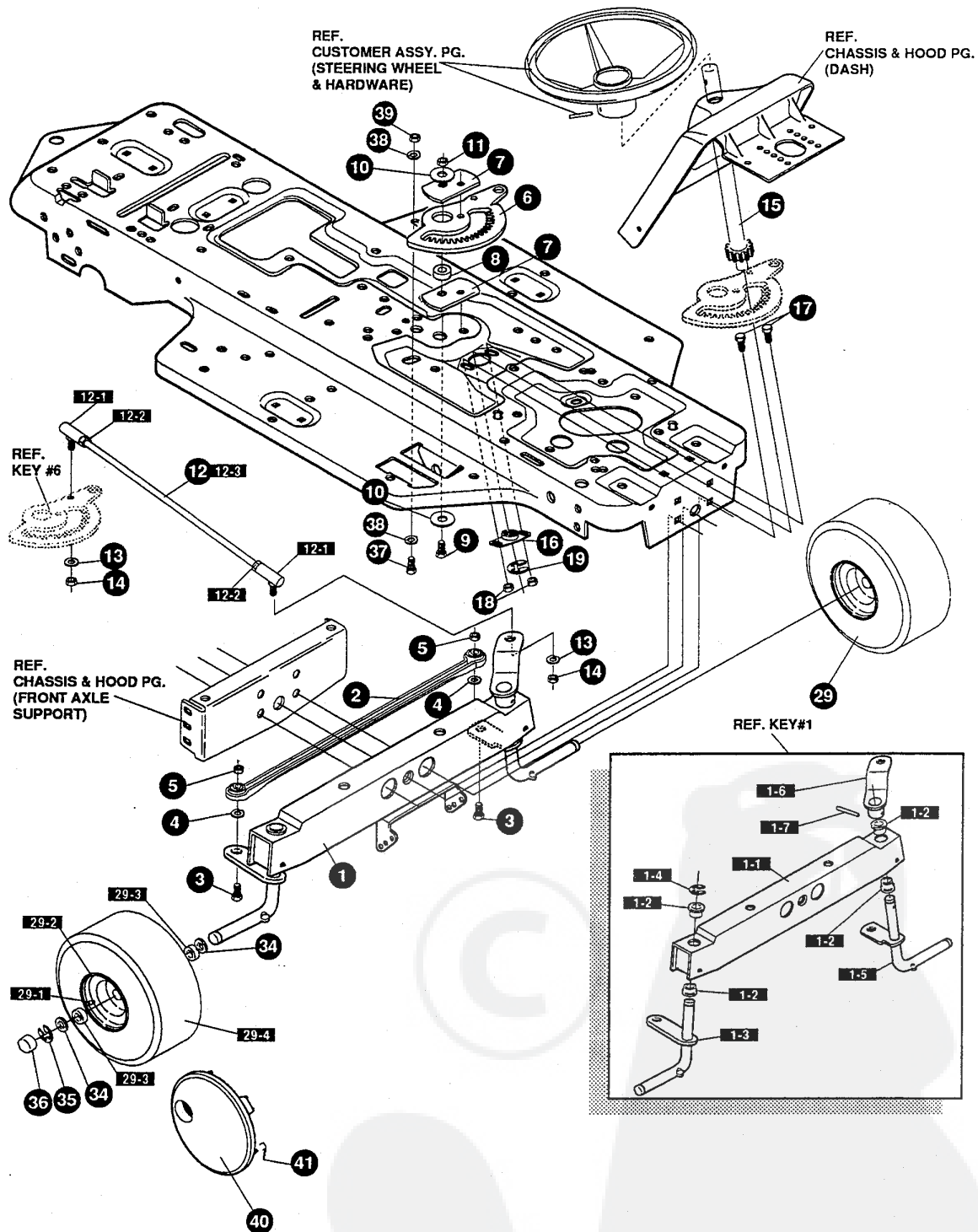

NOTE: ALWAYS USE ORIGINAL EQUIPMENT PARTS. Use of service/replacement parts other than original equipment parts may void your warranty.

ALL UNNUMBERED ITEMS ARE INTERCHANGEABLE WITH OPPOSITE SIDE

329496E

KEY#	PART#	DESCRIPTION	QTY
1	^	AXLE FRONT ASSY, SF LONG	1
1-1	324915-853	ASSY FRONT AXLE SF GS	1
1-2	50546	BRNG, FL .759IDX1.002ODX .75	4
1-3	310368	SPINDLE,ASSY,RH LONG SF	1
1-4	36625	RING, RETEX .57X.05TRU5133-75	1
1-5	310367	SPINDLE,ASSY,LH LONG SF	1
1-6	327619-853	ARM ASSY SF 4WS FRNT STRNG	1
1-7	454565	PIN, SPRING.250DIA X1.25LG HVPL	1
2	302688	ASSY,TIE ROD 19.31 LG	1
3	180124	SCREW, 3/8-16X1.25 HHC	2
4	120382	WASHER, REGSPTLK.393X.68X.10	2
5	1499	NUT, 3/8-16 REGHXCTRLK	2
6	324752	GEAR, SECTOR SF4WS HT	1
7	333289	PLATE SECT SF 4WS BLK	2
8	330021	BUSHING, SECTOR GEAR SF 4WS	1
9	181643	SCREW, 3/8-24X1.50 HHC	1
10	845	WASHER, FLAT .390X1.25X.119	2
11	412349	NUT, 3/8-24 HXCTRLK	1
12	328808	DRAG LINK ASSY 17.69LG	1
12-1	57158	BALL JOINT 3/8 THD SHORT STUD	2
12-2	124925	NUT, 3/8-24 REGHEXJAM	2
12-3	56190	DRAG LINK	1
13	120382	WASHER, REGSPTLK.393X.68X.10	2
14	120369	NUT, 3/8-24 REGHEX	2
15	327834	SHAFT, PIN-STEER BLK	1
16	325692	BRNG, FL .50 IDX1.370ODX	1
17	326505	SCREW, 1/4-20X.75 (TQ 30-35 FT#)	2
18	46931	NUT, 1/4-20 WDFL MAC-LOCK	2
19	20864	RING, RET E .39X.04TRU5133-50	1
29	302828	TIRE & RIM, PU 15X6.0X6 TUR	2
29-1	24167	VALVE STEM	
29-2	29829	RIM, WHEEL	
29-3	314416	BEARING, FLANGE	
29-4	TIRE-	SEE TIRE TREAD PAGE	
34	642	WASHER, FLAT .755X1.31X.075	4
35	36625	RING, RETEX .57X.05TRU5133-75	2
36	40394	HUB CAP, 1.500ID X 7/8LG	2
37	180124	SCREW, 3/8-16X1.25 HHC	1
38	120394	WASHER, FLAT .406X .81X.065	2
39	45171	NUT, 3/8-16 HWDFL WHIZ-LOCK	1
40	304444	HUB CAP, 6" EURO	2
41	306669	CLIP,HUBCAP TINN #C25467-017-4	8

^ ORDER INDIVIDUAL PARTS

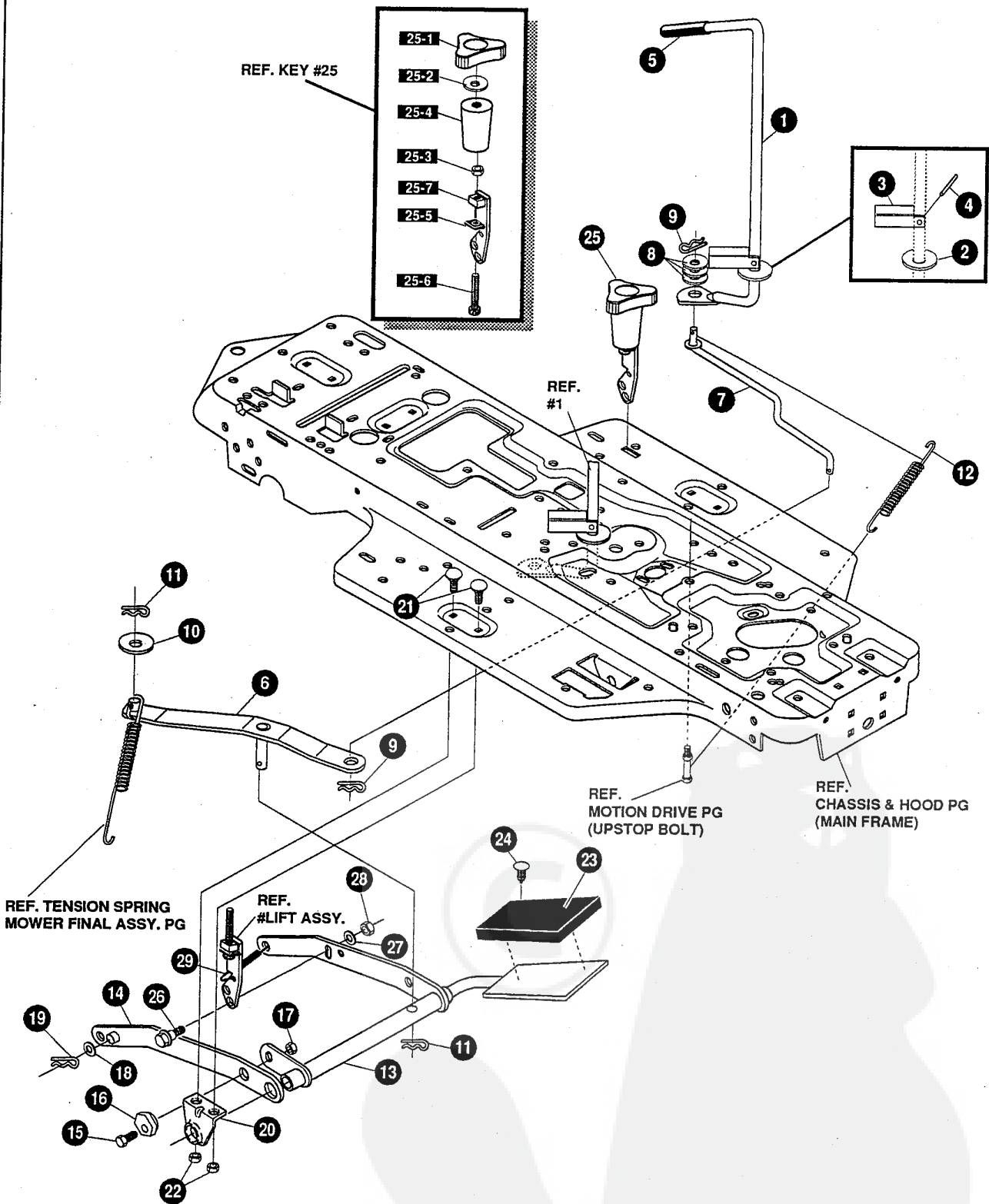

NOTE: ALWAYS USE ORIGINAL EQUIPMENT PARTS. Use of service/replacement parts other than original equipment parts may void your warranty.

ALL UNNUMBERED ITEMS ARE INTERCHANGEABLE WITH OPPOSITE SIDE

331233B

E3554-110**MOWER SUSPENSION ASSEMBL**

KEY#	PART#	DESCRIPTION	QTY
1	325591	LEVER,CLUTCH RH PTO	1
2	22265	WASHER, FLAT .515X1.38X.119	1
3	305225	STOP, PTO ENGAGE	1
4	326386	PIN, SPRING.187DIAX1.13LG HD	1
5	331624	KNOB, ROUND 1.50DIA OR GRIP	1
6	325587-853	STRAP ASSY, PTO BELCRANK	1
7	325590	ROD, BELCRANK LINK	1
8	274517	WASHER, FLAT .406X .73X.063	3
9	8260	PIN, HAIR .091 DIAX1.66LG	2
10	25210	WASHER, FLAT .386X1.25X.09HT	1
11	8260	PIN, HAIR .091 DIAX1.66LG	2
12	325802	SPRING, .69X7.75X.0897TENSION	1
13	326533-853	LIFT ASSY,LH PEDAL-LIFT	1
14	325130-853	LIFT ASSY, RH	1
15	180079	SCREW, 5/16-18X1.00 HHC	1
16	58247	NUT, ADJUST	1
17	1498	NUT, 5/16-18 REGHEXCTRLK	1
18	417098	WASHER, FLAT .531X1.06X.063	2
19	8260	PIN, HAIR .091 DIAX1.66LG	2
20	325495-853	BRACKET, REAR HANG SUSP	1
21	330967	BOLT, 5/16-18X1.00 CAR	4
22	1498	NUT, 5/16-18 REGHEXCTRLK	4
23	328596	PAD, LIFT PEDAL	1
24	309235	FASTENER, RATCHET BLACK	1
25	327934	ASSY LATCH SUS MOWER SF	1
25-1	325860	KNOB, FLUTED TORQUE BLACK	1
25-2	446363	WASHER, FLAT .375X .88X.082	1
25-3	45905	NUT, 3/8-16 HWDFLK MACK	1
25-4	326113	COVER, TOP SLEEVE PEDAL-LIFT	1
25-5	324983	WASHER, RUBBER 3/8X.75SQ	1
25-6	325832	BOLT, SUS MOWER LATCH	1
25-7	325831-853	LATCH, SUS MOWER	1
26	25086	BOLT, .500X .375 HSSH 5/16-18	1
27	4230	WASHER, FLAT .328X .68X.104	1
28	1498	NUT, 5/16-18 REGHEXCTRLK	1
29	35410	SPRING .071 X .62 X 4.37	1

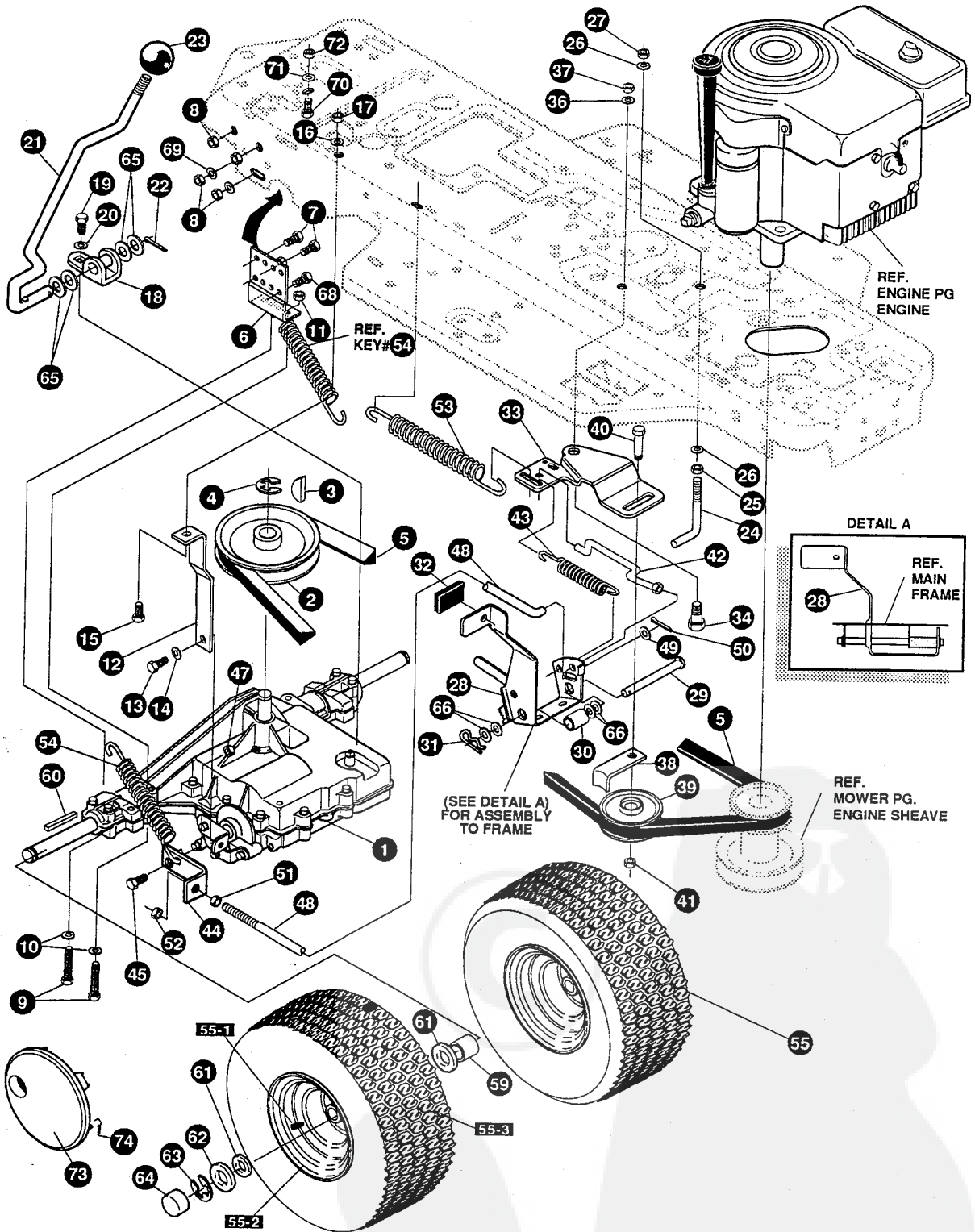

NOTE: ALWAYS USE ORIGINAL EQUIPMENT PARTS. Use of service/replacement parts other than original equipment parts may void your warranty.

ALL UNNUMBERED ITEMS ARE INTERCHANGEABLE WITH OPPOSITE SIDE

333254A

KEY#	PART#	DESCRIPTION	QTY
1	^	TRANSAXLE FOOTE 4360-5	1
2	303109	PULLEY, 6.6 OD V4L T/A	1
3	50795	KEY, HI-PRO 606 .75DIA X.187WD	1
4	22053	RING, RETEX .58X.035TRU5100-62	1
5	54758	BELT, V 4L 82.00 SF DRIVE	1
6	326615-853	BRACKET, TRANSAXLE	2
7	180077	SCREW, 5/16-18X .75 HHC	4
8	1498	NUT, 5/16-18 REGHEXCTRLK	8
9	180091	SCREW, 5/16-18X2.50 HHC	4
10	120393	WASHER, FLAT .344X .69X.065	4
11	1498	NUT, 5/16-18 REGHEXCTRLK	4
12	323126	BRKT, STABILIZER BLK	1
13	35498	SCREW, 5/16-18X .75 WAHHTAP	1
14	120638	WASHER, HVSPTLK .328X.60X.09	1
15	180079	SCREW, 5/16-18X1.00 HHC	1
16	138485	WASHER, EXLK .320X.61X.03	1
17	1498	NUT, 5/16-18 REGHEXCTRLK	1
18	331393	BRACKET, SHIFT F4360	1
19	56255	SCREW, 1/4-28X .75 NYLHHC	1
20	57157	WASHER, .750X.250 SP-TRANSAXLE	1
21	331800	SHIFT LEVER (DANA)	1
22	137185	PIN, COTTER .125 DIA X1.00LG	1
23	55514	KNOB, ROUND 1.50 DIA BLACK	1
24	49896	BELT GUIDE	1
25	271184	NUT, 5/16-18 HEXKEPS	1
26	120393	WASHER, FLAT .344X .69X.065	2
27	1498	NUT, 5/16-18 REGHEXCTRLK	1
28	331836	ASSY, PEDAL, BRAKE, CLUTCH SF	1
29	319676	PIN, CLEVIS .500DX4.87LG	1
30	331972	SPACER, SLEV .53 X .62X1.240	1
31	56180	PIN, HAIR .091 DIA X1.62LG	1
32	48761	PAD, CLUTCH/BRAKE PEDAL	1
33	321969	IDLER ARM BRKT TRACTION SF	1
34	329989	BOLT, .625X .135 HSSH 5/16-18	1
36	45602	WASHER, FLAT .333X .87X.119	1
37	1498	NUT, 5/16-18 REGHEXCTRLK	1
38	39659	RETAINER, BELT	1
39	35374	PULLEY, IDLER V4L 3.06X .62	1
40	45892	BOLT, 3/8-16X1.50 CARRSN	1
41	1499	NUT, 3/8-16 REGHXCTRLK	1
42	333175	CLUTCH ROD ASSY, .268 DIA 3.92	1
43	326780	SPRING, 3/8ODX2.18 X.055 TENSION	1
44	323127	BRKT, BRAKE ROD BLK	1
45	20507	BOLT, .437X .156 HSSH 5/16-18	1
47	1498	NUT, 5/16-18 REGHEXCTRLK	1
48	323222	BRAKE ROD, RIDER BLK	1
49	120393	WASHER, FLAT .344X .69X.065	1
50	121222	PIN, COTTER .090 DIA X .75LG	1
51	271184	NUT, 5/16-18 HEXKEPS	1
52	1498	NUT, 5/16-18 REGHEXCTRLK	1
53	327867	SPRING, 3/4 ODX7.75X.091 TENSION	1
54	35410	SPRING .071 X .62 X 4.37	1
55	42090	TIRE & RIM, PU 18X6.5X8TURF	2
55-1	24167	VALVE STEM	
55-2	36182	RIM, WHEEL	
53-3	TIRE	REFER TO TIRE TREAD PAGE	
59	57479	SPACER, SLEV .75 X1.25X1.32	2
60	52928	KEY, SQUARE .187SQX2.25LG	2
61	642	WASHER, FLAT .755X1.31X.075	4
62	42815	WASHER, FLAT .755X1.53X.07	2
63	36625	RING, RETEX .57X.05TRU5133-75	2
64	40394	HUB CAP, 1.500ID X 7/8LG	2
65	5950	WASHER, FLAT .505X .88X.13	4
66	2968	WASHER, FLAT .504X .75X.059	4
68	327917	SCREW, 5/16-18X1.50HHCFT	4
69	73787	WASHER, FLAT .330X .75X.1793	4
70	180022	SCREW, 1/4-20X1.00 HHC	1
71	120380	WASHER, REGSPTLK.263X.49X.07	1
72	120375	NUT, 1/4-20 REGHEX	1
73	304441	HUB CAP, 8" EURO	2
75	306669	CLIP, HUBCAP TINN #C25467-017-4	10

^ CONTACT YOUR NEAREST TRANSAXLE DEALER FOR PARTS AND SERVICE

E3554-110

REPAIR PARTS

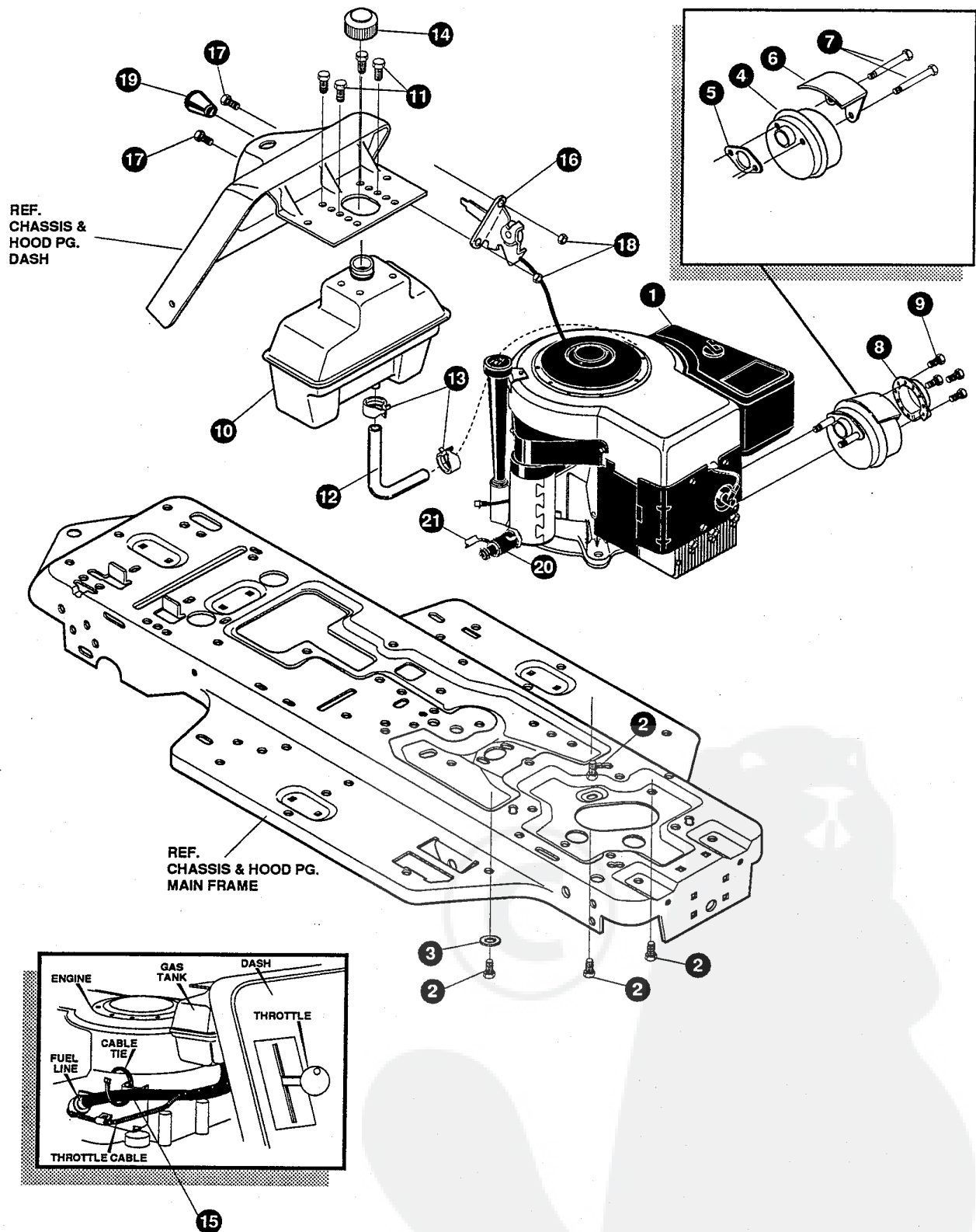

NOTE: ALWAYS USE ORIGINAL EQUIPMENT PARTS. Use of service/replacement parts other than original equipment parts may void your warranty.

ALL UNNUMBERED ITEMS ARE INTERCHANGEABLE WITH OPPOSITE SIDE

326553C

E3554-110**ENGINE & CONTROL ASSEMBL**

KEY#	PART#	DESCRIPTION	QTY
1	^	ENGINE, 12-12.5HP BS IC DUAL	1
2	50947	SCREW, 3/8-16X1.25 WAHHTAPBLKP	4
3	138489	WASHER, EXLK .384X.69X.04	1
4	57908	MUFFLER-DOM/EXP ROUND	1
5	46708	GASKET, MUFFLER	1
6	54767	SHIELD, HEAT, FOR ROUND MUFFLER	1
7	54980	SCREW, 5/16-18X3.50 HHC	2
8	56472	DEFLECTOR SIDE OUT (BS222573)	1
9	35287	SCREW, #8-32X .38 HHWATAP	4
10	314989	TANK, FUEL 1 GAL CLEAR	1
11	300303	SCREW, .25X.75X.51HHWAPLASTITE	4
12	42258	TUBING, .25X.50X BULK GAS LINE	12"
13	47345	CLAMP, HOSE SCREW TYPE	2
14	46704	CAP, GAS 1-1/2-7 THD BLK	1
15	57444	TIE, CABLE BLACK NYLON 5.62L	1
16	320031	THROTTLE CONTROL	1
17	274707	SCREW, 10-24X .50 WAHMA	2
18	308459	NUT, #10-24 HXHDNYLK	2
19	50607	KNOB, ROUND THROTTLE BLACK	1
20	325547	OIL DRAIN VALVE ASSEMBLY	1
21	327422	CAP, OIL DRAIN VALVE ASM. YELLOW	1

^ SEE ENGINE MANUAL

E3554-110

REPAIR PARTS

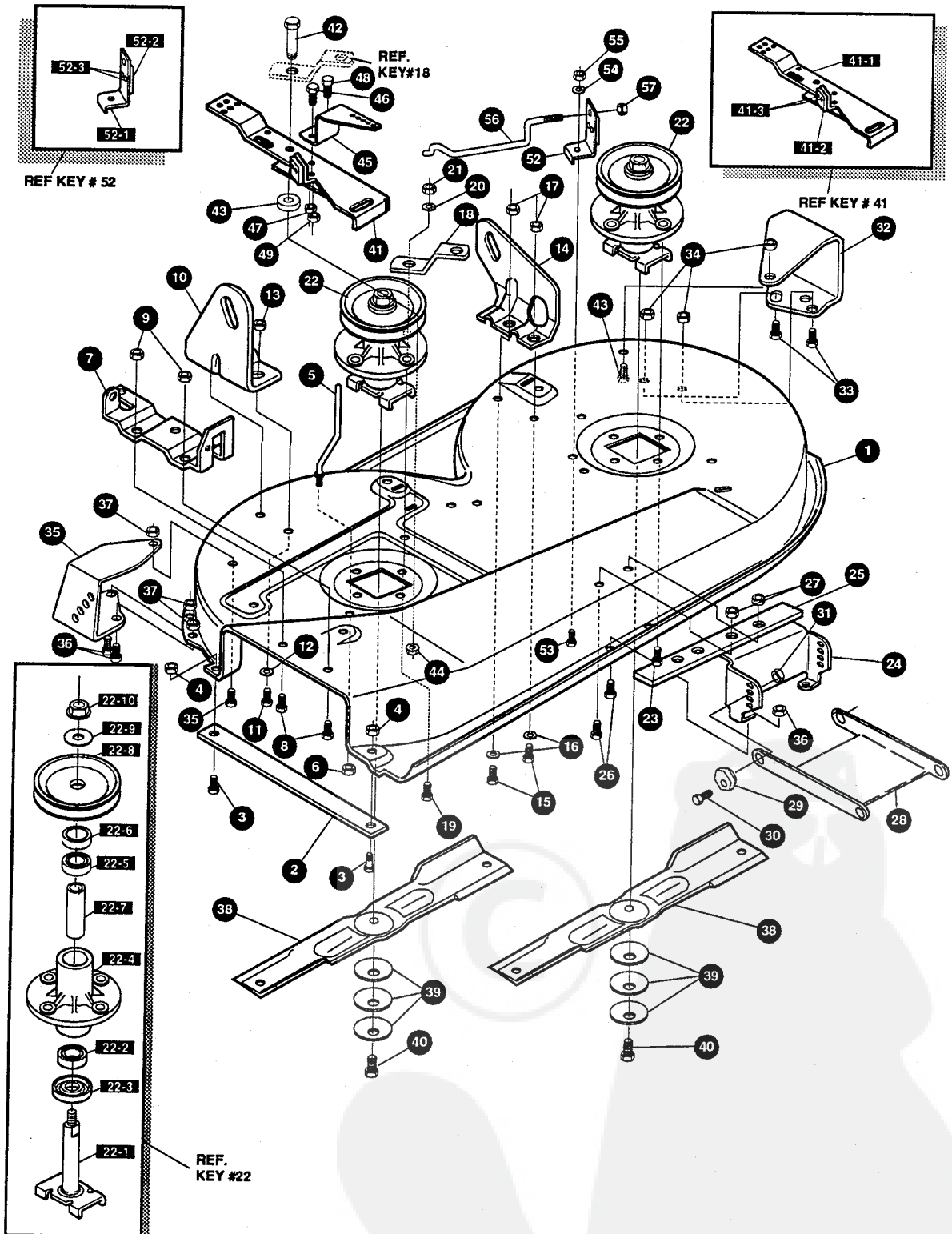

NOTE: ALWAYS USE ORIGINAL EQUIPMENT PARTS. Use of service/replacement parts other than original equipment parts may void your warranty.

ALL UNNUMBERED ITEMS ARE INTERCHANGEABLE WITH OPPOSITE SIDE

332343D

KEY#	PART#	DESCRIPTION	QTY
1	325106	38" DECK KIT	1
2	326295-853	BAR, SKID	1
3	120230	BOLT, 5/16-18X1.25 CARRLN	2
4	271184	NUT, 5/16-18 HEXKEPS	2
5	57318	GUIDE, BELT 5/16-18 THD	1
6	1498	NUT, 5/16-18 REGHEXCTRLK	1
7	313928-853	BRACKET, CHUTE BLK	1
8	180073	SCREW, 5/16-18X .50 HHC	2
9	1498	NUT, 5/16-18 REGHEXCTRLK	2
10	313929-853	LIFT BRACKET, REAR RH BLK	1
11	180077	SCREW, 5/16-18X .75 HHC	2
12	120393	WASHER, FLAT .344X .69X.065	2
13	1498	NUT, 5/16-18 REGHEXCTRLK	2
14	310667	BRACKET,DECK LIFTREAR LHBLK	1
15	180077	SCREW, 5/16-18X .75 HHC	2
16	120393	WASHER, FLAT .344X .69X.065	2
17	1498	NUT, 5/16-18 REGHEXCTRLK	2
18	315302-853	BRACKET, IDLER SUPPORT	1
19	300345	SCREW, 5/16-18X1.38 WAHHTAP	1
20	120393	WASHER, FLAT .344X .69X.065	1
21	1498	NUT, 5/16-18 REGHEXCTRLK	1
22	56424-853	QUILL ASSY, 36/39/40/43	2
22-1	56425	SHAFT/SADDLE 36"	1
22-2	49562	BEARING, BALL 6203-2AA(SEALS)-C3	1
22-3	50616	DUST SHIELD	1
22-4	55547	QUILL CASTING (1046)	1
22-5	49562	BEARING, BALL 6203-2AA(SEALS)-C3	1
22-6	50818	SPACER, SLEV .669X .88X3.797	1
22-7	51449	SPACER, SLEV .672X .93X .438PM	1
22-8	313898	PULLEY ASSY	1
22-9	56365	WASHER, SPECIAL QUILL	1
22-10	1282	NUT, 7/16-20 WDFLLK	1
23	35498	SCREW, 5/16-18X .75 WAHHTAP	7
24	312526	LIFT SUPPORT FRONT DECK	1
25	328155-853	PLATE-MOUNTING	1
26	180077	SCREW, 5/16-18X .75 HHC	4
27	1498	NUT, 5/16-18 REGHEXCTRLK	4
28	58305-853	BRACKET, LINK DECK FRONT	1
29	58247	NUT, ADJUST	2
30	180079	SCREW, 5/16-18X1.00 HHC	2
31	1498	NUT, 5/16-18 REGHEXCTRLK	2
32	312477	WHEEL BRACKET, LH BLK	1
33	180077	SCREW, 5/16-18X .75 HHC	3
34	1498	NUT, 5/16-18 REGHEXCTRLK	3
35	300102-853	WHEEL BRKT, RH	1
36	180077	SCREW, 5/16-18X .75 HHC	3
37	1498	NUT, 5/16-18 REGHEXCTRLK	3
38	306932-853	BLADE, 19.69 HI-LIFT BLK	2
39	2483	WASHER, 39IDX1.25DX.07 BELLVIL	6
40	39573	SCREW, 3/8-24X1.00 NYLHHC	2
41	300491-853	BRACKET, IDLER ARM/BRAKE	1
41-1	300490-853	IDLER ARM 36,38,39, &45SD	1
41-2	306973	BRAKE PAD - HARD - 232AF	1
41-3	41601	RIVET, OVSET .187DIA X .50LG ST	2
42	300180	BOLT, .50 X1.88 HSH 3/8-16	1
43	996416	WASHER, FLAT .391X1.00X.125	1
44	45171	NUT, 3/8-16 HWDFL WHIZ-LOCK	1
45	326249-853	BRACKET, EXTENSION IDLER	1
46	180077	SCREW, 5/16-18X .75 HHC	1
47	1498	NUT, 5/16-18 REGHEXCTRLK	1
48	180020	SCREW, 1/4-20X .75 HHC	1
49	1502	NUT, 1/4-20 REGHEXCTRLK	1
52	303247-853	ASSY.BLADE BRAKE 36,39,45	1
52-1	303246	BRAKE ARM,	1
52-2	306973	BRAKE PAD - HARD - 232AF	1
52-3	135624	RIVET, TRSET .185DIA X .41LG ST	2
53	180077	SCREW, 5/16-18X .75 HHC	1
54	120393	WASHER, FLAT .344X .69X.065	1
55	1498	NUT, 5/16-18 REGHEXCTRLK	1
56	315306	ROD, BRAKE, 14.7 39" DECK ZINC	1
57	1502	NUT, 1/4-20 REGHEXCTRLK	1

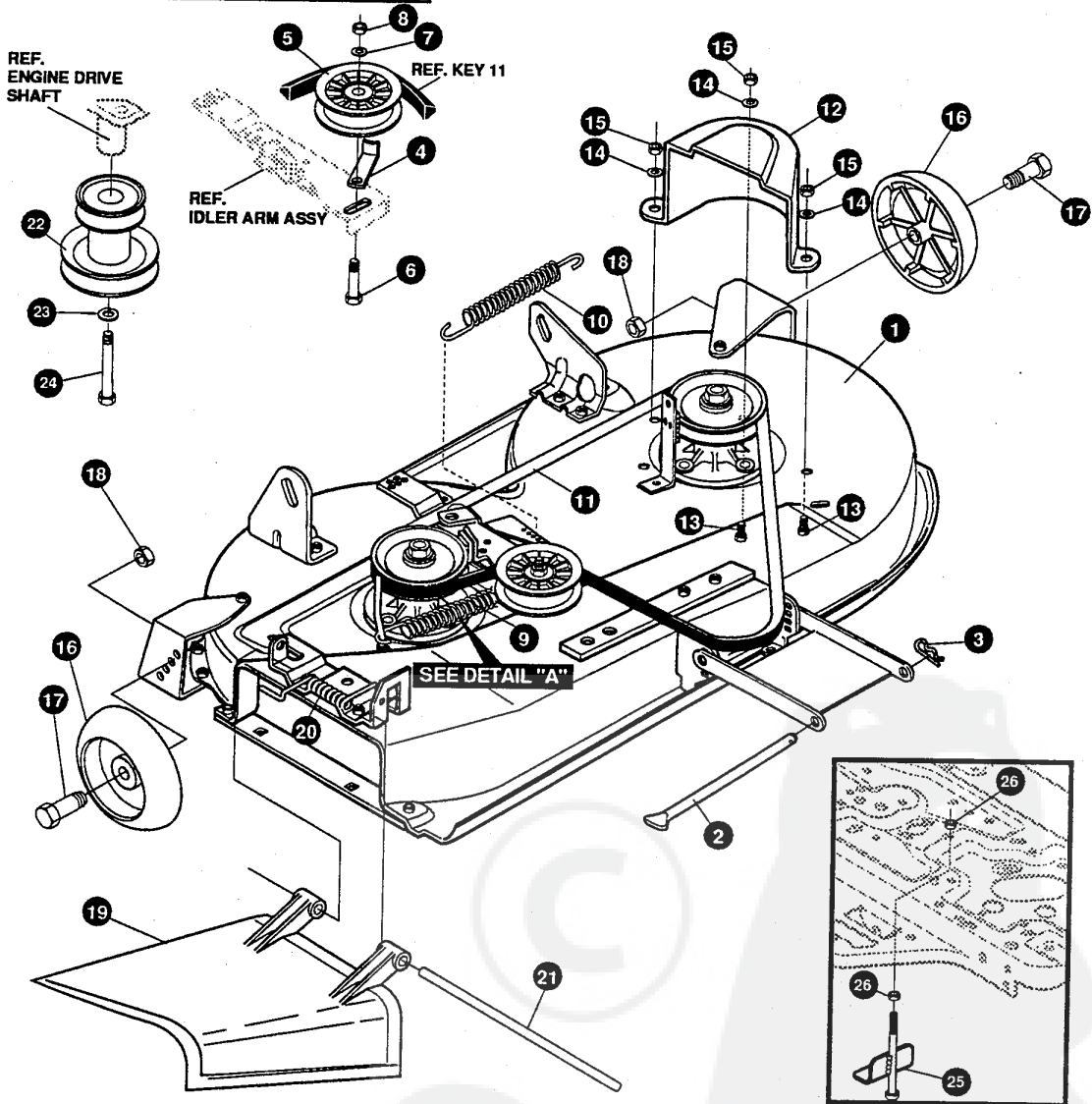
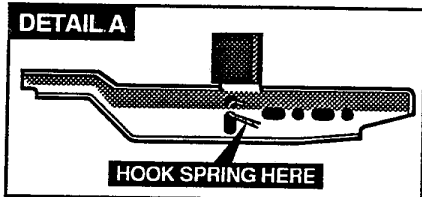

NOTE: ALWAYS USE ORIGINAL EQUIPMENT PARTS. Use of service/replacement parts other than original equipment parts may void your warranty.

ALL UNNUMBERED ITEMS ARE INTERCHANGEABLE WITH OPPOSITE SIDE

332344B

KEY#	PART#	DESCRIPTION	QTY
1	329456	ASM.DECK 39SUS SF/AIR ASST	1
2	58306	ROD, DECK HITCH	1
3	8260	PIN, HAIR .091 DIA X 1.66 LG	1
4	1346	RETAINER, BELT	1
5	310326	PULLEY, IDLER BFF 4.00 WIDE FL	1
6	57325	BOLT, 3/8-16 X 2.00 CARRSN	1
7	120382	WASHER, REGSPTLK.393X.68X.10	1
8	120377	NUT, 3/8-16 REGHX	1
9	322064	SPRING, .75X8.4X.105 TENSION	1
10	326256	SPRING, .75X10.0X.105 TENSION	1
11	300680	BELT, V 5L 77.75 KEVLAR	1
12	328257	GUARD, BELT LH PLASTIC	1
13	180077	SCREW, 5/16-18 X .75 HHC	3
14	120393	WASHER, FLAT .344X .69X.065	3
15	1498	NUT, 5/16-18 REGHEXCTRLK	3
16	302611	GAUGE WHEEL, EURO 6.00 O D X 1.38 W D	2
17	23763	BOLT, .500 X 1.390 H H S H 3/8-16	2
18	1499	NUT, 3/8-16 REGHXCTRLK	2
19	57818	CHUTE DEFLECTOR 36", 39", 45"	1
20	314975	SPRING, TORSION CHUTE DEFLECTOR	1
21	57317	PIVOT ROD, CHUTE	1
22	328034	PULLEY, ENG V3L 4.00 OFFSET	1
23	120383	WASHER, REGSPTLK.459X.78X.12	1
24	433146	SCREW, 7/16-20 X 4.25 HHC BLK	1
25	328630	ASSEMBLY HOSE MTG	1
26	1499	NUT, 3/8-16 REGHXCTRLK	2

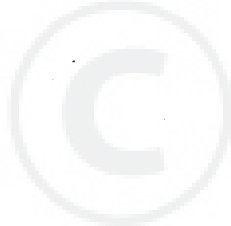

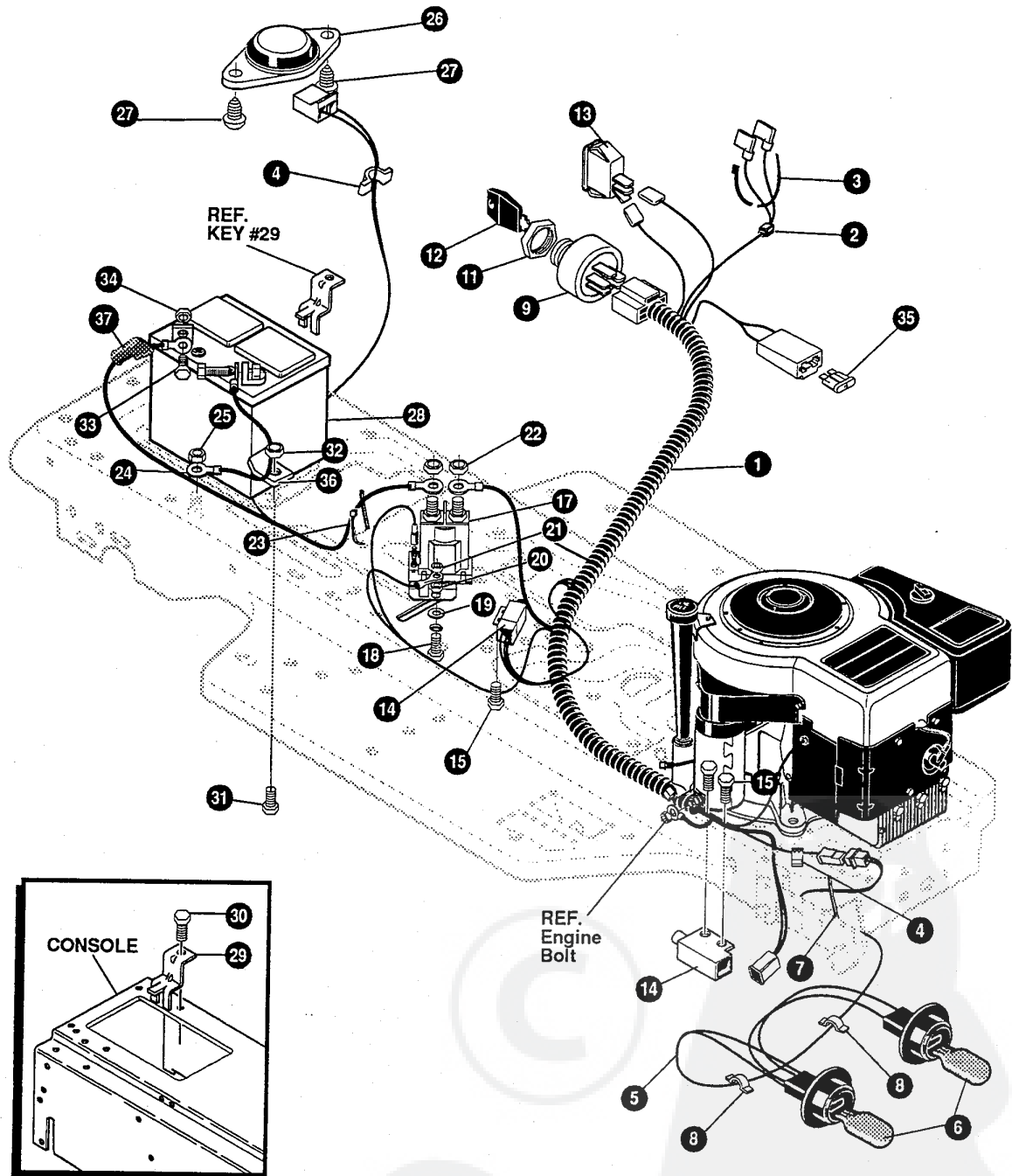

NOTE: ALWAYS USE ORIGINAL EQUIPMENT PARTS. Use of service/replacement parts other than original equipment parts may void your warranty.

ALL UNNUMBERED ITEMS ARE INTERCHANGEABLE WITH OPPOSITE SIDE

332009A

KEY#	PART#	DESCRIPTION	QTY
1	331450	WIRE HARNESS SF, W/AMP	1
2	322298	SPLICER	1
3	57444	TIE, CABLE BLACK NYLON 5.62L	1
4	41482	PRESS CLIP, 1.380LG .255ID	2
5	303064	ASSY, LIGHT WIRE-1/4 TURN	1
6	52572	BULB, HEADLAMP	2
7	57444	TIE, CABLE BLACK NYLON 5.62L	1
8	41482	PRESS CLIP, 1.380LG .255ID	2
9	327355	SWITCH-IGN. (AFTER FIRE) 3 POSN	1
11	327352	NUT, 5/8-8ACME DELTA FOR BOOT	1
12	327350	KEY, IGNITION DELTA	1
13	300334	LIGHT SWITCH ON/OFF PANEL MNT	1
14	57476	SWITCH, SCR MNT DP NC NO BLK	2
15	300302	SCREW, #10 X .50 HHTAPPST BLK	4
17	53716	SOLENOID	1
18	187745	SCREW, 1/4-20X .75 HXSEMMA	2
19	1084	WASHER, FLAT .281X1.00X.063PL	1
20	1502	NUT, 1/4-20 REGHEXCTRLK	2
21	271172	NUT, 1/4-20 REGHEXKEPS	1
22	271187	NUT, 5/16-24 HKEPS	2
23	57444	TIE, CABLE BLACK NYLON 5.62L	1
24	55511	WIRE, GROUND, 12.5"	1
25	271184	NUT, 5/16-18 HEXKEPS	1
26	57547	SWITCH, SEAT	1
27	160505	SCREW, 1/4-20X .38PHPNHMA	2
28	302257	BATTERY, 12V	1
29	329175	BATTERY BRACKET	1
30	995346	SCREW, 1/4-20X .50 WAHHTAP	1
31	187745	SCREW, 1/4-20X .75 HXSEMMA	1
32	1502	NUT, 1/4-20 REGHEXCTRLK	1
33	180020	SCREW, 1/4-20X .75 HHC	2
34	271172	NUT, 1/4-20 REGHEXKEPS	2
35	302031	FUSE SPADE TYPE 32V 15A	1
36	9149	BRKT, CABLE RETAIN	1
37	308201	INSULATOR, BATTERY BOOT EURO	1

WIRING SCHEMATIC

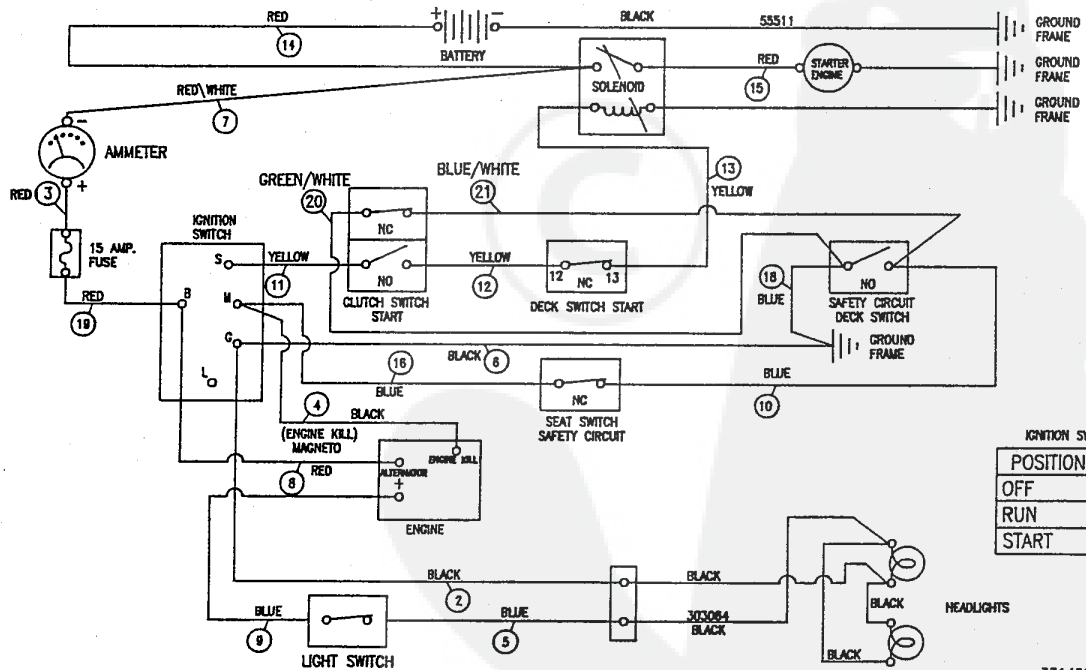

IGNITION SWITCH 327355

POSITION	G	M	L	B	S
OFF	●	●			
RUN			●	●	
START				●	●

331450

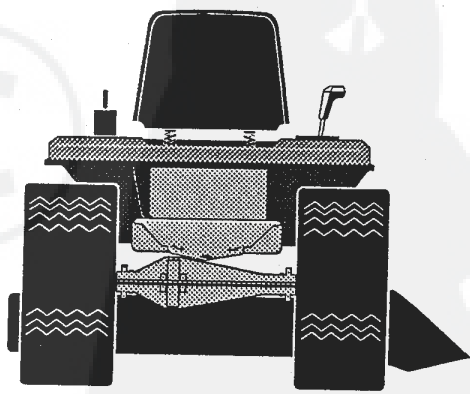
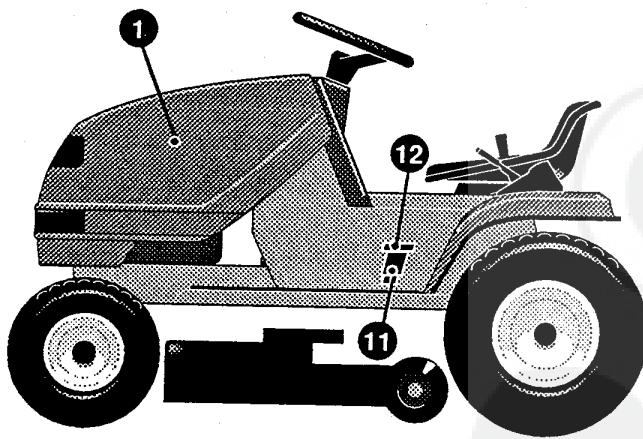
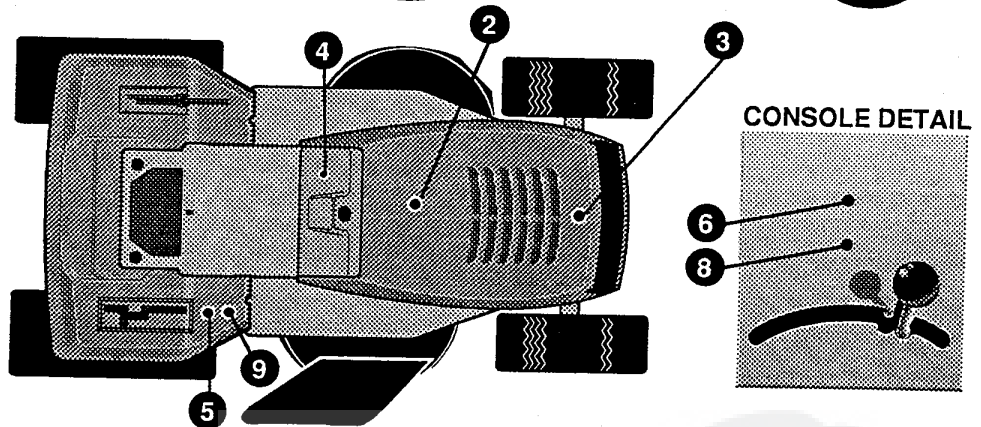
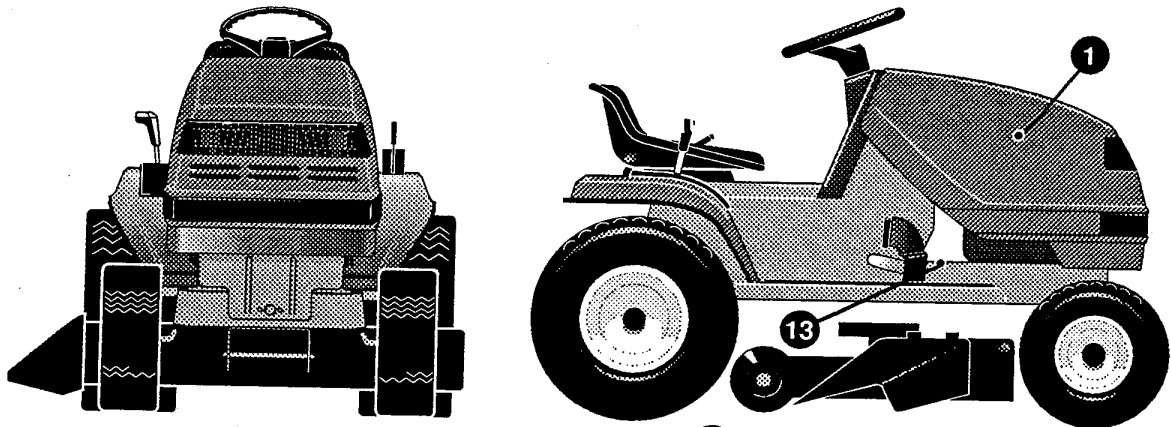

NOTE: ALWAYS USE ORIGINAL EQUIPMENT PARTS. Use of service/replacement parts other than original equipment parts may void your warranty.

ALL UNNUMBERED ITEMS ARE INTERCHANGEABLE WITH OPPOSITE SIDE

332897A

KEY#	PART#	DESCRIPTION	QTY
1	305603	PAD, 18 X 6 FOAM HOOD	2
2	307276	PAD, 15 X 7 FOAM HOOD	1
3	307277	PAD, 12 X 4 FOAM HOOD	1
4	324989	DECAL DASH, DYNAMARK	1
5	68902	DECAL, WARNING, FRENCH/GERMAN	1
6	69524	DECAL, INSTRUCT CONSOLE TOP GER	1
8	301104	DECAL, CONSOLE TOP SHIFT 5-SP	1
9	305770	DECAL, CAUTION TRIANGLE EUROPE	1
11	320892	DECAL, INSTR PEDAL LIFT	1
12	327146	DECAL, PEDAL-LIFT INDICATOR	1
13	68903	DECAL, BRAKE/CLUTCH ISO	1

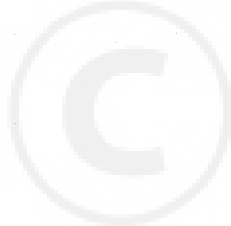

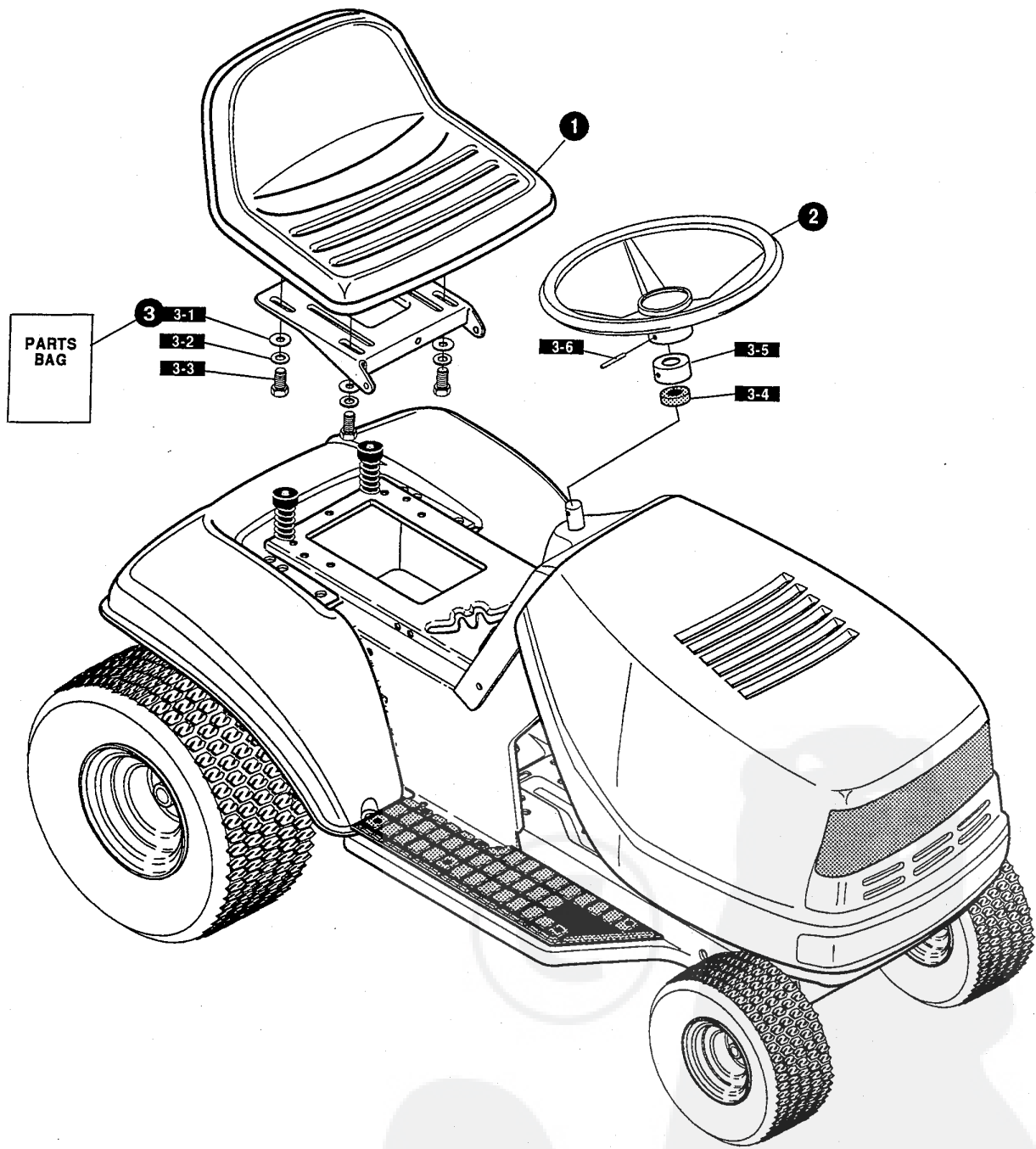

NOTE: ALWAYS USE ORIGINAL EQUIPMENT PARTS. Use of service/replacement parts other than original equipment parts may void your warranty.

ALL UNNUMBERED ITEMS ARE INTERCHANGEABLE WITH OPPOSITE SIDE

327405D

KEY#	PART#	DESCRIPTION	QTY
1	57455	SEAT, MICHIGAN GEN, W/SW HOLE	1
2	330510	STEERING WHEEL	1
3		PARTS BAG	
3-1	120393	WASHER, FLAT .344X .69X.065	4
3-2	120638	WASHER, HVSP TLK .328X.60X.09	4
3-3	180077	SCREW, 5/16-18X .75 HHC	4
3-4	331322	COVER, STEERING SHAFT	1
3-5	301413	SPACER, STEERING SHAFT	1
3-6	456378	PIN, SPRING.250DIA X2.00LG HVPL	1

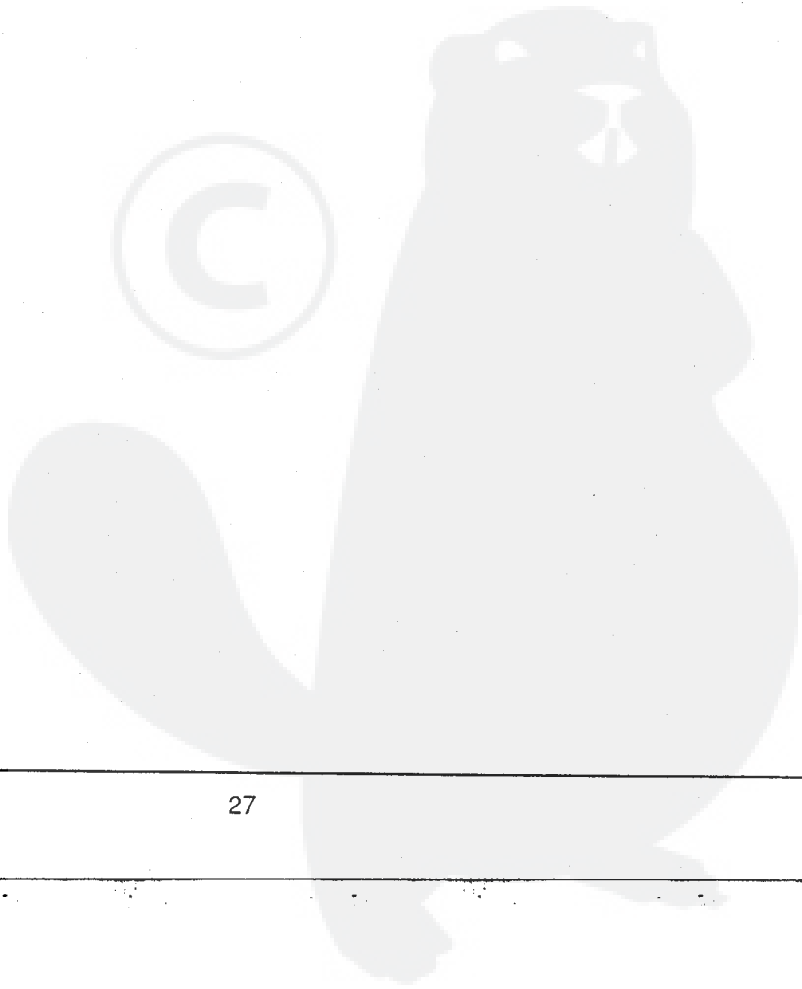

TREAD PATTERNS

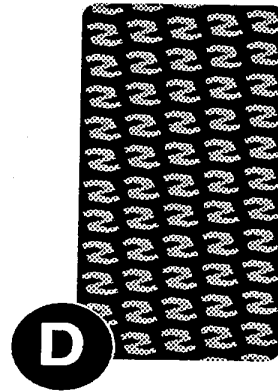
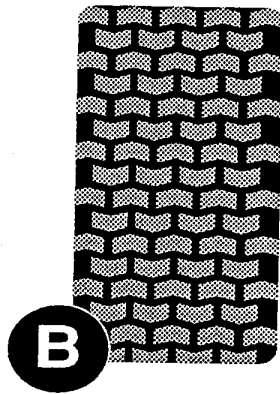
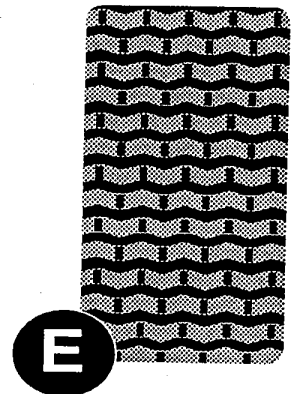
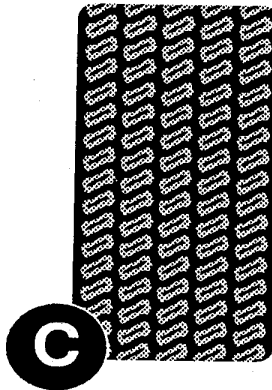
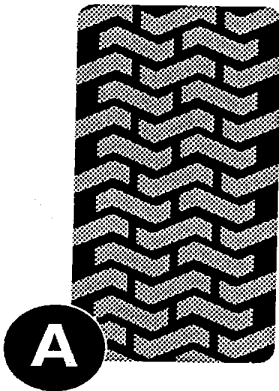

TIRE SIZE	"A"	"B"	"C"	"D"	"E"
11 X 4.00 - 5	42295	319679			
13 X 5.00 - 6	41060	319680			
15 X 6.00 - 6	39830	316702	301140	313952	
16 X 4.80 - 8		305035			
16 X 6.50 - 8	41081	319682		314539	
18 X 6.50 - 8		42091			
18 X 8.50 - 8	319683	317400			
18 X 9.50 - 8	41106	316701		313950	
20 X 8.00 - 8	319685	319684	57164	314584	331606
20 X 10.00 - 8	58276	319686		313654	
20 X 10.00 - 10	55893	319687			
23 X 9.50 - 12	53655	319690	319689	314370	

Contact the dealer where your tractor was purchased for the available accessories. If you are unable to contact the dealer, write to the address on the front cover of this manual.

Standard Lawn Tractor

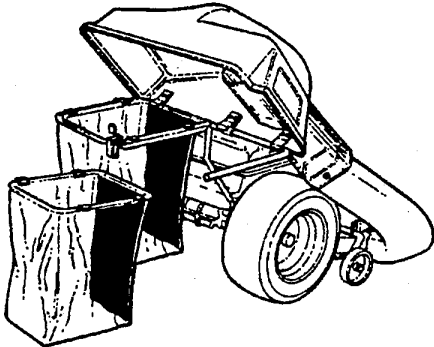

Model # 5708-13
Grass Collector for 39" decks
 For heavy duty grass collection
 order Model # 5709-10 Air Assist

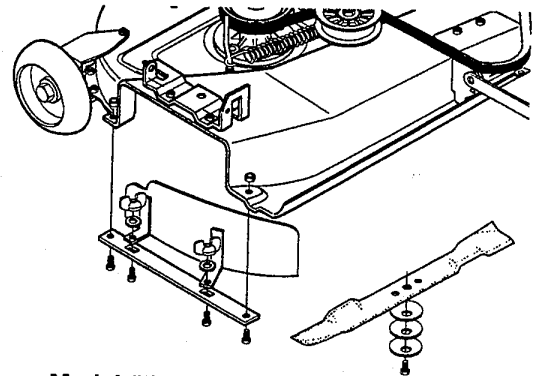

Model #5715-00
Mulching Kit (39" Deck)

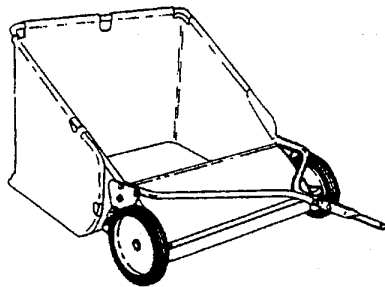

Model # 5648-16
Tow behind Lawn Sweeper for
Grass and leaves

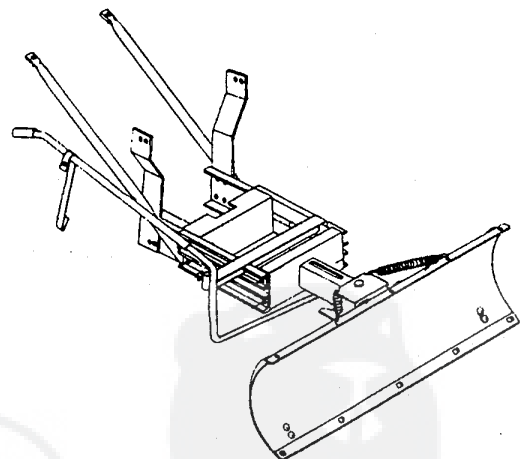

Model #5661-09
42" Snowblade - Fits 36", 38", 39", & 45"

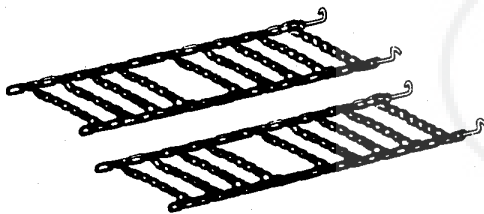

Model # 5579-00
Tire Chains - 18" x 8.50" tires

OTHER ACCESSORIES

Model	Description
5672-01	Wheel Weights - Front - 1 pr. w/mtg. hdw. - Fits 15" tires
5673-02	Wheel Weights - Rear - 1 pr. w/mtg. hdw. - Fits 18" & 20" tires
306932	39" High lift blade for bagging or side discharge (requires 2)
326160	39" Mulching blade (requires 2)