

EUROGARDEN

PARTS MANUAL

Lawn Tractors



Model E3554-290

GARDENSTAR 1030



SAFETY RULES

THESE INSTRUCTIONS ARE FOR YOUR PROTECTION. PLEASE READ THEM CAREFULLY.



IMPORTANT

THIS CUTTING MACHINE IS CAPABLE OF AMPUTATING HANDS AND FEET AND THROWING OBJECTS. FAILURE TO OBSERVE THE FOLLOWING SAFETY INSTRUCTIONS COULD RESULT IN SERIOUS INJURY OR DEATH.

I. GENERAL OPERATION:

- Know controls and how to stop quickly.
- Read, understand, and follow all instructions in the manual and on the machine before starting.
- Only allow responsible adults, who are familiar with instructions, to operate the machine.
- Wear safety glasses or eye shields when assembling or operating the machine.
- Do not operate machine when barefooted. Always wear substantial footwear, preferably steel-toed shoes.
- Do not wear loose fitting clothing that could get caught in moving parts.
- Clear the area of objects such as rocks, toys, wire, etc., which could be picked up and thrown by the blade(s).
- Be sure the area is clear of other people before mowing. Stop machine if anyone enters the area.
- Never carry passengers.
- Do not mow in reverse unless absolutely necessary. Always look down and behind before and while backing.
- Be aware of the mower discharge direction and do not point it at anyone. Do not operate the mower without either the entire grass catcher or the guard in place.
- Slow down before turning.
- Never leave a running machine unattended. Always turn off blades, set parking brake, stop engine, and remove keys before dismounting.
- Turn off blade(s) when not mowing.
- Stop engine before removing grass catcher or unclogging chute.
- Mow only in daylight or good artificial light.
- Do not operate the machine while under the influence of alcohol or drugs.
- Watch for traffic when operating near or crossing roadways.
- Use care when mowing around a fixed object to prevent the blade(s) from striking it. Never deliberately run over any foreign object.
- Use extra care when loading or unloading the machine into a trailer or truck.
- Use care when pulling loads or using heavy equipment.
 - a. Use only approved drawbar hitch points.
 - b. Limit loads to those that you can safely control.
 - c. Do not turn sharply. Use care when backing.
 - d. Use counterweight(s), wheel weight or tire chains when suggested in attachment(s) instructions.

II. SLOPE OPERATION:

Slopes are a major factor related to loss-of-control and tip-over accidents, which can result in severe injury or death. *All slopes require extra caution.* If you cannot back up the slope or if you feel uneasy on it, do not mow it.

DO

- Mow up and down slopes, not across.
- Remove obstacles such as rocks, tree limbs, etc.
- Watch for holes, ruts, or bumps. Uneven terrain could overturn the machine. *Tall grass can hide obstacles.*
- Use slow speed. Choose a low gear so that you will not have to stop or shift while on the slope.
- Follow the manufacturer's recommendations for wheel weights or counterweights to improve stability.
- Use extra care with grass catchers or other attachments. These can change the stability of the machine.
- Keep all movement on the slopes *slow* and *gradual*. Do not make sudden changes in speed or direction.
- Avoid starting or stopping on a slope. If tires lose traction, turn off the blade(s) and proceed slowly *straight* down the slope.

DO NOT

- Do not turn on slopes unless necessary, and then slowly and gradually downhill, if possible.
- Do not mow near drop-offs, ditches or embankments. The

mower could suddenly turn over if a wheel is over the edge of a cliff or ditch, or if an edge caves in.

- Do not mow on wet grass. Reduced traction could cause sliding.
- Do not try to stabilize the machine by putting your foot on the ground.
- Do not use grass catcher on steep slopes.

III. CHILDREN:

Tragic accidents can occur if the operator is not alert to the presence of children. Children are often attracted to the machine and the mowing activity. *Never* assume that children will remain where you last saw them.

- Keep children out of the mowing area and under the watchful care of another responsible adult.
- Be alert and turn machine off if children enter the area.
- Before and when backing, look behind and *down* for small children.
- Never carry children. They may fall off and be seriously injured or interfere with safe machine operation.
- Never allow children to operate the machine.
- Use extra care when approaching blind corners, shrubs, trees, or other objects that may obscure vision.

IV. SERVICE:

- Use extra care in handling gasoline and other fuels. They are flammable and vapors are explosive.
 - a. Use only an approved container.
 - b. Never remove gas cap or add fuel with the engine running. Allow engine to cool before refueling. Do not smoke.
 - c. Never refuel the machine indoors.
 - d. Never store the machine or fuel container inside where there is an open flame, such as in a water heater.
- Check fuel supply before each use allowing space for expansion as the heat of the engine and/or sun can cause gasoline to expand and overflow the tank.
- Use extra care when handling battery acid. Acid contact with skin may cause severe burns. Eye contact may cause blindness.
- Use extra care when servicing the battery. Explosive gas is produced in the battery. Do not service the battery while smoking or near an open spark or flame. This may cause the battery to explode causing serious injury.
- Never run a machine inside a closed area. Exhaust fumes contain CARBON MONOXIDE, an ODORLESS and DEADLY GAS.
- Keep nuts and bolts, especially blade attachment bolts, tight and keep equipment in good condition.
- Never tamper with safety devices. Check their operation regularly.
- Do not change the engine governor settings or overspeed engine.
- Reduce fire hazards. Keep machine free of grass, leaves, or other debris build-up. Clean up oil or fuel spillage. Allow machine to cool before storing.
- Stop and inspect the equipment if you strike an object. Repair, if necessary, before restarting.
- Never make adjustments or repairs with the engine running.
- Grass catcher components are subject to wear, damage, and deterioration, which could expose moving parts or allow objects to be thrown. Frequently check components and replace with manufacturer's recommended parts, when necessary.
- Mower blade(s) are sharp and can cut. Wrap the blade(s) or wear gloves, and use extra caution when servicing them.
- Check brake operation frequently. Adjust and service as required.



LOOK FOR THIS SYMBOL TO POINT OUT IMPORTANT SAFETY PRECAUTIONS. IT MEANS-- ATTENTION!!! BECOME ALERT!!! YOUR SAFETY IS INVOLVED.

Record the following information about your unit so that you will be able to provide it in case of loss or theft.

MODEL NUMBER: - (Enter complete 8 digit number from model plate on unit)

PURCHASE DATE: ___ / ___ / ___ CODE NO.: _____ SERIAL NO.: _____

DEALER'S NAME AND ADDRESS: _____

CITY: _____ STATE: _____ TELEPHONE: _____

TOOLS REQUIRED FOR ASSEMBLY

- 2 - 7/16 inch Wrenches (or adjustable wrench)
- 1 - 1/2 inch Wrench (or adjustable wrench)
- 1 - Small Phillips Screwdriver with a 1/4 inch shank
- 1 - Hammer

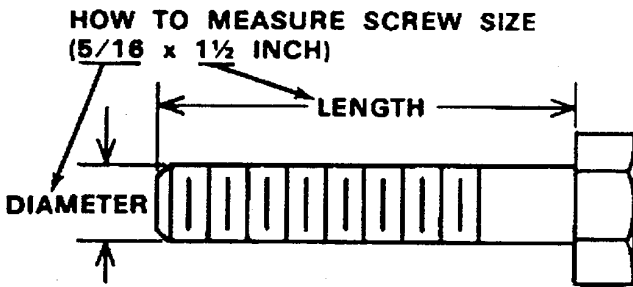

DANGER



This lawn tractor can be dangerous if carelessly used.

Read your Operator's Manual thoroughly before operating your lawn tractor.

Always wear safety glasses or eye shields while assembling or operating your lawn tractor.

DO NOT carry passengers at any time.

Keep your hands, feet, hair and loose clothing away from the discharge area, the underside of the mower deck or any moving parts while the engine is running.

DO NOT allow children or young teenagers to operate or be near your lawn tractor while it is operating.

ALWAYS GIVE THE FOLLOWING INFORMATION WHEN ORDERING REPAIR PARTS:
1. The PART NUMBER; 2. The PART NAME; 3. QUANTITY DESIRED; 4. The MODEL NUMBER (As shown on Model Plate).
SEND PART ORDERS AS PER INSTRUCTIONS ON THE FRONT PAGE.

DO NOT USE KEY NUMBERS WHEN ORDERING REPAIR PARTS, ALWAYS USE PART NUMBERS.

All replacement parts will be supplied in current production colors or in a neutral color.

A handling fee is applicable to small parts orders.

YOUR UNIT IS RIGHT HAND (RH) OR LEFT HAND (LH) AS YOU STAND BEHIND IT.

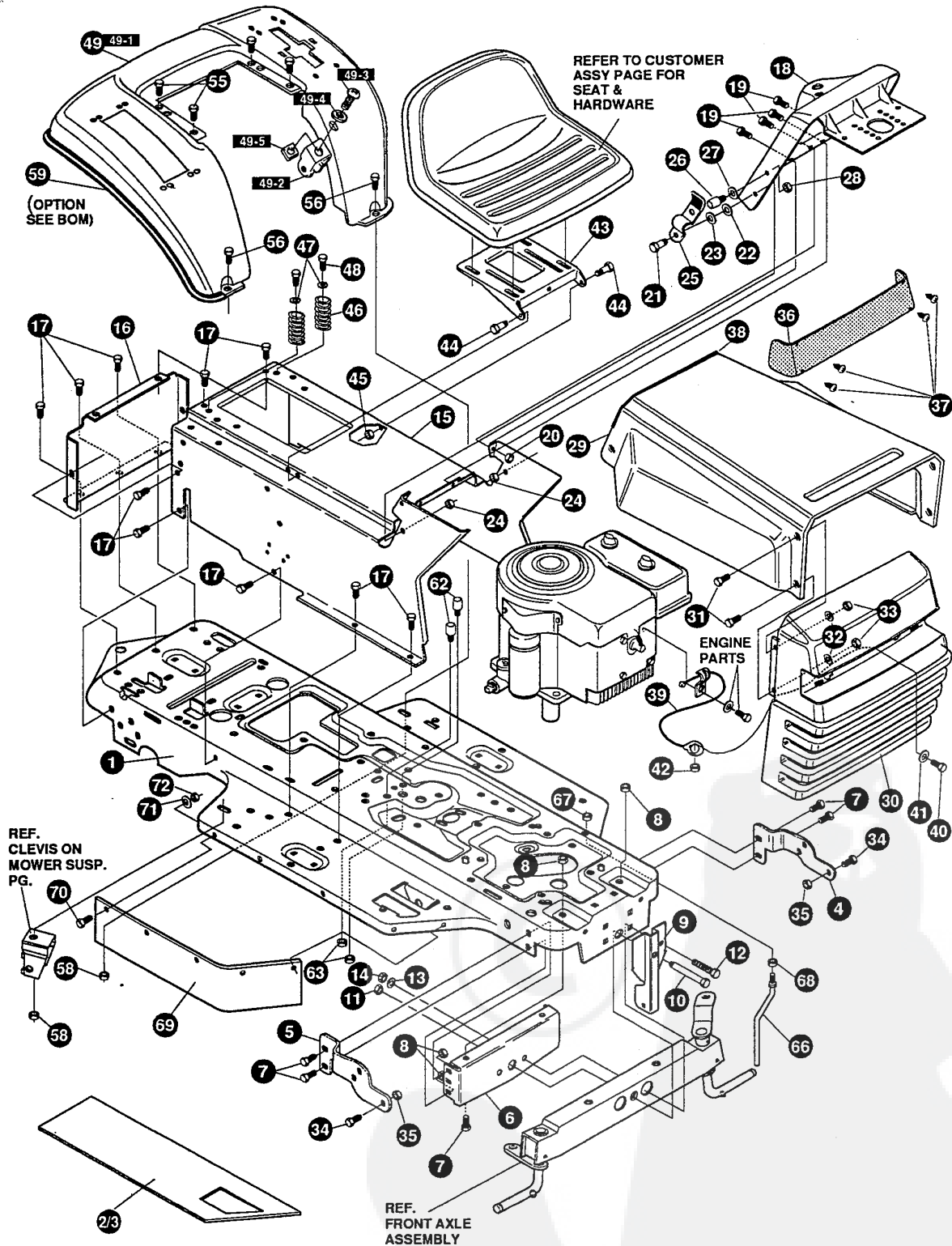

NOTE: ALWAYS USE ORIGINAL EQUIPMENT PARTS. Use of service/replacement parts other than original equipment parts may void your warranty.

ALL UNNUMBERED ITEMS ARE INTERCHANGEABLE WITH OPPOSITE SIDE

332593 A

KEY#	PART#	DESCRIPTION	QTY
1	332319-854	MAIN FRAME, RIDER TUV	1
2	331834	FOOT PAD, RH FULL WIDTH	1
3	331835	FOOT PAD, LH FULL WIDTH	1
4	314579-853	BRACKET,GRILLE LH	1
5	314578-853	BRACKET,GRILLE RH	1
6	56362-853	BRKT,SUPPORT,FRONT AXLE	1
7	328154	SCREW, 5/16-18X1.0WDFLLK	6
8	55273	NUT, 5/16-18 HXWDFLLK	6
9	321136-854	BRACKET, HANGER 30"	1
10	50720	BOLT, .625X2.875 SPSH 1/2-20	1
11	274654	NUT, 1/2-20 REGHXCTRLK	1
12	180138	SCREW, 3/8-16X3.00 HHC	4
13	2483	WASHER, .39IDX1.25DX.07 BELLVIL	4
14	1499	NUT, 3/8-16 REGHXCTRLK	4
15	324748-854	CONSOLE,FENDER SHFT	1
16	56235-854	CONSOLE, REAR COVER	1
17	995346	SCREW, 1/4-20X .50 WAHHTAP	15
18	320466-854	DASH	1
19	995338	SCREW, 1/4-20X .63 WAHHTAP	4
20	50352	NUT, 1/4-20 WDFLLK TOPLOCK	2
21	8482	BOLT, .375X .156 HSH 5/16-18	2
22	120394	WASHER, FLAT .406X .81X.065	2
23	120393	WASHER, FLAT .344X .69X.065	2
24	1498	NUT, 5/16-18 REGHEXCTRLK	2
25	57159	LATCH, .94WDX.047 ASSY HOOD	2
26	53446	PIN, 5/16-18 HOOD LATCH	2
27	138538	WASHER, REGINTLK.320X.61X.03	2
28	45174	NUT, 5/16-18 HEXWDFLLK WHIZ	2
29	314538-854	HOOD SF	1
30	325401	GRILLE	1
31	274672	SCREW, 1/4-20X .63 WAHHC	4
32	120392	WASHER, FLAT .281X .63X.065	4
33	1502	NUT, 1/4-20 REGHEXCTRLK	4
34	36149	BOLT, .375X .500 HSH 5/16-18	2
35	1498	NUT, 5/16-18 REGHEXCTRLK	2
36	302333	LENS, SMOKED W/TAB NO LOGO	1
37	57796	SCREW, #6 X .50 PLASTITE/HI-LO	4
38	56304	EDGING (78"-47453) WIDE BLK	25 IN.
39	311094	LANYARD,HOOD 11.75LG H15 VANG	1
40	180020	SCREW, 1/4-20X .75 HHC	1
41	120392	WASHER, FLAT .281X .63X.065	1
42	1502	NUT, 1/4-20 REGHEXCTRLK	1
43	58367-853	PLATE,SEAT	1
44	20507	BOLT, .437X .156 HSH 5/16-18	2
45	1498	NUT, 5/16-18 REGHEXCTRLK	2
46	330463	SPRING, SEAT 1.50ODX2.25LG	2
47	120392	WASHER, FLAT .281X .63X.065	2
48	995346	SCREW, 1/4-20X .50 WAHHTAP	2
49	^	ASSEMBLY, FENDER	1
49-1	332423-854	FENDER	1
49-2	9239	CLEVIS	1
42-3	439455	SCREW, 5/16-18X .56PHPNMA BKPH	1
42-4	301551	WASHER, .344IDX1.50DX.09 CU ZN	1
42-5	120373	NUT, 5/16-18 SQ	1
55	995346	SCREW, 1/4-20X .50 WAHHTAP	4
56	126358	BOLT, 5/16-18X1.00 CARR	2
58	55273	NUT, 5/16-18 HXWDFLLK	2
59	55023	TRIM, 77.5" BLACK NARROW	77.5
62	53446	PIN, 5/16-18 HOOD LATCH	2
63	271184	NUT, 5/16-18 HEXKEPS	2
66	50653	GUIDE, BELT	1
67	41529	NUT, 3/8-16 HXCTRLKJAM	1
68	271190	NUT, 3/8-16 HEXKEPS	1
69	305395	BELT GUARD SF RUBBER 7 X 25.46	2
70	57034	SCREW, 10-24X .63 TRHMA	12
71	1501	WASHER, FLAT .203X .56X.040	12
72	271166	NUT, #10-24 HEXKEPS	12
73	333198	PARTS MANUAL	1
74	333228	OPERATOR'S MANUAL (GERMAN)	1
75	323000	GRASS CATCHER MANUAL (ENGLISH)	1
76	323207	GRASS CATCHER MANUAL (FRENCH)	1

^ ORDER INDIVIDUAL PARTS

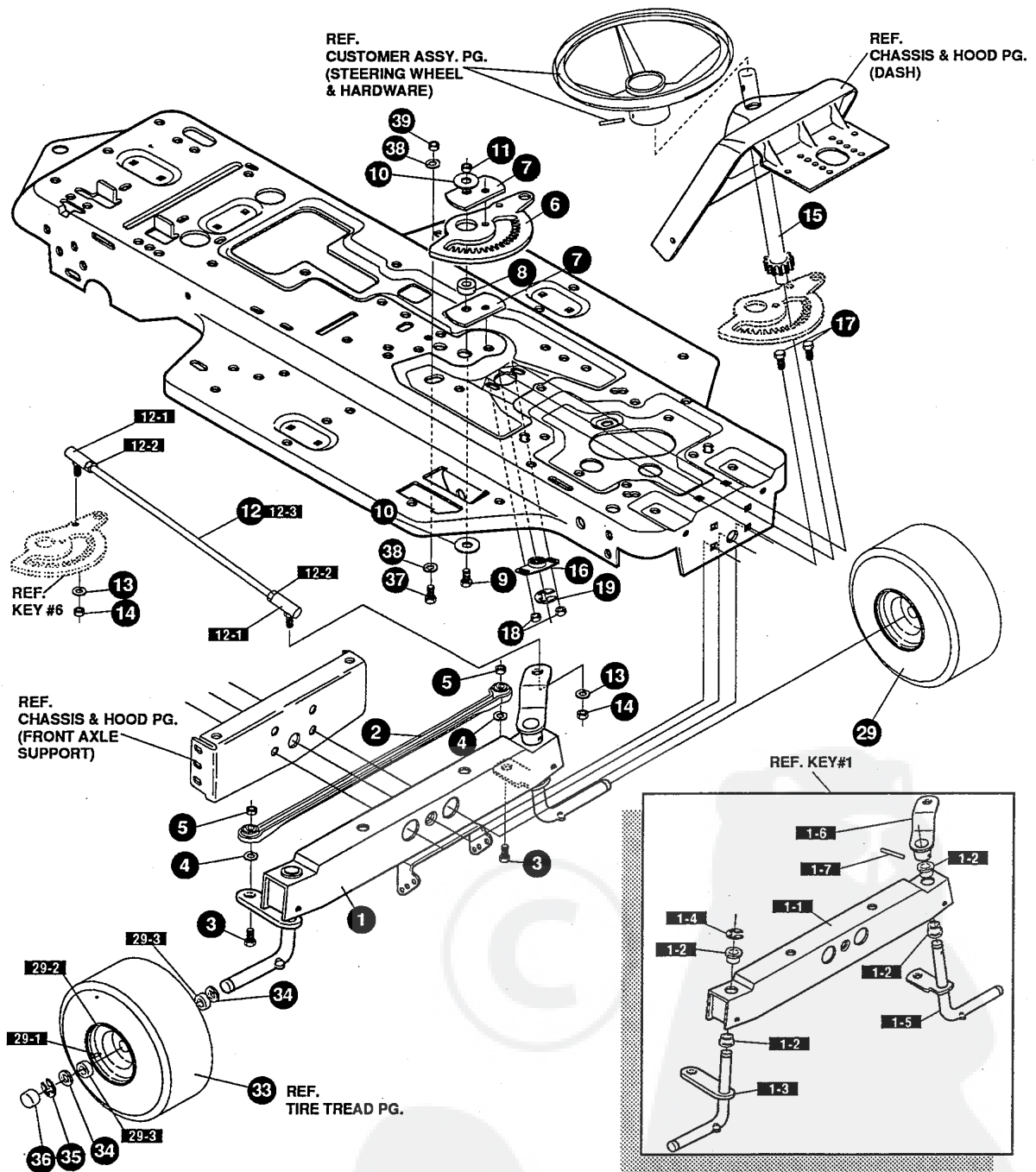

NOTE: ALWAYS USE ORIGINAL EQUIPMENT PARTS. Use of service/replacement parts other than original equipment parts may void your warranty.

ALL UNNUMBERED ITEMS ARE INTERCHANGEABLE WITH OPPOSITE SIDE

326426 G

KEY#	PART#	DESCRIPTION	QTY
1	^	AXLE FRONT ASSY, LONG	1
1-1	312280	FRONT AXLE, ASSY	1
1-2	50546	BRNG, FL .759IDX1.002ODX .75	4
1-3	310368	SPINDLE,ASSY,RH LONG	1
1-4	36625	RING, RETEX .57X.05TRU5133-75	1
1-5	310367	SPINDLE,ASSY,LH LONG	1
1-6	327619-853	ARM ASSY 4WS FRNT STRNG	1
1-7	454565	PIN, SPRING.250DIA X1.25LG HVPL.....	1
2	302688	SF ASSY,TIE ROD 19.31 LG	1
3	180124	SCREW, 3/8-16X1.25 HHC	2
4	120382	WASHER, REGSPTLK.393X.68X.10	2
5	1499	NUT, 3/8-16 REGHXCTRLK	2
6	324752	GEAR, SECTOR HT	1
7	330789	PLATE, SECT 4WS	2
8	330021	BUSHING, SECTOR GEAR 4WS	1
9	181643	SCREW, 3/8-24X1.50 HHC	1
10	845	WASHER, FLAT .390X1.25X.119	2
11	412349	NUT, 3/8-24 HXCTRLK	1
12	328808	DRAG LINK ASSY 17.69LG	1
12-1	57158	BALL JOINT 3/8 THD SHORT STUD	2
12-2	124925	NUT, 3/8-24 REGHEXJAM	2
12-3	56190	DRAG LINK	1
13	120382	WASHER, REGSPTLK.393X.68X.10	2
14	120369	NUT, 3/8-24 REGHEX	2
15	327834	LF SHAFT, PIN-STEER BLK	1
16	325692	BRNG, FL .50 IDX1.370ODX	1
17	326505	SCREW, 1/4-20X.75 (TQ 30-35 FT#)	2
18	46931	NUT, 1/4-20 WDFL MAC-LOCK	2
19	20864	RING, RET E .39X.04TRU5133-50	1
29	41059	TIRE & RIM, PU 13X5.0X6 TUR.....	2
29-1	24167	VALVE STEM	
29-2	39937	RIM, WHEEL	
29-3	314416	BEARING, FL	
33		REFER TO TIRE TREAD PAGE	
34	642	WASHER, FLAT .755X1.31X.075	4
35	36625	RING, RETEX .57X.05TRU5133-75	2
36	40394	HUB CAP, 1.500ID X 7/8LG	2
37	180124	SCREW, 3/8-16X1.25 HHC	1
38	120394	WASHER, FLAT .406X .81X.065	2
39	45171	NUT, 3/8-16 HWDFL WHIZ-LOCK	1

^ ORDER INDIVIDUAL PARTS

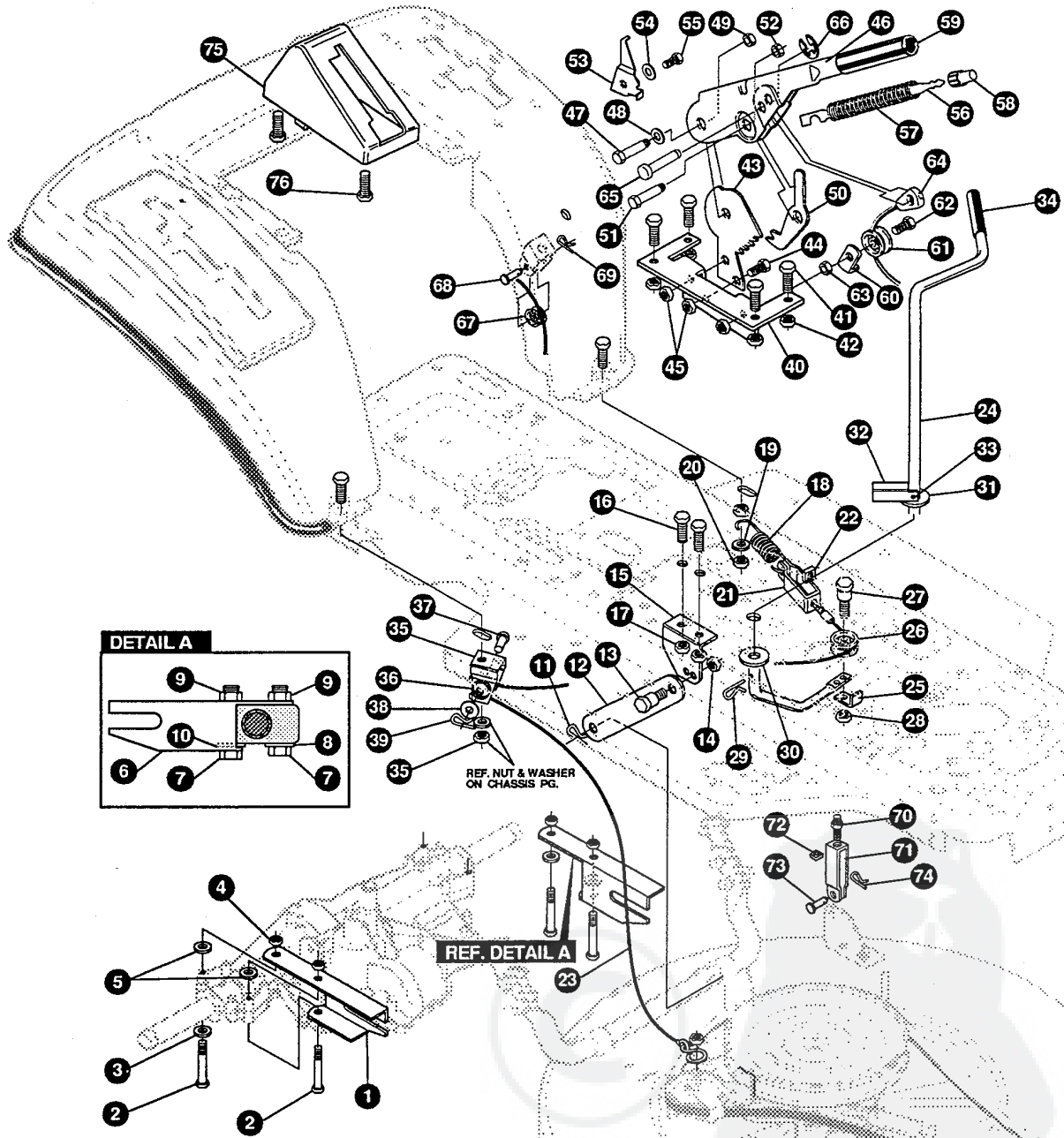

NOTE: ALWAYS USE ORIGINAL EQUIPMENT PARTS. Use of service/replacement parts other than original equipment parts may void your warranty.

ALL UNNUMBERED ITEMS ARE INTERCHANGEABLE WITH OPPOSITE SIDE

331231 A

E3554-290

MOWER SUSPENSION ASSEMBLY

KEY#	PART#	DESCRIPTION	QTY
1	321371	BRACKET, REAR SUPT RH	1
2	180113	SCREW, 5/16-18X3.00 HHC	2
3	120393	WASHER, FLAT .344X.69X.065	1
4	1498	NUT, 5/16-18 REGHEXCTRLK	2
5	314702	SPACER, SLEV .344X1.00X .500PM	2
6	321370	BRACKET, REAR SUPT LH	1
7	180113	SCREW, 5/16-18X3.00 HHC	2
8	120393	WASHER, FLAT .344X.69X.065	1
9	1498	NUT, 5/16-18 REGHEXCTRLK	2
10	314702	SPACER, SLEV .344X1.00X .500PM	1
11	56180	PIN, HAIR .091 DIA X 1.62LG	1
12	323899	BRACKET, LINK LOWER BLK	1
13	313560	BOLT, .500X .225 HHSH 5/16-18	1
14	1498	NUT, 5/16-18 REGHEXCTRLK	1
15	320605-853	BRACKET, LIFT BAR 30"	1
16	180077	SCREW, 5/16-18X .75 HHC	2
17	1498	NUT, 5/16-18 REGHEXCTRLK	2
18	300473	SPRING, TENSION 7.52LG+17LB/IN	1
19	418924	WASHER, FLAT .344X1.13X.062	1
20	1498	NUT, 5/16-18 REGHEXCTRLK	1
21	9405	CLEVIS, LIFT CABLE	1
22	120372	NUT, 1/4-20 REGSQ	1
23	322261	CABLE, CLUTCH 31.31 LG (30"SF)	1
24	314877	LEVER, CLUTCH SF 30" SUS ZINC	1
25	1288	LF BRKT, CABLE RETAIN	1
26	48306	PULLEY, POWDER METAL	1
27	58336	BOLT, .375X .375 HHSH 1/4-20	1
28	1502	NUT, 1/4-20 REGHEXCTRLK	1
29	8260	PIN, HAIR .091 DIA X 1.66LG	1
30	996425	WASHER, FLAT .515X .88X.064	1
31	22265	WASHER, FLAT .515X1.38X.119PL	1
32	305225	STOP, PTO ENGAGE	1
33	326386	PIN, SPRING.187DIA X 1.13LG HD	1
34	55514	KNOB, ROUND 1.50DIA OR GRIP SF	1
35	321295-853	CLEVIS, P.T.O. PULLY	1
36	48306	PULLEY, POWDER METAL	1
37	300317	PIN, CLEVIS .375DIA X .81 LG	1
38	996416	WASHER, FLAT .391X1.00X.125	1
39	8260	PIN, HAIR .091 DIA X 1.66LG	1
40	313926	BRACKET, HGT/ADJUST SUPPORT	1
41	180077	SCREW, 5/16-18X .75 HHC	4
42	1498	NUT, 5/16-18 REGHEXCTRLK	4
43	301238	QUADRANT, HEIGHT ADJUST	1
44	180077	SCREW, 5/16-18X .75 HHC	2
45	1498	NUT, 5/16-18 REGHEXCTRLK	2
46	322292-853	HANDLE, LIFT SHORT(30" S.F.)	1
47	300171	BOLT, .500X .270 HHSH 5/16-18	1
48	996418	WASHER, FLAT .506X .75X.024	1
49	44108	NUT, 5/16-18 HWDFLCTRLK	1
50	301239	PAWL, SQUARE	1
51	300171	BOLT, .500X .270 HHSH 5/16-18	1
52	44108	NUT, 5/16-18 HWDFLCTRLK	1
53	9435	POINTER, HEIGHT ADJ	1
54	138479	WASHER, EXLK .195X.41X.03	1
55	35287	SCREW, #8-32X .38 HHWATAP	1
56	303027	ROD, ACTUATOR-SHORT	1
57	58326	SPRING, HEIGHT ADJUST	1
58	58325	KNOB, HEIGHT ADJ PUSH BUTTON	1
59	58329	GRIP, .750 OD W/ HOLE BLACK	1
60	9149	LF BRKT, CABLE RETAIN	1
61	48306	PULLEY, POWDER METAL	1
62	58336	BOLT, .375X .375 HHSH 1/4-20	1
63	1502	NUT, 1/4-20 REGHEXCTRLK	1
64	321430	CABLE, LIFT 21.50 - 30"	1
65	300310	PIN, CLEVIS .310DIA+.475LG	1
66	300311	RING, RET E .31X.25TRUX5133-31	1
67	48306	PULLEY, POWDER METAL	1
68	300317	PIN, CLEVIS .375DIA X .81 LG	1
69	8260	PIN, HAIR .091 DIA X 1.66LG	1
70	120375	NUT, 1/4-20 REGHEX	1
71	9405	LF CLEVIS, LIFT CABLE	1
72	120372	NUT, 1/4-20 REGSQ	1
73	39522	PIN, CLEVIS .312 X .812	1
74	121222	PIN, COTTER .090 DIA X .75LG	1
75	300335	LIFT COVER	1
76	300340	SCREW, #10 X .75 HHPLAST BLK	3

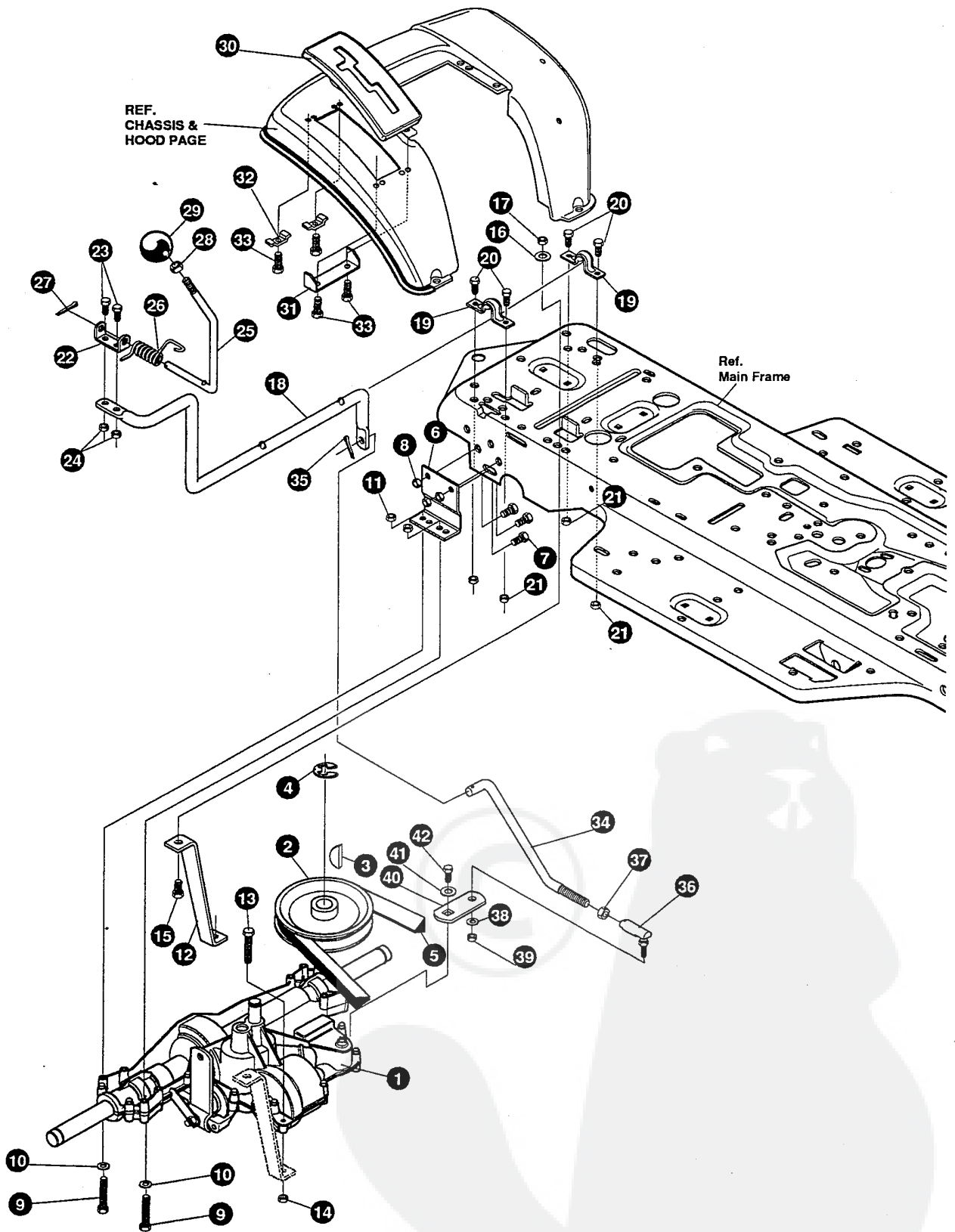

NOTE: ALWAYS USE ORIGINAL EQUIPMENT PARTS. Use of service/replacement parts other than original equipment parts may void your warranty.

ALL UNNUMBERED ITEMS ARE INTERCHANGEABLE WITH OPPOSITE SIDE

332252 B

KEY#	PART#	DESCRIPTION	QTY
1	^	TRANSAXLE 940-007 2WS,LF,SF	1
2	303109	PULLEY, 6.6 OD V4L T/A	1
3	50795	KEY, HI-PRO 606 .75DIA X.187WD	1
4	22053	RING, RETEX .58X.035TRU5100-62	1
5	54758	BELT, V 4L 82.00 SF DRIVE	1
6	53768-853	BRACKET,TRANSAXLE	2
7	180077	SCREW, 5/16-18X .75 HHC	6
8	1498	NUT, 5/16-18 REGHEXCTRLK	6
9	180091	SCREW, 5/16-18X2.50 HHC	4
10	120393	WASHER, FLAT .344X .69X.065	4
11	1498	NUT, 5/16-18 REGHEXCTRLK	4
12	323213	LF BRKT, T/A TORQ. BLK	1
13	180087	SCREW, 5/16-18X2.00 HHC	1
14	1498	NUT, 5/16-18 REGHEXCTRLK	1
15	180079	SCREW, 5/16-18X1.00 HHC	1
16	138485	WASHER, EXLK .320X.61X.03	1
17	1498	NUT, 5/16-18 REGHEXCTRLK	1
18	321849	LEVER, SHIFT LOW SF FNSFT 915	1
19	302760	CLAMP .625DIA	2
20	180077	SCREW, 5/16-18X .75 HHC	4
21	1498	NUT, 5/16-18 REGHEXCTRLK	4
22	310356	LF BRKT, PIVOT SH LEV	1
23	180020	SCREW, 1/4-20X .75 HHC	2
24	1502	NUT, 1/4-20 REGHEXCTRLK	2
25	309635	LEVER, SHIFT UPPER SOF 1/2-13	1
26	310265	SPRING, TORS. .56X.95X.095	1
27	137185	PIN, COTTER .125 DIA X1.00LG	1
28	331310	NUT, 1/2-13 HEXJAM	1
29	55514	KNOB, ROUND 1.50DIA OR GRIP SF	1
30	311209	COVER PLASTIC LF P930/F4360-6	1
31	311257-853	BRACKET COVER F-5 FNDR SHIFT	1
32	1341	LF CLAMP, SPRG 1.17"ID	2
33	311331	SCREW, 1/4-15X.44/.53 HILOHWA	4
34	321844	ROD, CONNECTING, SHIFT ZINC	1
35	137185	PIN, COTTER .125 DIA X1.00LG	1
36	57158	BALL JOINT 3/8 THD SHORT STUD	1
37	124925	NUT, 3/8-24 REGHEXJAM	1
38	120382	WASHER, REGSPTLK.393X.68X.10	1
39	120369	NUT, 3/8-24 REGHEX	1
40	323212	LF BRKT, SHIFT S/F BLK	1
41	57157	WASHER,.750X.250 SP-TRANSAXLE	1
42	56255	SCREW, 1/4-28X .75 NYLHHC	1

^ CONTACT YOUR NEAREST TRANSAXLE DEALER FOR PARTS AND SERVICE

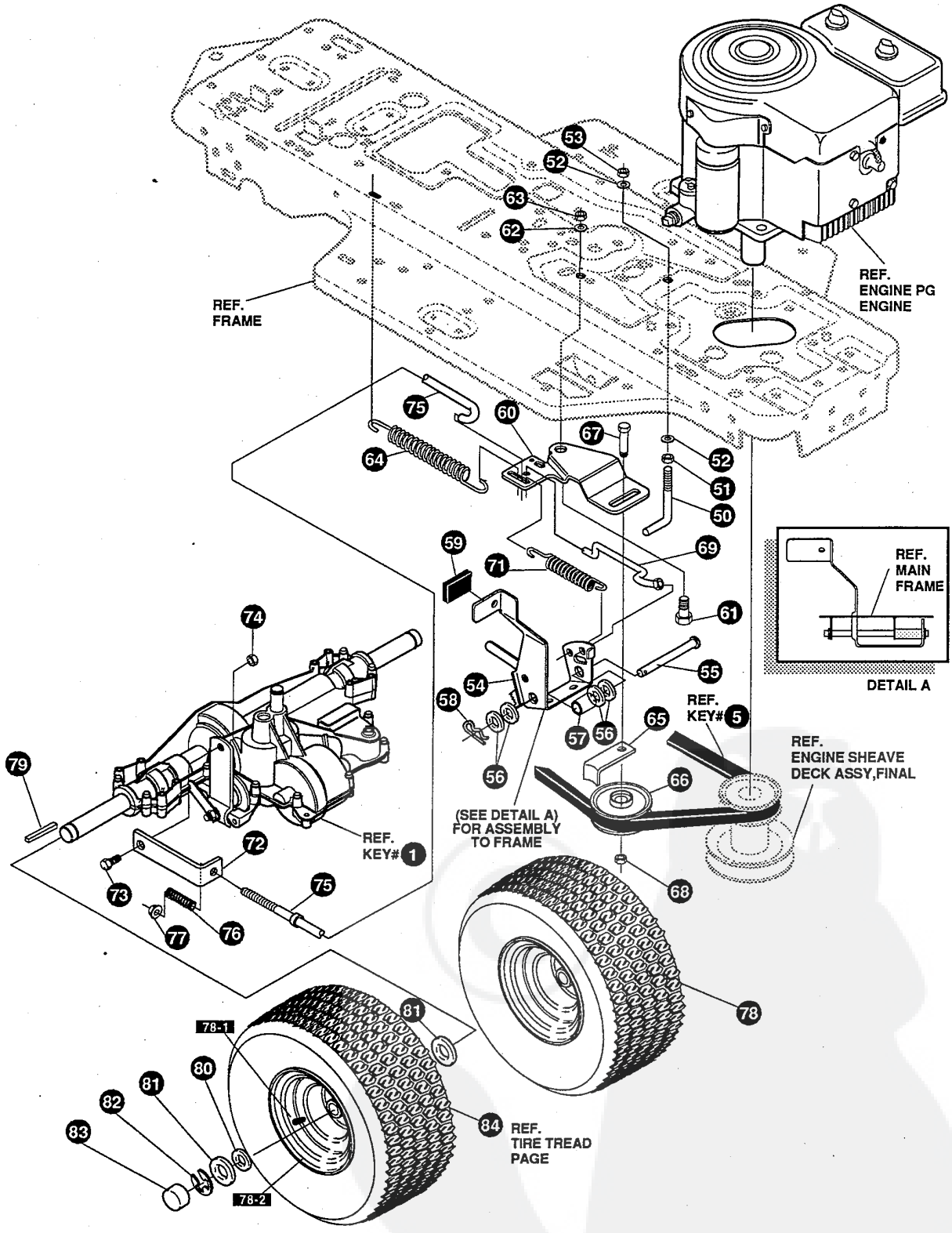

NOTE: ALWAYS USE ORIGINAL EQUIPMENT PARTS. Use of service/replacement parts other than original equipment parts may void your warranty.

ALL UNNUMBERED ITEMS ARE INTERCHANGEABLE WITH OPPOSITE SIDE

332252 B

E3554-290**MOTION DRIVE ASSEMBLY**

KEY#	PART#	DESCRIPTION	QTY
50	49896	BELT GUIDE	1
51	271184	NUT, 5/16-18 HEXKEPS	1
52	120393	WASHER, FLAT .344X .69X.065	2
53	1498	NUT, 5/16-18 REGHEXCTRLK	1
54	331836	ASSY, PEDAL, BRAKE, CLUTCH SF	1
55	319676	PIN, CLEVIS .500DX4.87LG	1
56	2968	WASHER, FLAT .504X .75X.059	4
57	331972	SPACER, SLEV .53 X .62X1.240	1
58	56180	PIN, HAIR .091 DIA X 1.62LG	1
59	48761	PAD, CLUTCH/BRAKE PEDAL	1
60	321969	IDLER ARM BRKT TRACTION SF	1
61	329989	BOLT, .625X .135 HSH 5/16-18	1
62	45602	WASHER, FLAT .333X .87X.119	1
63	1498	NUT, 5/16-18 REGHEXCTRLK	1
64	327867	SPRING, 3/4 ODX 7.75X.091 TENSION	1
65	39659	RETAINER, BELT	1
66	35374	PULLEY, IDLER V4L 3.06X .62	1
67	45892	BOLT, 3/8-16X1.50 CARRSN	1
68	1499	NUT, 3/8-16 REGHXCTRLK	1
69	333175	CLUTCH ROD ASSY, .268 DIA 3.92	1
71	326780	SPRING, 3/8ODX 2.18 X.055 TENSION	1
72	323210	LF BRKT, TRCTN S/F BLK	1
73	46824	BOLT, .500X .188 HSH 5/16-18	1
74	1498	NUT, 5/16-18 REGHEXCTRLK	1
75	323211	LF ROD, BRAKE 915 BLK	1
76	313881	CLUTCH SPRING	1
77	50352	NUT, 1/4-20 WDFLLK TOPLOCK	1
78	42090	TIRE & RIM, PU 18X6.5X8TURFWHI	2
78-1	24167	VALVE STEM	
78-2	36182	RIM, WHEEL	
79	52928	KEY, SQUARE .187SQX2.25LG	2
80	642	WASHER, FLAT .755X1.31X.075	4
81	42815	WASHER, FLAT .755X1.53X.07	2
82	36625	RING, RETEX .57X.05TRU5133-75	2
83	40394	HUB CAP, 1.500ID X 7/8LG	2
84		REFER TO TIRE TREAD PAGE	

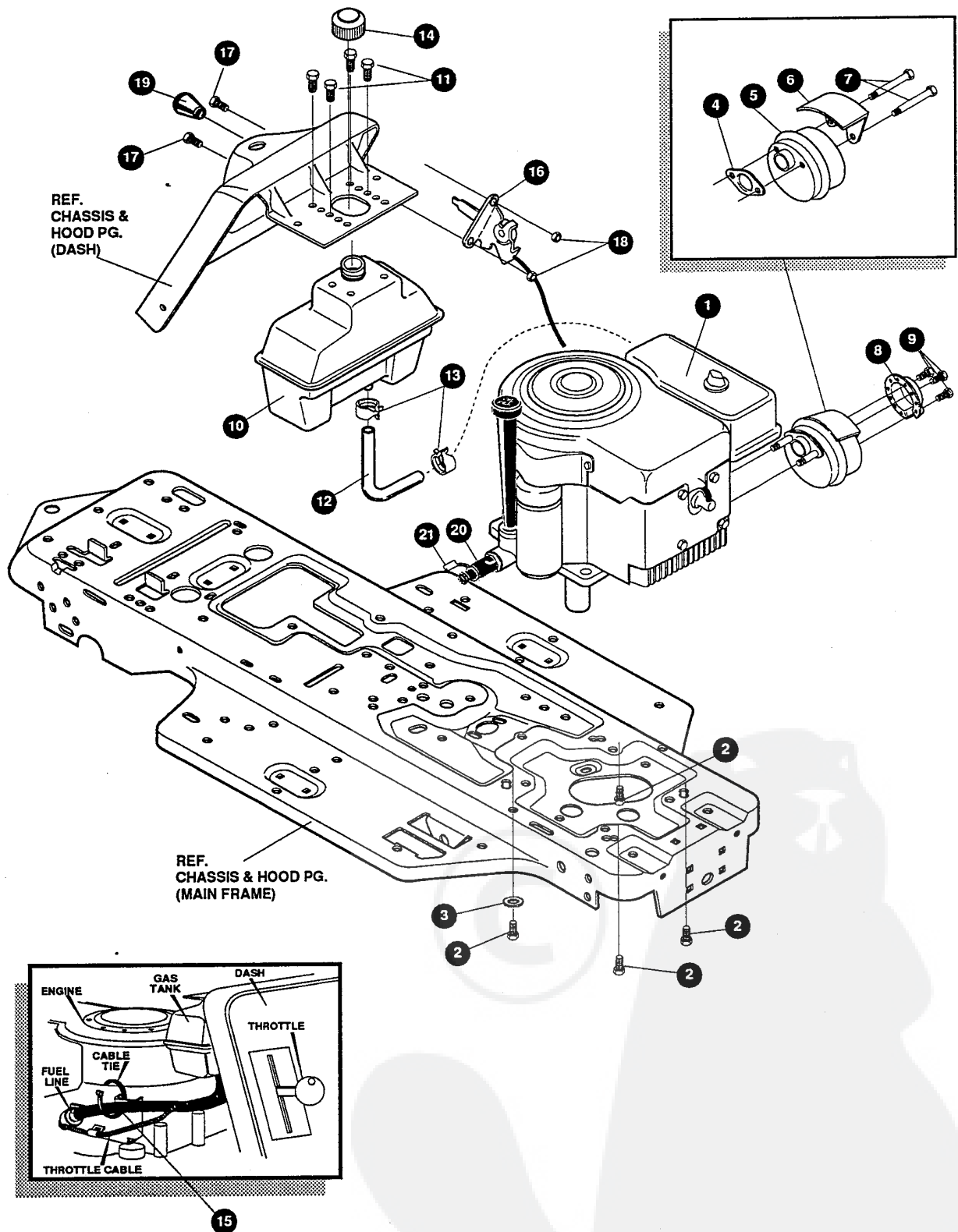

NOTE: ALWAYS USE ORIGINAL EQUIPMENT PARTS. Use of service/replacement parts other than original equipment parts may void your warranty.

ALL UNNUMBERED ITEMS ARE INTERCHANGEABLE WITH OPPOSITE SIDE

332431 A

KEY#	PART#	DESCRIPTION	QTY
1	ENGINE	10-12HP B&S 3A(SEE ENGINE MANUAL)	1
2	50947	SCREW, 3/8-16X1.25 WAHHTAPBLKP	4
3	138489	WASHER, EXLK .384X.69X.04	1
4	46708	GASKET, MUFFLER	1
5	57908	MUFFLER-DOM/EXP ROUND	1
6	54767	SHIELD, HEAT, FOR ROUND MUFFLER	1
7	54980	SCREW, 5/16-18X3.50 HHC	2
8	323423	DEFLECTOR, MUFFLER PARTIAL	1
9	35287	SCREW, #8-32X .38 HHWATAP	3
10	314989	TANK, FUEL 1 GAL CLEAR	1
11	300303	SCREW, .25X.75X.51HHWAPLASTITE	4
12	42258	TUBING, .25X.50X BULK GAS LINE	12.0
13	47345	CLAMP, HOSE SCREW TYPE	2
14	46704	CAP, GAS 1-1/2-7 THD BLK	1
15	57444	TIE, CABLE BLACK NYLON 5.62L	1
16	320031	THROTTLE CONTROL	1
17	274707	SCREW, 10-24X .50 WAHMA	2
18	308459	NUT, #10-24 HXHDNYLK	2
19	50607	KNOB, ROUND THROTTLE BLACK	1
20	325547	OIL DRAIN VALVE ASSEMBLY	1
21	327422	CAP, OIL DRAIN VALVE ASM. YELLOW	1

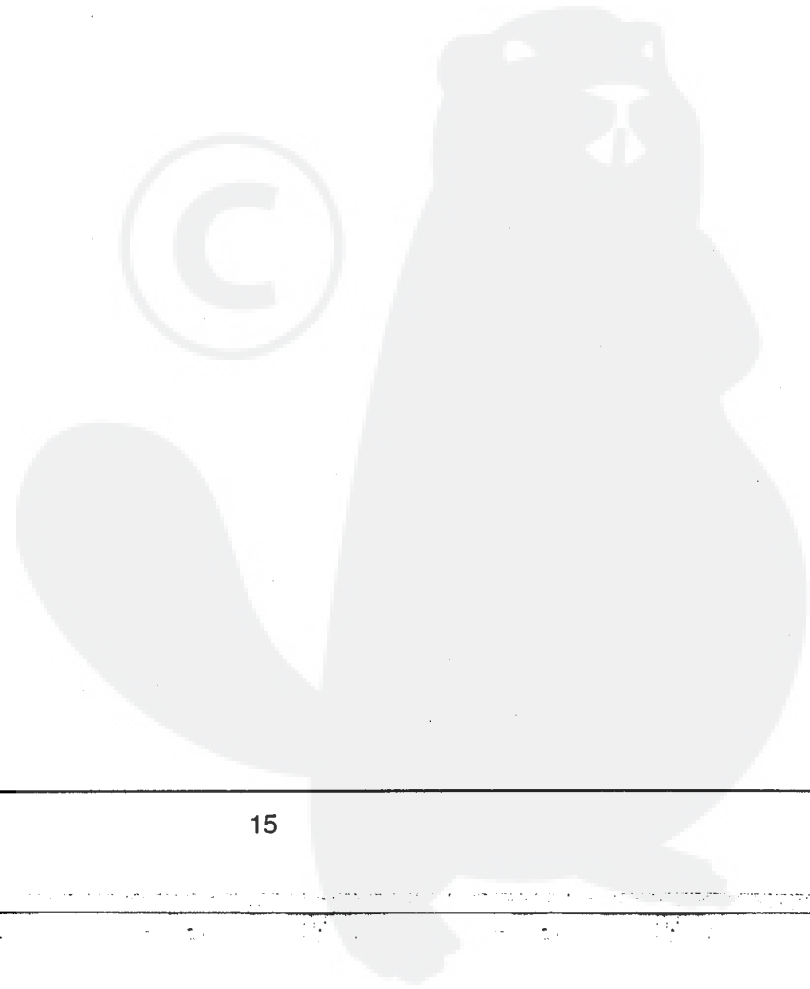

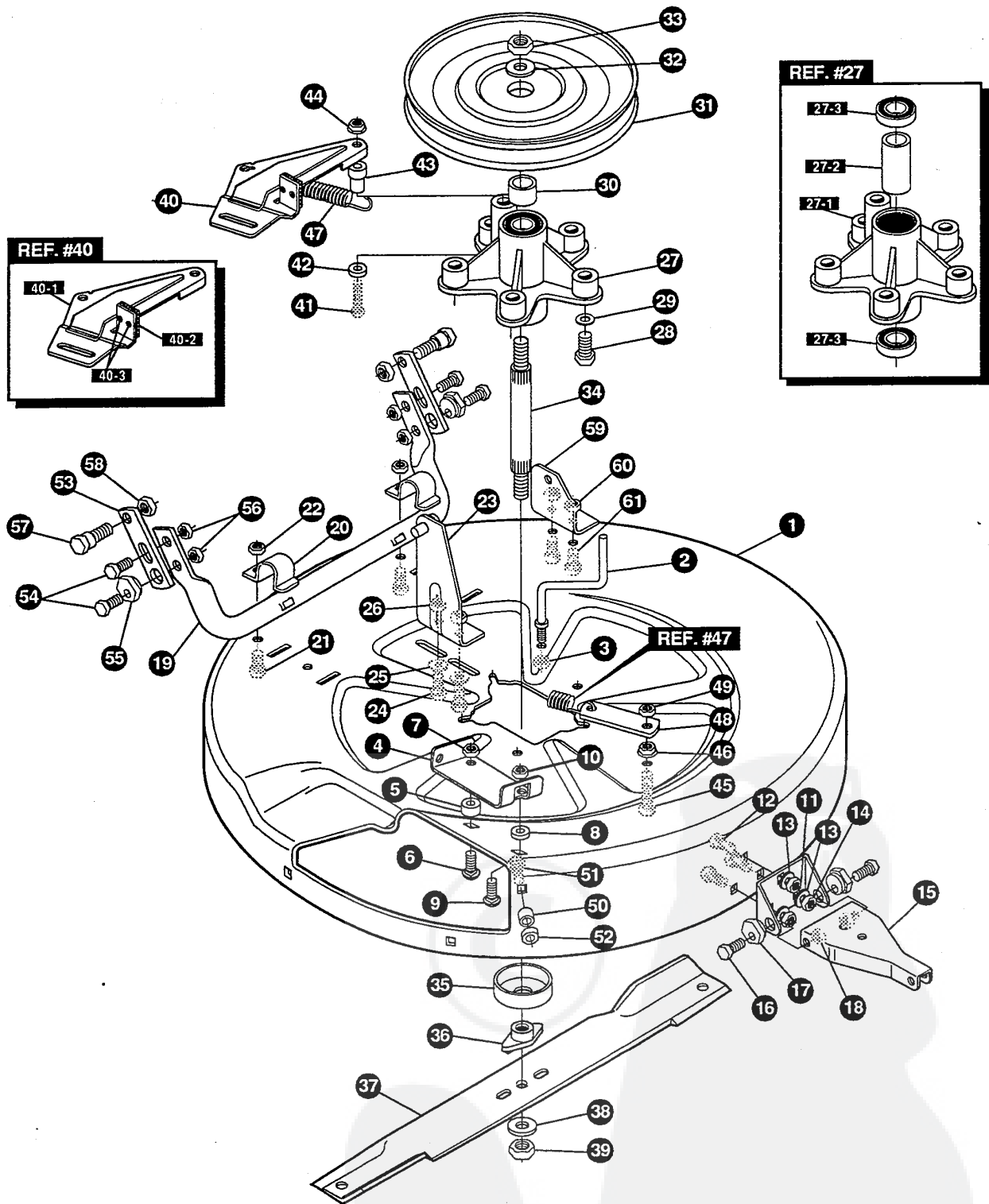

NOTE: ALWAYS USE ORIGINAL EQUIPMENT PARTS. Use of service/replacement parts other than original equipment parts may void your warranty.

ALL UNNUMBERED ITEMS ARE INTERCHANGEABLE WITH OPPOSITE SIDE

321244 C

E3554-290

PRE-PAINTED DECK ASSEMBLY

KEY#	PART#	DESCRIPTION	QTY
1	321982-853	DECK, MOWER 30" S.F./RER	1
2	57318	GUIDE, BELT 5/16-18 THD	1
3	1498	NUT, 5/16-18 REGHEXCTRLK	1
4	317017	BRACKET CHUTE MOUNT BLACK	1
5	314702	SPACER, SLEV .344X1.00X .500PM	1
6	120230	BOLT, 5/16-18X1.25 CARRLN	1
7	1498	NUT, 5/16-18 REGHEXCTRLK	1
8	45602	WASHER, FLAT .333X .87X.119	1
9	126216	BOLT, 5/16-18X .75 CARRLN	1
10	1498	NUT, 5/16-18 REGHEXCTRLK	1
11	311237-853	BRACKET, MOUNTING, FRONT	1
12	57072	BOLT, 5/16-18X .63 CARRLN	3
13	120393	WASHER, FLAT .344X .69X.065	3
14	1498	NUT, 5/16-18 REGHEXCTRLK	3
15	311236-853	BRACKET, BAR, TOW, FRONT	1
16	180079	SCREW, 5/16-18X1.00 HHC	2
17	58247	NUT, ADJUST	2
18	1498	NUT, 5/16-18 REGHEXCTRLK	2
19	313372-853	ASSY, TUBE, PIVOT	1
20	310672	SUPPORT,PIVOT TUBE BLK	2
21	180077	SCREW, 5/16-18X .75 HHC	2
22	1498	NUT, 5/16-18 REGHEXCTRLK	2
23	314119-853	ASSY LIFT BRKT.	1
24	180077	SCREW, 5/16-18X .75 HHC	2
25	120393	WASHER, FLAT .344X .69X.065	2
26	1498	NUT, 5/16-18 REGHEXCTRLK	2
27	313588	ASSEMBLY, QUILL	1
27-1	314272	QUILL, MACHINED CASTING	1
27-2	314274	TUBE, SPACER, STEEL	1
27-3	313576	BRNG, BALL 6204-2AA-C3	2
28	50634	SCREW, 5/16-18X .88 WAHHTAP	5
29	138485	WASHER, EXLK .320X.61X.03	5
30	321146	SPACER, SLEV .790X1.250X .500	1
31	314273	PULLEY ASSEMBLY	1
32	22265	WASHER, FLAT .515X1.38X.119PL	1
33	1500	NUT, 1/2-13 REGHCTRLK	1
34	321144	SHAFT, QUILL 30" MOWER - S.F.	1
35	313577	SHIELD, DUST, BEARING	1
36	313584	HUB, BLADE ADAPTOR	1
37	325751	BLADE, 30" TD 1.4 WING BLACK	1
38	22265	WASHER, FLAT .515X1.38X.119PL	1
39	1500	NUT, 1/2-13 REGHCTRLK	1
40	12229-853	BRACKET, IDLER ASSEMBLY	1
40-1	313510-853	BRACKET, ARM, IDLER	1
40-2	306973	BRAKE PAD - HARD - 232AF	1
40-3	41601	RIVET, OVSET .187DIA X .50LG ST	2
41	180113	SCREW, 5/16-18X3.00 HHC	1
42	45602	WASHER, FLAT .333X .87X.119	1
43	321145	SPACER, SLEV .322X .63X2.310	1
44	44108	NUT, 5/16-18 HWDFLCTRLK	1
45	122027	SCREW, 5/16-18X1.25 HHC	1
46	44108	NUT, 5/16-18 HWDFLCTRLK	1
47	35410	SPRING .071 X .62 X 4.37	1
48	302357	LINK	1
49	1498	NUT, 5/16-18 REGHEXCTRLK	1
50	50520	SPACER	1
51	126216	BOLT, 5/16-18X .75 CARRLN	1
52	1498	NUT, 5/16-18 REGHEXCTRLK	1
53	314099-853	BRACKET, BAR, REAR STABILI	2
54	180079	SCREW, 5/16-18X1.00 HHC	4
55	58247	NUT, ADJUST	2
56	1498	NUT, 5/16-18 REGHEXCTRLK	4
57	51940	BOLT, .500X .437 HHS 3/8-16	2
58	1499	NUT, 3/8-16 REGHXCTRLK	2
59	320605-853	BRACKET,LIFT BAR 30" SF	1
60	1498	NUT, 5/16-18 REGHEXCTRLK	2
61	180077	SCREW, 5/16-18X .75 HHC	2

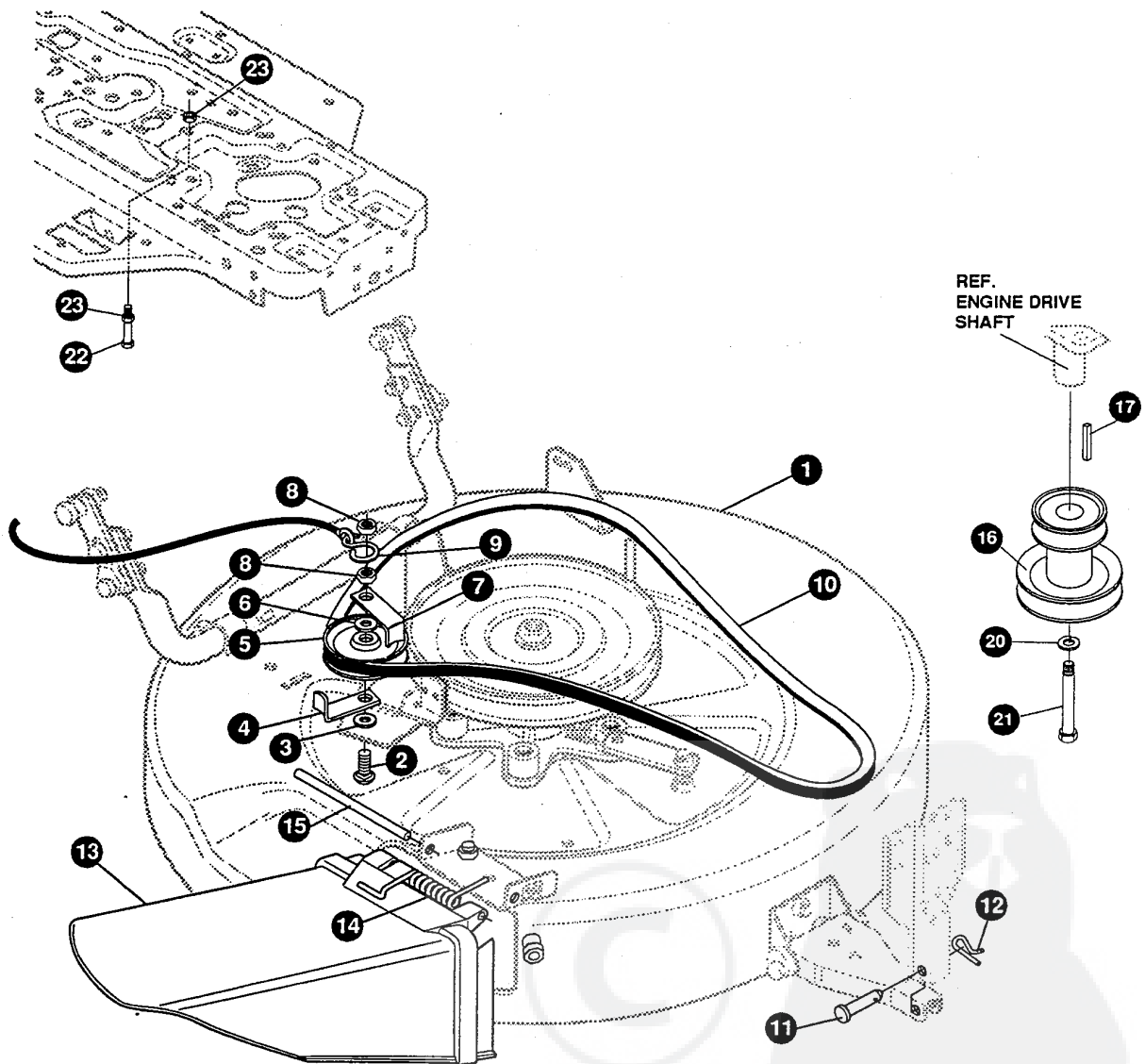

NOTE: ALWAYS USE ORIGINAL EQUIPMENT PARTS. Use of service/replacement parts other than original equipment parts may void your warranty.

ALL UNNUMBERED ITEMS ARE INTERCHANGEABLE WITH OPPOSITE SIDE

325642 C

KEY#	\$ PART#	DESCRIPTION	QTY
1	321982-853	DECK, MOWER 30"	1
2	301340	BOLT, 3/8-16X2.50 CARR	1
3	22265	WASHER, FLAT .515X1.38X.119PL	1
4	39659	RETAINER, BELT	1
5	45074	PULLEY, IDLER V4L 3.06X .72	1
6	25210	WASHER, FLAT .386X1.25X.09HT	1
7	39659	RETAINER, BELT	1
8	1499	NUT, 3/8-16 REGHXCTRLK	2
9	310734	HOOK, S, 10 GA. STEEL	1
10	321147	BELT, V 4L 54.0 - MOD SEC	1
11	47817	PIN, CLEVIS LONG	1
12	56180	PIN, HAIR .091 DIA X 1.62LG	1
13	315314	CHUTE DEFLECTOR 30" DECK	1
14	314975	SPRING, TORSION CHUTE DEFLECTOR	1
15	304424	ROD, PIVOT DECK .312DX7.25	1
16	328035	PULLEY, ENG 2.94OF/5.5D/3.00D	1
17	26655	KEY, SQUARE .250SQX2.50LG	1
20	120383	WASHER, REGSPTLK.459X.78X.12	1
21	182764	SCREW, 7/16-20X3.25 HHC	1
22	49930	SCREW, 3/8-16X7.50 HHC	1
23	1499	NUT, 3/8-16 REGHXCTRLK	2

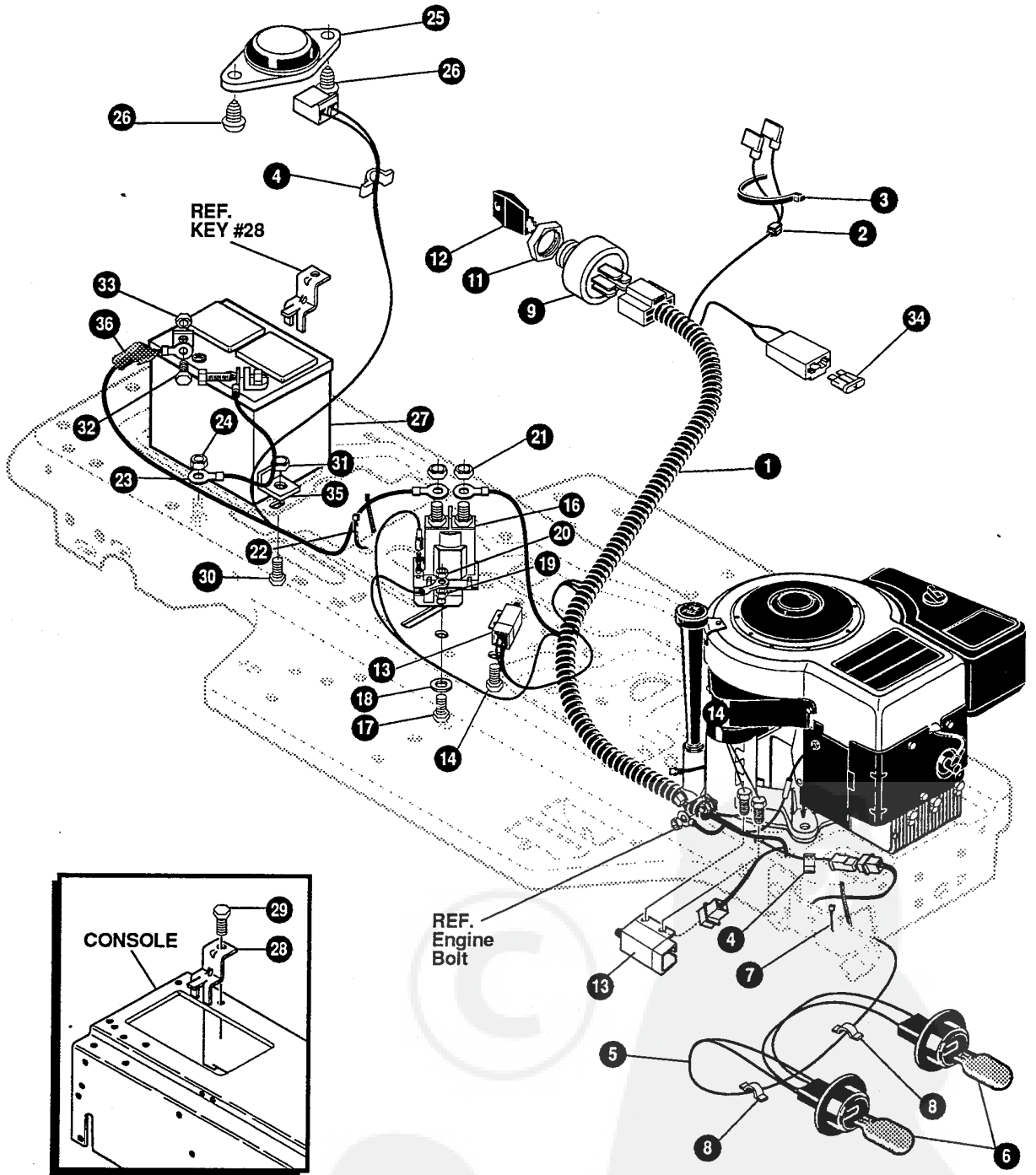

NOTE: ALWAYS USE ORIGINAL EQUIPMENT PARTS. Use of service/replacement parts other than original equipment parts may void your warranty.

ALL UNNUMBERED ITEMS ARE INTERCHANGEABLE WITH OPPOSITE SIDE

332431 A

KEY#	PART#	DESCRIPTION	QTY
1	331453	WIRE HARNESS SF 8-12B&S W/AMM	1
2	322298	SPLICER	1
3	57444	TIE, CABLE BLACK NYLON 5.62L	1
4	41482	PRESS CLIP, 1.380LG .255ID	2
5	303064	ASSY, LIGHT WIRE-1/4 TURN	1
6	52572	BULB, HEADLAMP	2
7	57444	TIE, CABLE BLACK NYLON 5.62L	1
8	41482	PRESS CLIP, 1.380LG .255ID	2
9	327354	SWITCH, IGNITION & LIGHTS DELTA	1
11	327352	NUT, 5/8-8ACME DELTA FOR BOOT	1
12	327350	KEY, IGNITION GENERIC DELTA	1
13	57476	SWITCH, SCR MNT DP NC NO BLK	2
14	300302	SCREW, #10 X .50 HHTAPPST BLK	4
16	53716	SOLENOID	1
17	187745	SCREW, 1/4-20X .75 HXSEMMA	2
18	1084	WASHER, FLAT .281X1.00X.063PL	1
19	1502	NUT, 1/4-20 REGHEXCTRLK	2
20	271172	NUT, 1/4-20 REGHEXKEPS	1
21	271187	NUT, 5/16-24 HKEPS	2
22	57444	TIE, CABLE BLACK NYLON 5.62L	1
23	55511	WIRE, GROUND, 12.5"	1
24	271184	NUT, 5/16-18 HEXKEPS	1
25	57547	SWITCH, SEAT	1
26	160505	SCREW, 1/4-20X .38PHPNHMA	2
27	302257	BATTERY, 12V	1
28	329175	LF BATTERY BRACKET	1
29	995346	SCREW, 1/4-20X .50 WAHHTAP	1
30	187745	SCREW, 1/4-20X .75 HXSEMMA	1
31	1502	NUT, 1/4-20 REGHEXCTRLK	1
32	120854	SCREW, 1/4-20X .63 HHC	2
33	271172	NUT, 1/4-20 REGHEXKEPS	2
34	302031	FUSE SPADE TYPE 32V 15A	1
35	9149	LF BRKT, CABLE RETAIN	1
36	308201	INSULATOR, BATTERY BOOT EURO	1

SCHEMATIC DRAWING

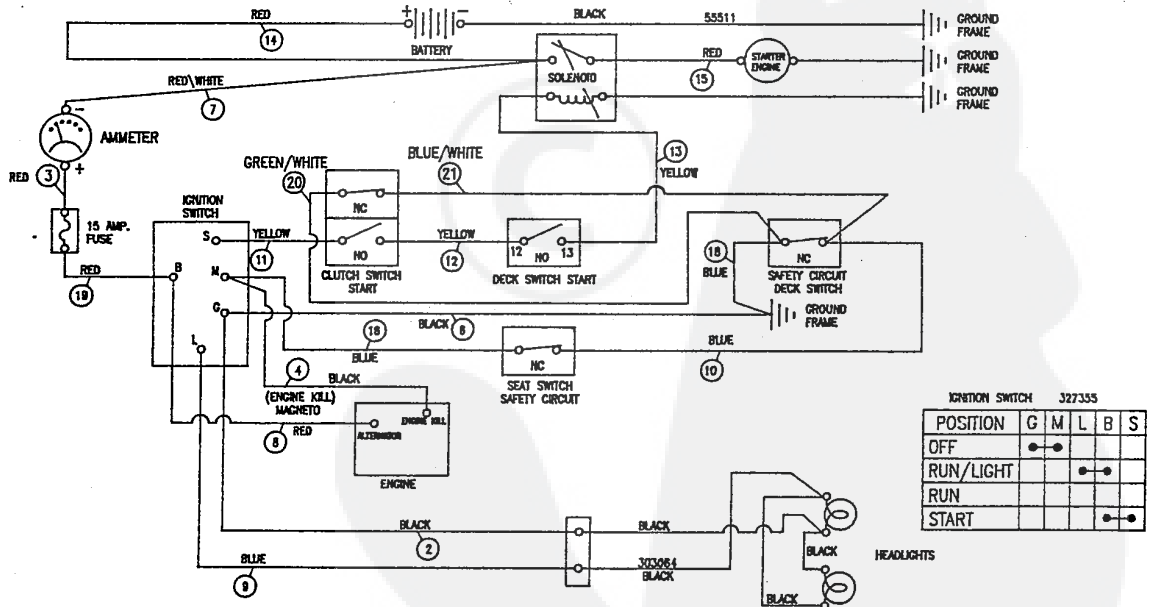

331453

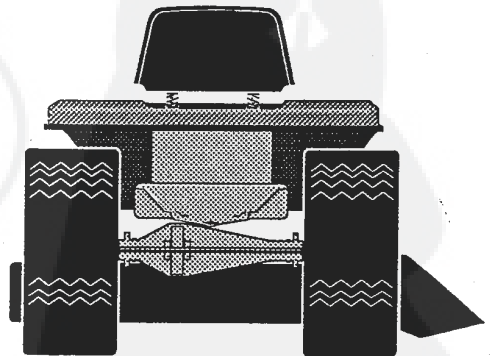
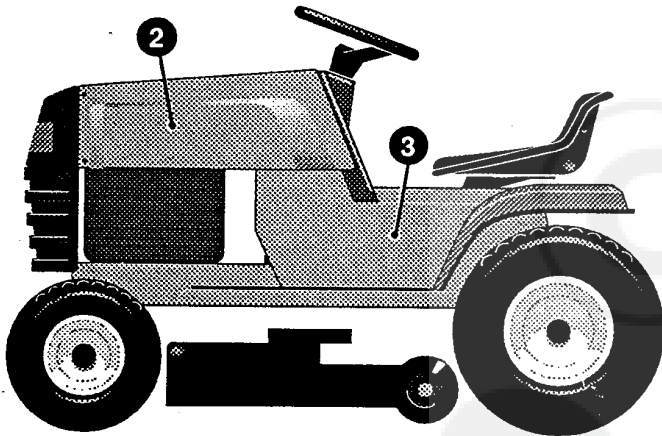
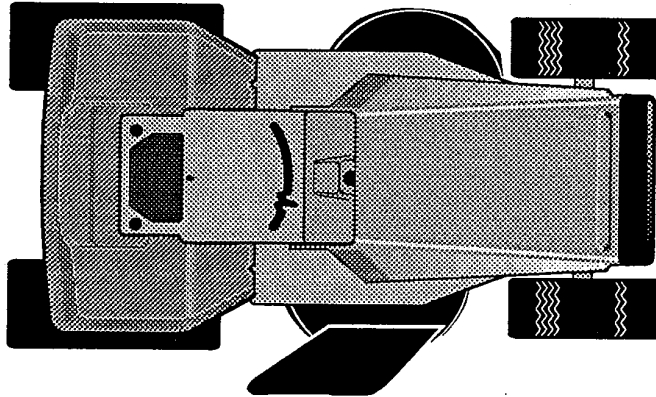
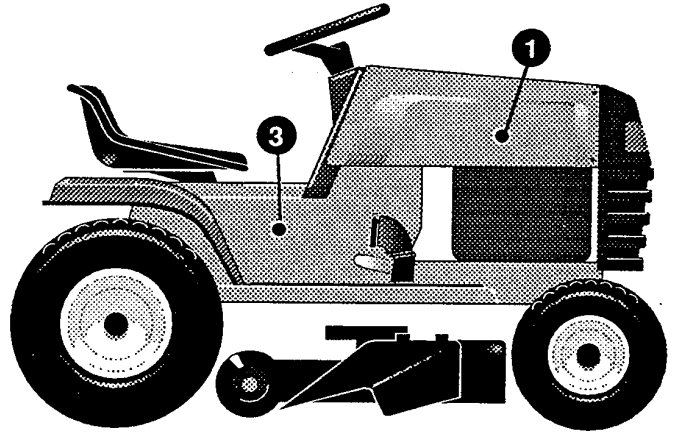
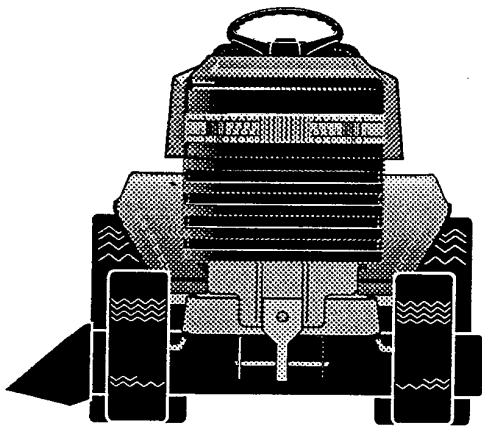

KEY#	PART#	DESCRIPTION	QTY
1	402358	DECAL, HOOD-RH GARDENSTAR 1030	1
2	402357	DECAL, HOOD-LH GARDENSTAR 1030	1
3	301536	NAME PLATE, 10/30 WHITE	2

332606 A

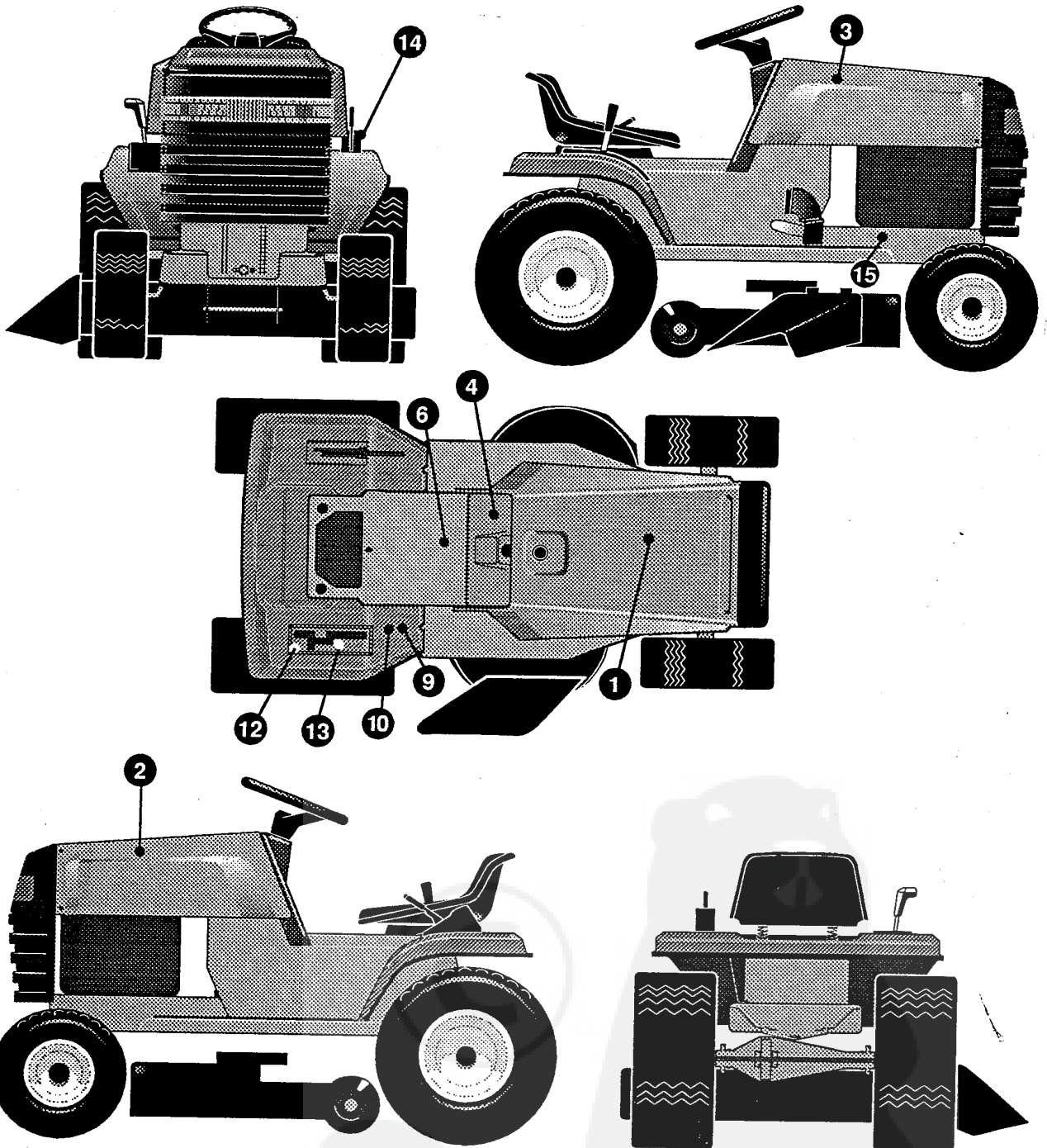

KEY#	PART#	DESCRIPTION	QTY
1	55832	PAD, FOAM TOP HOOD H-4	1
2	55833	PAD, FOAM HOOD H-4 SIDE LH	1
3	55834	PAD, FOAM HOOD H-4 SIDE RH	1
4	320686	DECAL DASH, DYNAMARK EXP	1
6	69524	DECAL, INSTRUCT CONSOLE TOP GER	1
9	305770	DECAL, CAUTION TRIANGLE EUROPE	1
10	68902	DECAL, WARNING, FRENCH/GERMAN	1
12	311394	DECAL SHIFT REV/NEUTRAL	1
13	331013	DECAL SHIFTER POSITION	1
14	402214	DECAL, HEIGHT ADJUST	1
15	68903	DECAL, BRAKE/CLUTCH ISO	1

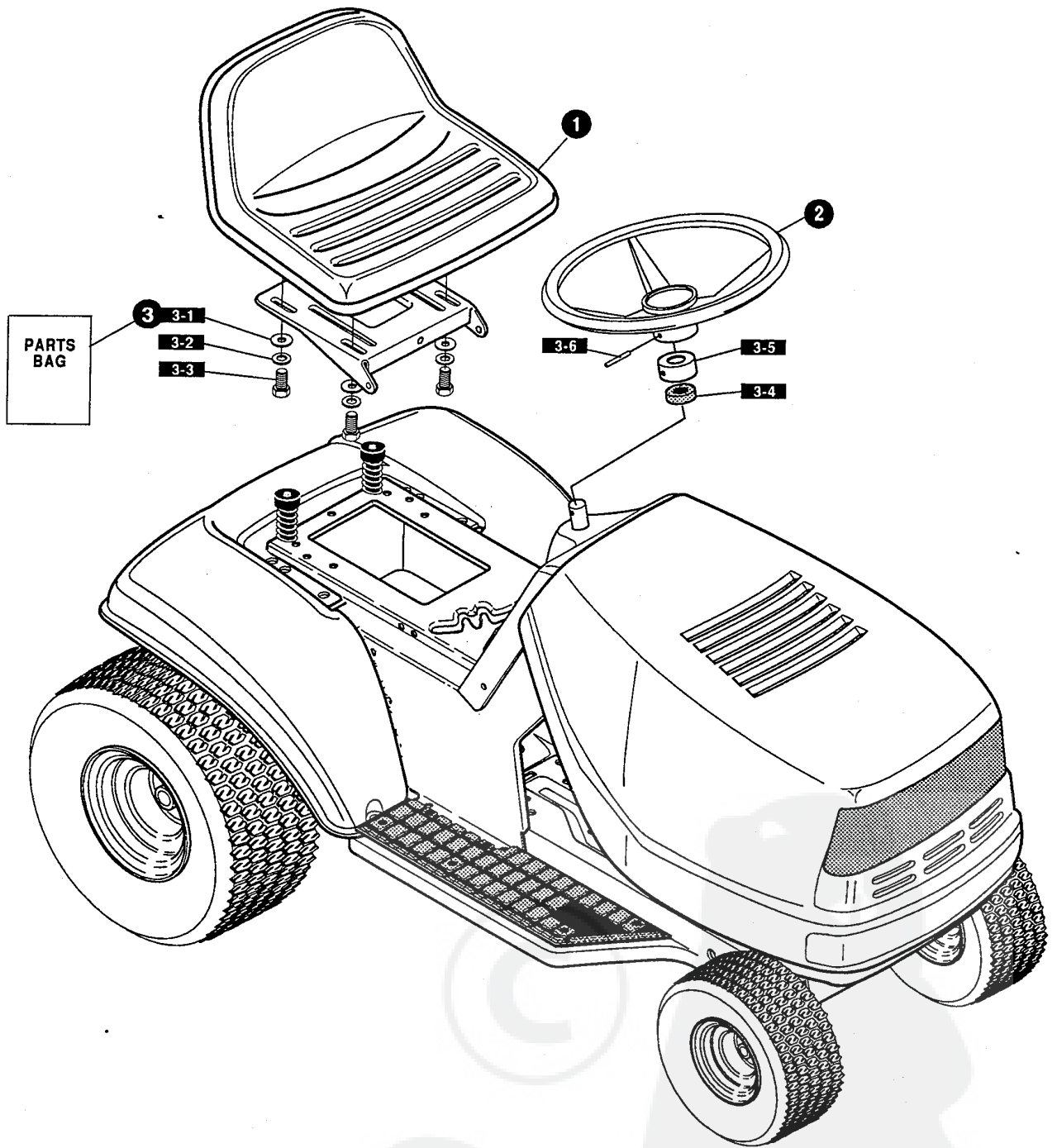

KEY#	PART#	DESCRIPTION	QTY
1	304314	SEAT,MICHIGAN GEN, W/SW HOLE	1
2	330510	STEERING WHEEL	1
3	331424	SF PARTS BAG,ASSY SEAT/STEER	1
1	120393	WASHER, FLAT .344X.69X.065	4
2	120638	WASHER, HVSPTLK .328X.60X.09	4
3	122007	SCREW, 5/16-18X .75 HHC	4
4	331322	COVER, STEERING SHAFT	1
5	301413	SPACER, STEERING SHAFT	1
6	456378	PIN, SPRING.250D/AX2.00LG HVPL	1

327405 D

TREAD PATTERNS

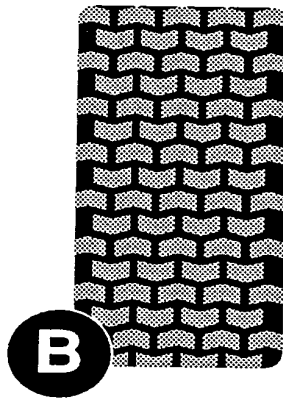
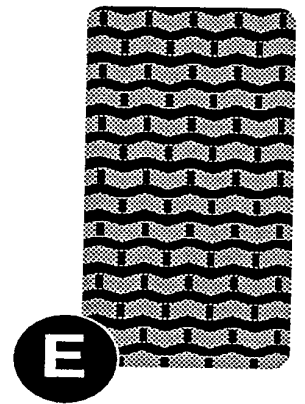
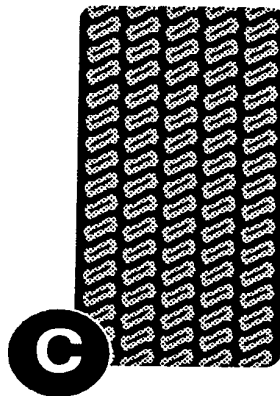
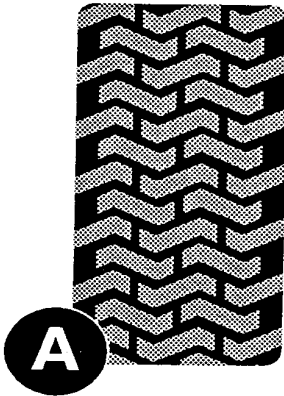

TIRE SIZE	"A"	"B"	"C"	"D"	"E"
11 X 4.00 - 5	42295	319679			
13 X 5.00 - 6	41060	319680			
15 X 6.00 - 6	39830	316702	301140	313952	
16 X 4.80 - 8		305035			
16 X 6.50 - 8	41081	319682		314539	
18 X 6.50 - 8		42091			
18 X 8.50 - 8	319683	317400			
18 X 9.50 - 8	41106	316701		313950	
20 X 8.00 - 8	319685	319684	57164	314584	331606
20 X 10.00 - 8	58276	319686		313654	
20 X 10.00 - 10	55893	319687			
23 X 9.50 - 12	53655	319690	319689	314370	

Contact the dealer where your tractor was purchased for the available accessories. If are unable to contact the dealer, write to the address on the front cover of this manua

30" Standard Lawn Rider

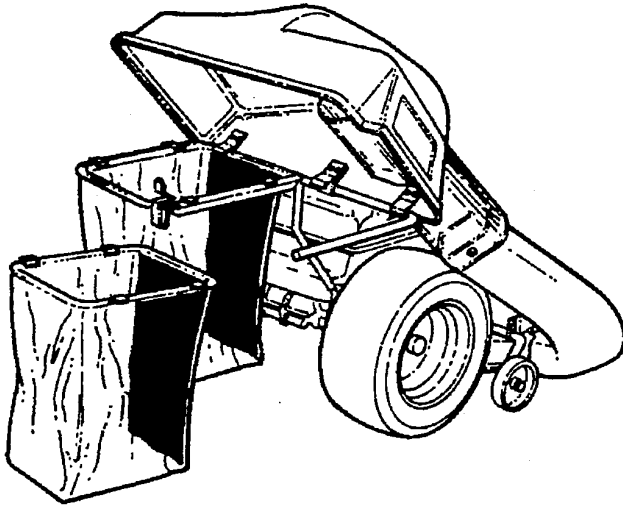

Model #5708-17
Grass Collector (30" decks)

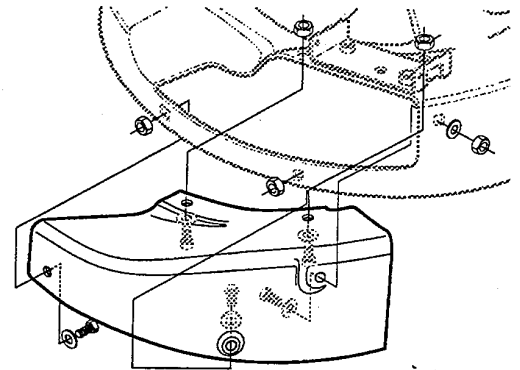

5714-00 Mulching Kit (30" Deck)

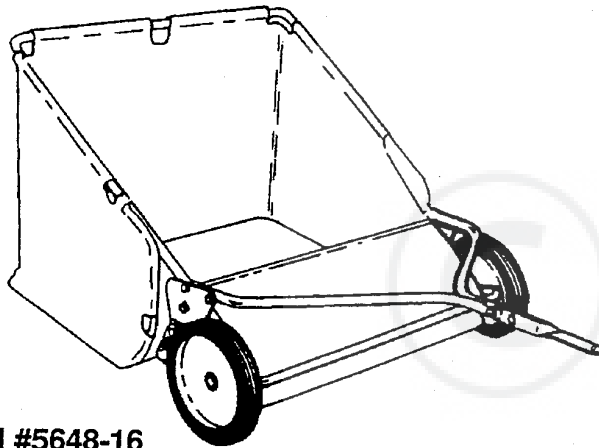

Model #5648-16
Tow Behind Lawn Sweeper for Grass and Leaves

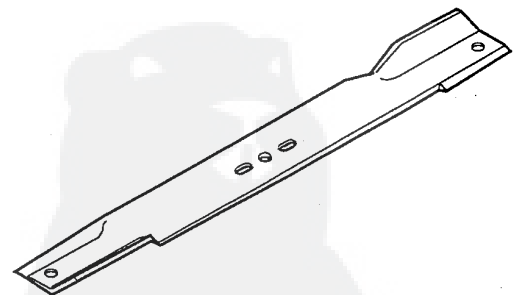

314275 -30" Standard Lift Blade

OTHER ACCESSORIES

Model	Description
5709-02	Front Weight Box - holds 35 lbs.
322397	30" Mulching blade