

# DYNAMARK®

## PARTS MANUAL

### Lawn Tractors



**Model E3560-820**

# SAFETY RULES

**THESE INSTRUCTIONS ARE FOR YOUR PROTECTION. PLEASE READ THEM CAREFULLY.**

## **IMPORTANT**

**THIS CUTTING MACHINE IS CAPABLE OF AMPUTATING HANDS AND FEET AND THROWING OBJECTS. FAILURE TO OBSERVE THE FOLLOWING SAFETY INSTRUCTIONS COULD RESULT IN SERIOUS INJURY OR DEATH.**

### **I. GENERAL OPERATION:**

- Know controls and how to stop quickly.
- Read, understand, and follow all instructions in the manual and on the machine before starting.
- Only allow responsible adults, who are familiar with instructions, to operate the machine.
- Wear safety glasses or eye shields when assembling or operating the machine.
- Do not operate machine when barefooted. Always wear substantial footwear, preferably steel-toed shoes.
- Do not wear loose fitting clothing that could get caught in moving parts.
- Clear the area of objects such as rocks, toys, wire, etc., which could be picked up and thrown by the blade(s).
- Be sure the area is clear of other people before mowing. Stop machine if anyone enters the area.
- Never carry passengers.
- Do not mow in reverse unless absolutely necessary. Always look down and behind before and while backing.
- Be aware of the mower discharge direction and do not point it at anyone. Do not operate the mower without either the entire grass catcher or the guard in place.
- Slow down before turning.
- Never leave a running machine unattended. Always turn off blades, set parking brake, stop engine, and remove keys before dismounting.
- Turn off blade(s) when not mowing.
- Stop engine before removing grass catcher or unclogging chute.
- Mow only in daylight or good artificial light.
- Do not operate the machine while under the influence of alcohol or drugs.
- Watch for traffic when operating near or crossing roadways.
- Use care when mowing around a fixed object to prevent the blade(s) from striking it. Never deliberately run over any foreign object.
- Use extra care when loading or unloading the machine into a trailer or truck.
- Use care when pulling loads or using heavy equipment.
  - a. Use only approved drawbar hitch points.
  - b. Limit loads to those that you can safely control.
  - c. Do not turn sharply. Use care when backing.
  - d. Use counterweight(s), wheel weight or tire chains when suggested in attachment(s) instructions.

### **II. SLOPE OPERATION:**

Slopes are a major factor related to loss-of-control and tip-over accidents, which can result in severe injury or death. *All slopes require extra caution.* If you cannot back up the slope or if you feel uneasy on it, do not mow it.

#### **DO**

- Mow up and down slopes, not across.
- Remove obstacles such as rocks, tree limbs, etc.
- Watch for holes, ruts, or bumps. Uneven terrain could overturn the machine. *Tall grass can hide obstacles.*
- Use slow speed. Choose a low gear so that you will not have to stop or shift while on the slope.
- Follow the manufacturer's recommendations for wheel weights or counterweights to improve stability.
- Use extra care with grass catchers or other attachments. These can change the stability of the machine.
- Keep all movement on the slopes *slow* and *gradual*. Do not make sudden changes in speed or direction.
- Avoid starting or stopping on a slope. If tires lose traction, turn off the blade(s) and proceed slowly *straight* down the slope.

#### **DO NOT**

- Do not turn on slopes unless necessary, and then slowly and gradually downhill, if possible.
- Do not mow near drop-offs, ditches or embankments. The

mower could suddenly turn over if a wheel is over the edge of a cliff or ditch, or if an edge caves in.

- Do not mow on wet grass. Reduced traction could cause sliding.
- Do not try to stabilize the machine by putting your foot on the ground.
- Do not use grass catcher on steep slopes.

### **III. CHILDREN:**

Tragic accidents can occur if the operator is not alert to the presence of children. Children are often attracted to the machine and the mowing activity. *Never* assume that children will remain where you last saw them.

- Keep children out of the mowing area and under the watchful care of another responsible adult.
- Be alert and turn machine off if children enter the area.
- Before and when backing, look behind and *down* for small children.
- Never carry children. They may fall off and be seriously injured or interfere with safe machine operation.
- Never allow children to operate the machine.
- Use extra care when approaching blind corners, shrubs, trees, or other objects that may obscure vision.

### **IV. SERVICE:**

- Use extra care in handling gasoline and other fuels. They are flammable and vapors are explosive.
  - a. Use only an approved container.
  - b. Never remove gas cap or add fuel with the engine running. Allow engine to cool before refueling. Do not smoke.
  - c. Never refuel the machine indoors.
  - d. Never store the machine or fuel container inside where there is an open flame, such as in a water heater.
- Check fuel supply before each use allowing space for expansion as the heat of the engine and/or sun can cause gasoline to expand and overflow the tank.
- Use extra care when handling battery acid. Acid contact with skin may cause severe burns. Eye contact may cause blindness.
- Use extra care when servicing the battery. Explosive gas is produced in the battery. Do not service the battery while smoking or near an open spark or flame. This may cause the battery to explode causing serious injury.
- Never run a machine inside a closed area. Exhaust fumes contain CARBON MONOXIDE, an ODORLESS and DEADLY GAS.
- Keep nuts and bolts, especially blade attachment bolts, tight and keep equipment in good condition.
- Never tamper with safety devices. Check their operation regularly.
- Do not change the engine governor settings or overspeed engine.
- Reduce fire hazards. Keep machine free of grass, leaves, or other debris build-up. Clean up oil or fuel spillage. Allow machine to cool before storing.
- Stop and inspect the equipment if you strike an object. Repair, if necessary, before restarting.
- Never make adjustments or repairs with the engine running.
- Grass catcher components are subject to wear, damage, and deterioration, which could expose moving parts or allow objects to be thrown. Frequently check components and replace with manufacturer's recommended parts, when necessary.
- Mower blade(s) are sharp and can cut. Wrap the blade(s) or wear gloves, and use extra caution when servicing them.
- Check brake operation frequently. Adjust and service as required.



**LOOK FOR THIS SYMBOL TO POINT OUT IMPORTANT SAFETY PRECAUTIONS. IT MEANS--ATTENTION!!! BECOME ALERT!!! YOUR SAFETY IS INVOLVED.**

Record the following information about your unit so that you will be able to provide it in case of loss or theft.

MODEL NUMBER:  -  (Enter complete 8 digit number from model plate on unit)

PURCHASE DATE: \_\_\_ / \_\_\_ / \_\_\_ CODE NO.: \_\_\_\_\_ SERIAL NO.: \_\_\_\_\_

DEALER'S NAME AND ADDRESS: \_\_\_\_\_

CITY: \_\_\_\_\_ STATE: \_\_\_\_\_ TELEPHONE: \_\_\_\_\_

### TOOLS REQUIRED FOR ASSEMBLY

- 2 - 7/16 inch Wrenches (or adjustable wrench)
- 1 - 1/2 inch Wrench (or adjustable wrench)
- 1 - Small Phillips Screwdriver with a 1/4 inch shank
- 1 - Hammer

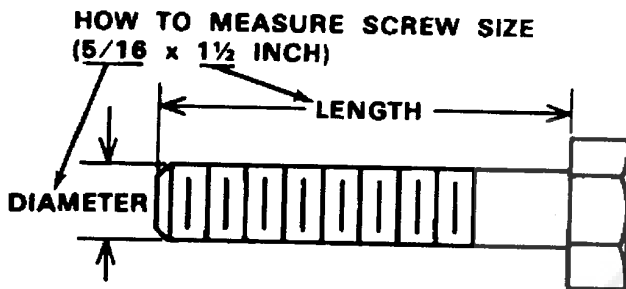

## DANGER



This lawn tractor can be dangerous if carelessly used.

Read your Operator's Manual thoroughly before operating your lawn tractor.

Always wear safety glasses or eye shields while assembling or operating your lawn tractor.

DO NOT carry passengers at any time.

Keep your hands, feet, hair and loose clothing away from the discharge area, the underside of the mower deck or any moving parts while the engine is running.

DO NOT allow children or young teenagers to operate or be near your lawn tractor while it is operating.

ALWAYS GIVE THE FOLLOWING INFORMATION WHEN ORDERING REPAIR PARTS:  
1. The PART NUMBER; 2. The PART NAME; 3. QUANTITY DESIRED; 4. The MODEL NUMBER (As shown on Model Plate).

SEND PART ORDERS AS PER INSTRUCTIONS ON THE FRONT PAGE.

DO NOT USE KEY NUMBERS WHEN ORDERING REPAIR PARTS, ALWAYS USE PART NUMBERS.

All replacement parts will be supplied in current production colors or in a neutral color.

A handling fee is applicable to small parts orders.

YOUR UNIT IS RIGHT HAND (RH) OR LEFT HAND (LH) AS YOU STAND BEHIND IT.

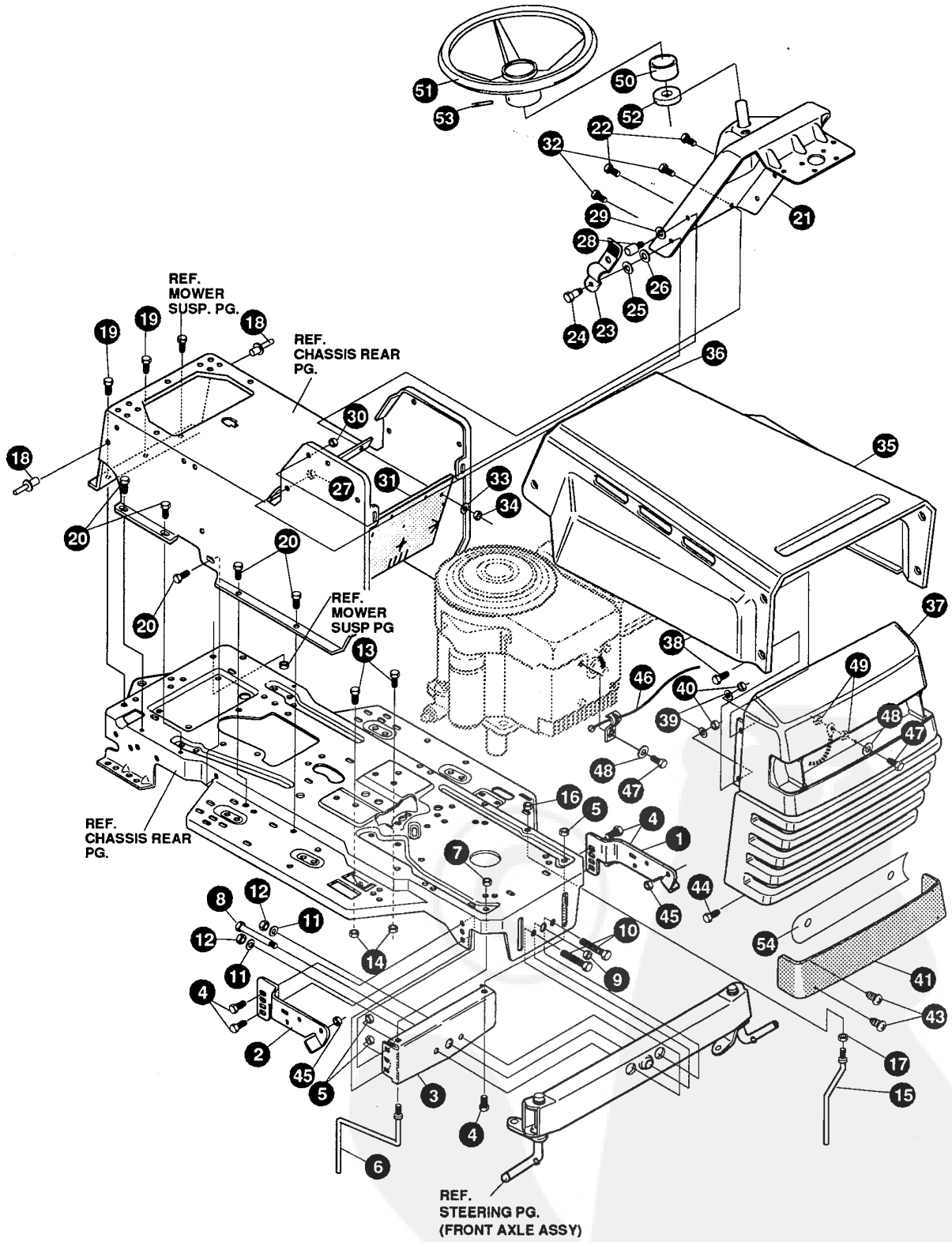

**NOTE: ALWAYS USE ORIGINAL EQUIPMENT PARTS.** Use of service/replacement parts other than original equipment parts may void your warranty.

**ALL UNNUMBERED ITEMS ARE INTERCHANGEABLE WITH OPPOSITE SIDE**

325873 D

**E3560-820****FRONT CHASSIS & HOOD ASSEMBLY**

KEY#	PART#	DESCRIPTION	QTY
1	313001-853	BRACKET, GRILLE SUPPORT LH .....	1
2	313002-853	BRACKET, GRILLE SUPPORT RH .....	1
3	313541-853	BRACKET, FRONT AXLE .....	1
4	56030	SCREW, 5/16-18 X .75 WDFLLK .....	5
5	55273	NUT, 5/16-18 HXWDFLLK .....	5
6	300440	GUIDE, BELT, RIDER .....	1
7	1498	NUT, 5/16-18 REGHEXCTRLK .....	1
8	308207	BOLT, .625 X 2.18 HSH 1/2-13 .....	1
9	309008	NUT, 1/2-13 HEXJAM CTRLK .....	1
10	180138	SCREW, 3/8-16 X 3.00 HHC .....	2
11	2483	WASHER, .39 ID X 1.25 D X .07 BELLVIL .....	2
12	1499	NUT, 3/8-16 REGHXCTRLK .....	2
13	180079	SCREW, 5/16-18 X 1.00 HHC .....	2
14	1498	NUT, 5/16-18 REGHEXCTRLK .....	2
15	300635	GUIDE, BELT SHORT 15" WHEEL .....	1
16	124824	NUT, 5/16-18 HEXJAM .....	1
17	271190	NUT, 3/8-16 HEXKEPS .....	1
18	46763	RIVET, POP .187 DIA X .450 LG ST .....	3
19	35497	SCREW, 5/16-18 X .50 WAHTAP .....	2
20	995346	SCREW, 1/4-20 X .50 WAHTAP .....	10
21	309447-860	DASH STEEL, LF SUSPENDED .....	1
22	995346	SCREW, 1/4-20 X .50 WAHTAP .....	2
23	57159	LATCH, .94 WD X .047 ASSEMBLY HOOD .....	2
24	8482	BOLT, .375 X .156 HSH 5/16-18 .....	2
25	120394	WASHER, FLAT .406 X .81 X .065 .....	2
26	120393	WASHER, FLAT .344 X .69 X .065 .....	2
27	1498	NUT, 5/16-18 REGHEXCTRLK .....	2
28	53446	PIN, 5/16-18 HOOD LATCH .....	2
29	138538	WASHER, REGINTLK .320 X .61 X .03 .....	2
30	45174	NUT, 5/16-18 HEXWDFLLK WHIZ .....	2
31	312306	BAFFLE, CONSOLE SOUND EXPORT LF .....	1
32	300314	SCREW, 1/4-20 X .88 WAHTAP .....	2
33	120392	WASHER, FLAT .281 X .63 X .065 .....	2
34	1502	NUT, 1/4-20 REGHEXCTRLK .....	2
35	314537-860	HOOD, LF H-20 .....	1
36	56304	EDGING (78"-47453) WIDE BLK .....	27.5"
37	325401	GRILLE, G17 .....	1
38	274672	SCREW, 1/4-20 X .63 WAHHC .....	4
39	120393	WASHER, FLAT .344 X .69 X .065 .....	4
40	1502	NUT, 1/4-20 REGHEXCTRLK .....	4
41	302333	LENS, SMOKED W/TAB NO LOGO .....	1
43	57796	SCREW, #6 X .50 PLASTITE/HI-LO .....	4
44	36149	BOLT, .375 X .500 HSH 5/16-18 .....	2
45	1498	NUT, 5/16-18 REGHEXCTRLK .....	2
46	311094	LANYARD, HOOD 11.75LG H15 VANG .....	1
47	48900	SCREW, 1/4-20 X 1.00 WAHHC .....	1
48	120392	WASHER, FLAT .281 X .63 X .065 .....	1
49	1502	NUT, 1/4-20 REGHEXCTRLK .....	2
50	311465	COVER, STEERING SHAFT .....	1
51	330510	STEERING WHEEL .....	1
52	301413	SPACER, STEERING SHAFT .....	1
53	456378	PIN, SPRING .250 DIA X 2.00 LG HVPL .....	1
54	314948	FOIL, LENS REFLECTOR .....	1
55	333810	PARTS MANUAL .....	1
56	332212	OPERATOR'S MANUAL (ENGLISH) .....	1
57	332213	OPERATOR'S MANUAL (FRENCH) .....	1
58	332214	OPERATOR'S MANUAL (GERMAN) .....	1

# E3560-820

# REPAIR PARTS

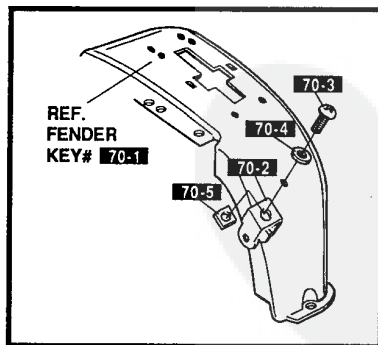
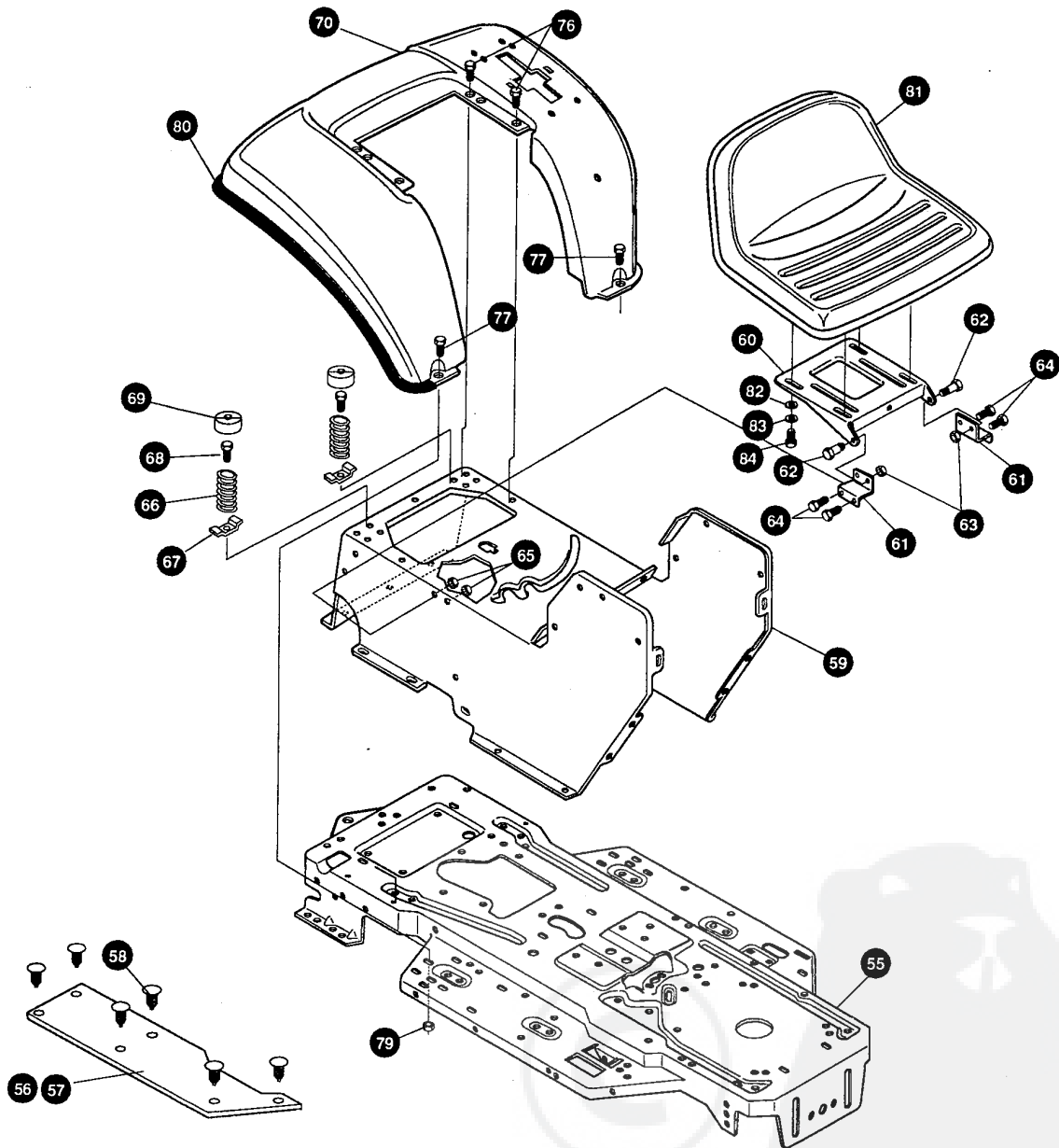

**NOTE: ALWAYS USE ORIGINAL EQUIPMENT PARTS.** Use of service/replacement parts other than original equipment parts may void your warranty.

**ALL UNNUMBERED ITEMS ARE INTERCHANGEABLE WITH OPPOSITE SIDE**

325899 B

**E3560-820****REAR CHASSIS & HOOD ASSEMBLY**

KEY#	PART#	DESCRIPTION	QTY
55	326579-860	FRAME, LF DRILLED P920/F4360 .....	1
56	310005	FOOT PAD, LH 22.12LG, F-5 .....	1
57	310006	FOOT PAD, RH 22.12LG, F-5 .....	1
58	309235	FASTENER, RATCHET BLACK .....	12
59	309657-860	CONSOLE, LF TOPSHIFT .....	1
60	58367-853	PLATE, SEAT F5 SF, LF .....	1
61	310660-853	BRACKET, F-5 SEAT SUPPORT .....	2
62	20507	BOLT, .437 X .156 HSH 5/16-18 .....	2
63	1498	NUT, 5/16-18 REGHEXCTRLK .....	2
64	48901	SCREW, 5/16-18 X .63WAHHC .....	4
65	1498	NUT, 5/16-18 REGHEXCTRLK .....	4
66	57153	SPRING, SEAT 2.63 LG, 1.49 OD BLK .....	2
67	1341	CLAMP, SPRING 1.17"ID .....	2
68	44811	SCREW, 1/4-20 X .75 WAHTAP .....	2
69	56907	COVER, SEAT SPRING 1.5 ID X 1.0 LG .....	2
70	^	ASSEMBLY, FENDER F5 LF SUSPENDED .....	1
70-1	332187-860	FENDER, F5,SUS, LF, STD, SHIFT .....	1
70-2	9239	CLEVIS .....	1
70-3	439455	SCREW, 5/16-18 X .56 PHPNMA BKPH .....	1
70-4	301551	WASHER, .344 ID X 1.50 D X .09 CU .....	1
70-5	120373	NUT, 5/16-18 SQ .....	1
76	995346	SCREW, 1/4-20 X .50 WAHTAP .....	4
77	126358	BOLT, 5/16-18 X 1.00 CARRLN .....	2
79	55273	NUT, 5/16-18 HXWDFLLK .....	2
80	55023	TRIM, 77.5" BLACK NARROW .....	75.0"
81	57455	SEAT, MICHIGAN, W/SW HOLE .....	1
82	120393	WASHER, FLAT .344 X .69 X .065 .....	4
83	120638	WASHER, HVSPTLK .328 X .60 X .09 .....	4
84	180077	SCREW, 5/16-18 X .75 HHC .....	4

^ ORDER INDIVIDUAL PARTS

# E3560-820

# REPAIR PARTS

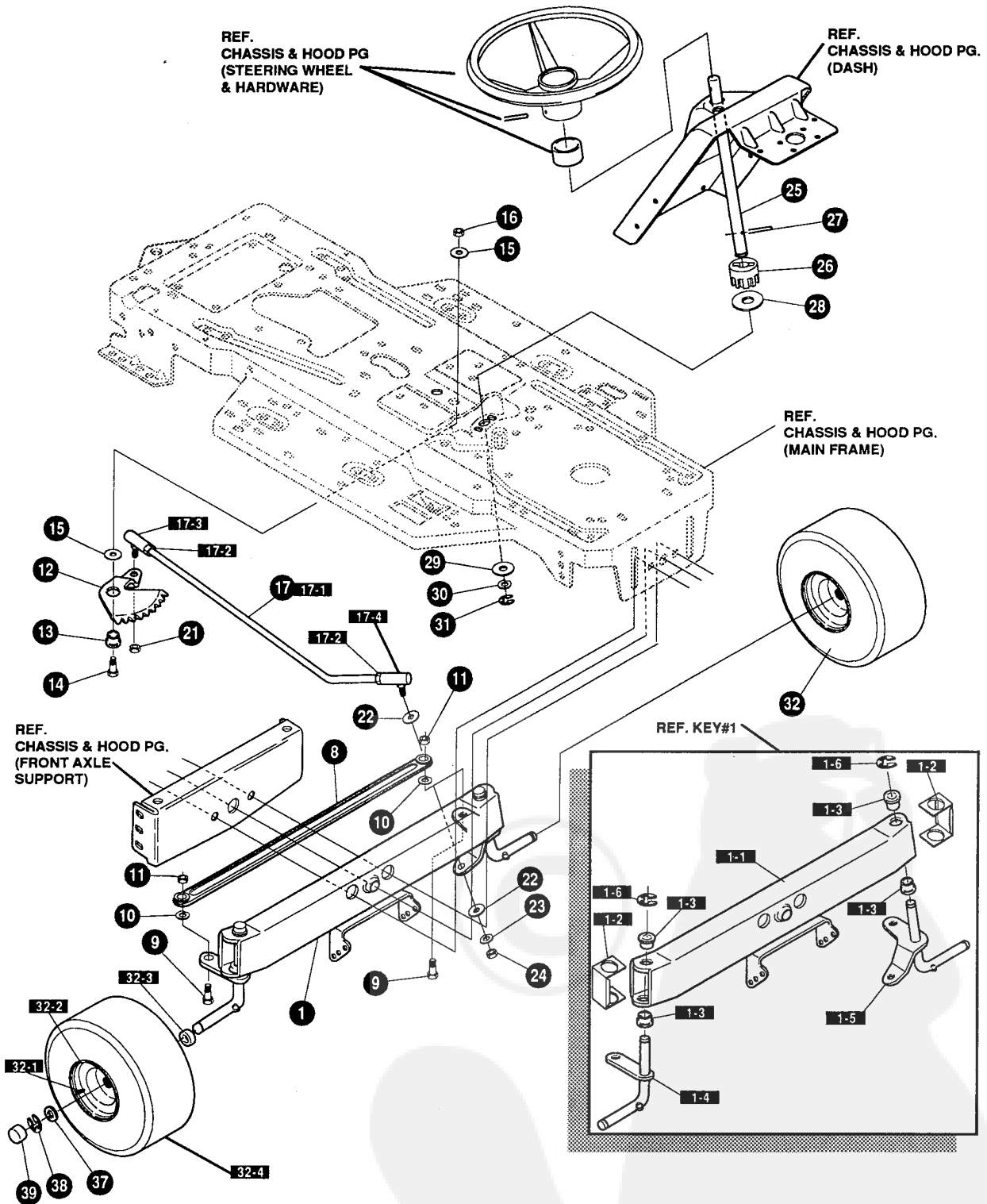

**NOTE:** ALWAYS USE ORIGINAL EQUIPMENT PARTS. Use of service/replacement parts other than original equipment parts may void your warranty.

**ALL UNNUMBERED ITEMS ARE INTERCHANGEABLE WITH OPPOSITE SIDE**

315136 I



**E3560-820****STEERING ASSEMBLY**

KEY#	PART#	DESCRIPTION	QTY
1	^	ASSEMBLY, AXLE FRONT 4/WS SUSPENSION .....	1
1-1	310170-853	AXLE, FRONT .....	1
1-2	53373-853	AXLE COVER .....	2
1-3	52407	SPINDLE BEARING .....	4
1-4	302926	ASSEMBLY, SPINDLE RH .....	1
1-5	315886	ASSEMBLY, SPINDLE LH .....	1
1-6	36625	RING, RETEX .57 X .05 TRU 5133-75 .....	2
8	304590	TIE ROD ASSEMBLY, 19.81 LG W-SECTION .....	1
9	180128	SCREW, 3/8-16 X 1.75 HHC .....	2
10	120382	WASHER, REGSPTLK .393 X .68 X .10 .....	2
11	120377	NUT, 3/8-16 REGHX .....	2
12	58289	SECTOR, STEERING LF .....	1
13	52406	BEARING, FLANGE ECC .510 ID X .998 OD X .56 .....	1
14	180177	SCREW, 1/2-13 X 1.50 HHC .....	1
15	22265	WASHER, FLAT .515 X 1.38 X .119 .....	2
16	1500	NUT, 1/2-13 REGHCTRLK .....	1
17	311100	KIT, 300146 DRAGLINK .....	1
17-1	58291	STEERING LINK .....	1
17-2	124925	NUT, 3/8-24 REGHEXJAM .....	2
17-3	57158	BALL JOINT, 3/8 THD SHORT STUD .....	1
17-4	21275	BALL JOINT, 3/8 THD LONG STUD .....	1
21	46692	NUT, 3/8-24 WDFLHLK WHIZ .....	1
22	996416	WASHER, FLAT .391 X 1.00 X .125 .....	2
23	120382	WASHER, REGSPTLK .393 X .68 X .10 .....	1
24	120369	NUT, 3/8-24 REGHEX .....	1
25	58243	SHAFT, STEERING LF, 2WS .....	1
26	58244	PINION, STEERING LF .....	1
27	58274	PIN, DOWEL .2500 OD + 1.75 LG .....	1
28	301410	BEARING, FLANGE .752 ID X 1.061 OD X .24 .....	1
29	301398	WASHER, FORMED 1.135 X 1.53 X .12 .....	1
30	21682	WASHER, FLAT .765 X 1.25 X .042 .....	1
31	36625	RING, RETEX .57 X .05 TRU 5133-75 .....	1
32	302828	TIRE & RIM, PU 15 X 6.0 X 6 .....	2
32-1	24167	VALVE STEM	
32-2	39829	RIM, WHEEL	
32-3	314416	BEARING, FLANGE	
32-4	TIRE	REFER TO TIRE TREAD PAGE	
37	642	WASHER, FLAT .755 X 1.31 X .075 .....	4
38	36625	RING, RETEX .57 X .05 TRU 5133-75 .....	2
39	40394	HUB CAP, 1.500 ID X 7/8 LG .....	2

^ ORDER INDIVIDUAL PARTS

# E3560-820

# REPAIR PARTS

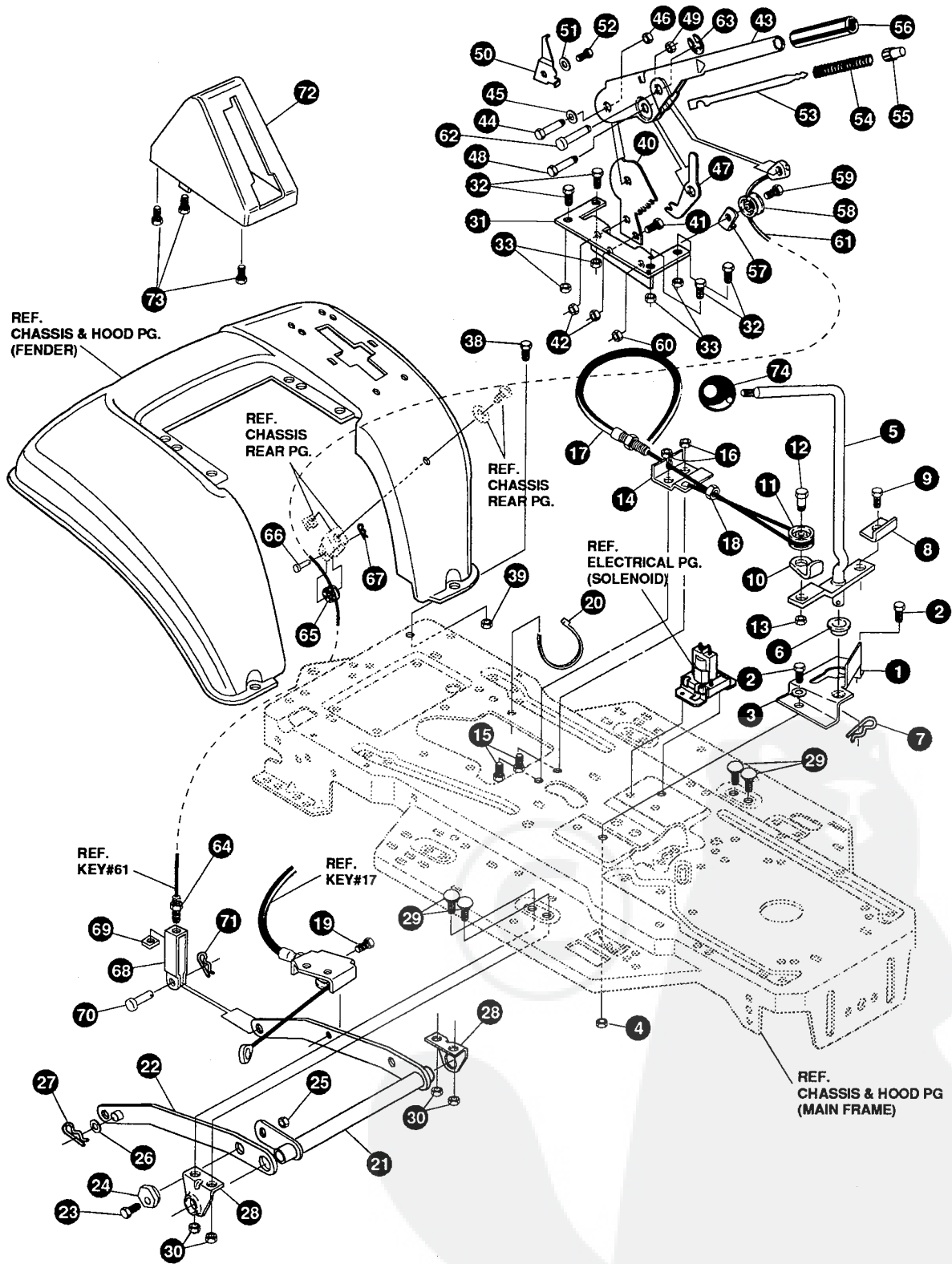

**NOTE:** ALWAYS USE ORIGINAL EQUIPMENT PARTS. Use of service/replacement parts other than original equipment parts may void your warranty.

**ALL UNNUMBERED ITEMS ARE INTERCHANGEABLE WITH OPPOSITE SIDE**

325815 D

**E3560-820****MOWER SUSPENSION ASSEMBLY**

KEY#	PART#	DESCRIPTION	QTY
1	320075-853	BRACKET, CLUTCH ENGAGE LEVER .....	1
2	180079	SCREW, 5/16-18 X 1.00 HHC .....	2
3	120393	WASHER, FLAT .344 X .69 X .065 .....	2
4	1498	NUT, 5/16-18 REGHEXCTRLK .....	2
5	304791	ASSEMBLY, CLUTCH LEVER .....	1
6	50148	BEARING, FLANGE .503 ID X .63 OD X .50 .....	1
7	8260	PIN, HAIR .091 DIA X 1.66 LG .....	1
8	318341	BRACKET, SWITCH ENGAGE .....	1
9	35498	SCREW, 5/16-18 X .75 WAHTAP .....	1
10	1288	BRACKET, CABLE RETAIN .....	1
11	48306	PULLEY, POWDER METAL .....	1
12	58336	BOLT, .375 X .375 HSSH 1/4-20 .....	1
13	1502	NUT, 1/4-20 REGHEXCTRLK .....	1
14	300698-853	BRACKET FRAME CABLE .....	1
15	180020	SCREW, 1/4-20 X .75 HHC .....	2
16	1502	NUT, 1/4-20 REGHEXCTRLK .....	2
17	301503	ASSEMBLY, CABLE, BLADE ENGAGE .....	1
18	120613	NUT, 1/4-28 HJAM .....	1
19	35498	SCREW, 5/16-18 X .75 WAHTAP .....	1
20	57444	TIE, CABLE BLACK NYLON 5.62 L .....	1
21	300158-853	LIFT ASSEMBLY, LH .....	1
22	300169-853	LIFT ASSEMBLY, RH .....	1
23	180079	SCREW, 5/16-18 X 1.00 HHC .....	1
24	58247	NUT, ADJUST .....	1
25	1498	NUT, 5/16-18 REGHEXCTRLK .....	1
26	417098	WASHER, FLAT .531 X 1.06 X .063 .....	2
27	8260	PIN, HAIR .091 DIA X 1.66 LG .....	2
28	58248-853	BRACKET, REAR HANG SUSPENSION .....	2
29	57072	BOLT, 5/16-18 X .63 CARRLN .....	4
30	1498	NUT, 5/16-18 REGHEXCTRLK .....	4
31	313926	BRACKET, HEIGHT/ADJUST SUPPORT .....	1
32	180077	SCREW, 5/16-18 X .75 HHC .....	4
33	1498	NUT, 5/16-18 REGHEXCTRLK .....	4
38	180077	SCREW, 5/16-18 X .75 HHC .....	1
39	1498	NUT, 5/16-18 REGHEXCTRLK .....	1
40	301238	QUADRANT, HEIGHT ADJUST .....	1
41	180077	SCREW, 5/16-18 X .75 HHC .....	2
42	1498	NUT, 5/16-18 REGHEXCTRLK .....	2
43	322292-853	HANDLE, LIFT SHORT (30" S.F.) .....	1
44	300171	BOLT, .500 X .270 HSSH 5/16-18 .....	1
45	996418	WASHER, FLAT .506 X .75 X .024 .....	1
46	44108	NUT, 5/16-18 HWDFLCTRLK .....	1
47	301239	PAWL, SQUARE .....	1
48	300171	BOLT, .500 X .270 HSSH 5/16-18 .....	1
49	44108	NUT, 5/16-18 HWDFLCTRLK .....	1
50	9435	POINTER, HEIGHT ADJUST .....	1
51	138479	WASHER, EXLK .195 X .41 X .03 .....	1
52	35287	SCREW, #8-32 X .38 HHWATAP .....	1
53	303027	ROD, ACTUATOR-SHORT .....	1
54	58326	SPRING, HEIGHT ADJUST .....	1
55	58325	KNOB, HEIGHT ADJUST PUSH BUTTON .....	1
56	58329	GRIP, .750 OD W/ HOLE BLACK .....	1
57	9149	BRACKET, CABLE RETAIN .....	1
58	48306	PULLEY, POWDER METAL .....	1
59	58336	BOLT, .375 X .375 HSSH 1/4-20 .....	1
60	1502	NUT, 1/4-20 REGHEXCTRLK .....	1
61	314177	CABLE, LIFT 22.92 F-5 20 X 8-8 .....	1
62	300310	PIN, CLEVIS .310 DIA + .475 LG .....	1
63	300311	RING, RET E .31 X .25 TRU X 5133-31 .....	1
64	120375	NUT, 1/4-20 REGHEX .....	1
65	48306	PULLEY, POWDER METAL .....	1
66	300317	PIN, CLEVIS .375 DIA X .81 LG .....	1
67	8260	PIN, HAIR .091 DIA X 1.66 LG .....	1
68	9405	CLEVIS, LIFT CABLE .....	1
69	120372	NUT, 1/4-20 REGSQ .....	1
70	39522	PIN, CLEVIS .312 X .812 .....	1
71	121222	PIN, COTTER .090 DIA X .75 LG .....	1
72	300335	LIFT COVER-39" F5 .....	1
73	300340	SCREW, #10 X .75 HHPLAST BLK .....	3
74	55514	KNOB, ROUND 1.50 DIA BLACK .....	1

# E3560-820

# REPAIR PARTS

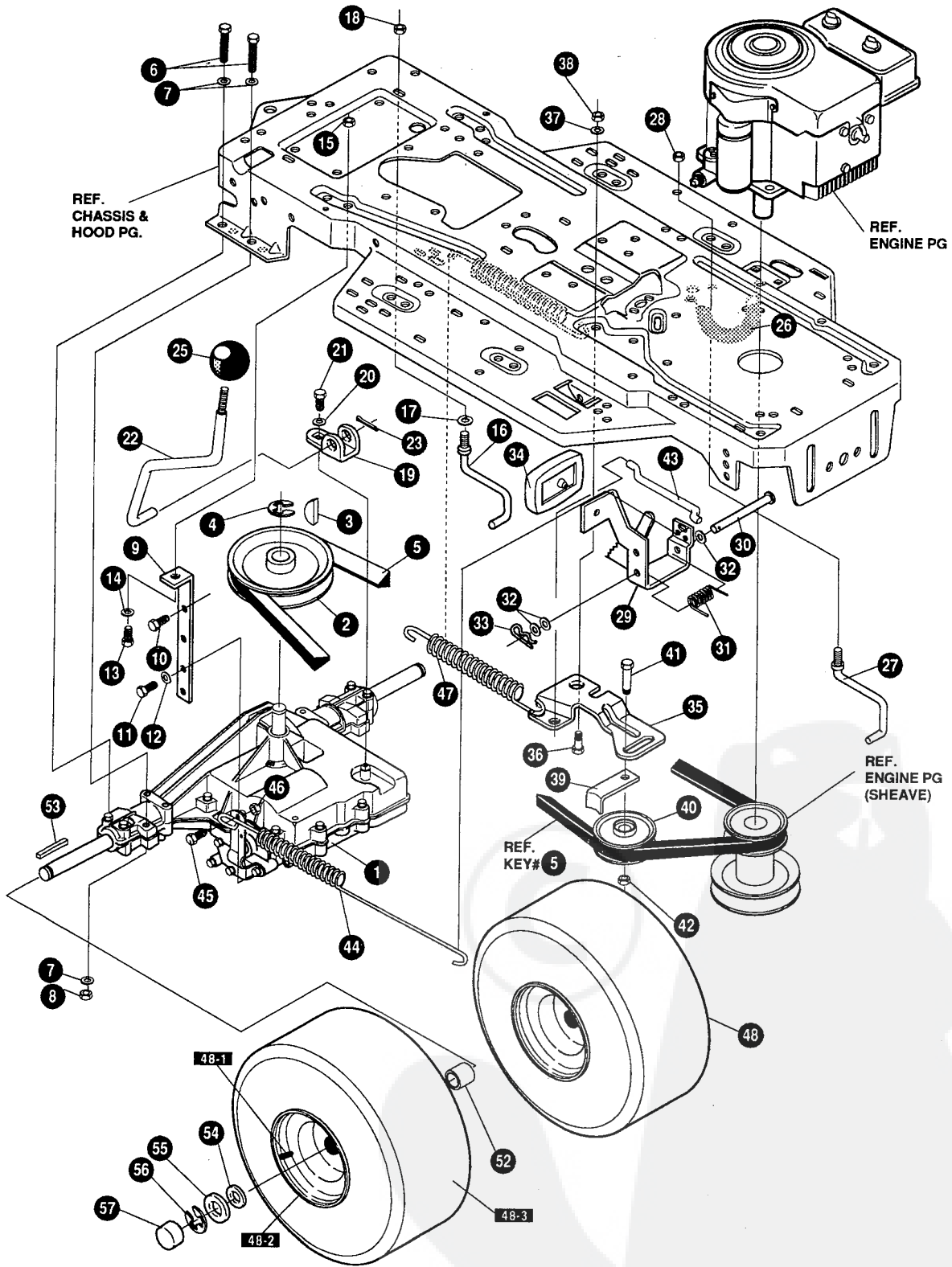

**NOTE: ALWAYS USE ORIGINAL EQUIPMENT PARTS.** Use of service/replacement parts other than original equipment parts may void your warranty.

**ALL UNNUMBERED ITEMS ARE INTERCHANGEABLE WITH OPPOSITE SIDE**

328261 D

# E3560-820

# MOTION DRIVE ASSEMBLY

KEY#	PART#	DESCRIPTION	QTY
1	^	TRANSAXLE, FOOTE 4360-5 .....	1
2	302745	PULLEY, 6.6 OD V4L T/A .....	1
3	50795	KEY, HI-PRO 606 .75 DIA X .187 WD .....	1
4	22053	RING, RETEX .58 X .035 TRU 5100-62 .....	1
5	314120	BELT, V 4L 87.25 4WS LF .....	1
6	180113	SCREW, 5/16-18 X 3.00 HHC .....	4
7	120393	WASHER, FLAT .344 X .69 X .065 .....	8
8	1498	NUT, 5/16-18 REGHEXCTRLK .....	4
9	323739	BRACKET, STABILIZER BLK .....	1
10	50947	SCREW, 3/8-16 X 1.25 WAHHTAPBLKP .....	1
11	35498	SCREW, 5/16-18 X .75 WAHHTAP .....	1
12	120638	WASHER, HVSP TLK .328 X .60 X .09 .....	1
13	180079	SCREW, 5/16-18 X 1.00 HHC .....	1
14	120393	WASHER, FLAT .344 X .69 X .065 .....	1
15	1498	NUT, 5/16-18 REGHEXCTRLK .....	1
16	57259	GUIDE, BELT 5/16-18 THD .....	1
17	138538	WASHER, REGINTLK .320 X .61 X .03 .....	1
18	1498	NUT, 5/16-18 REGHEXCTRLK .....	1
19	57480	BRACKET, SHIFT P920-5 .....	1
20	57157	WASHER, .750 X .250 SP-TRANSAXLE .....	1
21	56255	SCREW, 1/4-28 X .75 NYLHHC .....	1
22	302743	LEVER, SHIFT FOOT 4360-5&6 LF .....	1
23	137185	PIN, COTTER .125 DIA X 1.00 LG .....	1
25	55514	KNOB, ROUND 1.50 DIA BLACK .....	1
26	321514	SPRING, DRAG LINK BIAS .....	1
27	304016	GUIDE, BELT RH .....	1
28	1498	NUT, 5/16-18 REGHEXCTRLK .....	1
29	325942	PEDAL ASSEMBLY, BRAKE/CLUTCH LF .....	1
30	319675	PIN, CLEVIS .500 D X 4.53 LG .....	1
31	57847	SPRING, BRAKE PEDAL .....	1
32	2968	WASHER, FLAT .504 X .75 X .059 .....	3
33	56180	PIN, HAIR .091 DIA X 1.62 LG .....	1
34	48160	PAD, CLUTCH BRAKE W/PRINTING .....	1
35	320381-853	ARM, IDLER TRACTION, SOG, LF .....	1
36	329989	BOLT, .625 X .135 HHSH 5/16-18 .....	1
37	45602	WASHER, FLAT .333 X .87 X .119 .....	1
38	1498	NUT, 5/16-18 REGHEXCTRLK .....	1
39	39659	RETAINER, BELT .....	1
40	35374	PULLEY, IDLER V4L 3.06 X .62 .....	1
41	45892	BOLT, 3/8-16 X 1.50 CARRSN .....	1
42	1499	NUT, 3/8-16 REGHXCTRLK .....	1
43	57204	ROD, CLUTCH 3.92" .....	1
44	325937	SPRING, BRAKE 28.80 930, 4360 .....	1
45	326131	BOLT, .495 X .31 HHSH5/16-18 .....	1
46	1498	NUT, 5/16-18 REGHEXCTRLK .....	1
47	330505	SPRING, CLUTCH .113 X .750 X 8.75 .....	1
48	57166	TIRE & RIM, 20 X 8.00-8 .....	2
48-1	24167	VALVE STEM	
48-2	57165	RIM, WHEEL	
48-3	TIRE	REFER TO TIRE TREAD PAGE	
52	57479	SPACER, SLEEVE .75 X 1.25 X 1.32 .....	2
53	52928	KEY, SQUARE .187 SQ X 2.25 LG .....	2
54	642	WASHER, FLAT .755 X 1.31 X .075 .....	4
55	42815	WASHER, FLAT .755 X 1.53 X .07 .....	2
56	36625	RING, RETEX .57 X .05 TRU 5133-75 .....	2
57	40394	HUB CAP, 1.500 ID X 7/8 LG .....	2

^ CONTACT YOUR NEAREST TRANSAXLE DEALER FOR PARTS & SERVICE

# E3560-820

# REPAIR PARTS

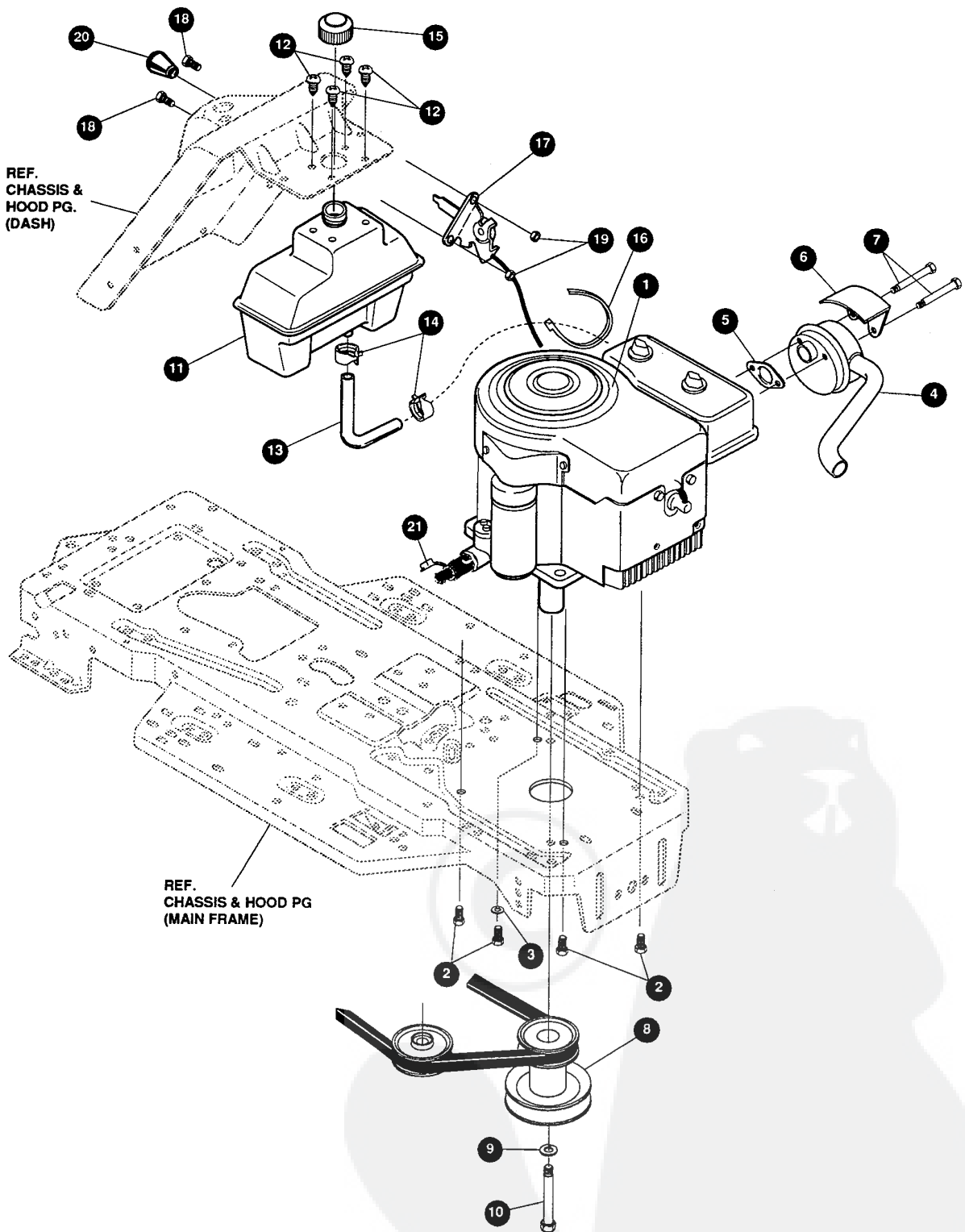

**NOTE:** ALWAYS USE ORIGINAL EQUIPMENT PARTS. Use of service/replacement parts other than original equipment parts may void your warranty.

**ALL UNNUMBERED ITEMS ARE INTERCHANGEABLE WITH OPPOSITE SIDE**

326187 D

**E3560-820****ENGINE & CONTROL ASSEMBLY**

KEY#	PART#	DESCRIPTION	QTY
1	ENGINE	12-12.5HP BS IC DUAL(SEE ENGINE MANUAL) .....	1
2	50947	SCREW, 3/8-16 X 1.25 WAHHTAPBLKP .....	4
3	138489	WASHER, EXLK .384 X .69 X .04 .....	1
4	305367	MUFFLER-LO TONE, NELSON EXPORT .....	1
5	46708	GASKET, MUFFLER .....	1
6	54767	SHIELD, HEAT, FOR ROUND MUFFLER .....	1
7	54980	SCREW, 5/16-18 X 3.50 HHC .....	2
8	328028	PULLEY, ENGINE 3.0D X 4.0 LG X 5.0 D .....	1
9	120383	WASHER, REGSPTLK .459 X .78 X .12 .....	1
10	433146	SCREW, 7/16-20 X 4.25 HHC BLK PH .....	1
11	314989	TANK, FUEL 1 GAL CLEAR .....	1
12	49050	SCREW, 1/4-10 X .75PHPNTAP .....	4
13	50118	TUBING, .25 X .50 X BULK GAS LINE .....	13.0"
14	47345	CLAMP, HOSE SCREW TYPE .....	2
15	46704	CAP, GAS 1-1/2-7 THD BLK .....	1
16	57444	TIE, CABLE BLACK NYLON 5.62L .....	1
17	321273	CONTROL, THROTTLE 12-12.5HP LF .....	1
18	320553	SCREW, 10-24 X .63 PHPNMA CRSS .....	2
19	308459	NUT, #10-24 HXHDNYLK .....	2
20	50607	KNOB, ROUND THROTTLE BLACK .....	1
21	325547	OIL DRAIN VALVE ASSEMBLY .....	1

# E3560-830

# REPAIR PARTS

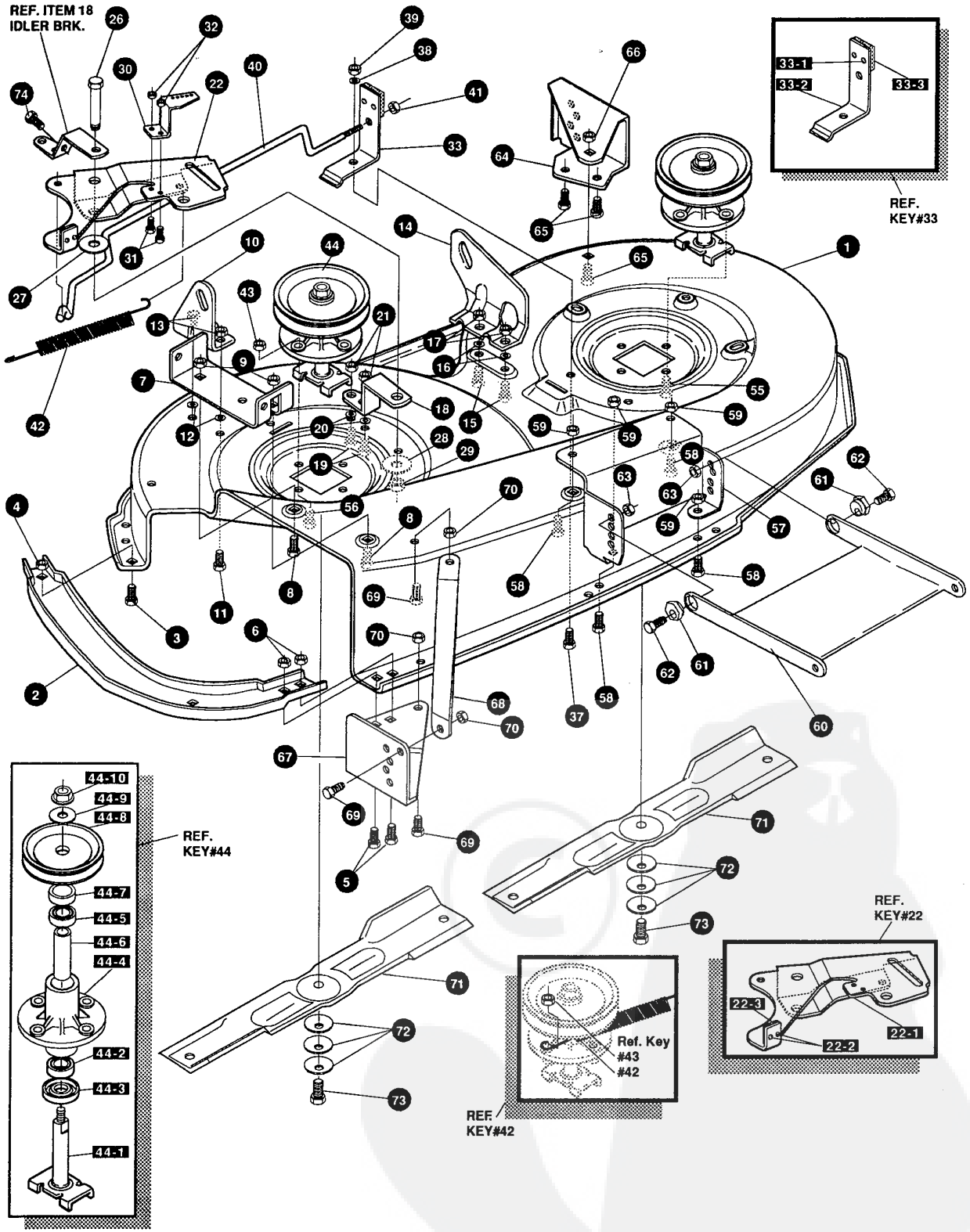

**NOTE:** ALWAYS USE ORIGINAL EQUIPMENT PARTS. Use of service/replacement parts other than original equipment parts may void your warranty.

**ALL UNNUMBERED ITEMS ARE INTERCHANGEABLE WITH OPPOSITE SIDE**

320109 H



# E3560-830

# PRE-PAINTED DECK ASSEMBLY

KEY#	PART#	DESCRIPTION	QTY
1	325103	40" DECK KIT	1
2	326480-853	TOE GUARD - MULCHER	1
3	180077	SCREW, 5/16-18 X .75 HHC	1
4	1498	NUT, 5/16-18 REGHEXCTRLK	1
5	180077	SCREW, 5/16-18 X .75 HHC	2
6	1498	NUT, 5/16-18 REGHEXCTRLK	2
7	317017	BRACKET, CHUTE MOUNT BLACK	1
8	180077	SCREW, 5/16-18 X .75 HHC	2
9	1498	NUT, 5/16-18 REGHEXCTRLK	2
10	313929	LIFT BRACKET, REAR RH BLK 853	1
11	180077	SCREW, 5/16-18 X .75 HHC	2
12	120393	WASHER, FLAT .344 X .69 X .065	2
13	1498	NUT, 5/16-18 REGHEXCTRLK	2
14	310667	BRACKET, DECK LIFTREAR LH BLK	1
15	180077	SCREW, 5/16-18 X .75 HHC	2
16	120393	WASHER, FLAT .344 X .69 X .065	2
17	1498	NUT, 5/16-18 REGHEXCTRLK	2
18	326893-853	BRACE, IDLER SUPPORT 40", 43"	1
19	180077	SCREW, 5/16-18 X .75 HHC	2
20	120393	WASHER, FLAT .344 X .69 X .065	2
21	44108	NUT, 5/16-18 HWDFLCTRLK	2
22	320576-853	IDLER ARM ASSEMBLY	1
22-1	322116-853	ARM, IDLER 40/43" DECK	1
22-2	41601	RIVET, OVSET .187 DIA X .50 LG ST	2
22-3	306973	BRAKE PAD - HARD - 232AF	1
26	304420	BOLT, .500 X 2.15 HSSH	1
27	996307	WASHER, FLAT .391 X 1.00 X .209	1
28	996416	WASHER, FLAT .391 X 1.00 X .125	2
29	45171	NUT, 3/8-16 HWDFL WHIZ-LOCK	1
30	326249-853	BRACKET, EXTENSION IDLER	1
31	180077	SCREW, 5/16-18 X .75 HHC	2
32	1498	NUT, 5/16-18 REGHEXCTRLK	2
33	321828	BLADE BRAKE ASSEMBLY	1
33-1	135624	RIVET, TRSET .185 DIA X .41 LG ST	2
33-2	304119-853	BRAKE ARM	1
33-3	306973	BRAKE PAD - HARD - 232AF	1
37	180077	SCREW, 5/16-18 X .75 HHC	1
38	120393	WASHER, FLAT .344 X .69 X .065	1
39	1498	NUT, 5/16-18 REGHEXCTRLK	1
40	302714	ROD, BRAKE	1
41	1502	NUT, 1/4-20 REGHEXCTRLK	1
42	35410	SPRING, .071 X .62 X 4.37	1
43	1498	NUT, 5/16-18 REGHEXCTRLK	1
44	56424-853	QUILL ASSEMBLY, 36/39/40/43	2
44-1	56425	SHAFT/SADDLE 36"	1
44-2	49562	BEARING, BALL 6203-2AA(SEALS)-C3	1
44-3	50616	DUST SHIELD	1
44-4	55547	QUILL CASTING (1046)	1
44-5	49562	BEARING, BALL 6203-2AA (SEALS)-C3	1
44-6	50818	SPACER, SLEEVE .669 X .88 X 3.797	1
44-7	51449	SPACER, SLEEVE .672 X .93 X .438 PM	1
44-8	313898	PULLEY ASSEMBLY	1
44-9	56365	WASHER, SPECIAL QUILL	1
44-10	1282	NUT, 7/16-20 WDFLLK	1
55	35498	SCREW, 5/16-18 X .75 WAHHTAP	7
56	300345	SCREW, 5/16-18 X 1.38 WAHHTAP	1
57	318445-853	BRACKET, 40 LF FRONT DECK	1
58	180077	SCREW, 5/16-18 X .75 HHC	4
59	1498	NUT, 5/16-18 REGHEXCTRLK	4
60	58305-853	BRACKET, LINK DECK FRONT	1
61	58247	NUT, ADJUST	2
62	180079	SCREW, 5/16-18 X 1.00 HHC	2
63	1498	NUT, 5/16-18 REGHEXCTRLK	2
64	317041	BRACKET, GAGE WHEEL LH BLACK	1
65	180077	SCREW, 5/16-18 X .75 HHC	3
66	1498	NUT, 5/16-18 REGHEXCTRLK	3
67	322464-853	BRACKET, GAGE WHEEL RH FRONT	1
68	314282-853	BRACKET, STABILIZER	1
69	180077	SCREW, 5/16-18 X .75 HHC	3
70	1498	NUT, 5/16-18 REGHEXCTRLK	3
71	313316	BLADE, 40" STD-LIFT 20.32BLK	2
72	2483	WASHER, .39 ID X 1.25 D X .07 BELLVIL	6
73	39573	SCREW, 3/8-24 X 1.00 NYLHHC	2
74	308231	SCREW, 1/4-20 X 1.25 HHWATAP	1

# E3560-820

# REPAIR PARTS

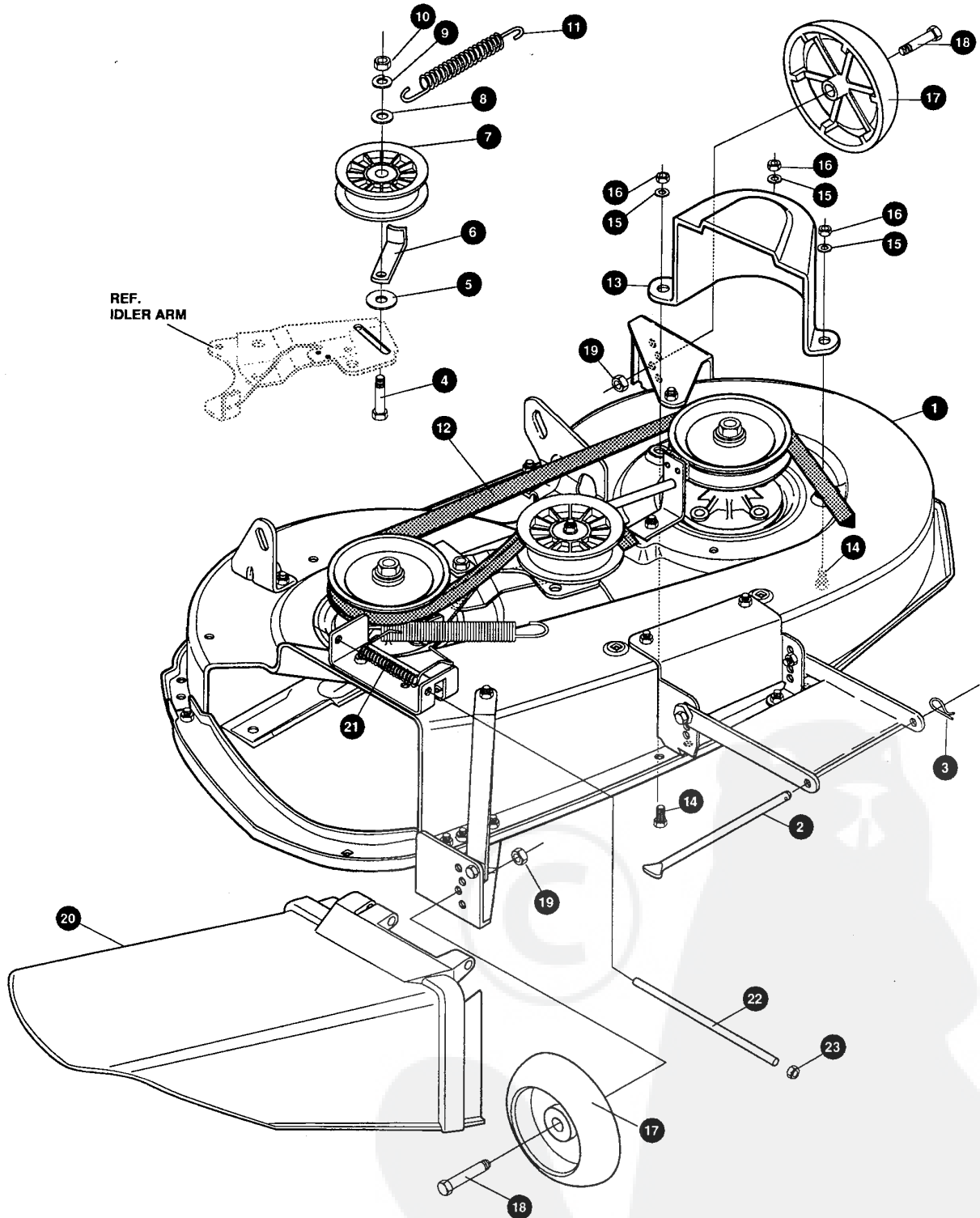

**NOTE:** ALWAYS USE ORIGINAL EQUIPMENT PARTS. Use of service/replacement parts other than original equipment parts may void your warranty.

**ALL UNNUMBERED ITEMS ARE INTERCHANGEABLE WITH OPPOSITE SIDE**

325682 B

KEY#	PART#	DESCRIPTION	QTY
1	329035	ASSEMBLY, 40"SUS DECK EXPORT .....	1
2	58306	ROD, DECK HITCH .....	1
3	8260	PIN, HAIR .091 DIA X 1.66 LG .....	1
4	57325	BOLT, 3/8-16 X 2.00 CARRSN .....	1
5	25210	WASHER, FLAT .386 X 1.25 X .09 .....	1
6	1346	RETAINER, BELT .....	1
7	310326	PULLEY, IDLER BFF 4.00 WIDE FL .....	1
8	996307	WASHER, FLAT .391 X 1.00 X .209 .....	1
9	120382	WASHER, REGSPTLK .393 X .68 X .10 .....	1
10	120377	NUT, 3/8-16 REGHX .....	1
11	300473	SPRING, TENSION 7.52 LG + 17 LB/IN .....	1
12	319005	BELT, V 5L 81.00 DECK 40 LF .....	1
13	328257	GUARD, BELT LH PLASTIC .....	1
14	180077	SCREW, 5/16-18 X .75 HHC .....	3
15	120393	WASHER, FLAT .344 X .69 X .065 .....	3
16	1498	NUT, 5/16-18 REGHEXCTRLK .....	3
17	302611	GAUGE WHEEL, EURO 6.00 OD X 1.38 WD .....	2
18	23763	BOLT, .500 X 1.390 HHSH 3/8-16 .....	2
19	1499	NUT, 3/8-16 REGHXCTRLK .....	2
20	304422	CHUTE DEFLECTOR, 40", 42" & 43" .....	1
21	314975	SPRING, TORSION CHUTE DEFLECTOR .....	1
22	304424	ROD, PIVOT DECK .312 D X 7.25 .....	1
23	3535	NUT, PUSH ON CAP .312 OD .....	1

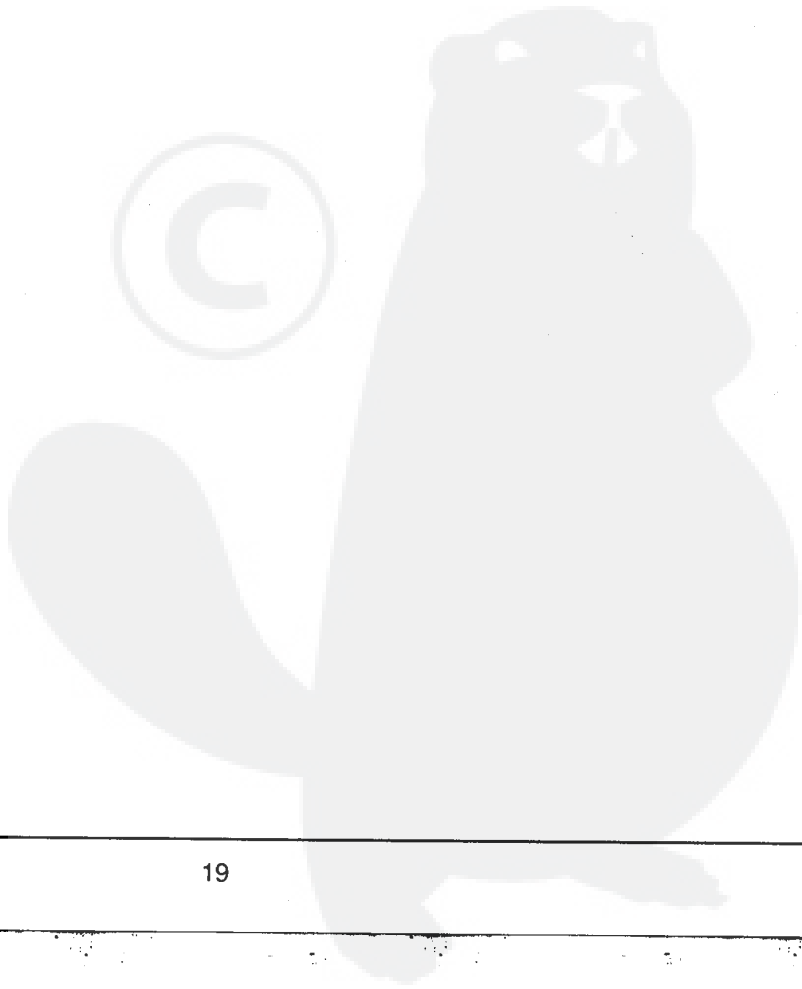
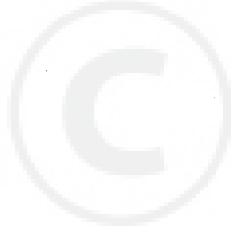

# E3560-820

# REPAIR PARTS

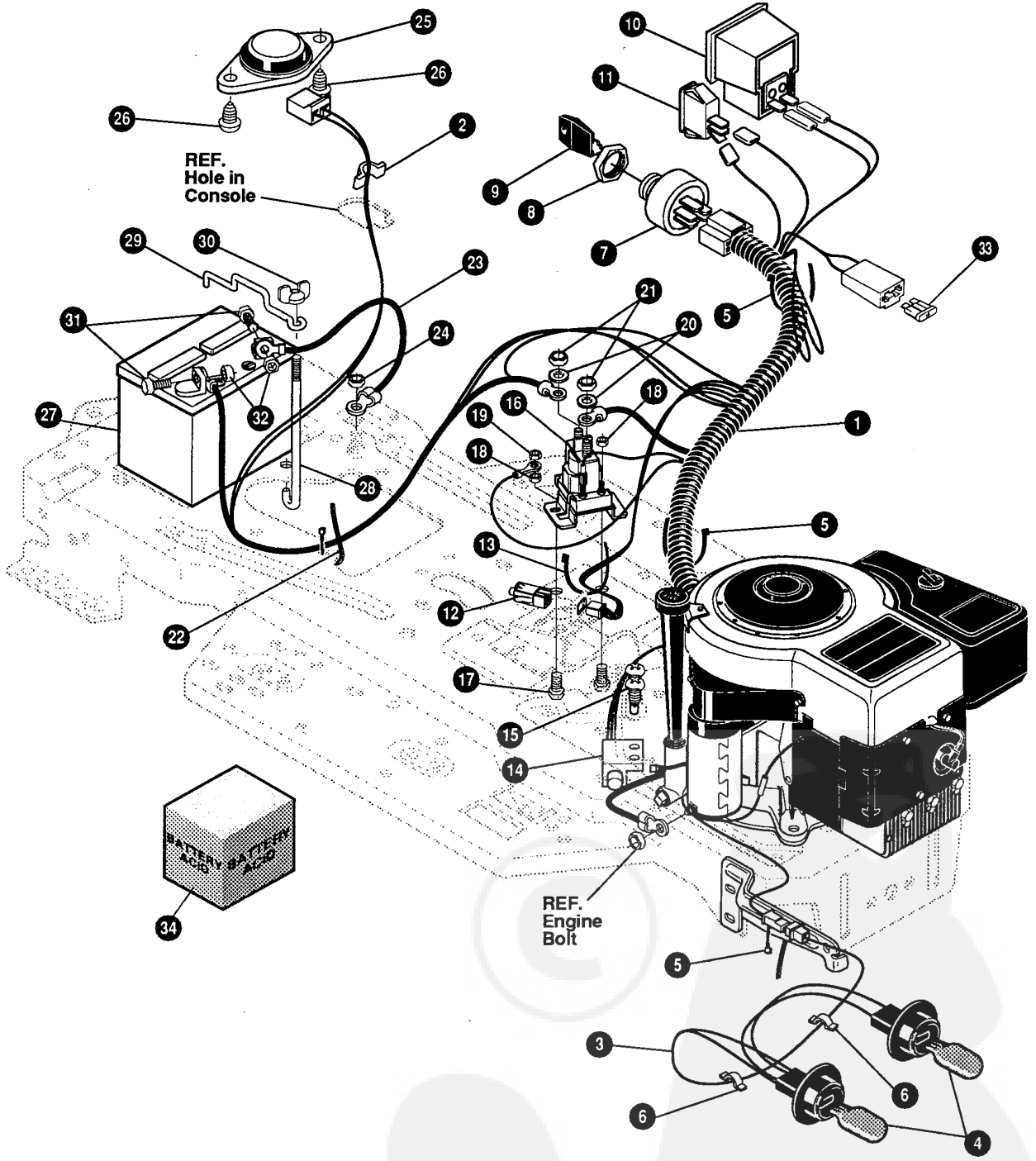

**NOTE:** ALWAYS USE ORIGINAL EQUIPMENT PARTS. Use of service/replacement parts other than original equipment parts may void your warranty.

**ALL UNNUMBERED ITEMS ARE INTERCHANGEABLE WITH OPPOSITE SIDE**

325502 C

KEY#	PART#	DESCRIPTION	QTY
1	320065	HARNES, 12-12.5BS, H14, WRAP, LF .....	1
2	41482	PRESS CLIP, 1.380 LG .255 ID .....	1
3	303064	ASSEMBLY, LIGHT WIRE-1/4 TURN .....	1
4	52572	BULB, HEADLAMP .....	2
5	57444	TIE, CABLE BLACK NYLON 5.62L .....	3
6	41482	PRESS CLIP, 1.380 LG .255 ID .....	2
7	327355	SWITCH-IGNITION (AFTER FIRE) 3 POSITION .....	1
8	327352	NUT, 5/8-8 ACME DELTA FOR BOOT .....	1
9	327350	KEY, IGNITION DELTA .....	2
10	300133	AMMETER .....	1
11	300334	LIGHT SWITCH, ON/OFF PANEL MOUNT .....	1
12	320082	SWITCH, DOUBLE POLE NO/NC GRAY .....	1
13	57444	TIE, CABLE BLACK NYLON 5.62 L .....	1
14	57476	SWITCH, SCREW MOUNT DP NC NO BLK .....	1
15	57220	SCREW, #12 X .50 PHPNHTAP BLK .....	2
16	53716	SOLENOID .....	1
17	187745	SCREW, 1/4-20 X .75 HXSEMMA .....	2
18	1502	NUT, 1/4-20 REGHEXCTRLK .....	2
19	271172	NUT, 1/4-20 REGHEXKEPS .....	1
20	138485	WASHER, EXLX .320 X .61 X .03 .....	2
21	120368	NUT, 5/16-24 REGHEX .....	2
22	57444	TIE, CABLE BLACK NYLON 5.62 L .....	1
23	55511	WIRE, GROUND, 12.5" .....	1
24	271184	NUT, 5/16-18 HEXKEPS .....	1
25	57547	SWITCH, SEAT .....	1
26	160505	SCREW, 1/4-20 X .38 PHPNHMA .....	2
27	302257	BATTERY, 12V .....	1
28	57551	ROD, BATTERY .....	1
29	57552	ROD, BATTERY, TOP .....	1
30	325232	NUT, WING 1/4-20 NYLON .....	1
31	180020	SCREW, 1/4-20X .75 HHC .....	2
32	271172	NUT, 1/4-20 REGHEXKEPS .....	2
34	^	BATTERY ACID PACK, 80 OZ .....	1

^ CAN BE PURCHASED LOCALLY

## WIRING SCHEMATIC

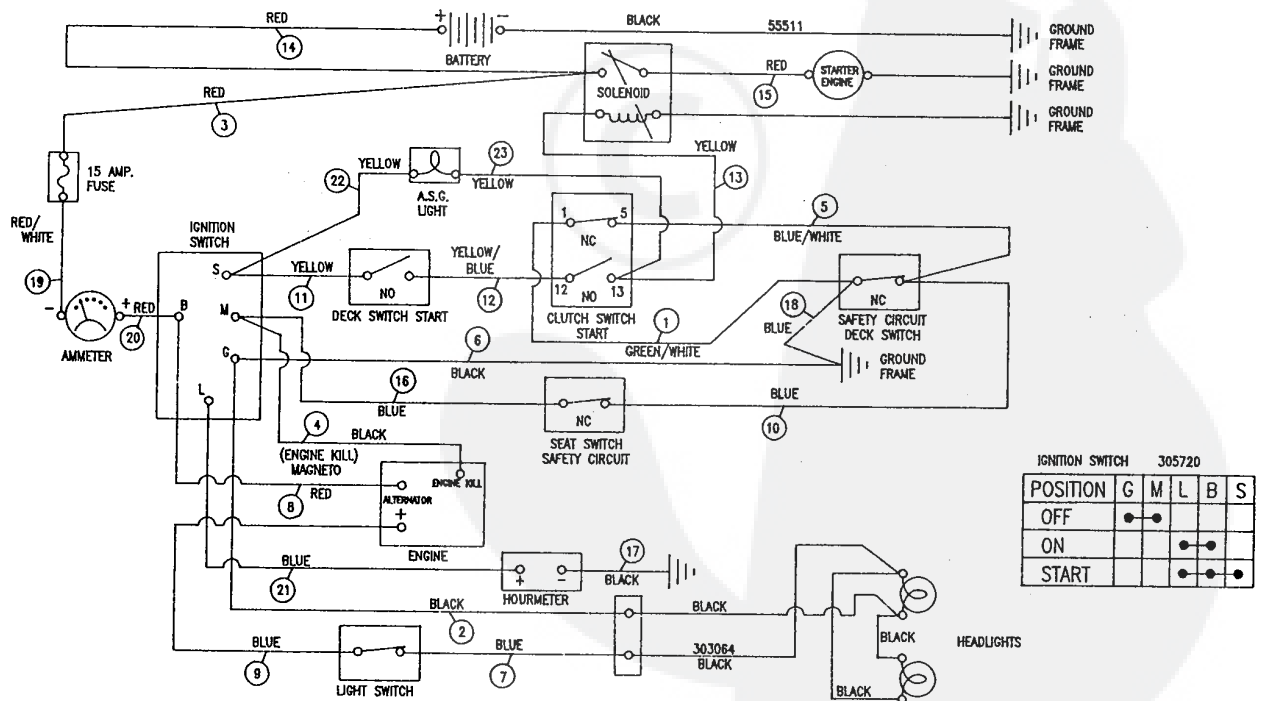

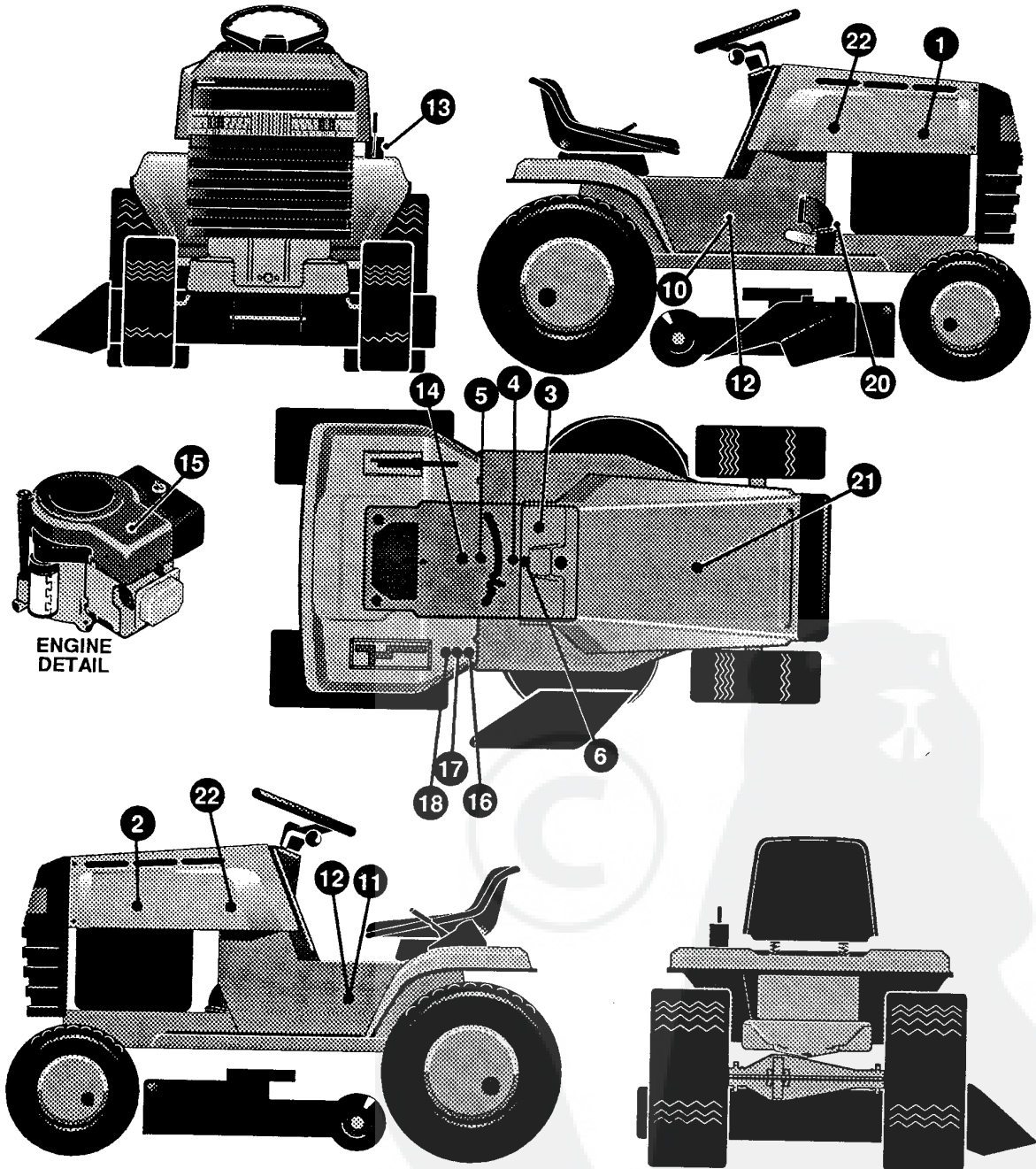

# E3560-820

# DECAL ASSEMBLY

KEY#	PART#	DESCRIPTION	QTY
1	314456	DECAL, HOODSIDE RH H-21 .....	1
2	314457	DECAL, HOODSIDE LH H-21 .....	1
3	321765	DECAL, LF DASH, PTO/LIGHT SW EXP .....	1
4	307383	DECAL, INSTRUCT CONSOLE TOP ENGL .....	1
5	69525	DECAL, INSTRUCT CONSOLE TOP FR .....	1
6	69524	DECAL, INSTRUCT CONSOLE TOP GER .....	1
10	314462	DECAL, CONSOLE RH LARGE FRAME .....	1
11	314463	DECAL, CONSOLE LH LARGE FRAME .....	1
12	322326	NAMEPLATE, 12.5/40 WHITE .....	2
13	402214	DECAL, HEIGHT ADJUST .....	1
16	305770	DECAL, CAUTION TRIANGLE EUROPE .....	1
17	68902	DECAL, WARNING, FRENCH/GERMAN .....	1
18	310553	DECAL, DANGER ENGLISH .....	1
20	68903	DECAL, BRAKE/CLUTCH ISO .....	1
21	55835	PAD, FOAM HOOD TOP H-6/7 .....	1
22	55836	PAD, FOAM HOOD SIDE H-6/7 .....	2

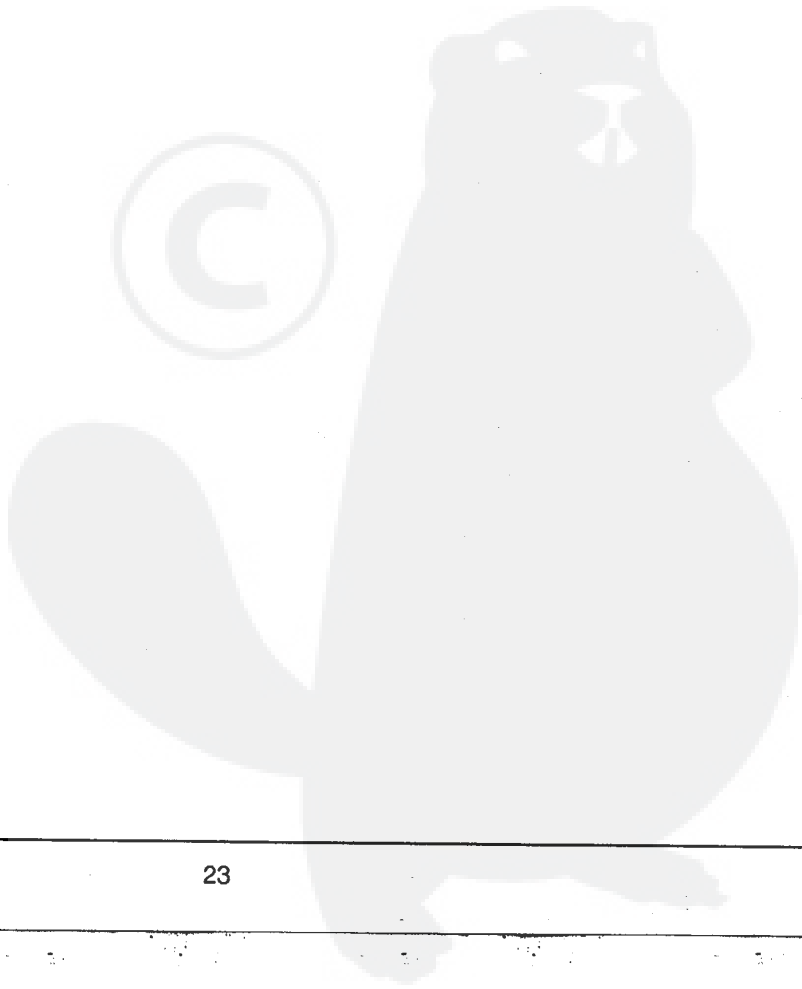
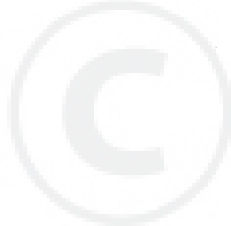

# TREAD PATTERNS

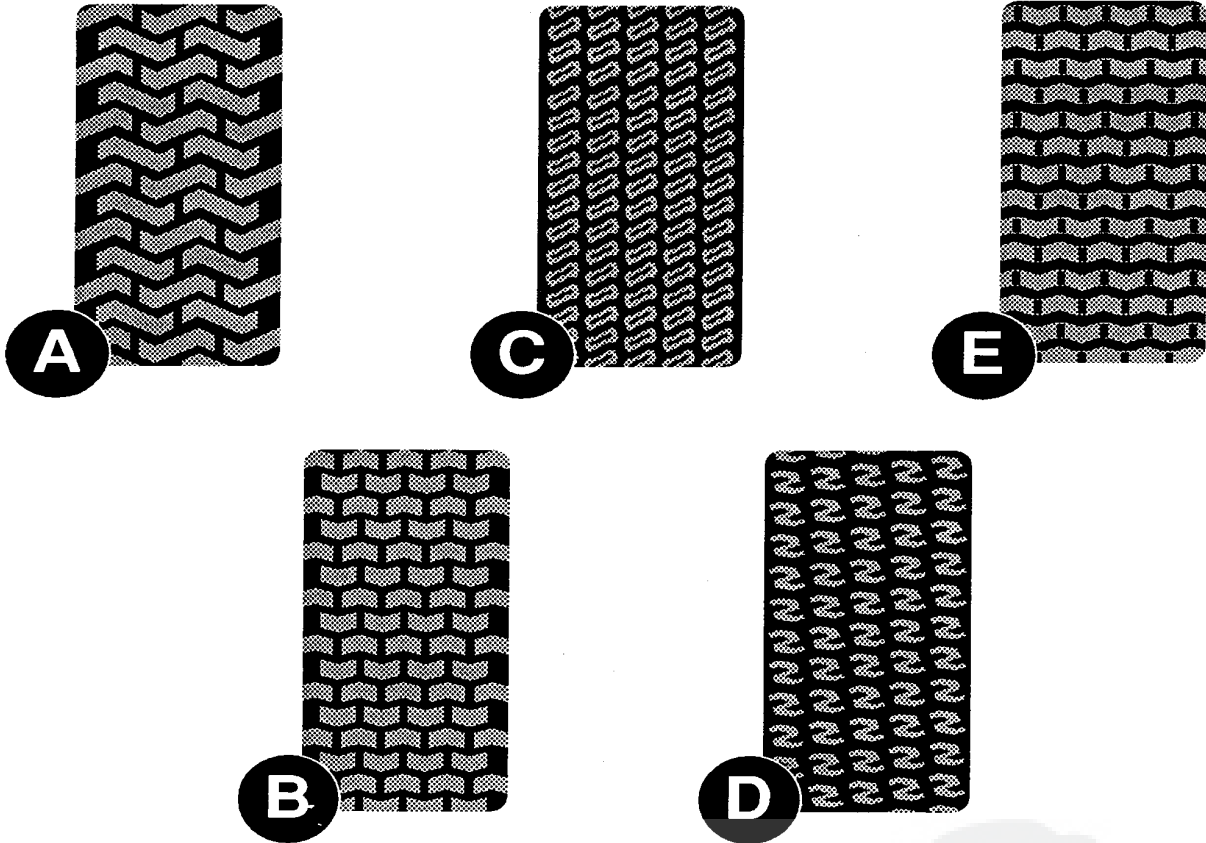

TIRE SIZE	"A"	"B"	"C"	"D"	"E"
11 X 4.00 - 5	42295	319679			
13 X 5.00 - 6	41060	319680			
15 X 6.00 - 6	39830	316702	301140	313952	
16 X 4.80 - 8		305035			
16 X 6.50 - 8	41081	319682		314539	
18 X 6.50 - 8		42091			
18 X 8.50 - 8	319683	317400			
18 X 9.50 - 8	41106	316701		313950	
20 X 8.00 - 8	319685	319684	57164	314584	331606
20 X 10.00 - 8	58276	319686		313654	
20 X 10.00 - 10	55893	319687			
23 X 9.50 - 12	53655	319690	319689	314370	



Contact the dealer where your tractor was purchased for the available accessories. If you are unable to contact the dealer, write to the address on the front cover of this manual.

**Large Lawn Tractor**

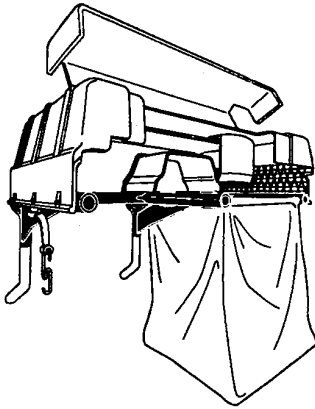

**Model # 5708-34**  
Grass Collector for  
40, 42, 43" decks

For heavy duty grass  
collection order Model  
#5709-10 Air Assist

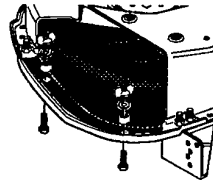

**5717-00**  
Mulching Kit (42/43" Deck)  
**5716-00**  
Mulching Kit (40" Deck)

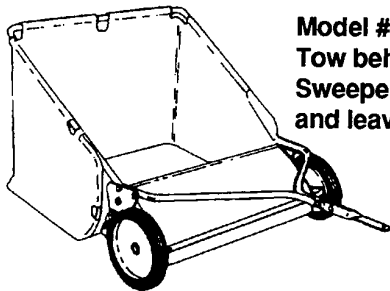
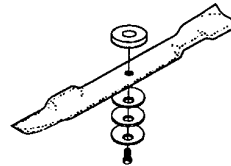

**Model # 5648-16**  
Tow behind Lawn  
Sweeper for grass  
and leaves

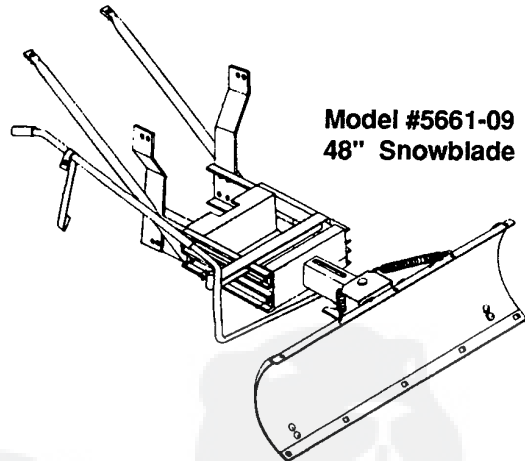

**Model #5661-09**  
48" Snowblade

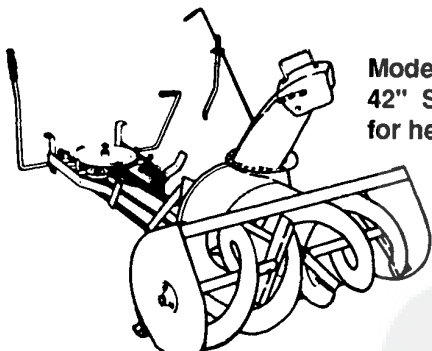

**Model #5705-06**  
42" Snowthrower  
for heavy snowfall

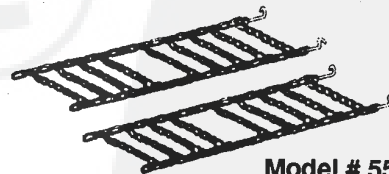

**Model # 5585-00**  
Tire Chains - 20" x 8.0" tires  
**Model # 5706-00**  
Tire Chains - 20" x 10.0" tires

**OTHER ACCESSORIES**

Model	Description
5672-01	Wheel Weights - Front - 1 pr. w/mtg. hdw. - Fits 15" tires
5673-02	Wheel Weights - Rear - 1 pr. w/mtg. hdw. - Fits 18" & 20" tires
316608	43" High Lift Blade for Bagging or Side Discharge (Requires 2)
325762	43" Mulching Blade (Requires 2)

### **ONE YEAR LIMITED WARRANTY**

For one (1) year from date of purchase by the first consumer for residential use (**thirty (30) days commercial use**), NOMA Outdoor Products Incorporated warrants that it will replace free of charge, including labor, any original part of any NOMA Outdoor Products Incorporated product found to be defective by any authorized Service Dealer or the factory, except the battery which is warranted for ninety (90) days from date of purchase.

This warranty does not cover engine, transmission, transaxle or differential (**these items are covered by their manufacturer's own warranty**). This warranty does not cover parts that have failed due to normal wear or parts that have failed subject to misuse or abuse. Transportation of the unit or part to and from an authorized Service Dealer or factory is the responsibility of the owner.

A step by step explanation as to what procedure should be followed for this warranty is:

1. If a part becomes defective, contact the store where the unit was purchased for the name and address of the authorized Service Dealer nearest to you.
2. If you cannot locate an authorized Service Dealer, write Service Department of NOMA Outdoor Products Incorporated for the name and address of the authorized Service Dealer in your area or call the Service Department at 1-901-422-1690.
3. Return the defective product, along with proof of purchase to such authorized Service Dealer for replacement of any defective part where covered by this warranty.

There is no other express warranty. Implied warranties, including those of merchantability and fitness for a particular purpose are limited to one (1) year from date of purchase. Liability for incidental or consequential damages are excluded.

Some states do not allow limitations on how long an implied warranty lasts, so the above limitation may not apply to you. Some states do not allow the exclusion of incidental or consequential damages, so the above exclusion may not apply to you. This warranty gives you specific legal rights, and you may have other rights which vary from state to state.

**NOMA Outdoor Products Incorporated**

**Caller 8000**

**Jackson, TN 38308-8000**

### **UNIT PARTS AND SERVICE**

Fill in and mail the registration card packed with the unit. For service other than covered in this manual, contact an authorized service dealer. A nationwide parts and service organization has been established to provide locally available parts and service. A list of authorized parts distributors has been included in this manual. When ordering repair parts, always give the following information: 1. The Part Name; 2. The Part Number; 3. The Quantity desired; 4. The Full (**eight digit**) Model Number of the unit. The model number will be found on a plate attached to the unit.

Look for this symbol.



**It means - ATTENTION! BECOME ALERT! A HAZARD TO OPERATOR, BYSTANDER, PROPERTY OR EQUIPMENT MAY EXIST.**

**NOMA Outdoor Products Incorporated  
Caller 8000  
Jackson, TN 38308-8000**