

NOTE: ALWAYS USE ORIGINAL EQUIPMENT PARTS. Use of service/replacement parts other than original equipment parts may void your warranty.

ALL UNNUMBERED ITEMS ARE INTERCHANGEABLE WITH OPPOSITE SIDE

325869 C

E3583-080

FRONT CHASSIS & HOOD ASSEMBLY

KEY#	PART#	DESCRIPTION	QTY
1	326569-853	BRACKET, GRILLE LH	1
2	56030	SCREW, 5/16-18X 75WDFLLK	2
3	55273	NUT, 5/16-18 HXWDFLLK	2
a	326568-853	BRACKET, GRILLE RH	1
5	58030	SCREW, 5/16-18X 75WDFLLK	2
6	55273	NUT, 5/16-18 HXWDFLLK	2
7	313541-853	BRACKET, FRONT AXLE	1
8	56030	SCREW, 5/16-18X 75WDFLLK	1
9	55273	NUT, 5/16-18 HXWDFLLK	1
10	300440	GUIDE, BELT, RIDER	1
11	1498	NUT, 5/16-18 REGHEXCTRLK	1
1 2	308207	BOLT, 625X2.18 HHSH 1/2-13	1
13	309008	NUT, 1/2-13 HEXJAM CTRLK	1
14	180138	SCREW, 3/8-16X3.00 HHC	2
15	2 4 6 3	WASHER, .3910X1.25DX .07 BELLVIL	2
16	1499	NUT, 3/8-16 REGHEXCTRLK	2
17	300635	GUIDE, BELT SHORT 15" WHEEL	1
18	124824	NUT, 5/16-18 HEXJAM	1
19	271190	NUT, 3/8-16 HEXKEPS	1
20	40763	RIVET, POP. 187DIA X 450LG, ST	3
2	1	35497 SCREW, 5/16-18X .50 WAHHTAP	2
2 2	995346	SCREW, 1/4-20X .50 WAHHTAP	10
23	309447-860	DASH STEEL, LF SUSP DYN	1
2 4	44811	SCREW, 1/4-20X 75 WAHHTAP	2
25	995346	SCREW, 1/4-20X .50 WAHHTAP	4
26	50352	NUT, 1/4-20 WDFLLK TOQLOCK	4
27	312306	BAFFLE, CONSOLE/ SOUND EXPORT LF	1
28	300314	SCREW, 1/4-20X 88WAHHTAP	2
29	1 2 0 3 9 2	WASHER, FLAT .281X .63X .065	2
30	1502	NUT, 1/4-20 REGHEXCTRLK	2
3	1	313021-853 GUIDE, HOOD SF&LF H13, H14, H15	2
32	3 2 1 1 5 9	HOOD, NOMA LARGE H-15	1
33	319986	DECAL, TAPE H15 8MIL VINYL	1
34	302670	LENS, HEADLAMP DYNA HOODS	1
36	180034	SCREW, 1/4-20X 1.50 HHC	2
37	120392	WASHER, FLAT .281X .63X .065	2
38	308532	BEARING, FLANGED PLASTIC HOOD	2
39	311245	WASHER, FLAT .250X .75X INSULATE	2
40	1502	NUT, 1/4-20 REGHEXCTRLK	2
41	49050	SCREW, 1/4-10X .75PHNTAP	1
a2	310748	LANYARD, HOOD 15 77LG-H15	1
4 3	301452	FOIL, HEAT REFLECTOR	6
44	311465	COVER, STEERING SHAFT	1
a5	330848	STEERING WHEEL	1
46	301413	SPACER, STEERING SHAFT	1
47	456378	PIN, SPRING 250DIA X 2.00LG HVQL	1
49	300492	FOIL, LENS DYNA HOOD REFLECTOR	1
50	333831	PARTS MANUAL	1
51	3 3 2 2 1 2	OPERATOR'S MANUAL (ENGLISH)	1
52	332213	OPERATOR'S MANUAL (FRENCH)	1
53	332214	OPERATOR'S MANUAL (GERMAN)	1

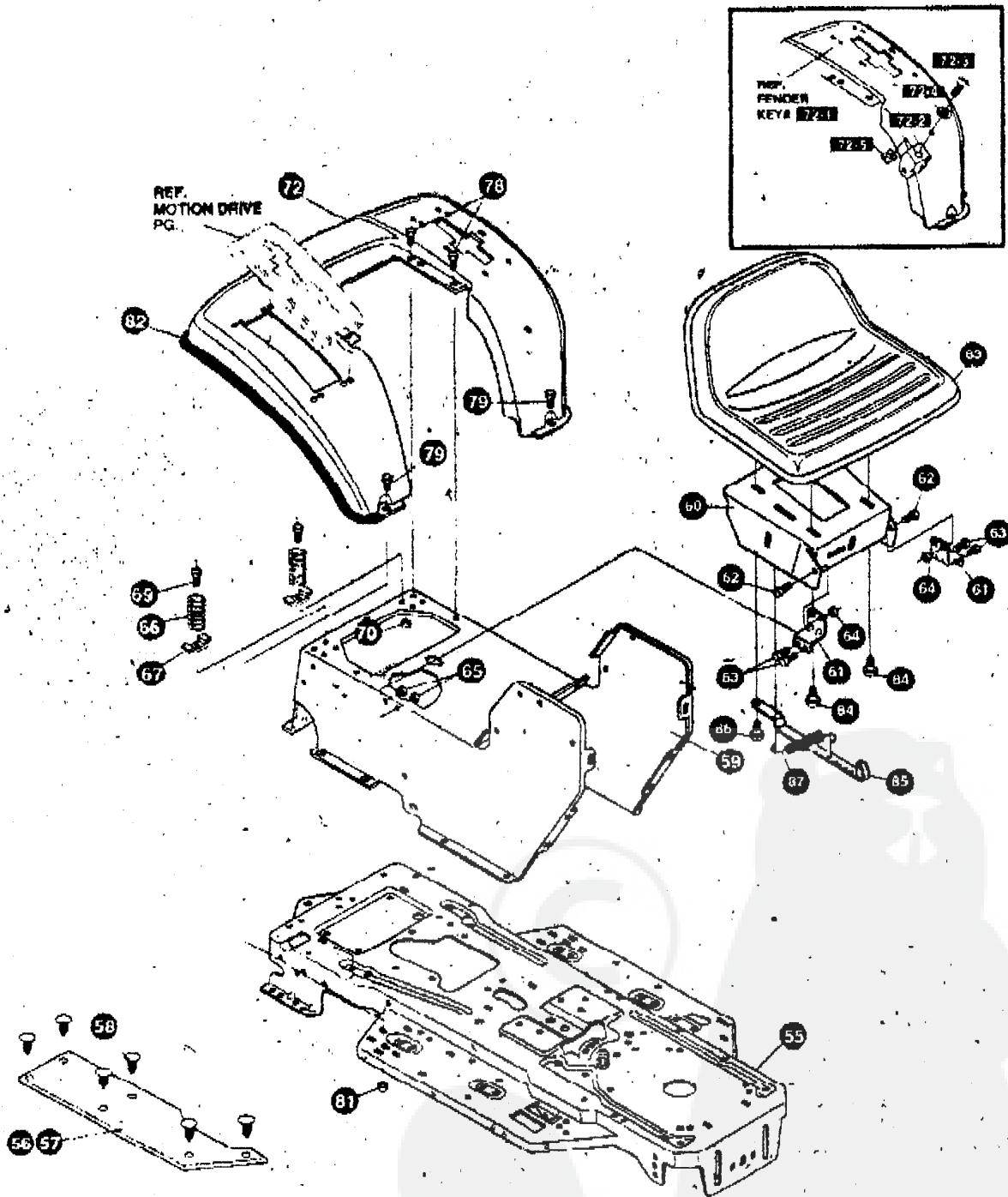

NOTE: ALWAYS USE ORIGINAL EQUIPMENT PARTS. Use of service/replacement parts other than original equipment parts may void your warranty.

ALL UNNUMBERED ITEMS ARE INTERCHANGEABLE WITH OPPOSITE SIDE

333755 A

KEY#	PART#	DESCRIPTION	QTY
55	325579-860	FRAME, LF DRILLED P920/F4360	1
56	310005	FOOT PAD, LH 22.12LG OYNA F5	1
57	310006	FOOT PAD, RH 22.12LG DYNA F5	1
58	309235	FASTENER, RATCHET BLACK	12
59	309665-860	CONSOLE, H14-15 SOF	1
60	332259-853	PLATE, SEAT F4 LF OK WELD	1
61	53746-853	BRACKET, SEAT SUPPORT F4 F5 SOG	2
62	20507	BOLT, 437X 166 HSH 5/16-18	2
63	1498	NUT, 5/16-18 REGHEXCTRLK	2
64	48901	SCREW, 5/16-18X .63WAHHC	4
65	1498	NUT, 5/16-18 REGHEXCTRCK	4
66	49335	SPRING, .250 X 1.75 X 4 50	2
67	7686	CLAMP, SPRING	2
69	44811	SCREW, 1/4-20X .75 WAHHTAP	2
70	1602	NUT, 1/4-20 REGHEXCTRLK	2
72	*	ASSEMBLY FENDER F5 LF SOF SUSP	1
72-1	332185-860	FENDER, F5, SUS, LF, SOF	1
72-2	9239	CLEVIS	1
72-1	438455	SCREW, 5/16-18X .56PHNMA	1
72-4	301661	WASHER, .3410X150DX .09 CU	1
72-5	120373	NUT, 5/16-18 SO	1
70	0 0 5 3 4 B	SCREW, 1/4-20X .50 WAHHTA?	4
79	126368	BOLT, 5/16-18X1.00 CARRLN	2
81	5 5 2 7 3	NUT, 5/16-18 HXWDFLLK	2
82	55023	TRIM, 77 5" BLACK NARROW	75
83	57455	SEAT, MICHIGAN GEN, W/SW HOLE	1
84	331637	1" BOLT, 500X 10HSH 5/16-18	2
85	331536-853	LEVER, QUICK ADJUST LF F4	1
86	25494	BOLT, .375X .218 HSH 5/16-18	2
87	331636	SPRING, TENSION LVR QUICK ADJ.	1

*ORDER INDIVIDUAL PARTS

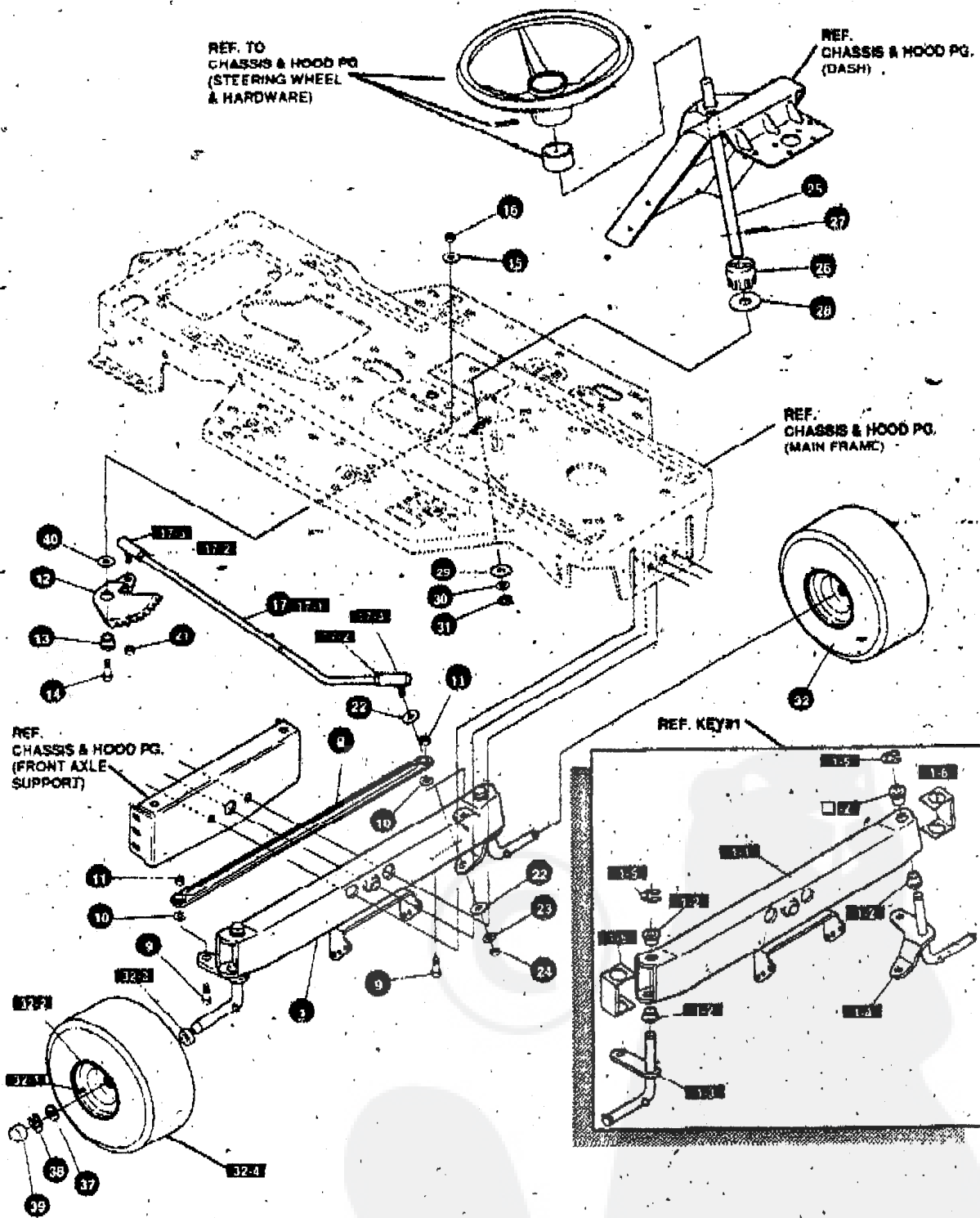

NOTE: ALWAYS USE ORIGINAL EQUIPMENT PARTS. Use of service/replacement parts other than original equipment parts may void your warranty.

ALL UNNUMBERED ITEMS ARE INTERCHANGEABLE WITH OPPOSITE SIDE

317124 I

KEY#	PART#	DESCRIPTION	QTY
	A	AXLE, FRONT ASSEMBLY LONGSUS4WSLF	1
1-1	310170-853	AXLE, FRONT	1
1-2	52407	SPINDLE BEARING	4
1-3	9180	ASSEMBLY, SPINDLE RH LG	1
1-4	314088	ASSEMBLY, SPINDLE, LH LG	1
1-5	36625	RING, RETEX .57X.05TRU5133-75	2
1-6	53373-853	AXLE COVER	1
8	304590	TIE ROD ASSEMBLY, 1.0 11LG W-SECTION	1
9	180128	SCREW, 3/8-16X1.75 HHC	2
10	120382	WASHER, REGSPTLK.393X.68X.10	2
11	489	NUT, 3/8-16 REGHXCTRLK	2
12	58289	SECTOR, STEERING LF	1
13	52406	BEARING, FL ECC.510IDX 998ODX .56	1
14	180177	SCREW, 1/2-13X1.50 HHC	1
15	22265	WASHER, FLAT .515X1.38X.116PL	1
16	1500	NUT, 1/2-13 REGHCTRLK	1
17	311100	KIT 300148 DRAGLINK	1
17-1	58291	STEERING LINK	1
17-2	124925	NUT, 3/8-24 REGHEXJAM	2
17-3	57158	BALL JOINT, 3/8 THD SHORT SYUO	1
17-4	21275	BALL JOINT, 3/8 THD LONG STUD	1
21	46692	NUT, 3/8-24 WGPLMLK WHIZ	1
22	996416	WASHER, FLAT .391X1.00X.125	2
23	120382	WASHER, REGSPTLK.393X.68X.10	1
24	120369	NUT, 3/8-24 REGHEX	1
25	58243	SHAFT, STEERING LF, 2WS	1
26	58244	PINION, STEERING LF	1
27	58274	PIN, DOWEL .2500 OD x 1.75 LG PL	1
28	301410	BEARING, FL .752IDX1.051ODX.24	1
29	301398	WASHER, FORMED 1.135X1.53X.12	1
30	21682	WASHER, FLAT .765X1.75X.042PL	1
31	36625	RING, RETEX .57X.05TRU5133-75	1
32	302828	TIRE & RIM, PU 15X6 0X6 TURWHI	2
32-1	24167	VALVE STEM	1
32-2	39829	RIM, WHEEL	1
32-3	314416	BEARING, FL	1
32-4	T I R E	REFER TO TIRE TREAD PAGE	1
37	642	WASHER, FLAT .755X1.31X.075	4
38	36825	RING, RETEX .57X.05TRU5133-75	2
39	40394	HUB CAP, 1.500 OD X 7/8 LG	2
40	49998	WASHER, FIAT .520X1.25X.209	1

ORDER INDIVIDUAL PARTS

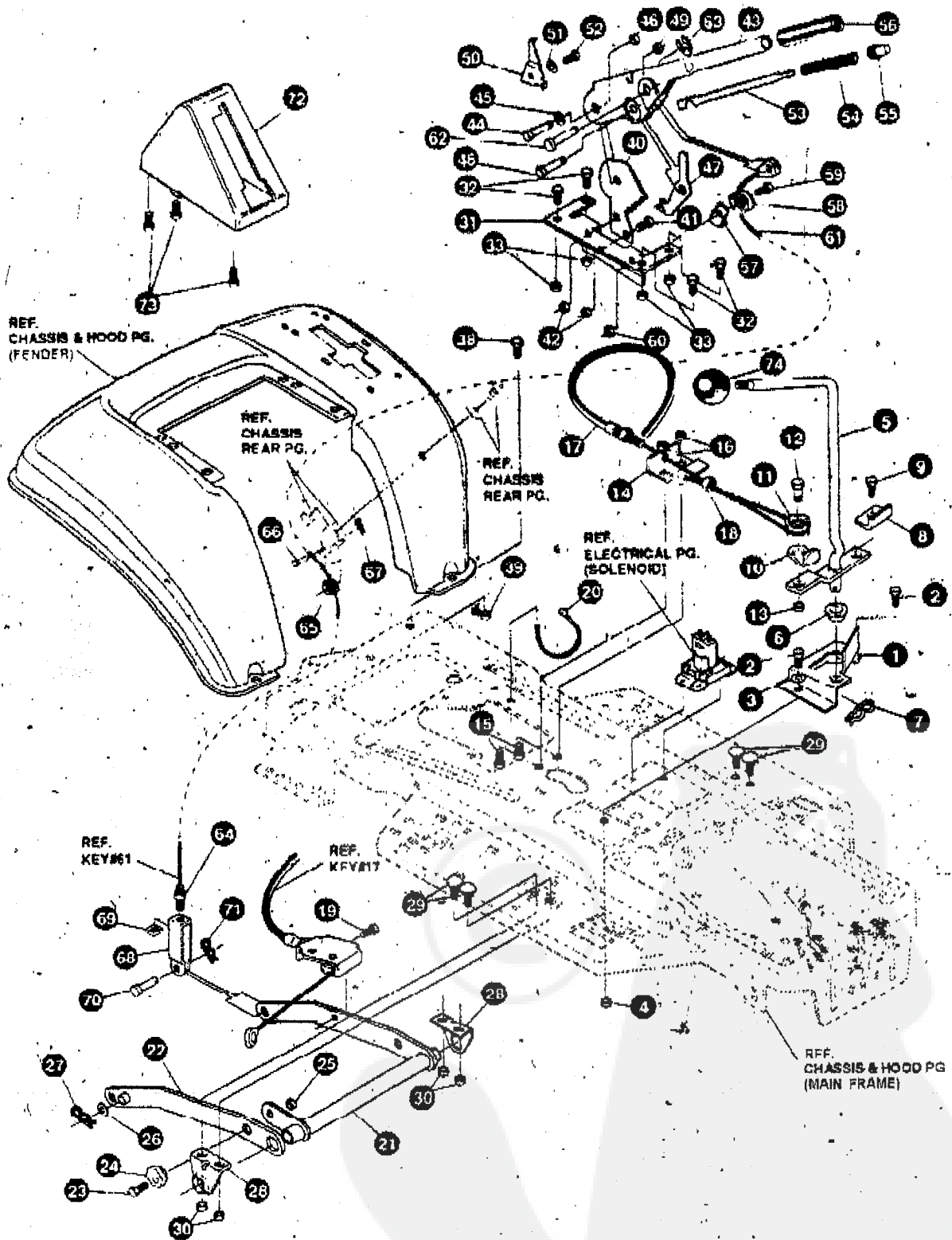

NOTE: ALWAYS USE ORIGINAL EQUIPMENT PARTS. Use of service/replacement parts other than original equipment parts may void your warranty.

ALL UNNUMBERED ITEMS ARE INTERCHANGEABLE WITH OPPOSITE SIDE

325815 D

KEY#	PART#	DESCRIPTION	QTY
1	320075-853	BRACKET, CLUTCH ENGAGE LEVER	1
2	180070	SCREW, 5/16-18X1.00 HHC	2
3	120393	WASHER, FLAT .344X .69X .065	2
4	1498	NUT, 5/16-18 REGHEXCTRLK	2
5	304701	ASSEMBLY, CLUTCH LEVER	1
6	50148	BEARING, FL 503IDX 630OX .50	1
7	8260	PIN, HAIR .091 DIA X 1.66 LG	1
8	318341	BRACKET, SWITCH ENGAGE	1
9	35488	SCREW, 5/16-18X .75 WAHTAP	1
10	1288	BRACKET, CABLE RETAIN	1
11	48306	PULLEY, POWDER METAL	1
12	58336	BOLT, .375X .375 HHS 1/4-20	1
13	1502	NUT, 1/4-20 REGHEXCTRLK	1
14	300698-853	BRACKET, FRAME CABLE	1
15	180020	SCREW, 1/4-20X .75 HHC	2
16	1502	NUT, 1/4-20 REGHEXCTRLK	2
17	301503	ASSEMBLY, CABLE, BLADE ENGAGE	1
18	120813	NUT, 1/4-28 HJAM	1
19	35498	SCREW, 5/16-18X .75 WAHTAP	1
20	57444	TIE, CABLE BLACK NYLON 5 62L	1
21	300158-853	LIFT ASSEMBLY, LH	1
22	300169-853	LIFT ASSEMBLY, RH	1
23	180079	SCREW, 5/16-18X1.00 HHC	1
24	58247	NUT, ADJUST	1
25	488	NUT, 5/16-18 REGHEXCTRLK	1
26	417096	WASHER, FLAT .501X1.06X .003	2
27	8260	PIN, HAIR .091 DIA X 1.66 LG	2
28	58248-853	BRACKET, REAR HANG SUSPENSION	2
29	57070	ROD, 5/16-18X .63 CARRLN	4
30	1498	NUT, 5/16-18 REGHEXCTRLK	4
31	318926	BRACKET, HEIGHT/ADJUST SUPPORT	1
32	110007 8	SCREW, 5/16-18X .75 HHC	4
33	1498	NUT, 5/16-18 REGHEXCTRLK	4
38	180077	SCREW, 5/16-18X .75 HHC	1
39	1498	NUT, 5/16-18 REGHEXCTRLK	1
40	301238	QUADRANT, HEIGHT ADJUST	1
41	180077	SCREW, 5/16-18X .75 HHC	2
42	1498	NUT, 5/16-18 REGHEXCTRLK	2
43	322292-853	HANDLE, LIFT SHORT(30" S.F.)	1
44	300171	BOLT, .500X .270 HHS 5/16-18	1
45	996418	WASHER, FLAT .506X .75X .024	1
46	44108	NUT, 5/16-18 HWDFLCTRLK	1
47	301239	PAWL, SQUARE	1
48	300171	BOLT, .500X .270 HHS 5/16-18	1
49	44108	NUT, 5/16-18 HWDFLCTRLK	1
50	9435	POINTER, HEIGHT ADJ	1
51	138479	WASHER, EXLK .195X .41X .03	1
52	35287	SCREW, #8-32X .38 HHWATAP	1
53	303027	ROD, ACTUATOR-SHORT	1
54	56326	SPRING, HEIGHT ADJUST	1
55	58325	KNOB, HEIGHT ADJ PUSH BUTTON	1
56	58329	GRIP, .750 OD W/ HOLE BLACK	1
57	318341 4 9	BRACKET, CABLE RETAIN	1
58	48306	PULLEY, POWDER METAL	1
59	58336	BOLT, .375X .375 HHS 1/4-20	1
60	1502	NUT, 1/4-20 REGHEXCTRLK	1
61	314177	CABLE, LIFT 22.92 F-5 20X8-8	1
62	300310	PIN, CLEVIS .310 DIA X .475 LG	1
63	300311	RING, RET E .31X .25 TRUX 5133-31	1
64	120373	NUT, 1/4-20 REGHEX	1
65	48306	PULLEY, POWDER METAL	1
66	300317	PIN, CLEVIS .375 DIA X .81 LG	1
67	8260	PIN, HAIR .091 DIA X 1.66 LG	1
68	9405	CLEVIS, LIFT CABLE	1
69	120372	NUT, 1/4-20 REGSQ	1
70	39522	PIN, CLEVIS .312 X .812	1
71	121222	PIN, COTTER .090 DIA X .75 LG	1
72	300335	LIFT COVER-39" F5	1
73	300340	SCREW, #10 X .75 HHPLAST BLK	3
74	55514	KNOB, ROUND 1.50 DIA BLACK	1

KEY#	PART#	DESCRIPTION	QTY
1	A	TRANSAXLE, FOOTE 4360-6SPHD	1
	302745	PULLEY, 6.6 OD V4L T/A	1
3	0070 9 5	KEY, HI PRO 606 .750DIA X .187WD	1
4	226 3	RING, RETEX .58X .035TRU5100-62	1
5	314120	BELT, V 4L 87.25 4WS LF	1
6	180113	SCREW, 5/16-18X3.00 HHC	4
7	120393	WASHER, FLAT .344X .69X .065	8
8	1498	NUT, 5/16-18 REGHEXCTRLK	4
9	323739	BRACKET, STABILIZER BLK	1
10	50947	SCREW, 3/8-16X1.25 WAHHTAPBLK	1
11	35498	SCREW, 5/16-18X .75 WAHHTAP	1
12	120638	WASHER, HVSPTLK .328X .60X .09	1
13	180079	SCREW, 5/16-18X1.00 HHC	1
14	120393	WASHER, FLAT .344X .69X .065	1
15	1498	NUT, 5/16-18 REGHEXCTRLK	1
16	180077	SCREW, 5/16-18X .75 HHC	1
17	138538	WASHER, REGINTLK .320X .61X .03	1
18	1498	NUT, 5/16-18 REGHEXCTRLK	1
19	319209	LEVER, SHIFT-LWR, SHIFT N GO LF	1
20	310347-853	CLIP, SHIFT LEVER .625 ROD	1
21	180077	SCREW, 5/16-18X .75 HHC	1
22	996416	WASHER, FLAT .391X1.00X .125	1
23	1498	NUT, 5/16-18 REGHEXCTRLK	1
24	310347-853	CLIP, SHIFT LEVER .625 ROD	1
25	57259	GUIDE, BELT 5/16-18THD	1
26	996416	WASHER, FLAT .391X1.00X .125	1
27	1498	NUT, 5/16-18 REGHEXCTRLK	1
28	320383	UPPER SHIFT LEVER ASSEMBLY	1
29	321092	BOLT, .380X .500 HSH 1/4-20	1
30	50352	NUT, 1/4-20 WDFLLK TOPLOCK	1
31	120377	NUT, 3/8-16 REGHX	1
32	306689	HANDLE, 3/8-16 MOLDED BLACK 853	1
33	137185	PIN, COTTER .125 DIA X 1.00 LG	1
34	316557	LINK TIE ROD SHIFT 7 477C/L	1
35	180124	SCREW, 3/8-16X1.25 HHC	1
3 6	120382	WASHER, REGSPTLK .393X .68X .10	1
37	1498	NUT, 3/8-16 REGHXCTRLK	1
38	309637	BRACKET, SHIFT 5SP SF	1
39	180124	SCREW, 3/8-16X1.25 HHC	1
40	120394	WASHER, FLAT .406X .81X .065	2
41	1498	NUT, 3/8-16 REGHXCTRLK	1
42	5 7 1 5 7	WASHER, .750X .250 SP-TRANSAXLE	1
43	56255	SCREW, 1/4-28X .75 NYLHHC	1
44	319506-853	QUADRANT, SHIFT, FOOTE F4360 6HD	1
45	305650	SCREW, 1/4-20X .50 PHPNTAP	1
46	1502	NUT, 1/4-20 REGHEXCTRLK	4
47	321517	BRACKET, FRAME SHIFT	1
48	180022	SCREW, 1/4-20X1.00 HHC	1
49	57038	BOLT, 1/4-20X .63 CARRLN	1
50	120392	WASHER, FLAT .281X .63X .065	1
51	316060	SPACER, 3/28 X .50 X .38	1
52	1502	NUT, 1/4-20 REGHEXCTRLK	2
5 3	3 1 9 8 0 3	CABLE, SHIFT N GO	1
5 4	57444	TIE, CABLE BLACK NYLON 5 62L	1
55	314837	SPRING, MEMORY	1

* CONTACT YOUR NEAREST TRANSAXLE DEALER FOR PARTS & SERVICE

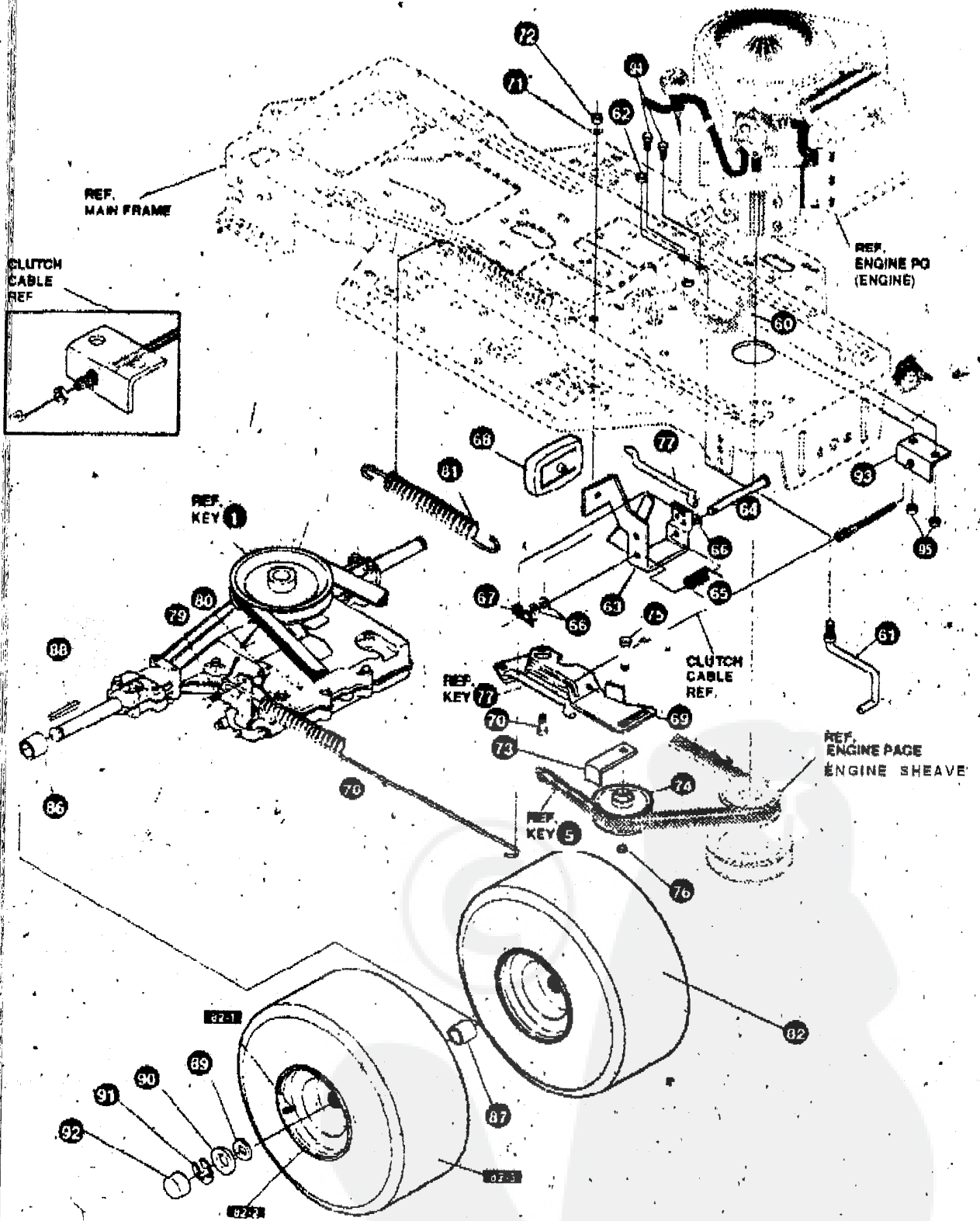

NOTE: ALWAYS USE ORIGINAL EQUIPMENT PARTS. Use of service/replacement parts other than original equipment parts may void your warranty.

ALL UNNUMBERED ITEMS ARE INTERCHANGEABLE WITH OPPOSITE SIDE

327752 C

KEY#	PART#	DESCRIPTION	QTY
60	321514	SPRING, DRAG LINK BIAS	1
61	304018	GUIDE, BELT R.H.	1
62	1498	NUT, 5/16-18 REGHEXCTRLK	1
63	525942	PEDAL ASSEMBLY, BRAKE/CLUTCH LF	1
64	319675	PIN, CLEVIS 500DX4.53LG	1
65	57847	SPRING, BRAKE PEDAL	1
66	2968	WASHER, FLAT .504X .75X .059	1
67	56180	PIN, HAIR .091 DIA X 1.62LG	1
68	48100	PAD, CLUTCH BRAKE W/PINING	1
69	320381	ARM, IDLER TRACTION, SOG LF	1
70	329980	BOLT, .625X .135 HSSH 5/16-18	1
71	4 5 6 0 2	WASHER, FLAT .333X .87X .119	1
72	1 4 9 8	NUT, 5/16-18 REGHEXCTRLK	1
73	39859	RETAINER, BELT	1
74	35374	PULLEY, IDLER V4L 3.08X .82	1
75	45892	BOLT, 3/8-16X1.50 CARRIEN	1
76	1499	NUT, 3/8-16 REGHEXCTRLK	1
77	57204	ROD, CLUTCH 3.92	1
78	226937	SPRING, BRAKE 28 80 930.4360	1
79	328131	BOLT, .495X .31 HSSH 5/16-18	1
80	1498	NUT, 5/16-18 REGHEXCTRLK	1
81	322809	SPRING, CLUTCH	1
82	301318	TIRE & RIM, 20X10 00-8	1
82-1	24167	VALVE STEM	1
82-2	301365	RIM, WHEEL	1
82-3	TIRE	REFER TO TIRE TREAD PAGE	1
86	57479	SPACER, SLEV .75 X1 25X1 .92	2
87	301565	SPACER, SLEV .750X1 25X .50 PL	2
88	52928	KEY, SQUARE 187SQX2.25LG	2
89	642	WASHER, FLAT .755X1.31X .075	4
90	42815	WASHER, FLAT .755X1.53X .07	2
91	36625	RING, RETEX .57X .05TRU5133-75	2
92	40394	HUB CAP, 1300ID X 7/8LG	2
93	3 2 1 5 1 7	BRACKET, FRAME SHIFT	1
94	180020	SCREW, 1/4-20X .75 HHC	1
95	1502	NUT, 1/4-20 REGHEXCTRLK	2

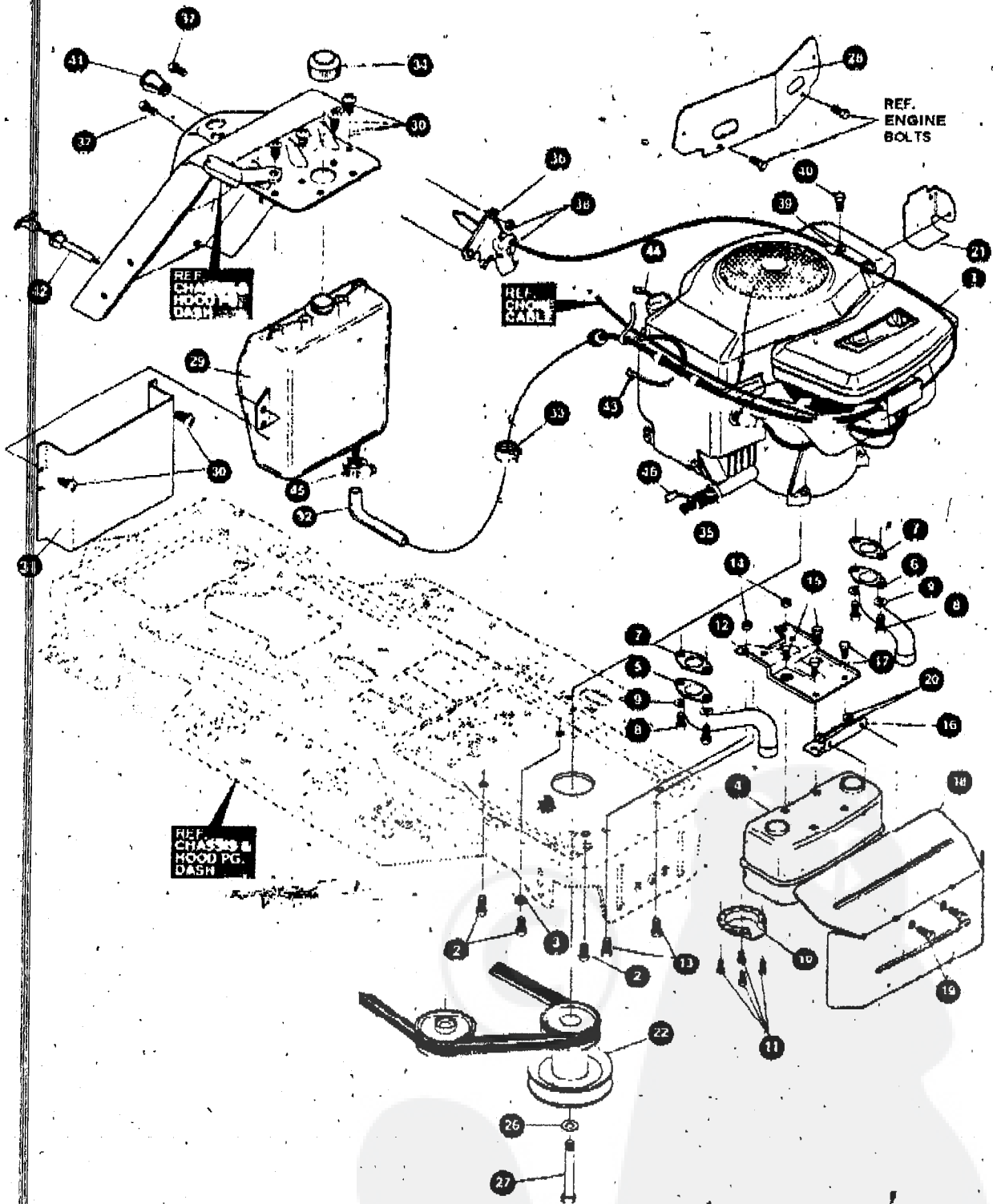

NOTE: ALWAYS USE ORIGINAL EQUIPMENT PARTS. Use of service/replacement parts other than original equipment parts may void your warranty.

ALL UNNUMBERED ITEMS ARE INTERCHANGEABLE WITH OPPOSITE SIDE

326270 B

KEY#	PART#	DESCRIPTION	QTY
1	A	14-18STD/IC DUAL CIR	1
2	50947	SCREW, 3/8-16X1.25 WAHHTAPBLKP	4
3	138489	WASHER, EXLK .384X.69X.04	1
4	305650	MUFFLER, 18/18HP LARGE LO-TONE	1
5	305652	EXHAUST TUBE, 18" BBS RH	1
6	3 0 5 5 5 1	EXHAUST TUBE, 18HP LH	1
7	66640	GASKET, MUFFLER	2
8	180020	SCREW, 1/4-20X.75 HMC	4
9	120380	WASHER, REGSPTLK 263X.49X.07	4
10	5 6 4 7 2	DEFLECTOR SIDE OUT (68222573)	1
11	35287	SCREW, #8-32X.38 HHWATAP	4
12	304709-853	BRACKET, MUFFLER	2
13	58030	SCREW, 5/16-18X.75WDFLLK	1
14	5 5 2 7 3	NUT, 5/16-18 1XWDFLLK	2
15	995346	SCREW, 1/4-20X.50 WAHHTAP	2
16	9796	BRACKET, TRANSAXLE	1
17	44811	SCREW, 1/4-20X.75 WAHHTAP	2
18	327937	HEAT SHIELD, 14-18HP TWIN OP	1
19	180077	SCREW, 5/16-18X.75 HMC	2
20	55273	NUT, 5/16-18 HXWDFLLK	2
21	56470-853	DEFLECTOR, COOL AIR	1
22	328029	PULLEY, ENGINE 4 40OFF/5 00D/3 00D	1
26	120383	WASHER, REGSPTLK.459X.78X.12	1
27	429644	SCREW, 7/16-20X.50 HHC	1
28	3 0 5 3 8 5 8 5 3	BULKHEAD, HOOD H-15	1
29	314992	TANK, FUEL 2 GAL CLEAR	1
30	49060	SCREW, 1/4-10X.75PHPTAP	6
31	301087-853	SHIELD, HEAT GAS TANK	1
32	41007	TUBING, .25X.50X BULK GAS LINE	15.5'
33	47345	CLAMP, HOSE SCREWTYPE	1
34	46704	CAP, GAS 1 1/2-7 THD BLK	1
35	325547	OIL DRAIN VALVE ASSEMBLY	1
36	300456	CONTROL, THROTTLE 31 LG TWIN BS	1
37	320653	SCREW, 10-24X.38PHPNMA CRSS	2
38	308459	NUT, #10-24HXHDNYLK	2
39	56538	RETAINER, WIRE	1
40	35258	SCREW, 10-24X.38 SLHWATAP	1
41	50607	KNOB, ROUND THROTTLE BLACK	1
42	3 0 0 4 3 2	CONTROL, CHOKE 47.13 LG FAN TK	1
43	67444	TIE, CABLE BLACK NYLON 5.62L	2
45	47345	CLAMP, HOSE SCREW TYPE	1
46	327422	CAP, OIL DRAIN VALVE ASM YEUOW	1

* SEE ENGINE MANUAL

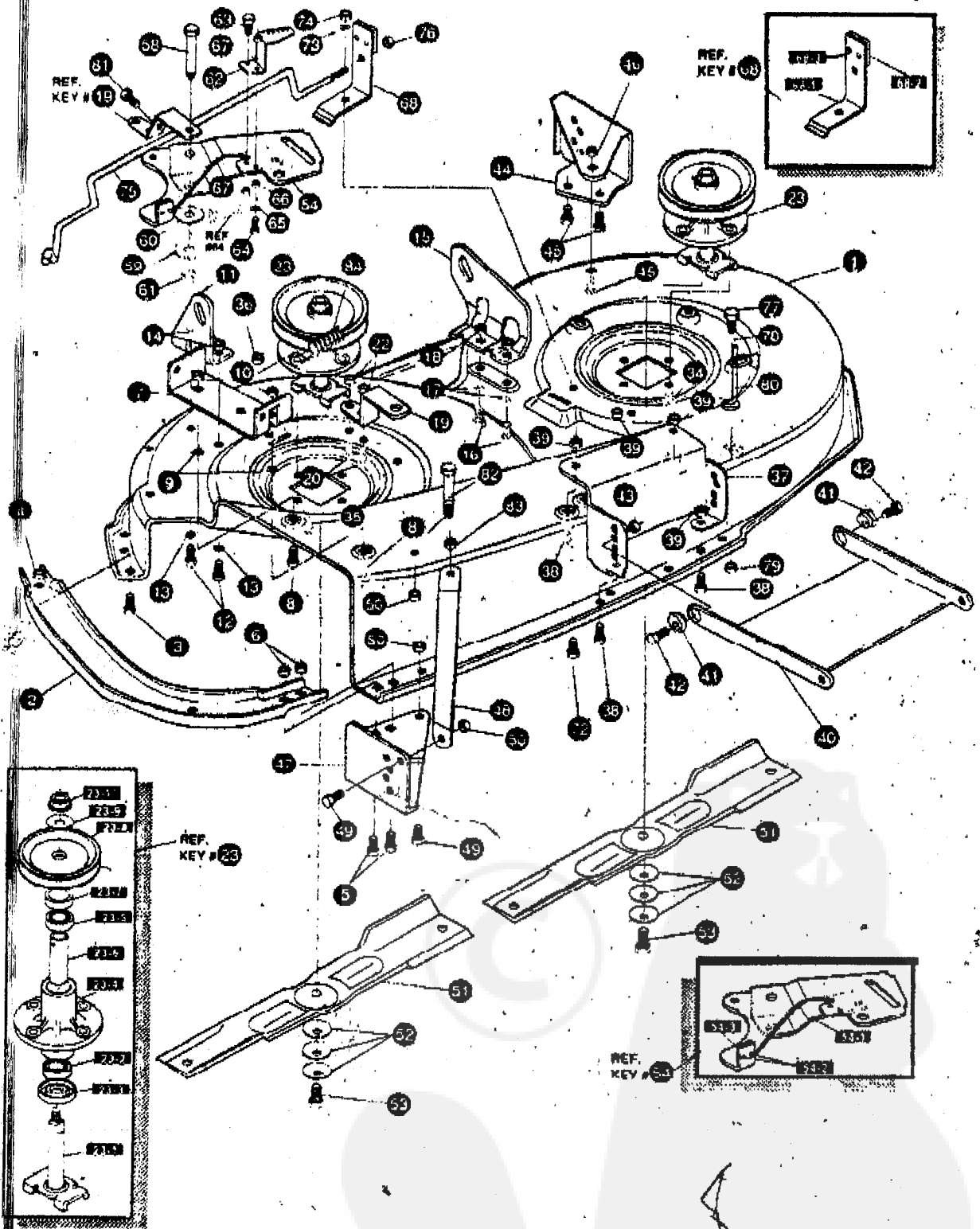

NOTE: ALWAYS USE ORIGINAL EQUIPMENT PARTS. Use of service/replacement parts other than original equipment parts may void your warranty.

ALL UNNUMBERED ITEMS ARE INTERCHANGEABLE WITH OPPOSITE SIDE

324144 G

KEY#	PART#	DESCRIPTION	QTY
1	325116	43" DECK KIT	1
2	325480-853	TOE GUARD - MULCHER	1
3	180077	SCREW, 5/16-18X.75 HHC	1
4	1498	NUT, 5/16-18 REGHEXCTRLK	1
5	180077	SCREW, 5/16-18X.75 HHC	2
6	1498	NUT, 5/16-18 REGHEXCTRLK	2
7	317017	BRACKET, CHUTE MOUNT BLACK	1
8	180077	SCREW, 5/16-18X.75 HHC	1
9	120393	WASHER, FLAT .344X.69X.065	2
10	1498	NUT, 5/16-18 REGHEXCTRLK	2
11	313929	LIFT BRACKET, REAR RH BLK 853	1
12	180077	SCREW, 5/16-18X.75 HHC	2
13	120393	WASHER, FLAT .344X.69X.065	2
14	1498	NUT, 5/16-18 REGHEXCTRLK	2
15	310667	BRACKET, DECK LIFT REAR LHBLK	2
16	180077	SCREW, 5/16-18X.75 HHC	2
17	120393	WASHER, FLAT .344X.69X.065	2
18	1498	NUT, 5/16-18 REGHEXCTRLK	2
19	325893	BRACE, IDLER SUPPORT 40", 43"	2
20	180077	SCREW, 5/16-18X.75 HHC	2
22	4 4 1 0 0	NUT, 5/16-18 HWDFLCTRLK	2
23	56424	QUILL ASSEMBLY, 36/39/40/43	2
23-1	56425	SHAFT/SADDLE 36"	1
23-2	49562	BEARING, BALL 6203-2AA(SEALS)-C3	1
23-3	50616	DUST SHIELD	1
23-4	5 5 5 4 7	QUILL CASTING 1046	1
23-5	49562	BEARING, BALLS 2032AA(SEALS)-C3	1
23-6	50810	SPACER, SLEEVE .669X.88X3.797	1
23-7	51449	SPACER, SLEEVE .672X.93X.436PM	1
23-8	313898	PULLEY ASSEMBLY	1
23-9	56365	WASHER, SPECIAL QUILL	1
23-10	1282	NUT, 7/16-20 WDFLLK	1
34	35498	SCREW, 5/16-18X.75 WAHHTAP	1
35	300345	SCREW, 5/16-18X1.38 WAHHTAP	1
36	1498	NUT, 5/16-18 REGHEXCTRLK	1
37	317040	BRACKET FRONT BLACK	1
38	180077	SCREW, 5/16-18X.75 HHC	4
39	1498	NUT, 5/16-18 REGHEXCTRLK	4
40	56305	BRACKET, LINK DECK FRONT	1
41	56247	NUT, ADJUST	2
42	180078	SCREW, 5/16-18X1.00 HHC	2
43	1498	NUT, 5/16-18 REGHEXCTRLK	1
44	317041	BRACKET, GAGE WHEEL LH BLACK	1
45	180077	SCREW, 5/16-18X.75 HHC	3
46	1498	NUT, 5/16-18 REGHEXCTRLK	3
47	322464	BRACKET, GAGE WHEEL A H. FRONT	1
48	314282	BRACKET, STABILIZER	1
49	180077	SCREW, 5/16-18X.75 HHC	2
50	1498	NUT, 5/16-18 REGHEXCTRLK	3
51	325963	BLADE, 43" BLK	2
52	2463	WASHER, 39IDX1.25DX.07 BELLVIL	6
53	39573	SCREW, 3/8-24X1.00 NYLHHC	2
54	320576	IDLER ARM ASSEMBLY	1
54-1	322116	ARM IDLER, 40/43 DECK	1
54-2	41601	RIVET, OVSET 187DIA X .50LG ST	2
54-3	306973	BRAKE PAD - HARD - 232AF	1
58	304420	BOLT, 500X2.15 HSSH	1
59	995416	WASHER, FLAT .391X1.00X.125	1
60	006307	WASHER, FLAT .391X1.00X.209	1
61	45171	NUT, 3/8-16 HWDFL WHIZ-LOCK	1
62	326249	BRACKET, EXTENSION IDLER	1
63	180077	SCREW, 5/16-18X.75 HHC	1
64	180063	SCREW, 5/16-18X1.50 HHC	1
65	446363	WASHER, FLAT .375X.68X.082	1
66	271184	NUT, 5/16-18 HEXKEPS	1
67	1498	NUT, 5/16-18 REGHEXCTRLK	2
68	321828	BLADE BRAKE ASSEMBLY	1
68-1	135624	RIVET, TRSET, 185DIA X 41LG ST	2
68-2	304119	BRAKE ARM	1
68-3	306973	BRAKE PAD - HARD - 232AF	1
72	180077	SCREW, 5/16-18X.75 HHC	1
73	120393	WASHER, FLAT .344X.69X.065	1
74	1498	NUT, 5/16-18 REGHEXCTRLK	1
75	314079	ROD, BRAKE	1
76	1502	NUT, 1/4-20 REGHEXCTRLK	1
77	180079	SCREW, 5/16-18X1.00 HHC	1
78	120393	WASHER, FLAT .344X.69X.065	1
79	1498	NUT, 5/16-18 REGHEXCTRLK	1
80	325965	BELT GUIDE, 43" DECK UPSTOP	1
81	308231	SCREW, 1/4-20X1.25 HHWTAP	1
82	311104	SCREW, 5/16-18X1.00 HHC	1
83	271184	NUT, 5/16-18 HEXKEPS	1
84	35410	SPRING, .071 X .62 X 4.37	1

E3583-080

REPAIR PARTS

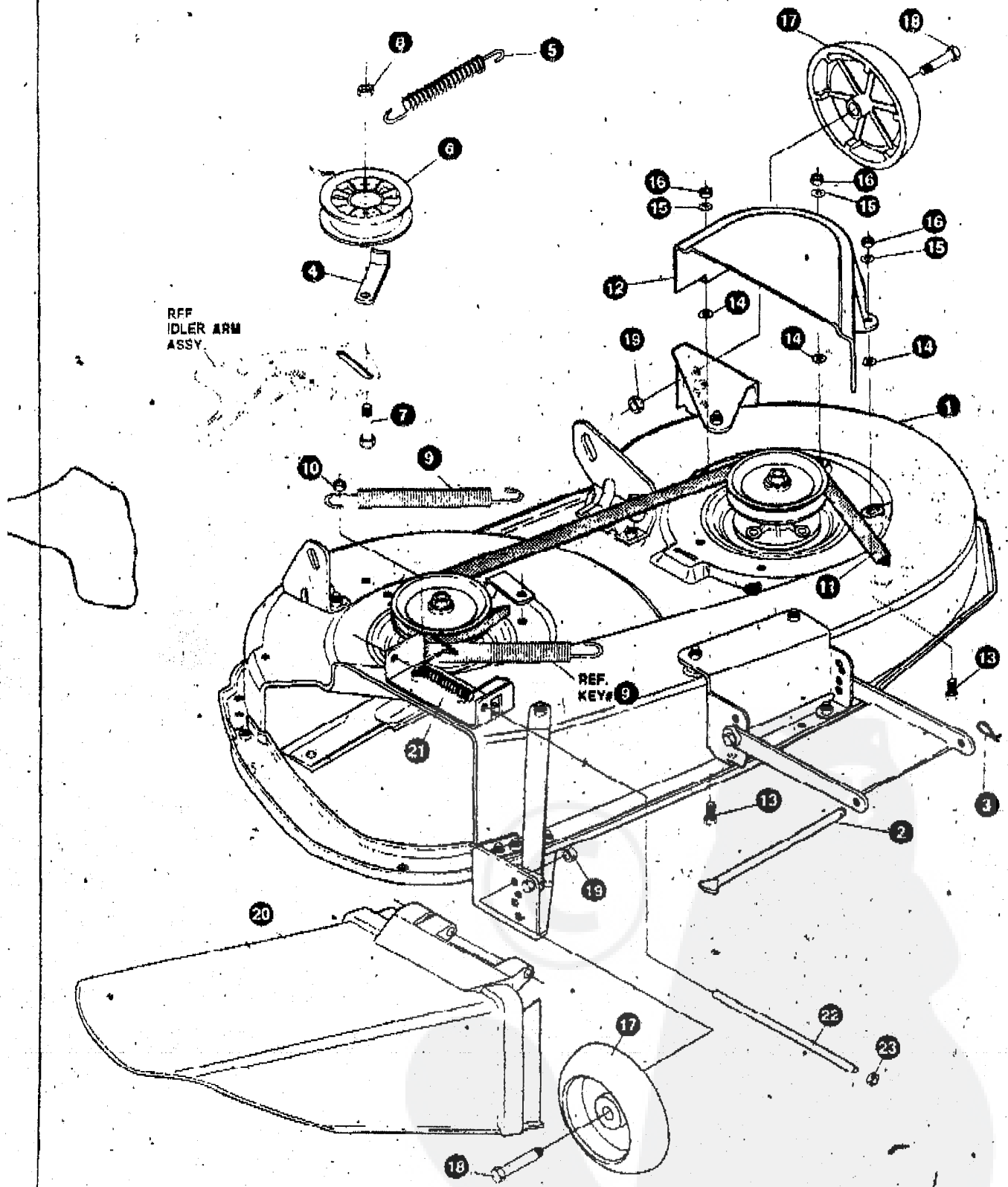

NOTE: ALWAYS USE ORIGINAL EQUIPMENT PARTS Use of service/replacement parts other than original equipment parts may void your warranty.

ALL UNNUMBERED ITEMS ARE INTERCHANGEABLE WITH OPPOSITE SIDE

326401 c

KEY#	PART#	DESCRIPTION	QTY
1			
2	329036	DECK, 43" MOWER 2-WH EXPORT	1
3	58306	ROD, DECK HITCH	1
4	8260	PIN, HAIR .091 DIA X 1.66 LG	1
	1346	RETAINER, BELT	1
5	314107	SPRING, TENSION 5.00 LG + 17 LB IN	1
6	310328	PULLEY, IDLER BFF 4.00 WIDE FL	1
7	126416	BOLT, 3/8-16 X 1.75 CARRLN	1
8	45171	NUT, 3/8-16 HWD FL WHIZ-LOCK	1
9	35410	SPRING, .071 X .62 X 4.37	1
10	1498	NUT, 5/16-18 REG HEX CTRLK	1
11	314108	BELT, V 5L 86 00 KEVLAR	1
12	333073	GUARD, BELT LH PLASTIC	1
13	57101	BOLT, 5/16-18 X .75 CARRSN	3
14	309438	PUSHNUT, 5/16 BOLT RETAINER	3
15	120393	WASHER, FIAT. 344X .69 X .065	3
16	1408	NUT, 5/16-18 REG HEX CTRLK	3
17	302811	GAUGE WHEEL, EURO 6.00 OD X 1.38 WD	2
18	23763	BOLT, .500 X 1.390 HHSH 3/8-16	2
19	1499	NUT, 3/8-16 REG HEX CTRLK	2
20	304422	CHUTE DEFLECTOR, 40" X 42" X 43"	1
21	314975	SPRING, TORSION CHUTE DEFLECTOR	1
22	304424	ROD, PIVOT DECK 3120 X 7.25	1
23	3535	NUT, PUSH ON CAP .312 OD	1

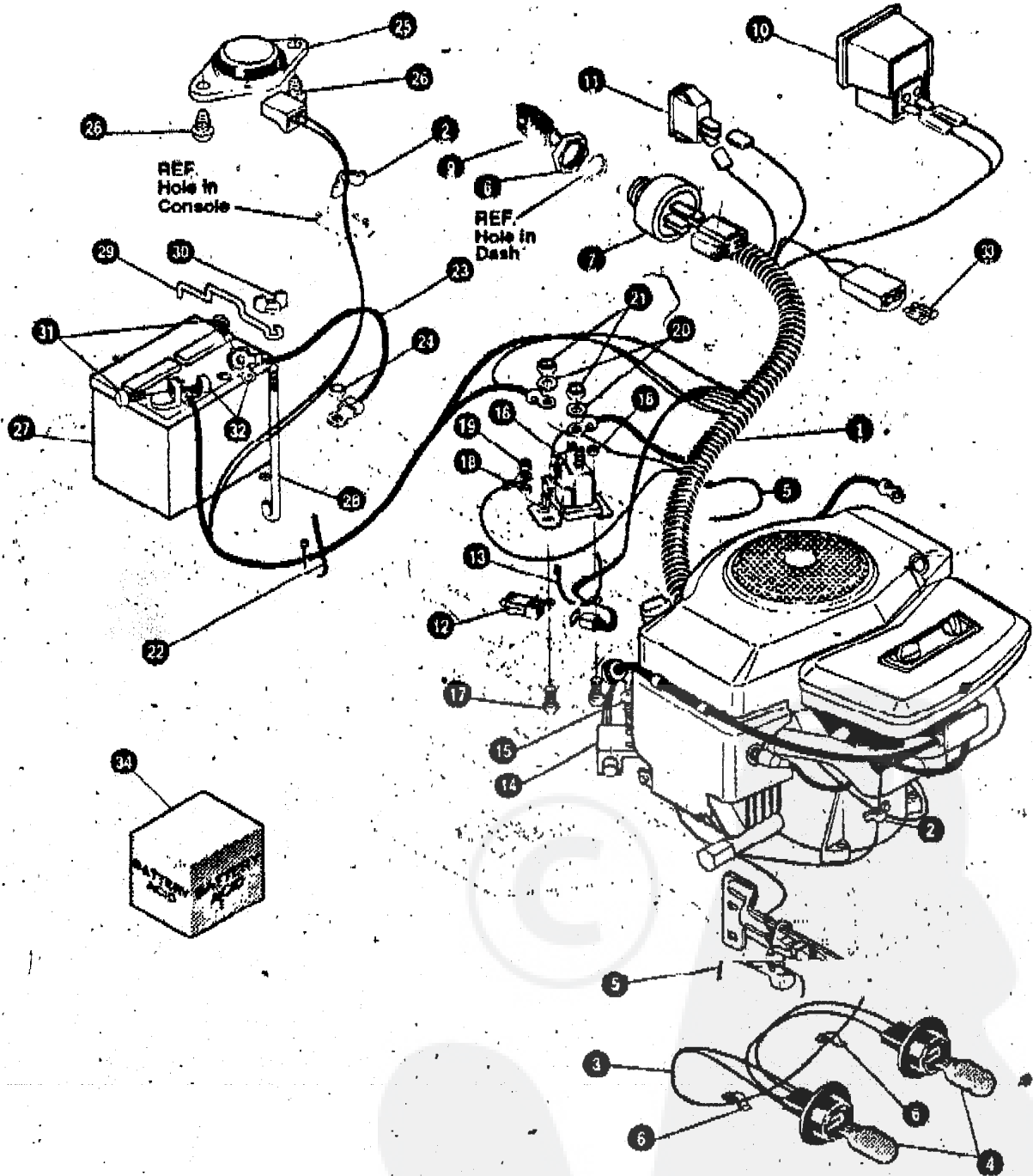

NOTE: ALWAYS USE ORIGINAL EQUIPMENT PARTS. Use of service/replacement parts other than original equipment parts may void your warranty.

ALL UNNUMBERED ITEMS ARE INTERCHANGEABLE WITH OPPOSITE SIDE

325513 C

KEY#	PART#	DESCRIPTION	QTY'
1	322793	WIRE HARNESS, 14-18TWIN OPP DYN	1
2	41482	PRESS CLIP, 1.380LG .255ID	2
3	303064	ASSEMBLY, LIGHT WIRE-1/4 TURN	1
4	52572	BULB, HEADLAMP	2
5	57444	TIE, CARIF BLACK NYLON 5 62L	2
6	41482	PRESS CLIP, 1.380LG .255ID	2
	327355	SWITCH-IGNITION (AFTER FIRE) 3 POSITION	1
	327352	NUT, 5/8-8ACME DELTA FOR BOOT	1
9	3 2 7 3 5 B	KEY, IGNITION DELTA	2
10	300133	AMMETER	1
1 1	300334	*LIGHT SWITCH, ON/OFF PANEL MNT	1
	320002	*SWITCH, DOUBLE POLE NO/NC GRAY	1
13	57444	TIE, CABLE BLACK NYLON 5 62L	1
14	57476	*SWITCH, SCREW MNT DP NC NO BLK	1
15	57220	*SCREW, XIZ X 50 PHPNHTAP BLK	2
16	53716	SOLENOID	1
17	187745	SCREW, 1/4-20X .75 HXSEMMA	2
16	1502	NUT, 1/4-20 REGHEXCTRLK	2
19	271172	NUT, 1/4-20 REGHEXKEPS	1
20	138485	WASHER, EXLK .320X.61X.03	2
2 1	120368	NUT, 5/16-24 REGHEX	2
22	57444	TIE, CABLE BLACK NYLON 5 62L	1
23	55511	WIRE, GROUND, 12.5"	1
24	271184	NUT, 5/16-1 8 HEXKEPS	1
25	57547	SWITCH, SEAT	1
26	160505	SCREW, 1/4-20X .38PHPNHMA	2
27	302257	BATTERY, 12V	1
28	57551	ROD, BATTERY	1
29	57552	ROD, BATTERY, TOP	1
30	325232	NUT, WING 1/4-20NYLON	1
31	180020	*SCREW, 1/4-20X .75 HHC	2
32	271172	NUT, 1/4-20 REGHEXKEPS	2
34		BATTERY ACID PACK, 90 OZ	1

* CAN BE PURCHASED LOCALLY

WIRING SCHEMATIC

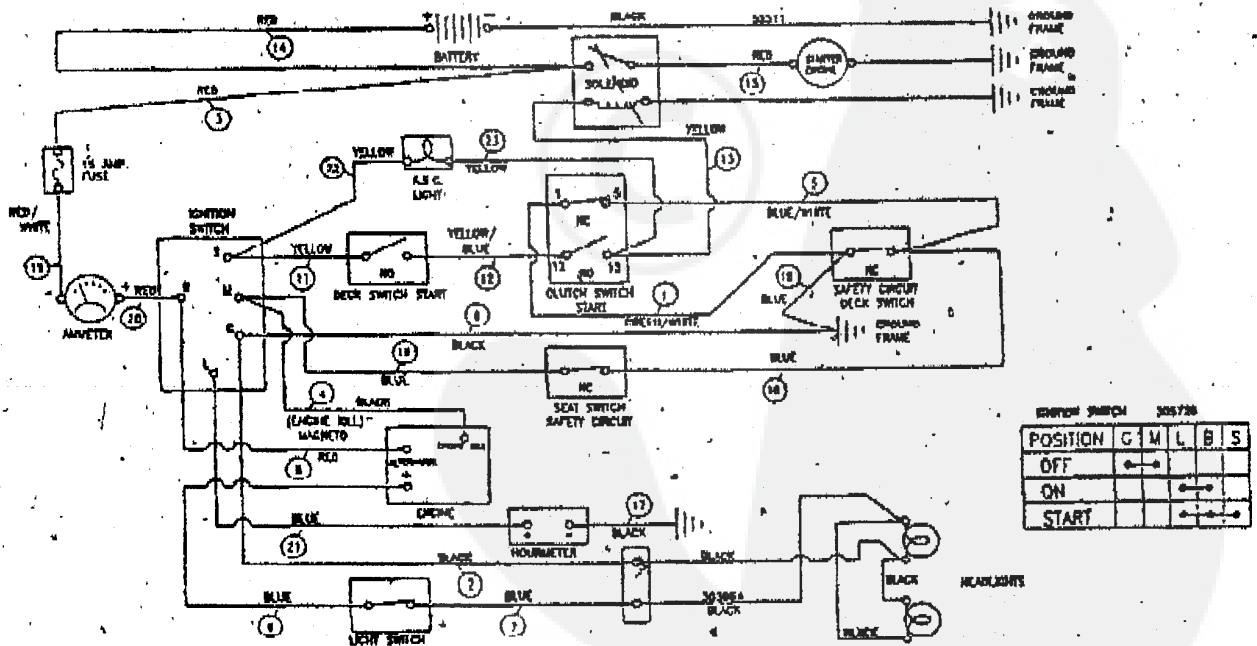

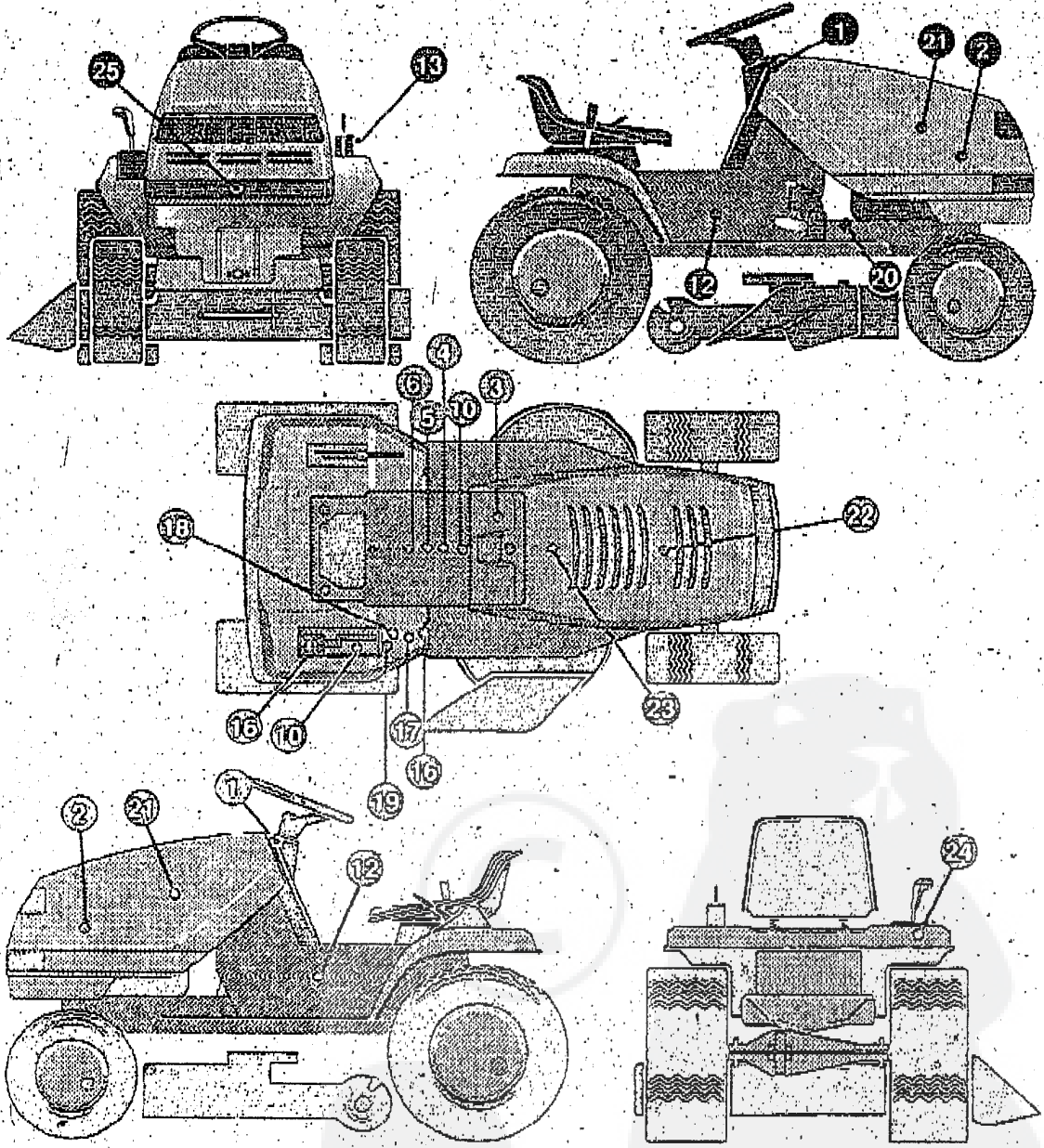

KEY#	PART#	DESCRIPTION	QTY
1	313208	DECAL, DASHWEAR STRIP RED	2
2	304007	NAME PLATE, LG DYNAMARK WHITE	2
3	324534	DECAL, LF DASH LSW/CHOK EXP	1
4	307363	DECAL, INSTRUCT CONSOLE TOP ENG	1
5	69525	DECAL, INSTRUCT CONSOLE TOP FR	1
6	69524	DECAL, INSTRUCT CONSOLE TOP GER	1
10	311064	DECAL, INSTRUCT, CONSOLE TOP SPA	1
12	316370	DECAL, 18/43 PLASTIC PLATE	2
13	402214	DECAL, HEIGHT ADJUST	1
15	322169	DECAL, FENDER 6 SPEED SOG	1
16	305770	DECAL, CAUTION TRIANGLE EUROPE	1
17	68902	DECAL, WARNING, FRENCH/GERMAN	1
18	310553	DECAL, DANGER ENGLISH	1
19	311069	DECAL, DANGER SPANISH	1
20	66903	DECAL, BRAKE/CLUTCH ISO	1
21	305603	PAD, 18 X 6 FOAM HOOD	2
22	307277	PAD, 12 X 4 FOAM HOOD	1
23	307276	PAD, 15 X 7 FOAM HOOD	1
24	402158	NAMEPLATE, SHIFT ON THE GO	1
25	319986	DECAL, TAPE H15 8MIL VINYL	1

TREAD PATTERNS

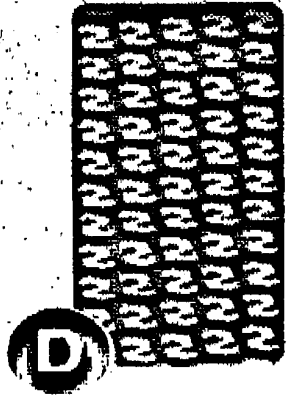
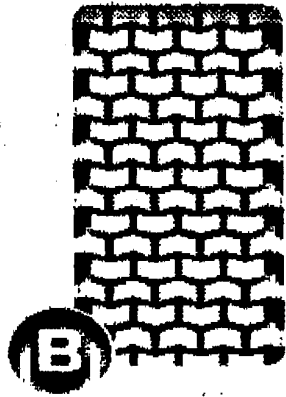
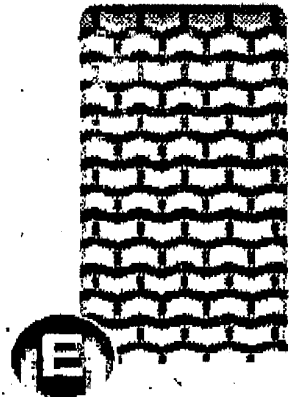
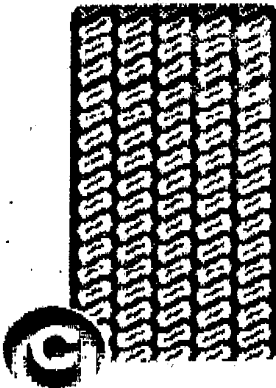

TIRE SEE	"A"	"B"	"C"	"D"	"E"
11x4.00-5	42295	319679			
13x5.00-6	41060	319680			
15 X 6.00 - 6	39830	316702	301140	313952	
16 X 4.80 - 8	41081	309088		314539	
16 X 6.50 - 8					
18x6.50-8		42091			
18x8.50-8					
18x9.50-8	319683	317400		313950	
20x8.00-8	319685	319684	57164	814584	331606
20 X 10.00 - 8	58276	319686		313654	
20x10.00-10	55893	319687			
23 X 9.50 - 12	53655	319690	319689	314370	

Contact the dealer where your tractor was purchased for the available accessories. If you are unable to contact the dealer, write to the address on the front cover of this manual.

Large Lawn Tractor

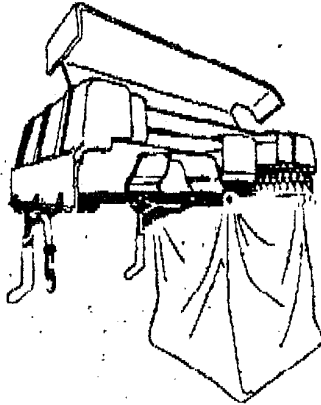

Model # 5708-34
Grass Collector for
40, 42, 43" decks

For heavy duty grass
collection order Model
#5709-10 AC Assist

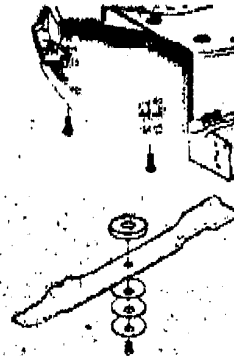

5717-00
Mulching Kit (42/43" Deck)
5716-00
Mulching Kit (40" deck)

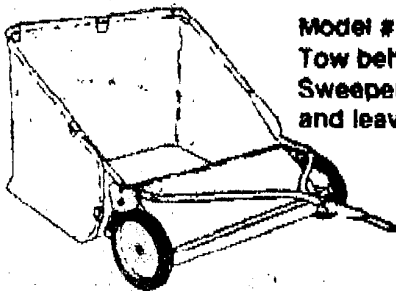

Model # 5648-16
Tow behind Lawn
Sweeper for grass
and leaves

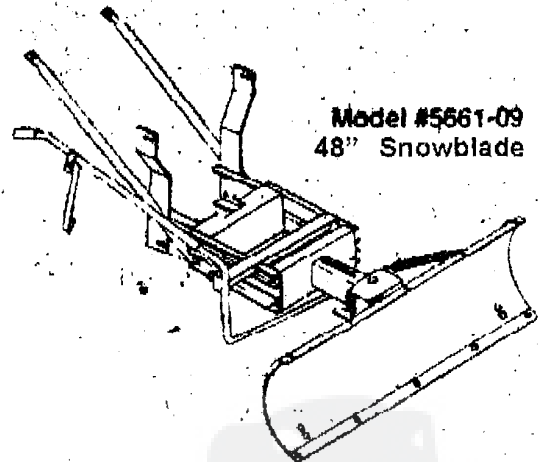

Model #5661-09
48" Snowblade

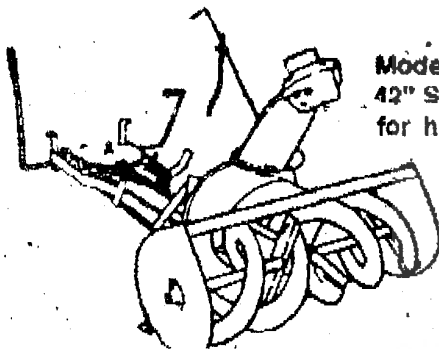

Model #5705-06
42" Snowthrower
for heavy snowfall



Model # 5585-00
Tire Chains - 20" x 8.0" tires
Model # 5706-00
Tire Chains - 20" x 10.0" tires

OTHER ACCESSORIES

Model	Description
5672-01	Wheel Weights - Front - 1 pr. w/mtg. hdw. - Fits 15" tires
5673-02	Wheel Weights - Rear - 1 pr. w/mtg. hdw. - Fits 18" & 20" tires
316608	43" High Lift Blade for Bagging or Side Discharge (Requires 2)
325762	43" Mulching Blade (Requires 2)