

PARTS MANUAL

Lawn Tractors

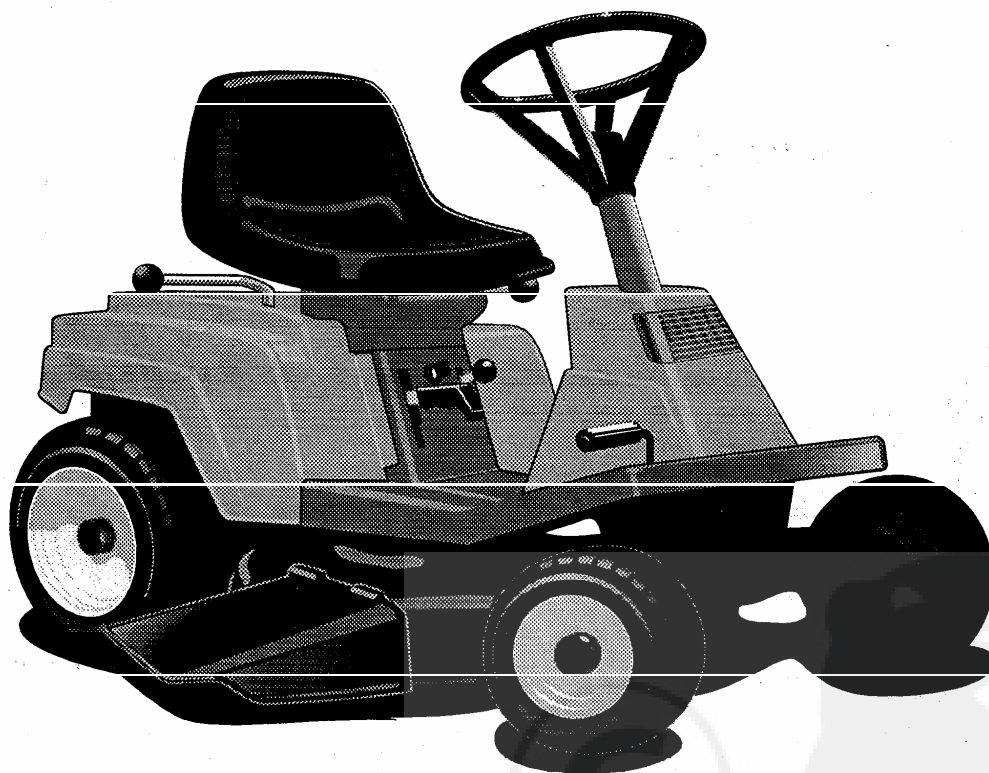

Model E3595-080

SAFETY RULES

THESE INSTRUCTIONS ARE FOR YOUR PROTECTION. PLEASE READ THEM CAREFULLY.

IMPORTANT

THIS CUTTING MACHINE IS CAPABLE OF AMPUTATING HANDS AND FEET AND THROWING OBJECTS. FAILURE TO OBSERVE THE FOLLOWING SAFETY INSTRUCTIONS COULD RESULT IN SERIOUS INJURY OR DEATH.

I. GENERAL OPERATION:

- Know controls and how to stop quickly.
- Read, understand, and follow all instructions in the manual and on the machine before starting.
- Only allow responsible adults, who are familiar with instructions, to operate the machine.
- Wear safety glasses or eye shields when assembling or operating the machine.
- Do not operate machine when barefooted. Always wear substantial footwear, preferably steel-toed shoes.
- Do not wear loose fitting clothing that could get caught in moving parts.
- Clear the area of objects such as rocks, toys, wire, etc., which could be picked up and thrown by the blade(s).
Be sure the area is clear of other people before mowing. Stop machine if anyone enters the area.
- Never carry passengers.
- Do not mow in reverse unless absolutely necessary. Always look down and behind before and while backing.
- Be aware of the mower discharge direction and do not point it at anyone. Do not operate the mower without either the entire grass catcher or the guard in place.
- Slow down before turning.
- Never leave a running machine unattended. Always turn off blades, set parking brake, stop engine, and remove keys before dismounting.
- Turn off blade(s) when not mowing.
- Stop engine before removing grass catcher or unclogging chute.
- Mow only in daylight or good artificial light.
- Do not operate the machine while under the influence of alcohol or drugs.
- Watch for traffic when operating near or crossing roadways.
- Use care when mowing around a fixed object to prevent the blade(s) from striking it. Never deliberately run over any foreign object.
- Use extra care when loading or unloading the machine into a trailer or truck.
- Use care when pulling loads or using heavy equipment.
 - a. Use only approved drawbar hitch points.
 - b. Limit loads to those that you can safely control.
 - c. Do not turn sharply. Use care when backing.
 - d. Use counterweight(s), wheel weight or tire chains when suggested in attachment(s) instructions.

II. SLOPE OPERATION:

Slopes are a major factor related to loss-of-control and tip-over accidents, which can result in severe injury or death. *All slopes require extra caution.* If you cannot back up the slope or if you feel uneasy on it, do not mow it.

DO

- Mow up and down slopes, not across.
- Remove obstacles such as rocks, tree limbs, etc.
- Watch for holes, ruts, or bumps. Uneven terrain could overturn the machine. *Tall grass can hide obstacles.*
- Use slow speed. Choose a low gear so that you will not have to stop or shift while on the slope.
- Follow the manufacturer's recommendations for wheel weights or counterweights to improve stability.
- Use extra care with grass catchers or other attachments. These can change the stability of the machine.
- Keep all movement on the slopes *slow and gradual*. Do not make sudden changes in speed or direction.
- Avoid starting or stopping on a slope. If tires lose traction, turn off the blade(s) and proceed slowly *straight* down the slope.

DO NOT

- Do not turn on slopes unless necessary, and then slowly and gradually downhill, if possible.
- Do not mow near drop-offs, ditches or embankments. The

mower could suddenly turn over if a wheel is over the edge of a cliff or ditch, or if an edge caves in.

- Do not mow on wet grass. Reduced traction could cause sliding.
- Do not try to stabilize the machine by putting your foot on the ground.
- Do not use grass catcher on steep slopes.

III. CHILDREN:

Tragic accidents can occur if the operator is not alert to the presence of children. Children are often attracted to the machine and the mowing activity. *Never* assume that children will remain where you last saw them.

- Keep children out of the mowing area and under the watchful care of another responsible adult.
- Be alert and turn machine off if children enter the area.
- Before and when backing, look behind and *down* for small children.
- Never carry children. They may fall off and be seriously injured or interfere with safe machine operation.
- Never allow children to operate the machine.
- Use extra care when approaching blind corners, shrubs, trees, or other objects that may obscure vision.

IV. SERVICE:

- Use extra care in handling gasoline and other fuels. They are flammable and vapors are explosive.
 - a. Use only an approved container.
 - b. Never remove gas cap or add fuel with the engine running. Allow engine to cool before refueling. Do not smoke.
 - c. Never refuel the machine indoors.
 - d. Never store the machine or fuel container inside where there is an open flame, such as in a water heater.
- Check fuel supply before each use allowing space for expansion as the heat of the engine and/or sun can cause gasoline to expand and overflow the tank.
- Use extra care when handling battery acid. Acid contact with skin may cause severe burns. Eye contact may cause blindness.
- Use extra care when servicing the battery. Explosive gas is produced in the battery. Do not service the battery while smoking or near an open spark or flame. This may cause the battery to explode causing serious injury.
- Never run a machine inside a closed area. Exhaust fumes contain CARBON MONOXIDE, an ODORLESS and DEADLY GAS.
- Keep nuts and bolts, especially blade attachment bolts, tight and keep equipment in good condition.
- Never tamper with safety devices. Check their operation regularly.
- Do not change the engine governor settings or overspeed engine.
- Reduce fire hazards. Keep machine free of grass, leaves, or other debris build-up. Clean up oil or fuel spillage. Allow machine to cool before storing.
- Stop and inspect the equipment if you strike an object. Repair, if necessary, before restarting.
- Never make adjustments or repairs with the engine running.
- Grass catcher components are subject to wear, damage, and deterioration, which could expose moving parts or allow objects to be thrown. Frequently check components and replace with manufacturer's recommended parts, when necessary.
- Mower blade(s) are sharp and can cut. Wrap the blade(s) or wear gloves, and use extra caution when servicing them.
- Check brake operation frequently. Adjust and service as required.



LOOK FOR THIS SYMBOL TO POINT OUT IMPORTANT SAFETY PRECAUTIONS. IT MEANS--ATTENTION!!!
BECOME ALERT!!! YOUR SAFETY IS INVOLVED.

E3595-080

OWNER'S INFORMATION

Record the following information about your unit so that you will be able to provide it in case of loss or theft.

MODEL NUMBER: - (Enter complete 8 digit number from model plate on unit)

PURCHASE DATE: ___ / ___ / ___ CODE NO.: _____ SERIAL NO.: _____

DEALER'S NAME AND ADDRESS: _____

CITY: _____ STATE: _____ TELEPHONE: _____

TOOLS REQUIRED FOR ASSEMBLY

- 2 - 7/16 inch Wrenches (or adjustable wrench)
- 1 - 1/2 inch Wrench (or adjustable wrench)
- 1 - Small Phillips Screwdriver with a 1/4 inch shank
- 1 - Hammer

SHIPPING CONTENTS

See Customer Assembly on page 26 & 27 for Seat & Hardware

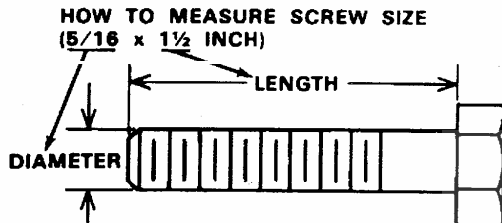

DANGER



This lawn tractor can be dangerous if carelessly used.

Read your Operator's Manual thoroughly before operating your lawn tractor.

Always wear safety glasses or eye shields while assembling or operating your lawn tractor.

DO NOT carry passengers at any time.

Keep your hands, feet, hair and loose clothing away from the discharge area, the underside of the mower deck or any moving parts while the engine is running.

DO NOT allow children or young teenagers to operate or be near your lawn tractor while it is operating.

- ALWAYS GIVE THE FOLLOWING INFORMATION WHEN ORDERING REPAIR PARTS:
1. The PART NUMBER; 2. The PART NAME; 3. QUANTITY DESIRED; 4. The MODEL NUMBER (As shown on Model Plate).
- SEND PART ORDERS AS PER INSTRUCTIONS ON THE FRONT PAGE.
- DO NOT USE KEY NUMBERS WHEN ORDERING REPAIR PARTS, ALWAYS USE PART NUMBERS.
- All replacement parts will be supplied in current production colors or in a neutral color.
A handling fee is applicable to small parts orders.
- YOUR UNIT IS RIGHT HAND (RH) OR LEFT HAND (LH) AS YOU STAND BEHIND IT.

E3595-080

REPAIR PARTS

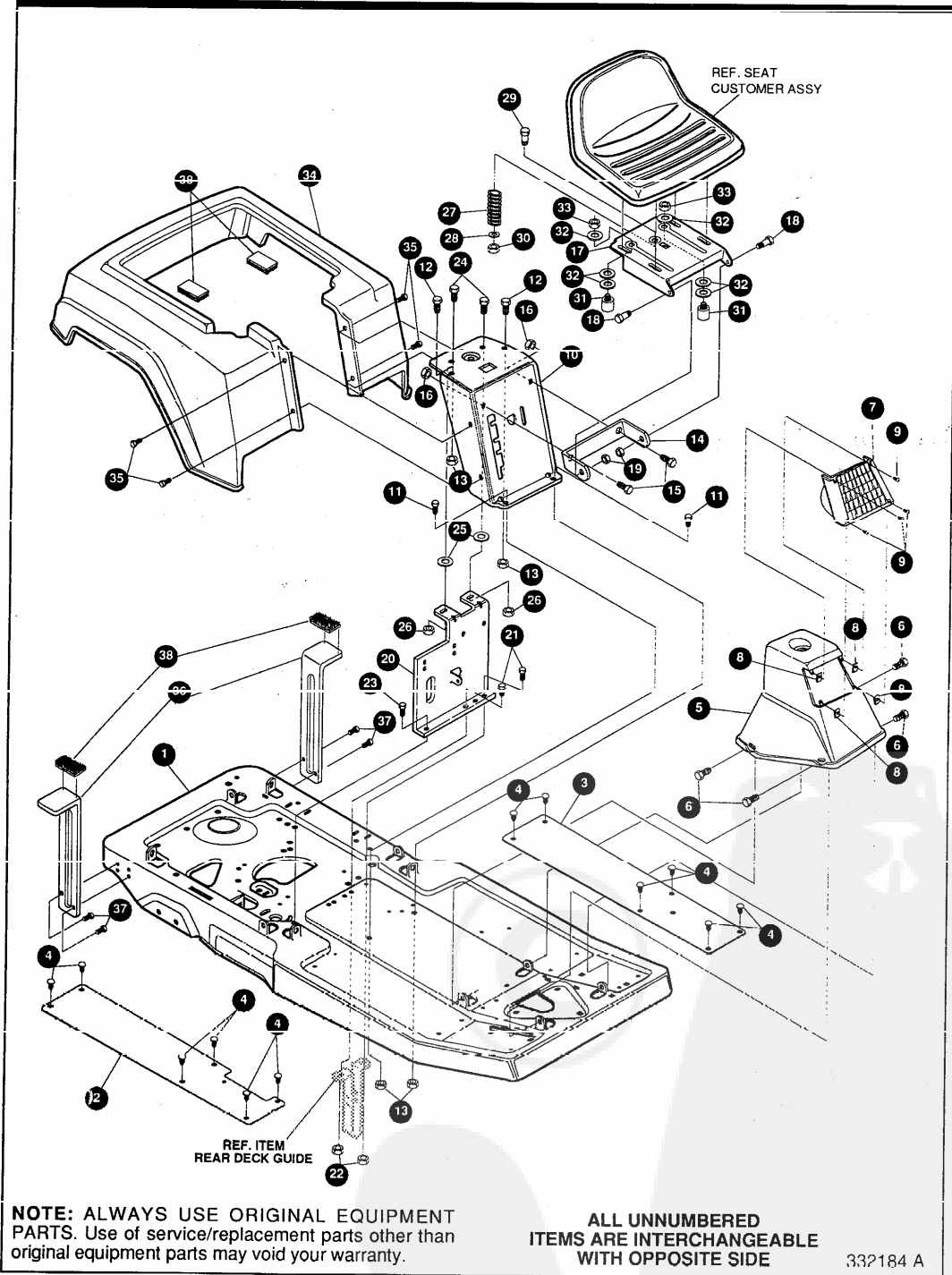

NOTE: ALWAYS USE ORIGINAL EQUIPMENT PARTS. Use of service/replacement parts other than original equipment parts may void your warranty.

ALL UNNUMBERED ITEMS ARE INTERCHANGEABLE WITH OPPOSITE SIDE

332184 A

E3595-080

BODY GROUP ASSEMBLY

KEY#	PART#	DESCRIPTION	QTY
1	314227-860	FRAME RER	1
2	309612	FOOT PAD, RH NOMA 8/32 RER BLK	1
3	309613	FOOT PAD, LH NOMA 8/32 RER BLK	1
4	309235	FASTENER, RATCHET BLACK	12
5	302805	CONSOLE C-2 NOMA RER	1
6	995346	SCREW, 1/4-20X .50 WAHTAP	4
7	303130	HEADLIGHT ASSY NOMA RER	1
8	303260	CLIP, TINNERMAN	4
9	308347	SCREW, #6-32X .50 PHPNHMA	4
10	330969-860	SUPPORT, SEAT W/LFT SLOT	1
11	48901	SCREW, 5/16-18X .63WAHHC	2
12	180077	SCREW, 5/16-18X .75 HHC	2
13	1498	NUT, 5/16-18 REGHEXCTRLK	4
14	301330-853	SEAT BRACKET	1
15	180120	SCREW, 3/8-16X .75 HHC	2
16	1499	NUT, 3/8-16 REGHXCTRLK	2
17	313476-853	SEAT PLATE	1
18	20507	BOLT, .437X .156 HSH 5/16-18	2
19	1498	NUT, 5/16-18 REGHEXCTRLK	2
20	331106-853	SEAT/SHIFT SUPPORT FOR M#28	1
21	180079	SCREW, 5/16-18X1.00 HHC	2
22	1498	NUT, 5/16-18 REGHEXCTRLK	2
23	35498	SCREW, 5/16-18X .75 WAHTAP	1
24	180077	SCREW, 5/16-18X .75 HHC	2
25	45602	WASHER, FLAT .333X .87X.119	2
26	1498	NUT, 5/16-18 REGHEXCTRLK	2
27	319136	SPRING, COMP. .97X2.00X.095	1
28	120392	WASHER, FLAT .281X .63X.065	1
29	180016	SCREW, 1/4-20X .50 HHC	1
30	1502	NUT, 1/4-20 REGHEXCTRLK	1
31	53446	PIN, 5/16-18 HOOD LATCH	2
32	120386	WASHER, FLAT .312X .73X.065	6
33	124824	NUT, 5/16-18 HEXJAM	2
34	992805	FENDER, REP	1
35	44811	SCREW, 1/4-20X .75 WAHTAP	4
36	305645	FENDER SUPPORT	2
37	995346	SCREW, 1/4-20X .50 WAHTAP	4
38	12599	FASTENER, VELCRO, 2" X 1"	2
39	333481	PARTS MANUAL	1
40	329374	OPERATOR'S MANUAL (ENGLISH)	1
41	329376	OPERATOR'S MANUAL (FRENCH)	1
42	329377	OPERATOR'S MANUAL (GERMAN)	1
43	318307	GRASS CATCHER MANUAL (ENGLISH)	1
44	318354	GRASS CATCHER MANUAL (FRENCH)	1
45	318355	GRASS CATCHER MANUAL (GERMAN)	1

E3595-080

REPAIR PARTS

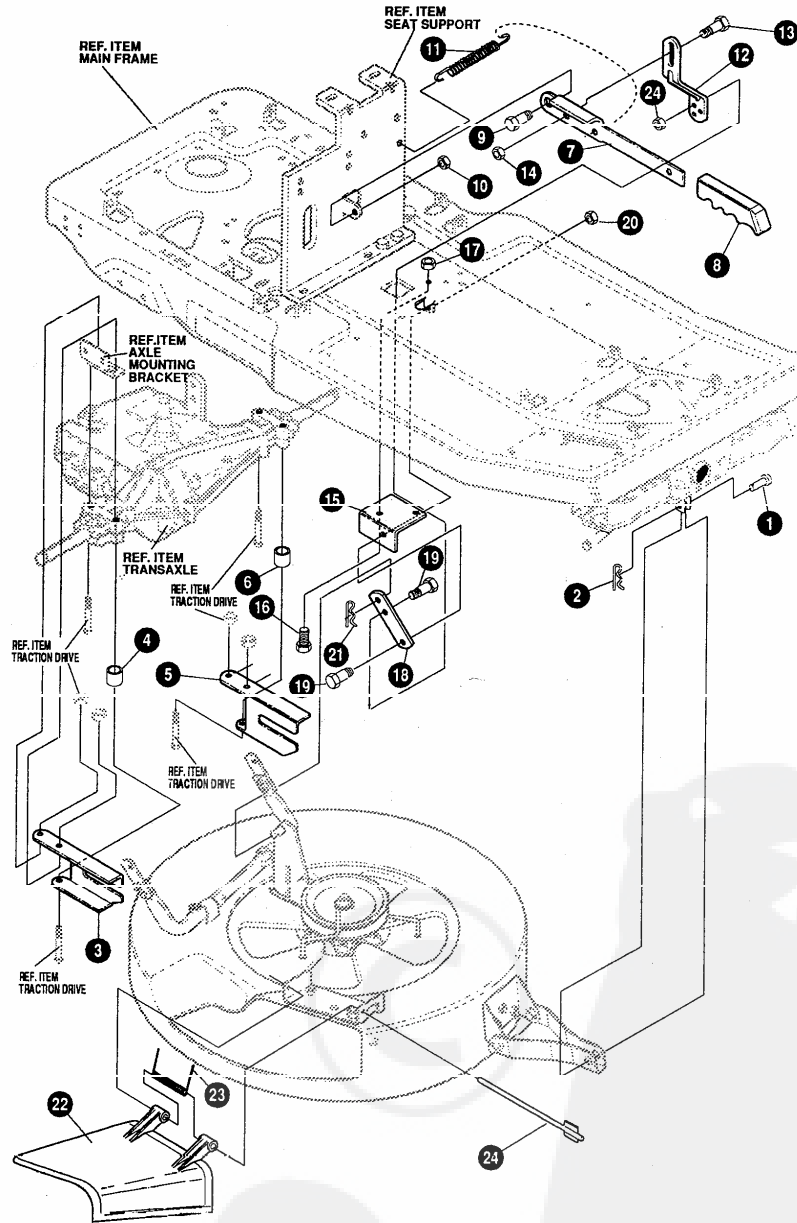

NOTE: ALWAYS USE ORIGINAL EQUIPMENT PARTS. Use of service/replacement parts other than original equipment parts may void your warranty.

ALL UNNUMBERED ITEMS ARE INTERCHANGEABLE WITH OPPOSITE SIDE

331490 A

E3595-080**MOWER SUSPENSION ASSEMBLY**

KEY#	PART#	DESCRIPTION	QTY
1	47817	PIN, CLEVIS LONG.....	1
2	8260	PIN, HAIR .091 DIA X 1.66LG.....	1
3	321371	BRKT, REAR SUPT RH.....	1
4	41462	SPACER, SLEV .328X .75X .312PM.....	1
5	321370	BRKT, REAR SUPT LH.....	1
6	41462	SPACER, SLEV .328X .75X .312PM.....	1
7	313719-853	HANDLE, HEIGHT ADJUST.....	1
8	313763	GRIP, HANDLE, LIFT.....	1
9	54855	BOLT, .500X .345 HSSH 3/8-16.....	1
10	1499	NUT, 3/8-16 REGHXCTRLK.....	1
11	35410	SPRING .071 X .62 X 4.37.....	1
12	323897	BRKT, LINK UPPER BLK.....	1
13	54855	BOLT, .500X .345 HSSH 3/8-16.....	1
14	1499	NUT, 3/8-16 REGHXCTRLK.....	1
15	323898	BRKT, RER FRAME BLK.....	1
16	180079	SCREW, 5/16-18X1.00 HHC.....	1
17	1498	NUT, 5/16-18 REGHEXCTRLK.....	1
18	323899	BRKT, LINK LOWER BLK.....	1
19	313560	BOLT, .500X .225 HSSH 5/16-18.....	2
20	1498	NUT, 5/16-18 REGHEXCTRLK.....	2
21	56180	PIN, HAIR .091 DIA X 1.62LG.....	1
22	315314	CHUTE DEFLECTOR 30" DECK.....	1
23	314975	SPRING, TORSION CHUTE DEFLECTOR.....	1
24	304424	ROD, PIVOT DECK .312DX7.25.....	1

E3595-080

REPAIR PARTS

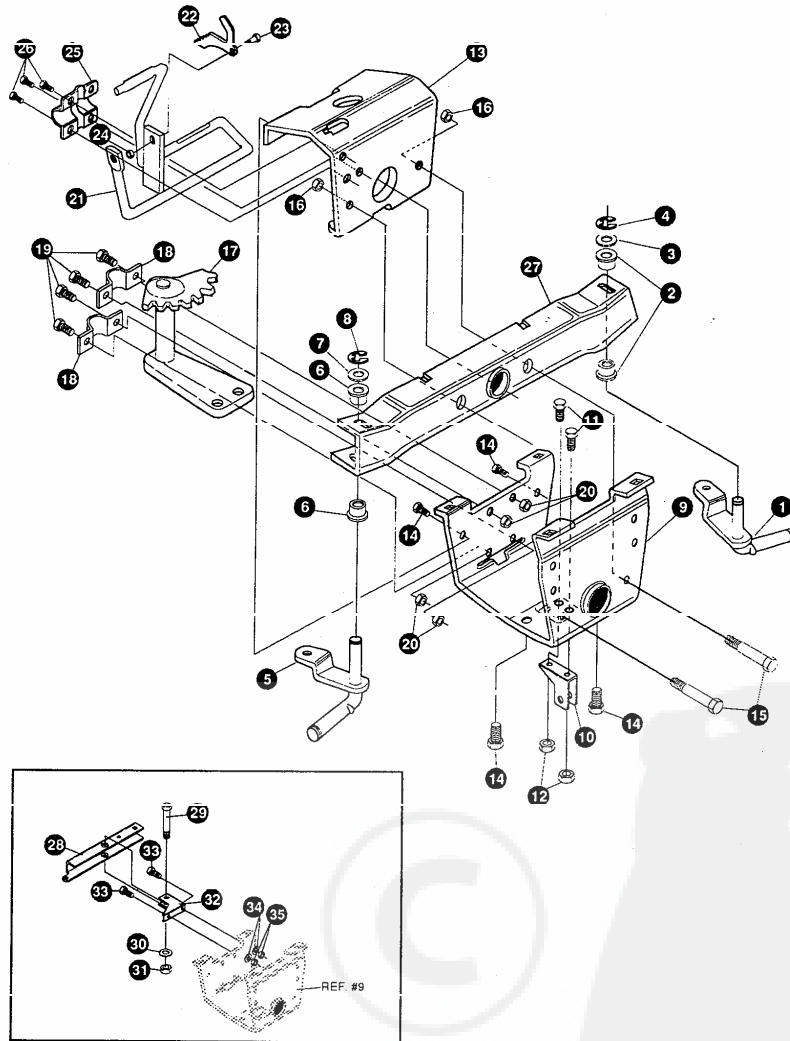

NOTE: ALWAYS USE ORIGINAL EQUIPMENT PARTS. Use of service/replacement parts other than original equipment parts may void your warranty.

ALL UNNUMBERED ITEMS ARE INTERCHANGEABLE WITH OPPOSITE SIDE

316219 D

E3595-080**PRE-PAINTED FRONT AXLE ASSEMBLY**

KEY#	PART#	DESCRIPTION	QTY
1	316216	ASSY SPINDLE L.H. 30,36 RER	1
2	12552	BUSHING, SPINDLE	2
3	4107	WASHER, FLAT .635X1.31X.07	2
4	20859	RING, RET E .48X.04TRU5133-62	1
5	316217	ASSY SPINDLE R.H. 30,36 RER	1
6	12552	BUSHING, SPINDLE	2
7	4107	WASHER, FLAT .635X1.31X.07	2
8	20859	RING, RET E .48X.04TRU5133-62	1
9	314228	BRACKET, AXLE, OUTER, FRONT	1
10	323304	HANGER, BLK	1
11	180077	SCREW, 5/16-18X .75 HHC	2
12	1498	NUT, 5/16-18 REGHEXCTRLK	2
13	302799	AXLE BRACKET, INNER	1
14	35497	SCREW, 5/16-18X .50 WAHTAP	4
15	180138	SCREW, 3/8-16X3.00 HHC	2
16	1499	NUT, 3/8-16 REGHXCTRLK	2
17	302958	STEERING ASSY RER	1
18	302760	CLAMP .625DIA	2
19	180077	SCREW, 5/16-18X .75 HHC	4
20	1498	NUT, 5/16-18 REGHEXCTRLK	4
21	303249	BRAKE ARM ASSY	1
22	302955	LATCH, PARKING BRAKE	1
23	3275	BOLT, .373X .140 HSSH 1/4-20	1
24	1502	NUT, 1/4-20 REGHEXCTRLK	1
25	44112	BRKT. CLUTCH & BRAKE	1
26	35497	SCREW, 5/16-18X .50 WAHTAP	4
27	323904	HANGER, BLK	1
28	309051	ROCKER ARM, MOWER ENGAGEMENT	1
29	310364	BOLT, .500X1.18 HSSH 3/8-16	1
30	845	WASHER, FLAT .390X1.25X.119	1
31	1499	NUT, 3/8-16 REGHXCTRLK	1
33	180077	SCREW, 5/16-18X .75 HHC	2
34	120393	WASHER, FLAT .344X .69X.065	2
35	1498	NUT, 5/16-18 REGHEXCTRLK	2

E3595-080

REPAIR PARTS

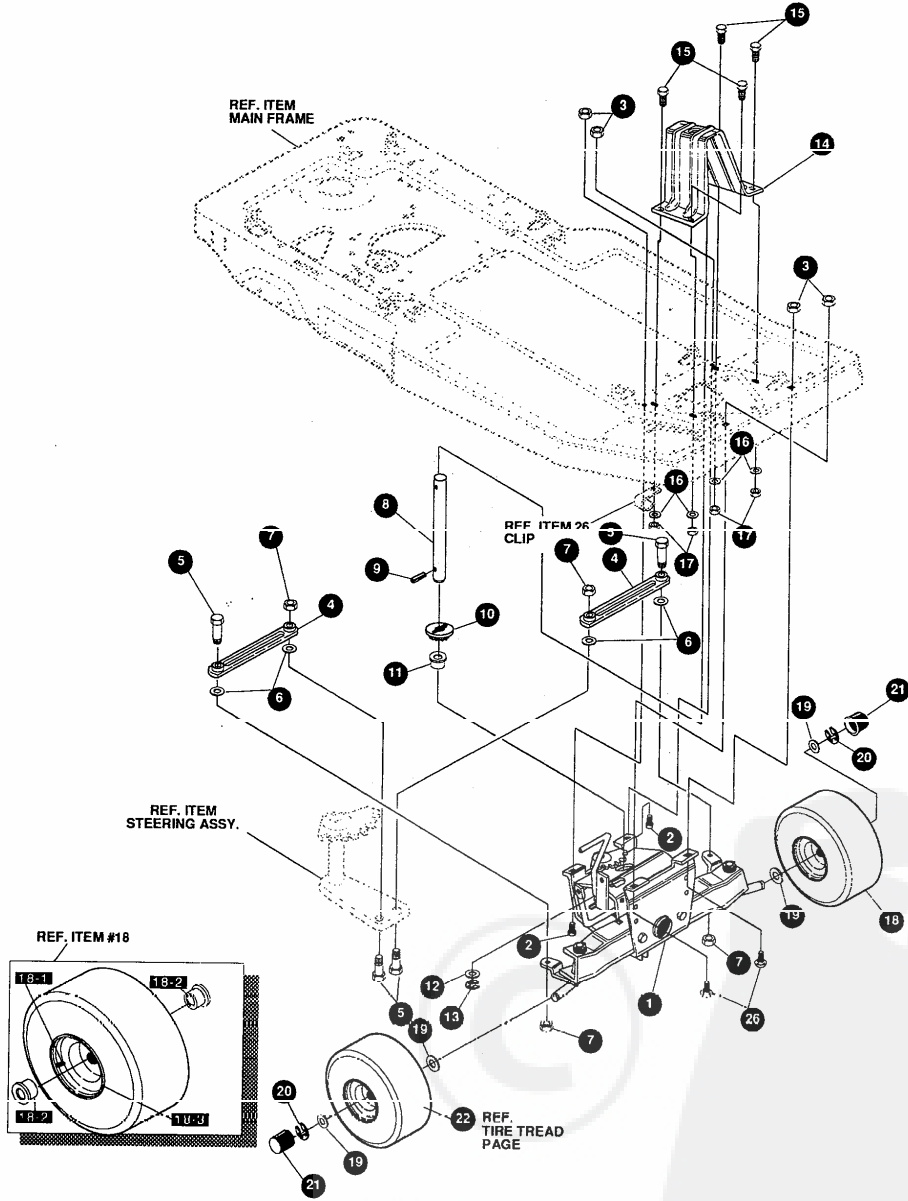

NOTE: ALWAYS USE ORIGINAL EQUIPMENT PARTS. Use of service/replacement parts other than original equipment parts may void your warranty.

ALL UNNUMBERED ITEMS ARE INTERCHANGEABLE WITH OPPOSITE SIDE

316220 F

E3595-080**FRONT AXLE & WHEELS ASSEMBLY**

KEY#	PART#	DESCRIPTION	QTY
1	^	ACCY., FRONT AXLE PIVOTING	1
2	57072	BOLT, 5/16-18X .63 CARRLN	2
3	45174	NUT, 5/16-18 HEXWDFLLK WHIZ	4
4	303140	TIE ROD, RER	2
5	180124	SCREW, 3/8-16X1.25 HHC	4
6	120382	WASHER, REGSPTLK.393X.68X.10	4
7	1499	NUT, 3/8-16 REGHXCTRLK	4
8	323906	SHAFT, STEERING BLK	1
9	454565	PIN, SPRING.250DIAX1.25LG HVPL	1
10	302766	GEAR, PINION	1
11	304010	BUSHING-STEERING	1
12	4107	WASHER, FLAT .635X1.31X.07	1
13	20859	RING, RET E .48X.04TRU5133-62	1
14	306553	SUPPORT, STEERING BLK 853	1
15	48901	SCREW, 5/16-18X .63WAHHC	4
16	120393	WASHER, FLAT .344X .69X.065	4
17	1498	NUT, 5/16-18 REGHEXCTRLK	4
18	305508	TIRE & RIM, PU 11X4.0X5 TUR	2
18-1	24167	VALVE STEM	
18-2	301137	BEARING	
18-3	301175	RIM, WHEEL	
19	40077	WASHER, FLAT .640X1.25X.06 PL	4
20	20859	RING, RET E .48X.04TRU5133-62	2
21	36832	HUB CAP, PLAS BLACK	2
22		REFER TO TIRE TREAD PAGE	
26	180077	SCREW, 5/16-18X .75 HHC	2

^ ORDER INDIVIDUAL PARTS

E3595-080

REPAIR PARTS

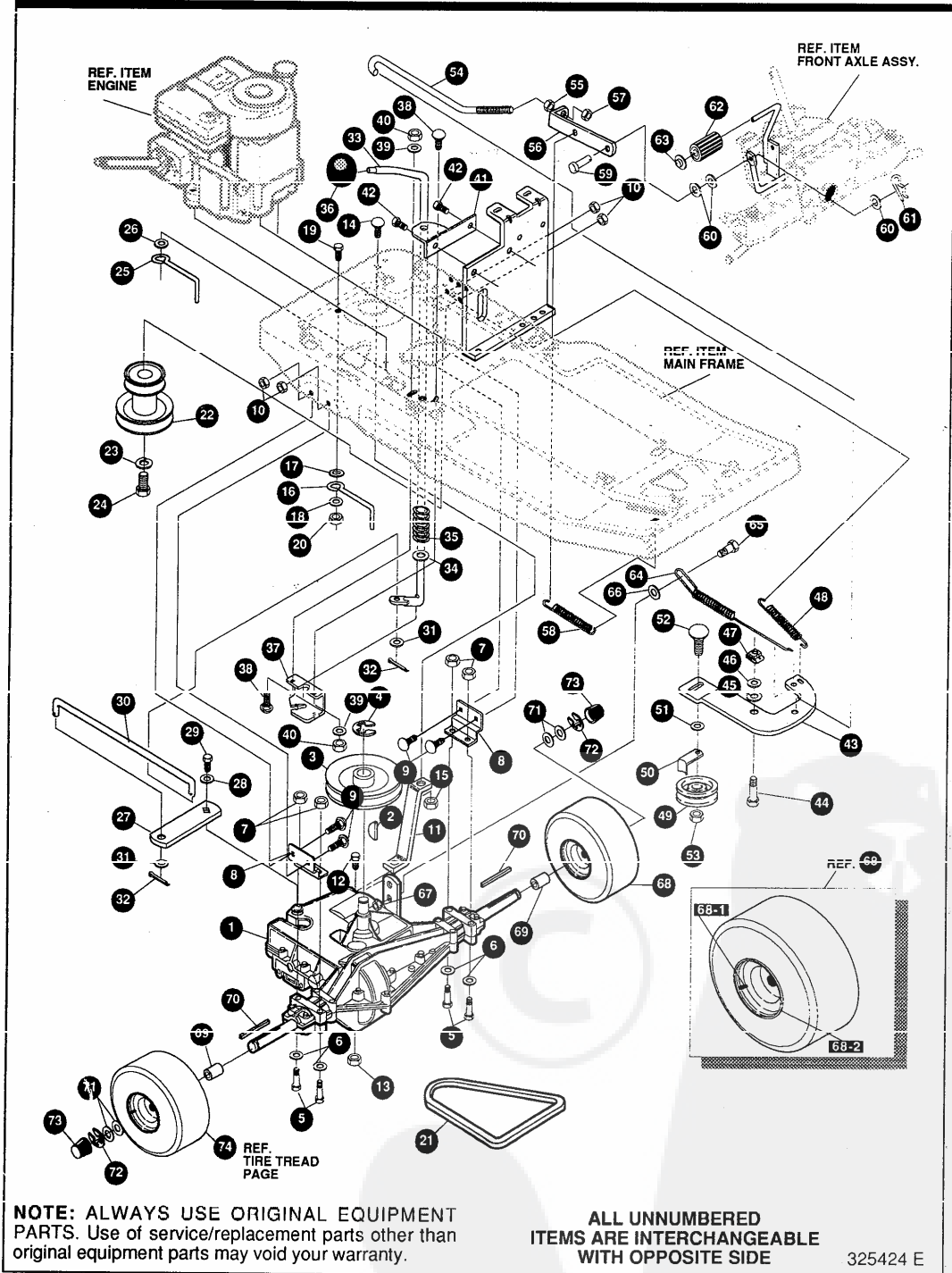

E3595-080

TRACTION DRIVE ASSEMBLY

KEY#	PART#	DESCRIPTION	QTY
1	^	TRANSAXLE, P915-005 SPEED RER	1
2	50795	KEY, HI-PRO 606 .75DIA X 1.87WD	1
3	303109	PULLEY, 6.6 OD V4L T/A	1
4	22053	RING, RETEX .58X.035TRU5100-62	1
5	180113	SCREW, 5/16-18X3.00 HHC	4
6	120393	WASHER, FLAT .344X .69X.065	4
7	1498	NUT, 5/16-18 REGHEXCTRLK	4
8	9798	BRKT, TRANSAXLE	2
9	57072	BOLT, 5/16-18X .63 CARRLN	4
10	1498	NUT, 5/16-18 REGHEXCTRLK	4
11	324199	BRKT, TRNSXL SUPT	1
12	180087	SCREW, 5/16-18X2.00 HHC	1
13	1498	NUT, 5/16-18 REGHEXCTRLK	1
14	57072	BOLT, 5/16-18X .63 CARRLN	1
15	1498	NUT, 5/16-18 REGHEXCTRLK	1
16	55488	BELT GUIDE	1
17	138489	WASHER, EXLK .384X.69X.04	1
18	120394	WASHER, FLAT .406X .81X.065	1
19	180079	SCREW, 5/16-18X1.00 HHC	1
20	1498	NUT, 5/16-18 REGHEXCTRLK	1
21	300575	BELT, V 4L 34.00	1
22	328040	PULLY, ENG3.315OF/5.5D/3.00D	1
23	120383	WASHER, REGSPTLK.459X.78X.12	1
24	182761	SCREW, 7/16-20X2.50 HHC	1
25	55488	BELT GUIDE	1
26	138489	WASHER, EXLK .384X.69X.04	1
27	300585	BRACKET, SHIFT LEVER	1
28	57157	WASHER, 750X.250 SP-TRANSAXLE	1
29	56255	SCREW, 1/4-28X .75 NYLHHC	1
30	321482	ROD, CONNECTING, SHIFT	1
31	120394	WASHER, FLAT .406X .81X.065	2
32	137105	PIN, COTTER .125 DIA X 1.66LG	2
33	309255	HANDLE, SHIFT	1
34	120396	WASHER, FLAT .531X1.06X.095	1
35	301133	SPRING, SHIFT LVR	1
36	55514	KNOB, ROUND 1.50 DIA BLACK	1
37	309053	BRACKET, DETENT SHIFT	1
38	126216	BOLT, 5/16-18X .75 CARRLN	2
39	120393	WASHER, FLAT .344X .69X.065	2
40	1498	NUT, 5/16-18 REGHEXCTRLK	2
41	303098-853	BRACKET, SHIFT CONTROL	1
42	995346	SCREW, 1/4-20X .50 WAHTAP	2
43	12593	PIVOT ARM, IDLER	1
44	329989	BOLT, .625X .139 HSSH 5/16-18	1
45	4107	WASHER, FLAT .635X1.31X.07	1
46	45602	WASHER, FLAT .333X .87X.119	1
47	301124	TINNERMAN CLIP	1
48	35410	SPRING .071 X .62 X 4.37	1
49	35374	PULLEY, IDLER V4L 3.06X .62	1
50	39659	RETAINER, BELT	1
51	274517	WASHER, FLAT .406X .79X.063	1
52	45892	BOLT, 3/8-16X1.50 CARRSN	1
53	1499	NUT, 3/8-16 REGHXCTRLK	1
54	323532	ROD, CLUTCH RER BLK	1
55	271184	NUT, 5/16-18 HEXKEPS	1
56	321378	BRKT, CLUTCH BRAKE	1
57	1498	NUT, 5/16-18 REGHEXCTRLK	1
58	313854	IDLER SPRING	1
59	39522	PIN, CLEVIS .312 X .812	1
60	120393	WASHER, FLAT .344X .69X.065	3
61	8260	PIN, HAIR .091 DIA X 1.66LG	1
62	52840	FOOT PEDAL	1
63	44582	CAP, PUSH-ON FITS 7/16 ROD	1
64	326856	SPRING, BRAKE P915 11.37"	1
65	326131	BOLT, .495X .31 HSSH5/16-18	1
66	308188	WASHER, FLAT .515X1.31X.09	1
67	1498	NUT, 5/16-18 REGHEXCTRLK	1
68	41082	TIRE & RIM, PU 16X6.5X8 TUR	2
68-1	24167	VALVE STEM	
68-2	305036	RIM, WHEEL	
69	300588	SPACER, AXLE	2
70	52928	KEY, SQUARE .187SQ X 2.25LG	2
71	42815	WASHER, FLAT .755X1.53X.07	4
72	36625	RING, RETEX .57X.05TRU5133-75	2
73	40394	HUB CAP, 1.500ID X 7/8LG	2
74		REFER TO TIRE TREAD PAGE	

^ CONTACT YOUR NEAREST TRANSAXLE DEALER FOR PARTS AND SERVICE

E3595-080

REPAIR PARTS

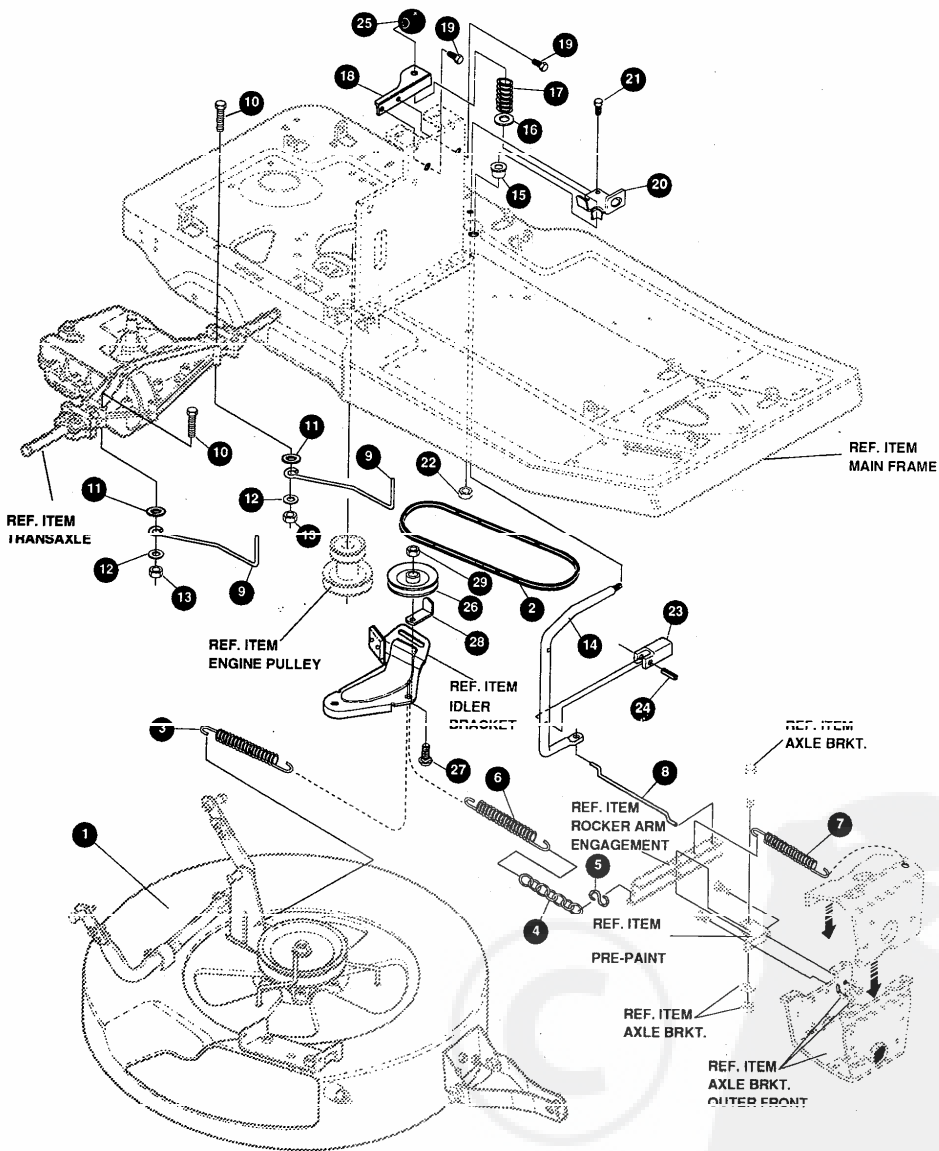

NOTE: ALWAYS USE ORIGINAL EQUIPMENT PARTS. Use of service/replacement parts other than original equipment parts may void your warranty.

ALL UNNUMBERED ITEMS ARE INTERCHANGEABLE WITH OPPOSITE SIDE

331748 A

E3595-080**MOWER DRIVE ASSEMBLY**

KEY#	PART#	DESCRIPTION	QTY
1	317798-853	ASSY., DECK, PRE-PAINT 30".....	1
2	56537	BELT, V 4L 50.5LG.....	1
3	35410	SPRING .071 X .62 X 4.37.....	1
4	310428	CHAIN, JACK,.....	50
5	310734	HOOK, S, 10 GA. STEEL.....	1
6	300683	SPRING, .75X6.3X.105 TENSION.....	1
7	35410	SPRING .071 X .62 X 4.37.....	1
8	309049	ROD, CONNECTING.....	1
9	310388	GUIDE BELT.....	2
10	180091	SCREW, 5/16-18X2.50 HHC.....	2
11	138485	WASHER, EXLK .320X.61X.03.....	2
12	120393	WASHER, FLAT .344X .69X.065.....	2
13	1498	NUT, 5/16-18 REGHEXCTRLK.....	2
14	309048	HANDLE, MOWER ENGAGEMENT.....	1
15	310351	BRNG, FL .IDX. ODXPLAS.....	1
16	304291	SPRING, RETAINING.....	1
17	304398	SPRING COMPRESSION.....	1
18	311107-853	SUPPORT BRACKET PTO.....	1
19	995346	SCREW, 1/4-20X .50 WAHHTAP.....	2
20	310309	BRACKET, PTO LIMIT.....	1
21	35498	SCREW, 5/16-18X .75 WAHHTAP.....	1
22	1498	NUT, 5/16-18 REGHEXCTRLK.....	1
23	305225	STOP, PTO ENGAGE.....	1
24	326386	PIN, SPRING.187DIA X1.13LG HD.....	1
25	55514	KNOB, ROUND 1.50 DIA BLACK.....	1
26	45074	PULLEY, IDLER V4L 3.06X .72.....	1
27	45892	BOLT, 3/8-16X1.50 CARRSN.....	1
28	39659	RETAINER,BELT.....	1
29	1499	NUT, 3/8-16 REGHXCTRLK.....	1

E3595-080

REPAIR PARTS

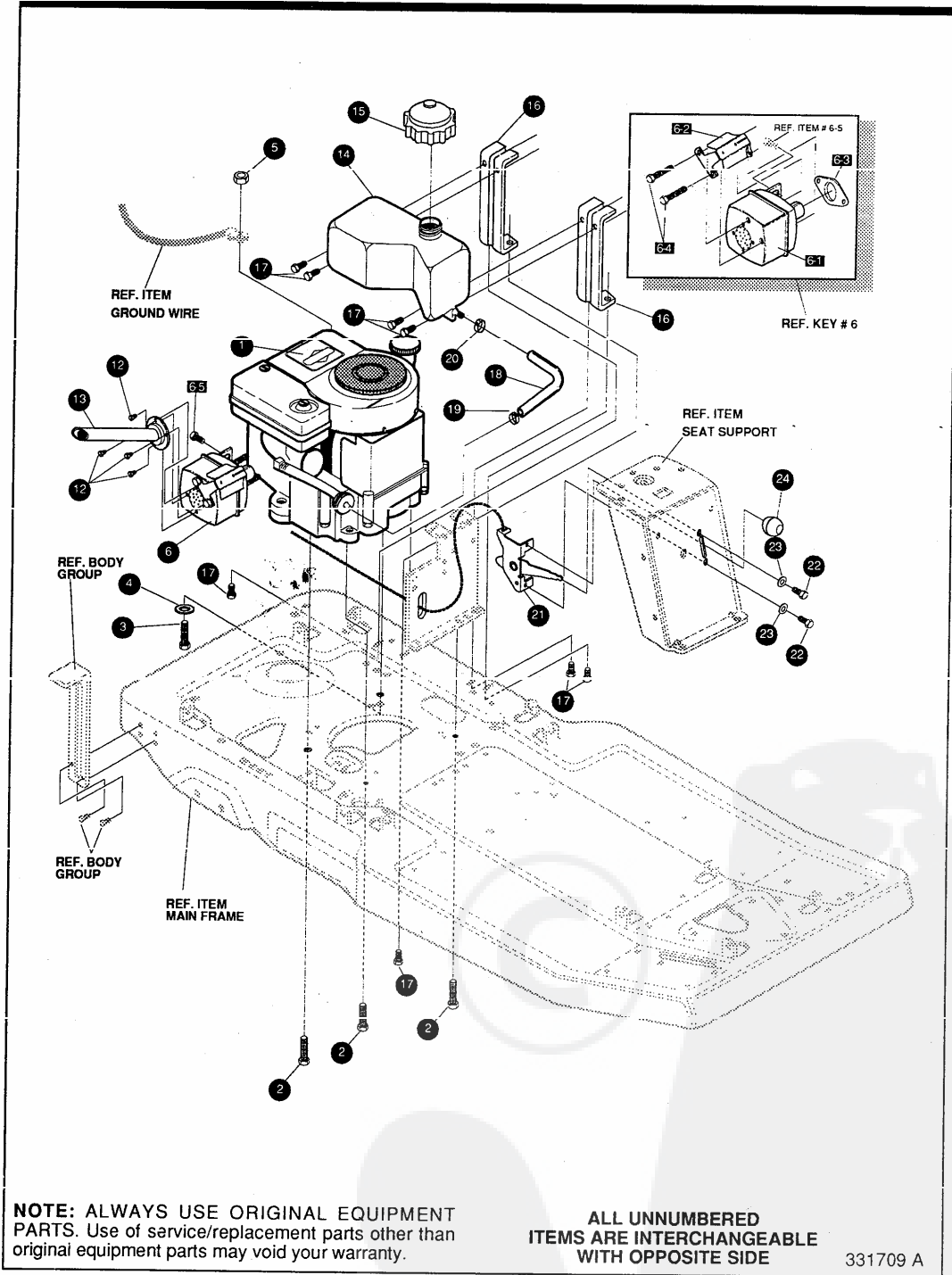

NOTE: ALWAYS USE ORIGINAL EQUIPMENT PARTS. Use of service/replacement parts other than original equipment parts may void your warranty.

ALL UNNUMBERED ITEMS ARE INTERCHANGEABLE WITH OPPOSITE SIDE

331709 A

E3595-080**ENGINE & CONTROL ASSEMBLY**

KEY#	PART#	DESCRIPTION	QTY
1	ENGINE	10-12HP B&S 3A(SEE ENGINE MANUAL).....	1
2	50947	SCREW, 3/8-16X1.25 WAHHTAP.....	3
3	180083	SCREW, 5/16-18X1.50 HHC.....	1
4	138485	WASHER, EXLK .320X.61X.03.....	1
5	44108	NUT, 5/16-18 HWDFLCTRLK.....	1
6	305404	MUFFLER ASSY B&S SQ. LO-TONE.....	1
6-1	305406	MUFFLER B&S SQ. LO-TONE 10-12HP.....	1
6-2	305409	SHIELD, MUFFLER B&S SQ. LO-TONE.....	1
6-3	46708	GASKET, MUFFLER.....	1
6-4	305407	BOLT, 437X4.340 HSH5/16-18BL.....	2
6-5	305410	SCREW, 1/4-20X .50 HHCSEMS.....	1
12	57366	SCREW, 10-16X .50 DRILLTITE.....	4
13	311721-050	PIPE ASSY, 10 B&S EXHAUST.....	1
14	314986	TANK, GAS-NOMA, 1.3 GAL, F-12.....	1
15	12501	CAP, FUEL 2.5" THROAT.....	1
16	313150-853	SUPPORT, GAS TANK F-12.....	2
17	995346	SCREW, 1/4-20X .50 WAHHTAP.....	8
18	47216	TUBING, .25X.50X BULK GAS LINE.....	22.0
19	47345	CLAMP, HOSE SCREW TYPE.....	1
20	47345	CLAMP, HOSE SCREW TYPE.....	1
21	321240	THROTTLE CONTROL RER.....	1
22	35287	SCREW, #8-32X .38 HHWTAP.....	2
23	414106	WASHER, FLAT .188X .38X .040.....	2
24	50607	KNOB, ROUND THROTTLE BLACK.....	1

E3595-080

REPAIR PARTS

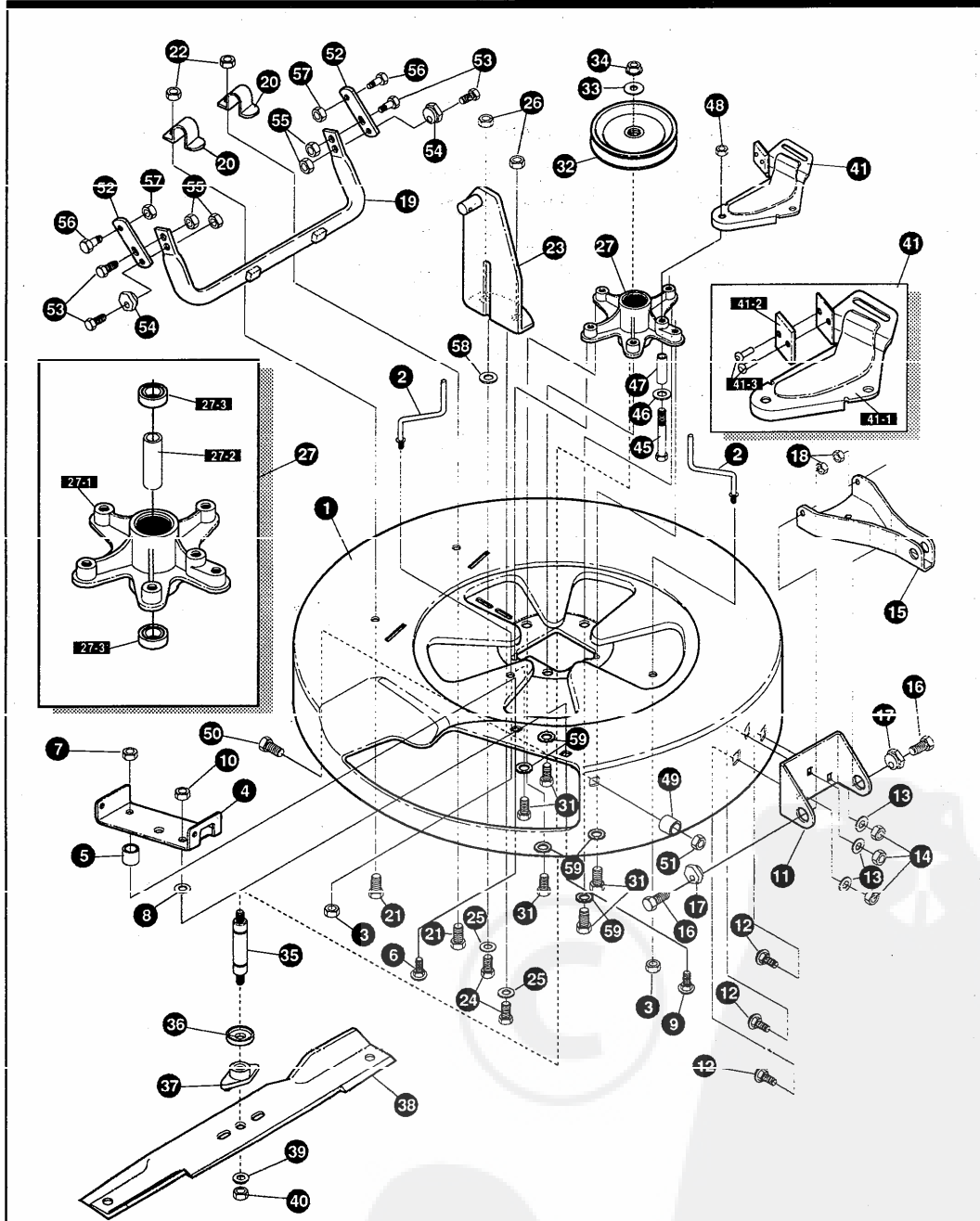

NOTE: ALWAYS USE ORIGINAL EQUIPMENT PARTS. Use of service/replacement parts other than original equipment parts may void your warranty.

ALL UNNUMBERED ITEMS ARE INTERCHANGEABLE WITH OPPOSITE SIDE

313589 E

E3595-080**PRE-PAINTED DECK ASSEMBLY**

KEY#	PART#	DESCRIPTION	QTY
1	321982-853	DECK, MOWER 30" S.F./RER	1
2	57318	GUIDE, BELT 5/16-18 THD	2
3	1498	NUT, 5/16-18 REGHEXCTRLK	2
4	317017	BRACKET CHUTE MOUNT BLACK	1
5	314702	SPACER, SLEV .344X1.00X.500	1
6	120230	BOLT, 5/16-18X1.25 CARRLN	1
7	1498	NUT, 5/16-18 REGHEXCTRLK	1
8	45602	WASHER, FLAT .333X.87X.119	1
9	126216	BOLT, 5/16-18X.75 CARRLN	1
10	1498	NUT, 5/16-18 REGHEXCTRLK	1
11	311237-853	BRACKET, MOUNTING, FRONT	1
12	57072	BOLT, 5/16-18X.63 CARRLN	3
13	120393	WASHER, FLAT .344X.69X.065	3
14	1498	NUT, 5/16-18 REGHEXCTRLK	3
15	311236-853	BRACKET, BAR, TOW, FRONT	1
16	180079	SCREW, 5/16-18X1.00 HHC	2
17	58247	NUT, ADJUST	2
18	1498	NUT, 5/16-18 REGHEXCTRLK	2
19	313372-853	ASSY., TUBE, PIVOT	1
20	310672	SUPPORT, PIVOT TUBE BLK	2
21	180077	SCREW, 5/16-18X.75 HHC	2
22	1498	NUT, 5/16-18 REGHEXCTRLK	2
23	314119-853	ASSY LIFT BRKT.	1
24	180077	SCREW, 5/16-18X.75 HHC	2
25	120393	WASHER, FLAT .344X.69X.065	2
26	1498	NUT, 5/16-18 REGHEXCTRLK	2
27	313588	ASSEMBLY, QUILL	1
27-1	314272	QUILL, MACHINED CASTING	1
27-2	314274	TUBE, SPACER, STEEL	1
27-3	313576	BRNG, BALL 6204-2AA-C3	2
32	314273	PULLEY ASSEMBLY	1
33	22265	WASHER, FLAT .515X1.38X.119	1
34	1500	NUT, 1/2-13 REGHCTRLK	1
35	314271	SHAFT, QUILL 30" MOWER	1
36	313577	SHIELD, DUST, BEARING	1
37	313584	HUB, BLADE ADAPTOR	1
38	329988	BLADE, 30" TD MOWER 0.7 WING	1
39	22265	WASHER, FLAT .515X1.38X.119	1
40	1500	NUT, 1/2-13 REGHCTRLK	1
41	12229-853	BRACKET, IDLER ASSEMBLY	1
41-1	313510-853	BRACKET, ARM, IDLER	1
41-2	306973	BRAKE PAD - HARD - 232AF	1
41-3	41601	RIVET, OVSET .187DIA X .50LG ST	2
45	180091	SCREW, 5/16-18X2.50 HHC	1
46	45602	WASHER, FLAT .333X.87X.119	1
47	314824	SPACER, SLEV .322X.63X1.810	1
48	44108	NUT, 5/16-18 HWDFLCTRLK	1
49	50520	SPACER	1
50	126216	BOLT, 5/16-18X.75 CARRLN	1
51	1498	NUT, 5/16-18 REGHEXCTRLK	1
52	314099-853	BRACKET, BAR, REAR STABIL	2
53	180079	SCREW, 5/16-18X1.00 HHC	4
54	58247	NUT, ADJUST	2
55	1498	NUT, 5/16-18 REGHEXCTRLK	4
56	51940	BOLT, .500X.437 HSH 3/8-16	2
57	1498	NUT, 3/8-16 REGHXCTRLK	2
58	45602	WASHER, FLAT .333X.87X.119	1
59	138485	WASHER, EXLK .320X.61X.03	5

E3595-080

REPAIR PARTS

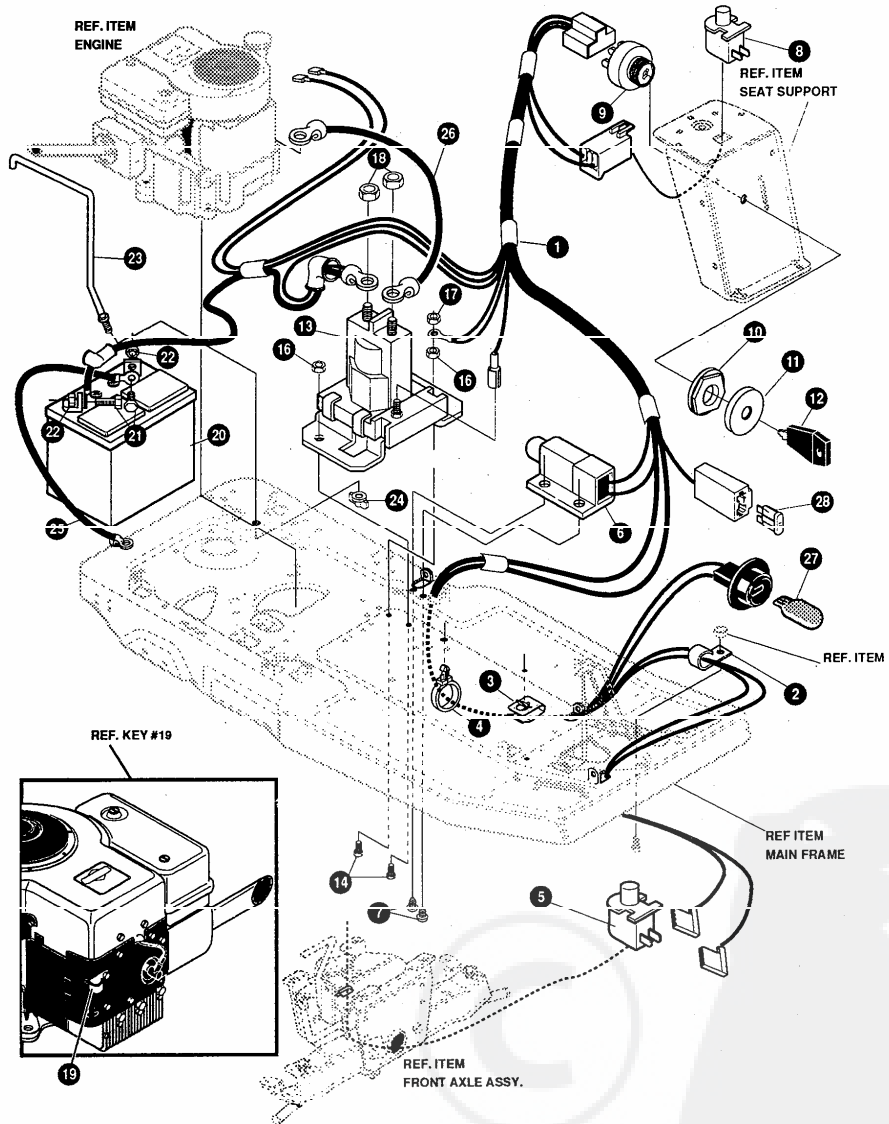

NOTE: ALWAYS USE ORIGINAL EQUIPMENT PARTS. Use of service/replacement parts other than original equipment parts may void your warranty.

ALL UNNUMBERED ITEMS ARE INTERCHANGEABLE WITH OPPOSITE SIDE

328294 A

E3595-080

ELECTRICAL ASSEMBLY

KEY#	PART#	DESCRIPTION	QTY
1	328287	HARNES, STD, RER C2 8-11B&S	1
2	57569	RETAINER, .31IDX.62X.03 WIRE	1
3	309098	CLIP, TRW #C4490-022-27	1
4	309698	CLIP, WIRE ROUTING, SNAP-IN	1
5	326653	SWITCH,SNAPMNT NO .055/.116	1
6	5/4/6	SWITCH,SCR MNT DP NC NO BLK	1
7	57220	SCREW, #12 X .50 PHPNHTAP BLK	2
8	326654	SWITCH, SNAP MNT NC .140 BLUE	1
9	327354	SWITCH,IGNITION & LIGHTS DELTA	1
10	327352	NUT, 5/8-8ACME DELTA FOR BOOT	1
11	300194	BOOT, IGN SWITCH	1
12	327350	KEY,IGNITION SWITCH MLD.DELTA	1
13	53716	SOLENOID	1
14	187745	SCREW, 1/4-20X .75 HXSEMMA	2
16	1502	NUT, 1/4-20 REGHEXCTRLK	2
17	271172	NUT, 1/4-20 REGHEXKEPS	1
18	271187	NUT, 5/16-24 HKEPS	2
19	57569	RETAINER, .31IDX.62X.03 WIRE	1
20	302257	BATTERY 12V 7 PLATE	1
21	180020	SCREW, 1/4-20X .75 HHC	1
22	271172	NUT, 1/4-20 REGHEXKEPS	2
23	327784	SUPPORT BATTERY HOLDDOWN U-1	1
24	325232	NUT, WING 1/4-20 NYLON	1
25	55511	WIRE, GROUND, 12.5"	1
26	322698	WIRE, STARTER, RED, 8.5"	1
27	52572	BULB, HEADLAMP	1
28	302031	FUSE SPADE TYPE 32V 15A	1

WIRING SCHEMATIC

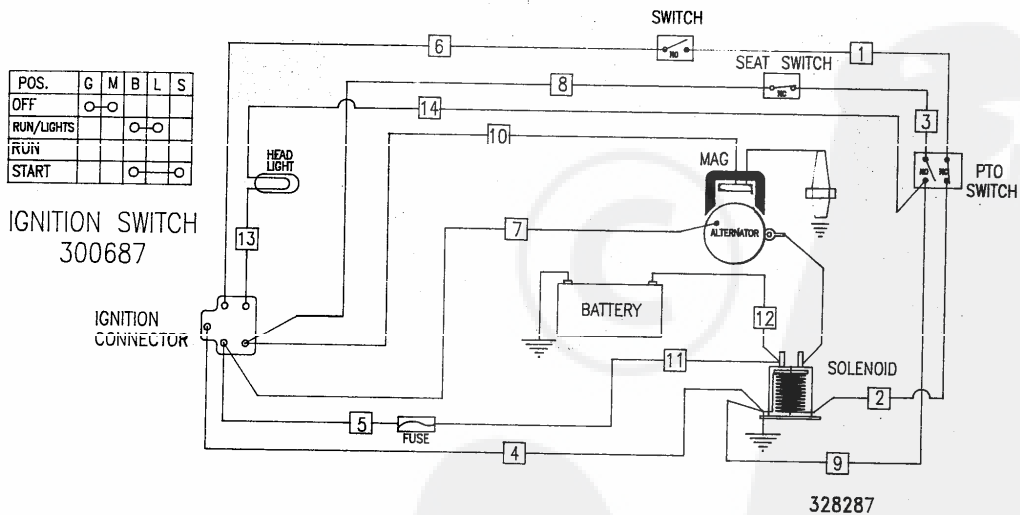

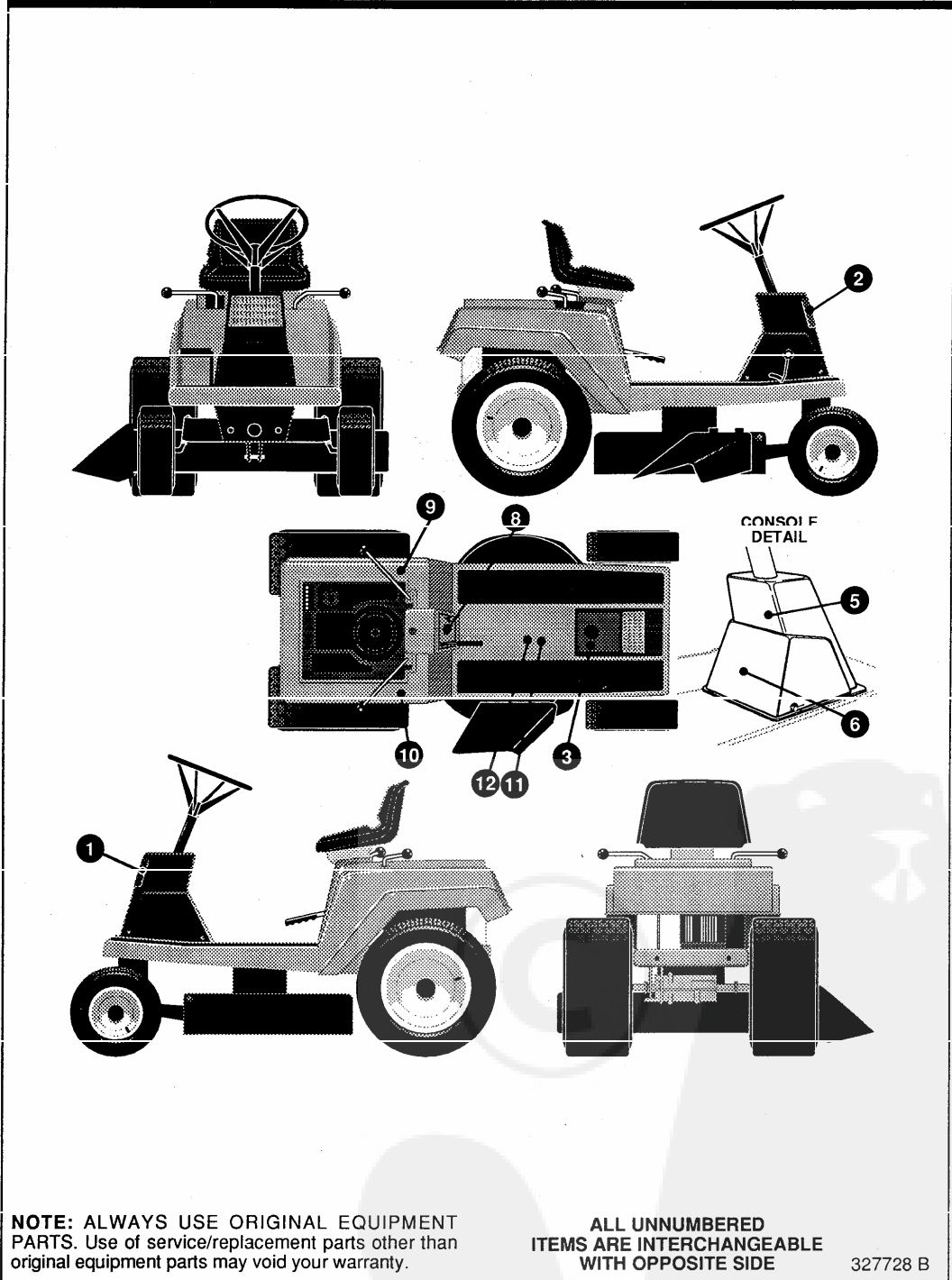

NOTE: ALWAYS USE ORIGINAL EQUIPMENT PARTS. Use of service/replacement parts other than original equipment parts may void your warranty.

ALL UNNUMBERED ITEMS ARE INTERCHANGEABLE WITH OPPOSITE SIDE

327728 B

E3595-080

DECAL ASSEMBLY

KEY#	PART#	DESCRIPTION	QTY
1	306557	DECAL, NOMA LENS, LH C-2 LITE.....	1
2	306558	DECAL, NOMA LENS, RH, C-2 LITE.....	1
3	317348	DECAL, PARK'N/BRAKE ISO.....	1
5	311227	DECAL, HEARING PROTECTION.....	1
6	327462	DECAL, INSTRUCTION EXPORT.....	1
8	320704	DECAL, CNTRL 30°, W/LITE.....	1
9	305307	DECAL, PTO ENGAGEMENT, ISO.....	1
10	311232	DECAL, SHIFT, 5SP, ISO, DOM.....	1
11	305770	DECAL, CAUTION TRIANGLE EUROPE.....	1
12	327461	DECAL, DECK WARN GR,FR,DU,&ITA.....	1

E3595-080

REPAIR PARTS

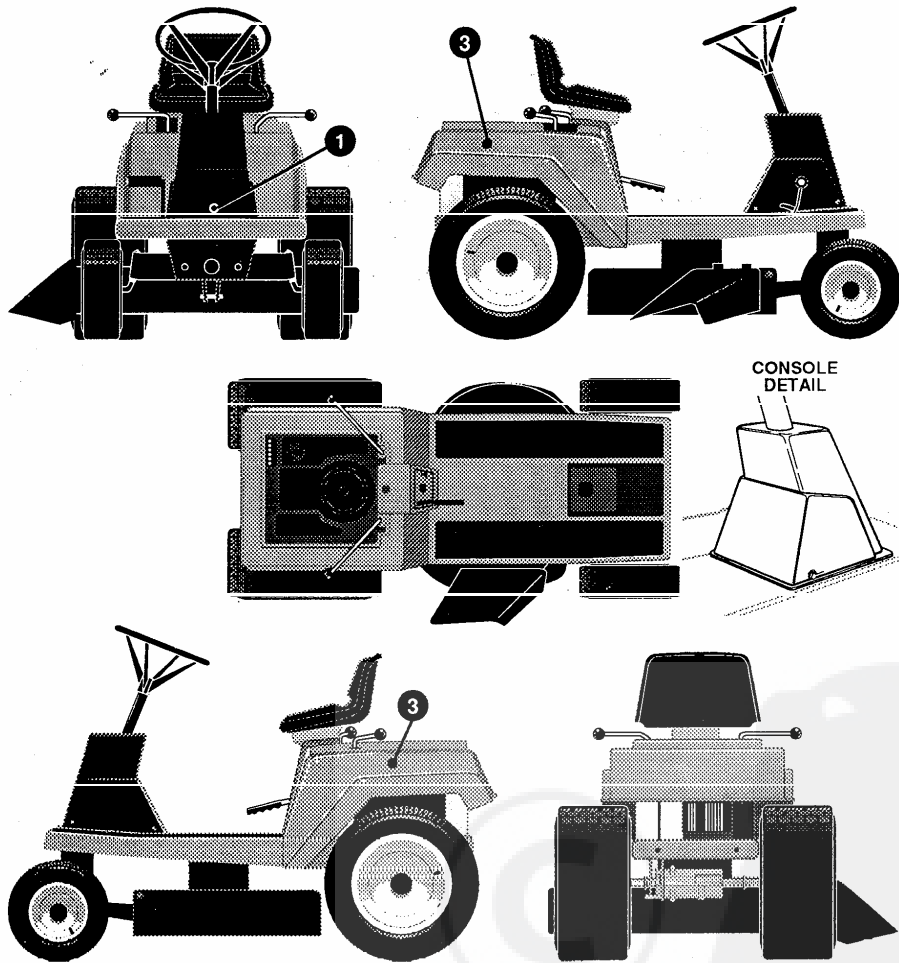

NOTE: ALWAYS USE ORIGINAL EQUIPMENT PARTS. Use of service/replacement parts other than original equipment parts may void your warranty.

ALL UNNUMBERED ITEMS ARE INTERCHANGEABLE WITH OPPOSITE SIDE

329022 B

E3595-080

DECAL ASSEMBLY

KEY#	PART#	DESCRIPTION	QTY
1	320799	NAME PLATE, 10.5/30 CHR/BLK.....	1
3	402142	NAMEPLATE, TURFMASTER WHT/BLK.....	2

E3595-080

REPAIR PARTS

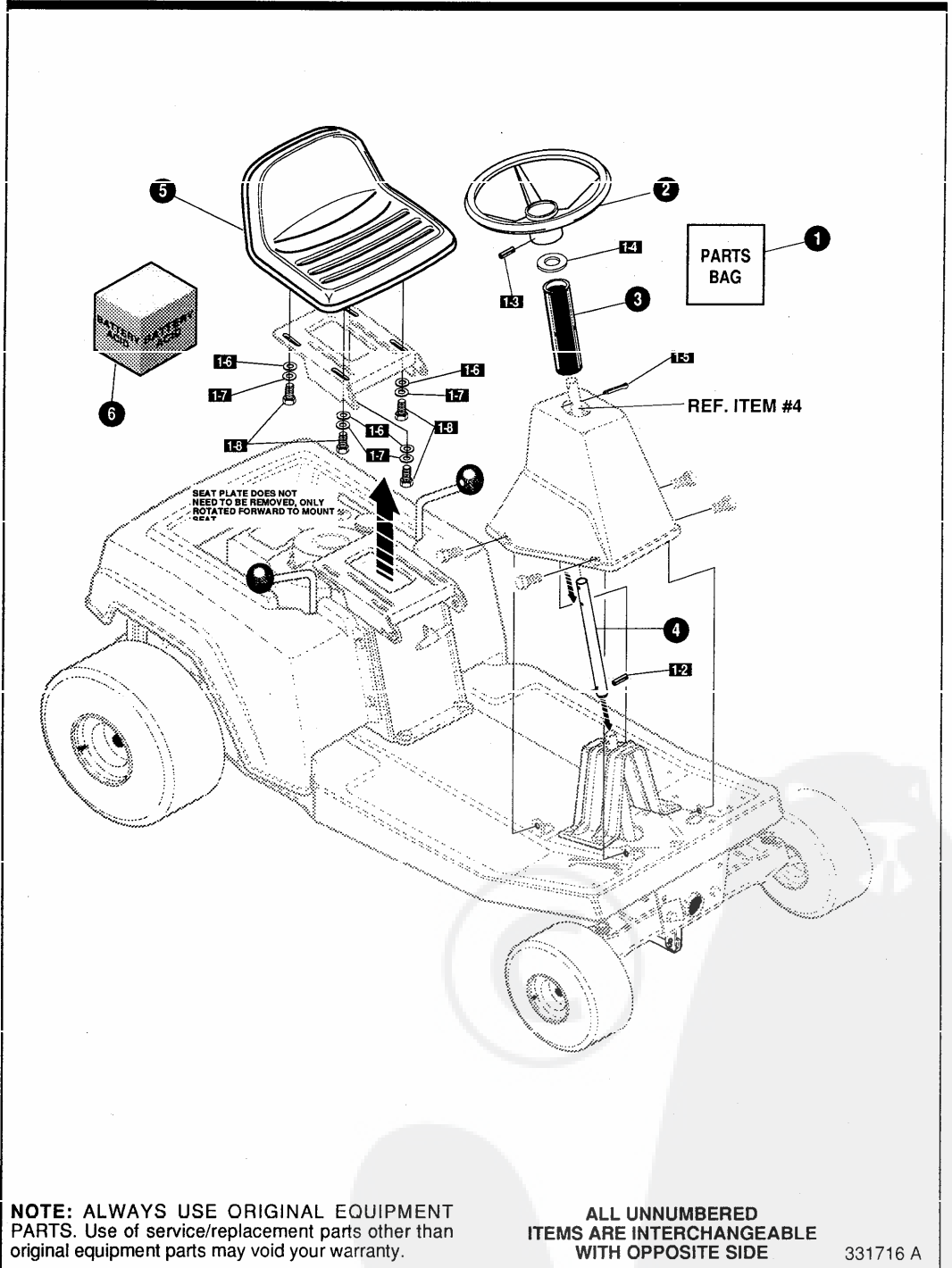

E3595-080

CUSTOMER ASSEMBLY

KEY#	PART#	DESCRIPTION	QTY
1		PARTS BAG RER.....	1
1-2	417375	PIN, SPRING.187DIA X1.25LG MD	1
1-3	456836	PIN, SPRING.250DIA X2.25LG	1
1-4	301702	WASHER, FLAT .90 X1.56X.089	1
1-5	120123	PIN, COTTER .125 DIA X1.25LG	1
1-6	120393	WASHER, FLAT .344X .69X.065	4
1-7	120638	WASHER, HVSP TLK .328X.60X.09	4
1-8	180077	SCREW, 5/16-18X .75 HHC	4
2	301465	STEERING WHEEL DEEP DISH	1
3	305605	TUBE-DCR TIVE,6.00"LG	1
4	300797	STEERING TUBE	1
5	304315	SEAT,MICH	1
6	^	BATTERY ACID PACK, 80 OZ.	1

^ CAN BE PURCHASED LOCALLY

TREAD PATTERNS

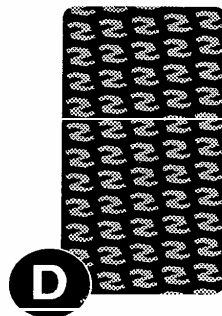
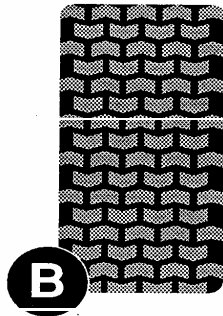
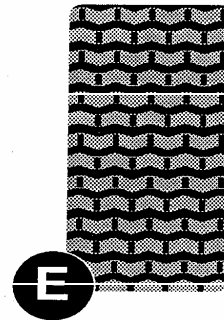
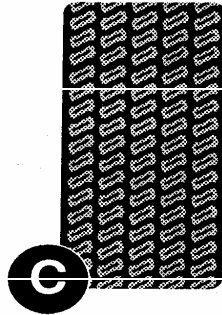
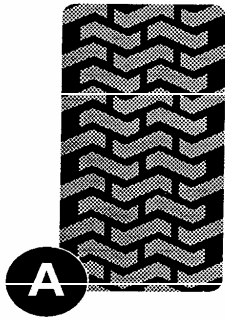

TIRE SIZE	"A"	"B"	"C"	"D"	"E"
11 X 4.00 - 5	42295	319679			
13 X 5.00 - 6	41060	319680			
15 X 6.00 - 6	39830	316702	301140	313952	
16 X 4.80 - 8		305035			
16 X 6.50 - 8	41081	319682		314539	
18 X 6.50 - 8		42091			
18 X 8.50 - 8	319683	317400			
18 X 9.50 - 8	41106	316701		313950	
20 X 8.00 - 8	319685	319684	57164	314584	331606
20 X 10.00 - 8	58276	319686		313654	
20 X 10.00 - 10	55893	319687			
23 X 9.50 - 12	53655	319690	319689	314370	

316711 D

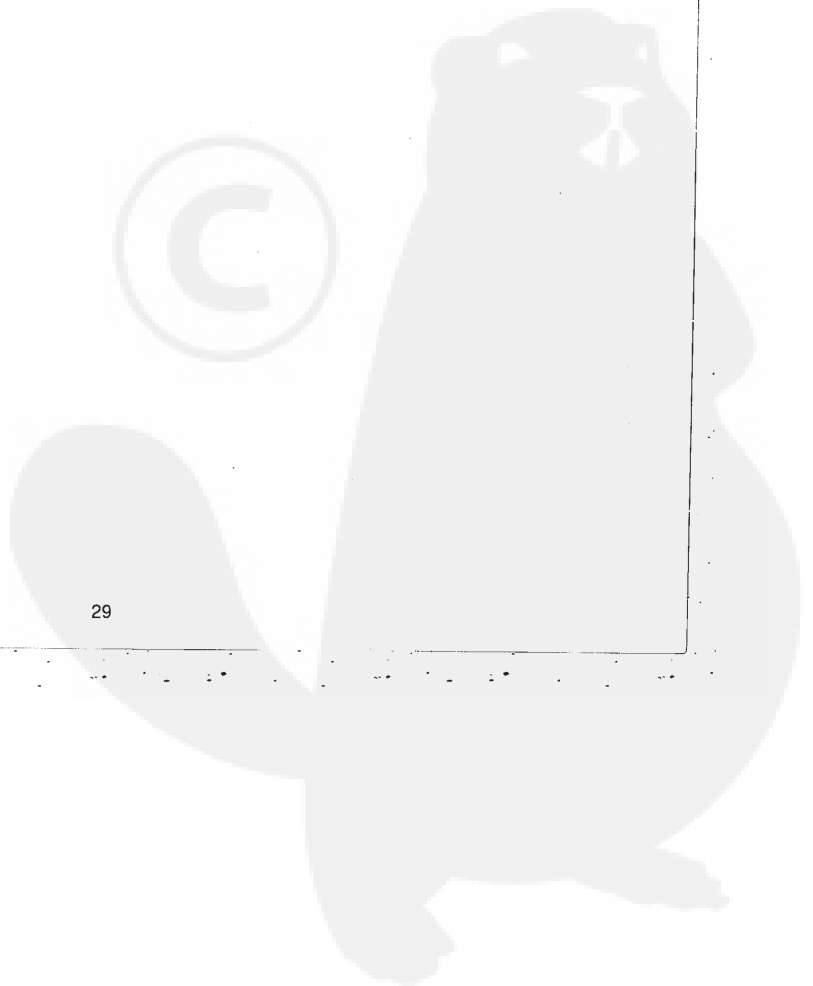
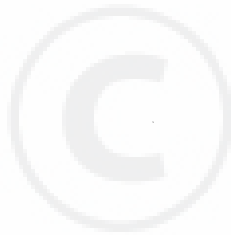

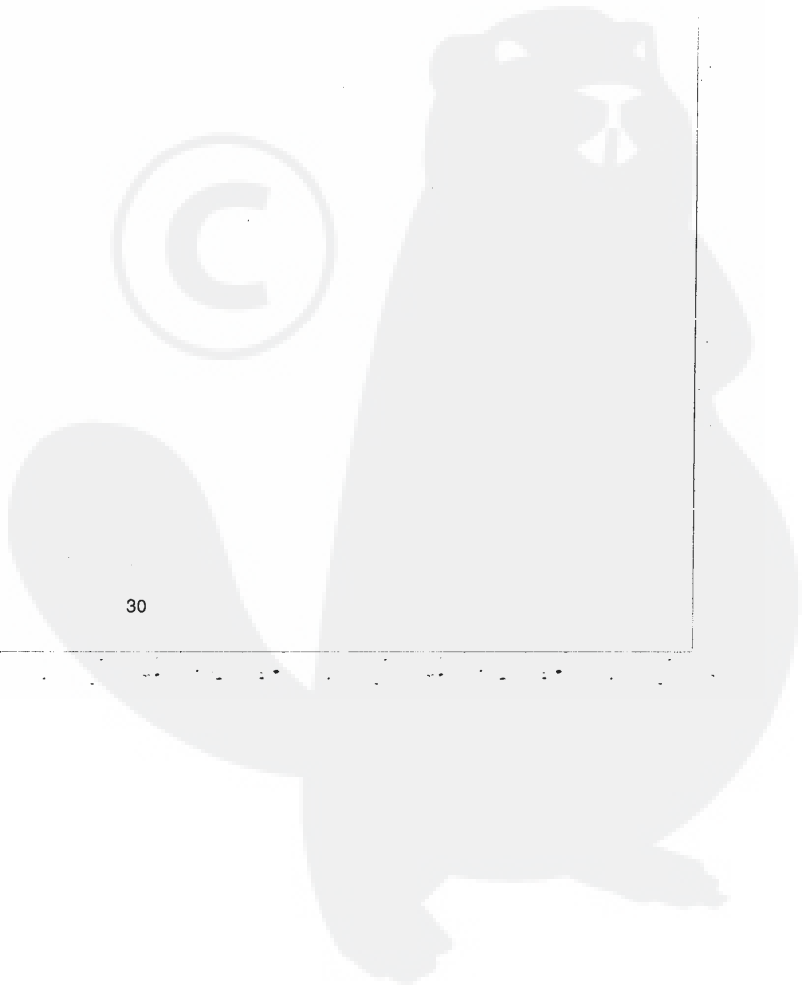
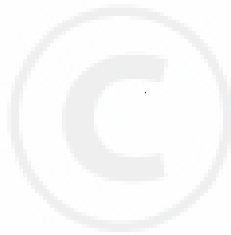

E3595-080

ACCESSORIES

Contact the dealer where your tractor was purchased for the available accessories. If you are unable to contact the dealer, write to the address on the front cover of this manual.

Rear Engine Rider

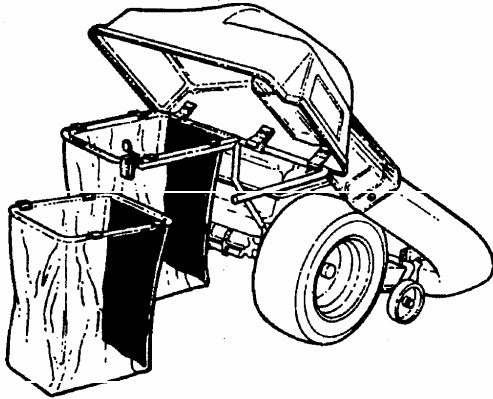

Model #5708-17
Grass Collector (30" decks)

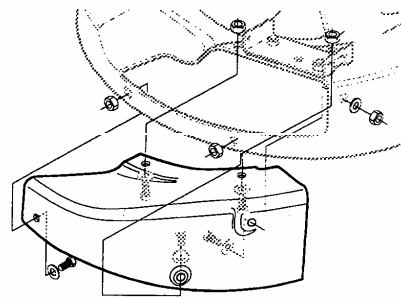

5714-00 Mulching Kit (30" Deck)

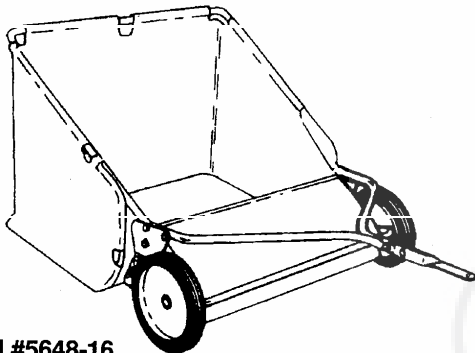

Model #5648-16
Tow Behind Lawn Sweeper for Grass and Leaves

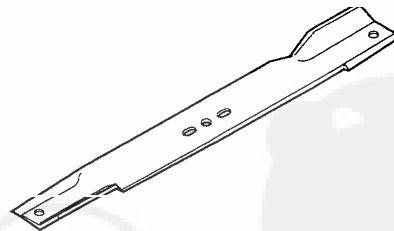

314275 -30" Standard Lift Blade

OTHER ACCESSORIES

Model	Description
5709 02	Front Weight Box - holds 35 lbs.
322397	30" Mulching blade

[The main body of the page contains extremely faint, illegible text that appears to be bleed-through from the reverse side of the paper. The text is too light to transcribe accurately.]

