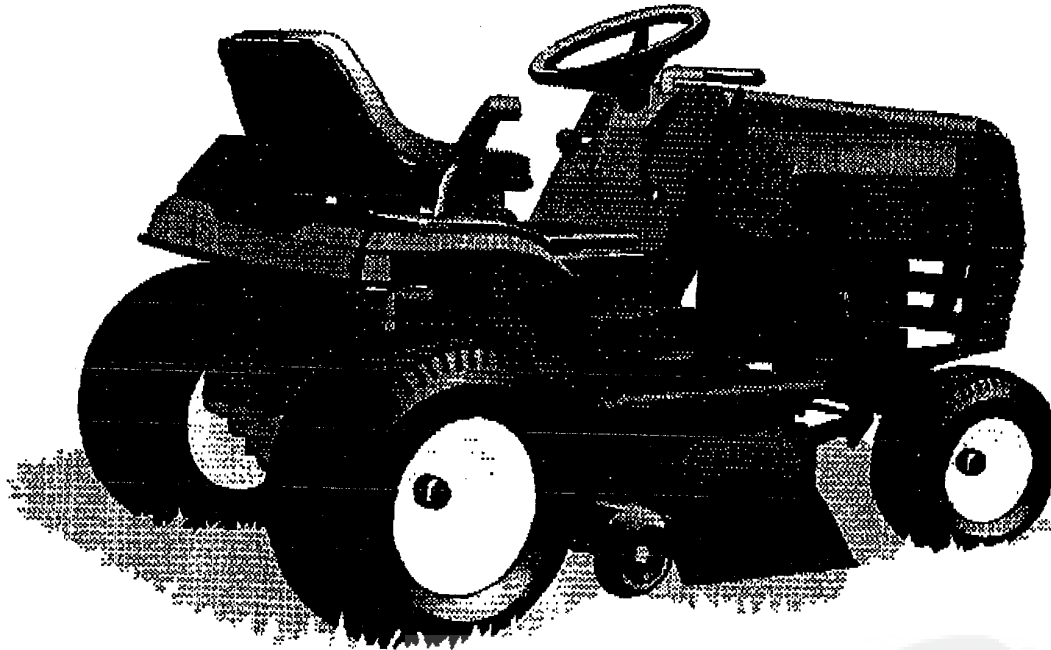

REPAIR**PARTS MANUAL****Model F3554-070****11HP/30" Deck****HOW TO ORDER REPAIR PARTS**

Only use a factory repair part. Repair parts, except for the engine or the transmission, are available from the store where the unit was purchased, a service shop recommended by the store, or an authorized service shop found in the yellow pages of the telephone directory.

If you cannot get a repair part or service as described above, call or write to the Central Parts Distributor shown on the back page of this manual or write: **Customer Service Department, Outdoor Power Equipment, PO Box 8000, Jackson, TN 38308, 1-800-247-7464.** Collect telephone calls will not be accepted. When you order, include the following information: 1- Complete Model Number (see nameplate), 2- Date of Manufacture, 3- Complete Part Number, 4- Description, and (5) Quantity.

Repair parts for the engine or the transmission are available from the manufacturer's authorized service center found in the yellow pages of the telephone directory. See the individual engine or transmission warranties.

- Read and keep this parts list book for future reference.
- This parts list book contains drawings and part numbers necessary to obtain repair parts.
- Record the following information about your unit. This information is necessary when ordering parts or in case of loss or theft.

WHERE PURCHASED: _____

DATE PURCHASED: Month _____ Day _____ Year _____

MODEL NO.: _____ DATE OF MANUFACTURE: _____

F3554-070

REPAIR PARTS

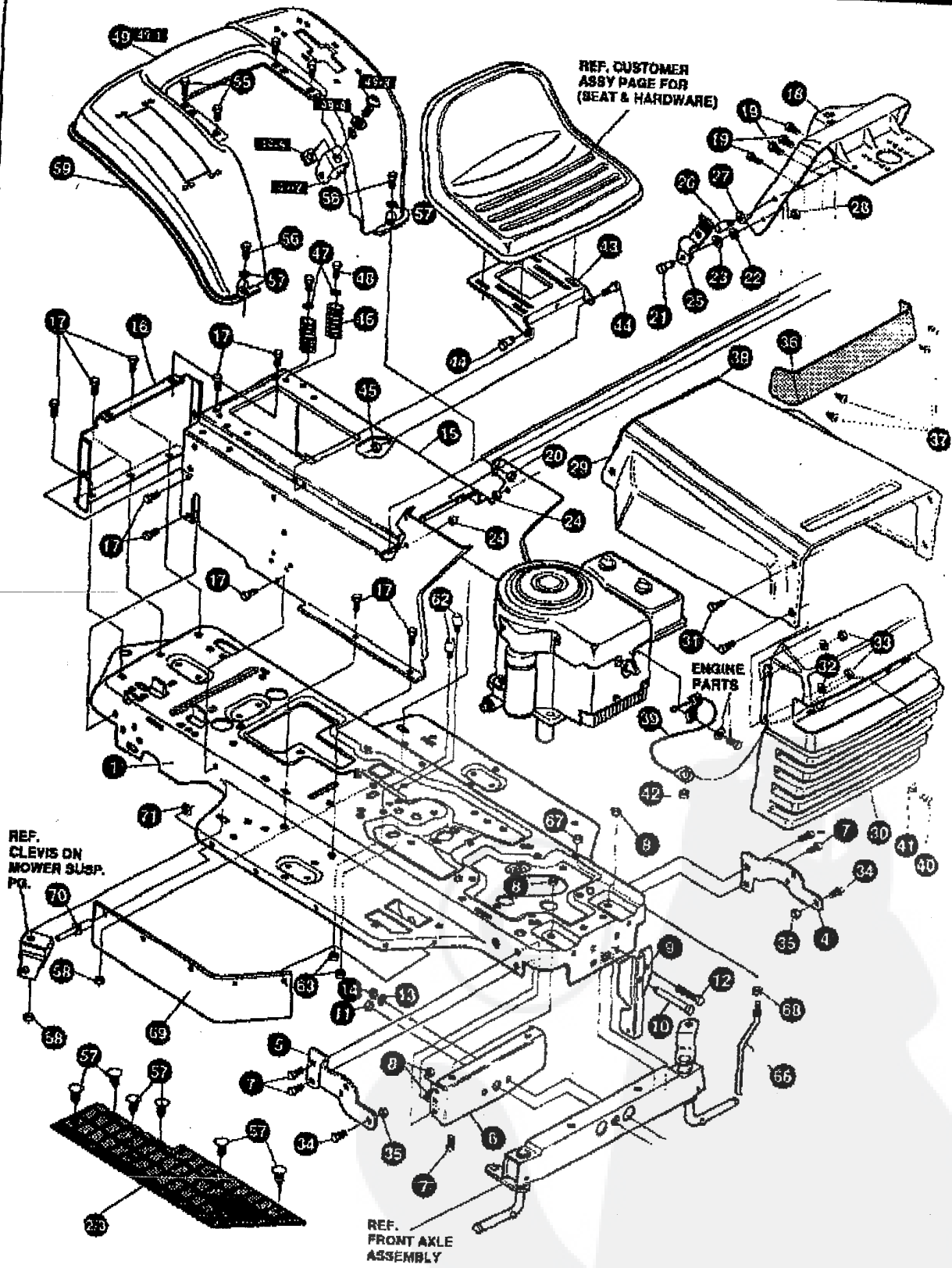

NOTE: ALWAYS USE ORIGINAL EQUIPMENT PARTS.
 Use of service/replacement parts other than original equipment parts may void your warranty.

ALL UNNUMBERED ITEMS ARE INTERCHANGEABLE WITH OPPOSITE SIDE

F3554-070

CHASSIS & HOOD ASSEMBLY

KEY#	PART#	DESCRIPTION	QTY
1	332319-830	MAIN FRAME, SF, RIDER, TUV	1
2	310004	FOOT PAD, RH, SF, MOLDED DYNA	1
3	310003	FOOT PAD, LH, SF, MOLDED DYNA	1
4	314579-853	BRACKET, GRILLE, LH, SF	1
5	314578-853	BRACKET, GRILLE, RH, SF	1
6	56362-853	BRACKET, SUPPORT, FRONT AXLE, SF	1
7	328154	SCREW, 5/16-18 X 1.0WDFLLK	6
8	55273	NUT, 5/16-18 WDFLLKLRG, WHIZ	6
9	321136-830	BRACKET, HANGER, 30°, SF	1
10	50720	BOLT, .825 X 2.875 SPSH, 1/2-20	1
11	274654	NUT, 1/2-20 REGHXCTRLK	1
12	180138	SCREW, 3/8-16 X 3.00 HHC	4
13	2483	WASHER, .39 ID X 1.25 D X .07 BELLVIL	4
14	1499	NUT, 3/8-16 REGHXCTRLK	4
15	324748-830	CONSOLE, SF, FENDER SHIFT	1
16	56235-830	CONSOLE, REAR COVER	1
17	995346	SCREW, 1/4-20 X .50 WAHHTAP	16
18	320466-830	DASH, SF, DYNA STYLING	1
19	44811	SCREW, 1/4-20 X .75 WAHHTAP	4
20	50352	NUT, 1/4-20 WDFLLK TOPLOCK	2
21	8482	BOLT, .375 X .156 HSH, 5/16-18	2
22	120394	WASHER, FLAT .406 X .81 X .065	2
23	120393	WASHER, FLAT .344 X .69 X .065	2
24	1498	NUT, 5/16-18 REGHEXCTRLK	2
25	57159	LATCH, .94 WD X .347, ASSEMBLY HOOD	2
26	53446	PIN, 5/16-18, HOOD LATCH	2
27	138538	WASHER, REGINTLK .320 X .61 X .03	2
28	45174	NUT, 5/16-18 HEXWDFLLK WHIZ	2
29	314538-860	HOOD, SF, H-21	1
30	325401	GRILLE, G17	1
31	274672	SCREW, 1/4-20 X .63 WAHHC	4
32	120392	WASHER, FLAT .281 X .63 X .065	4
33	1502	NUT, 1/4-20 REGHEXCTRLK	4
34	36149	BOLT, .375 X .500 HSH, 5/16-18	2
35	1498	NUT, 5/16-18 REGHEXCTRLK	2
36	362333	LENS, SMOKED W/TAB NO LOGO	1
37	57796	SCREW, #6 X .50 PLASTITE/HI-LO	4
38	52151	EDGING (78"-47453) WIDE BLACK	25.0'
39	311084	LANYARD, HOOD, 11.75 LONG, H15 VANG	1
40	180020	SCREW, 1/4-20 X .75 HHC	1
41	120392	WASHER, FLAT .281 X .63 X .065	1
42	1502	NUT, 1/4-20 REGHEXCTRLK	1
43	58367-830	PLATE, SEAT, F5, SF, LF	1
44	20507	BOLT, .437 X .156 HSH, 5/16-18	2
45	1498	NUT, 5/16-18 REGHEXCTRLK	2
46	330463	SPRING, SEAT 1.50 OD X 2.25 LONG	2
47	120392	WASHER, FLAT .281 X .63 X .065	2
48	995346	SCREW, 1/4-20 X .50 WAHHTAP	2
49	*	ASSEMBLY, FENDER, F-5, SF, SOF/LOF	1
49-1	332423-860	FENDER, F-5, SF, S.O.F/LOF	1
49-2	9239	CLEVIS	1
49-3	439455	SCREW, 5/16-18 X .58 PHPNMA	1
49-4	301551	WASHER, .344 ID X 1.50 D X .09 CU	1
49-5	120373	NUT, 5/16-18 SQUARE	1
55	995346	SCREW, 1/4-20 X .50 WAHHTAP	4
56	180081	SCREW, 5/16-18 X 1.25 HHC	2
57	309235	FASTENER, RATCHET, BLACK	12
57	446363	WASHER, FLAT .375 X .88 X .082	2
58	55273	NUT, 5/16-18 WDFLLKLRG, WHIZ	2
59	55023	TRIM, STRIP, BLACK—SMALL, W/ ADH	77.5'
62	53446	PIN, 5/16-18 HOOD LATCH	2
63	271184	NUT, 5/16-18 HEXKEPS	2
66	50653	GUIDE, BELT	1
67	41529	NUT, 3/8-16 HXCTRLKJAM	1
68	271190	NUT, 3/8-16 HEXKEPS	1
69	305395	BELT GUARD, SF, RUBBER, 7 X 25.46	2
70	329238	RIVET, POP 3/16 DIA X .75 LONG	12
71	1501	WASHER, FLAT .203 X .56 X .040	12
	336394	PARTS MANUAL	1
	336421	OPERATOR'S MANUAL (ENGLISH)	1
	336422	OPERATOR'S MANUAL (FRENCH)	1
	336423	OPERATOR'S MANUAL (GERMAN)	1
	323000	GRASS CATCHER MANUAL (ENGLISH)	1
	323208	GRASS CATCHER MANUAL (FRENCH)	1
	323207	GRASS CATCHER MANUAL (GERMAN)	1

* ORDER INDIVIDUAL PARTS - ASSEMBLY NOT AVAILABLE

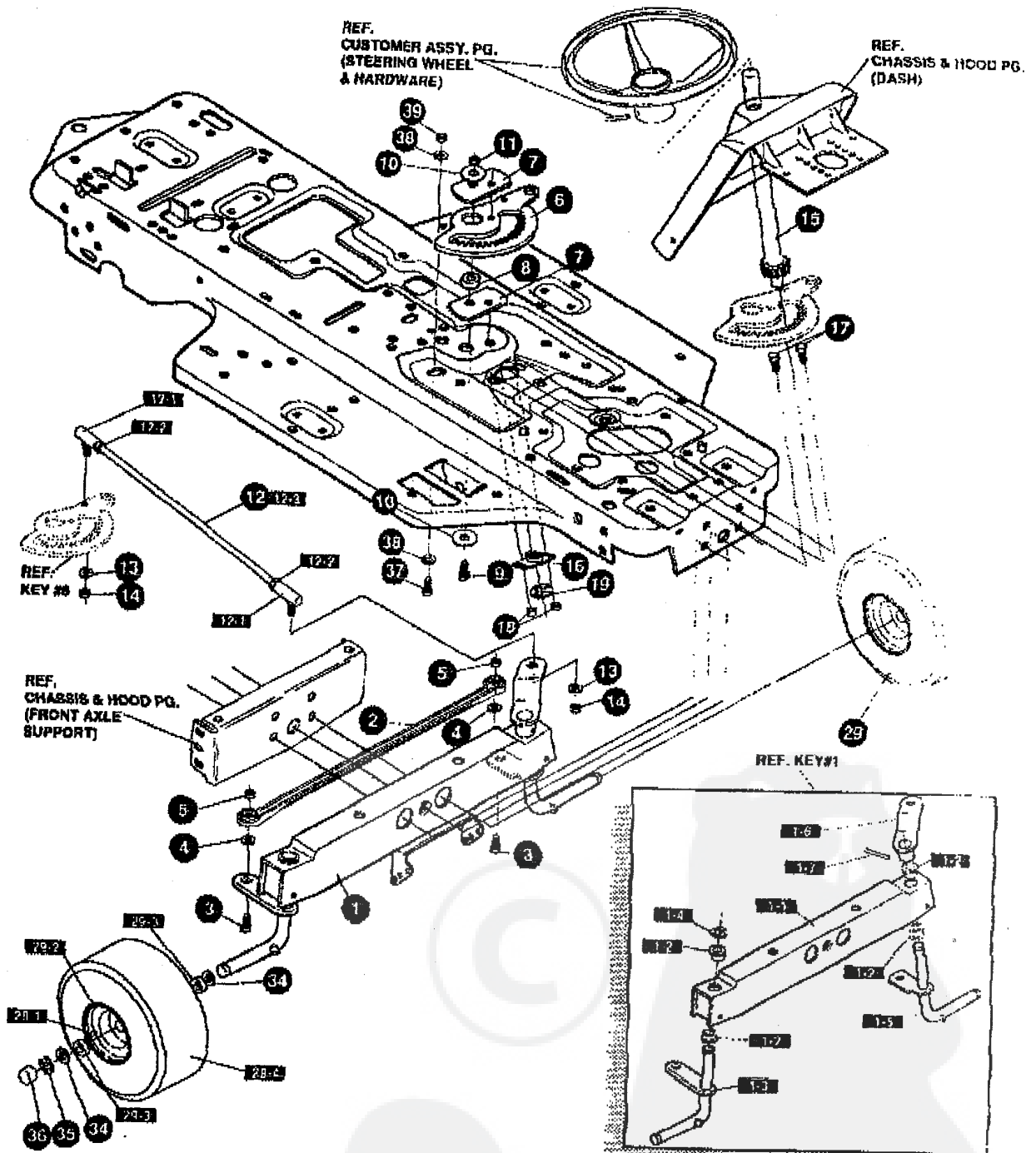
F3554-070**REPAIR PARTS**

NOTE: ALWAYS USE ORIGINAL EQUIPMENT PARTS.
Use of service/replacement parts other than original equipment parts may void your warranty.

**ALL UNNUMBERED
ITEMS ARE INTERCHANGEABLE
WITH OPPOSITE SIDE**

326426 11

F3554-070**STEERING ASSEMBLY**

KEY#	PART#	DESCRIPTION	QTY
1	*	AXLE FRONT ASSEMBLY, SF, LONG	1
1-1	312280	FRONT AXLE, ASSEMBLY, SF, BLACK	1
1-2	50546	BEARING, FLANGE .759 ID X 1.002 OD X .75	4
1-3	310368	SPINDLE, ASSEMBLY, RH, LONG, SF	1
1-4	36625	RING, RETEX .57 X .05 TRU 5133-75	1
1-5	310367	SPINDLE, ASSEMBLY, LH, LONG, SF	1
1-6	327819	ARM ASSEMBLY, SF, 4WS, FRONT STEERING	1
1-7	454565	PIN, SPRING .250 DIA X 1.25 LONG	1
2	302688	ASSEMBLY, TIE ROD, 19.31 LONG	1
3	180124	SCREW, 3/8-16 X 1.25 HHC	2
4	120382	WASHER, REGSPTLK .393 X .68 X .10	2
5	1499	NUT, 3/8-16 REGHXCTRLK	2
6	327399	GEAR, SECTOR SF, 2WS	1
7	333289	PLATE, SECTOR, SF, 4WS, BLACK	2
8	330021	BUSHING, SECTOR, GEAR, SF, 4WS	1
9	181643	SCREW, 3/8-24 X 1.50 HHC	1
10	845	WASHER, FLAT .390 X 1.25 X .119	2
11	412349	NUT, 3/8-24 HXCTRLK	1
12	328808	DRAG LINK ASSEMBLY, 17.69 LONG	1
12-1	57158	BALL JOINT, 3/8 THD, SHORT STUD	2
12-2	124925	NUT, 3/8-24 REGHEXJAM	2
12-3	56190	DRAG LINK	1
13	120382	WASHER, REGSPTLK .393 X .68 X .10	2
14	120369	NUT, 3/8-24 REGHEX	2
15	327834	SHAFT, PIN-STEER, BLACK	1
16	325882	BEARING, FLANGE .60 ID X 1.370 OD	1
17	326505	SCREW, 1/4-20 X .75 (TO 30-35 FT#)	2
18	46931	NUT, 1/4-20 WDFL MAC-LOCK	2
19	20864	RING, RET E .39 X .04 TRU 5133-50	1
29	*	TIRE & RIM, PU 13 X 5.0 X 6	2
29-1	24167	VALVE STEM	1
29-2	39937	RIM, WHEEL	1
29-3	314416	BEARING, FLANGE	1
29-4	TIRE	REFER TO TIRE TREAD PAGE	1
34	642	WASHER, FLAT .755 X 1.31 X .075	4
35	36625	RING, RETEX .57 X .05 TRU 5133-75	2
36	40394	HUB CAP, 1.500 ID X 7/8 LONG	2
37	180124	SCREW, 3/8-16 X 1.25 HHC	1
38	120394	WASHER, FLAT .406 X .81 X .065	2
39	45171	NUT, 3/8-16 HWDFL WHIZ-LOCK	1

* ORDER INDIVIDUAL PARTS - ASSEMBLY NOT AVAILABLE

F3554-070

REPAIR PARTS

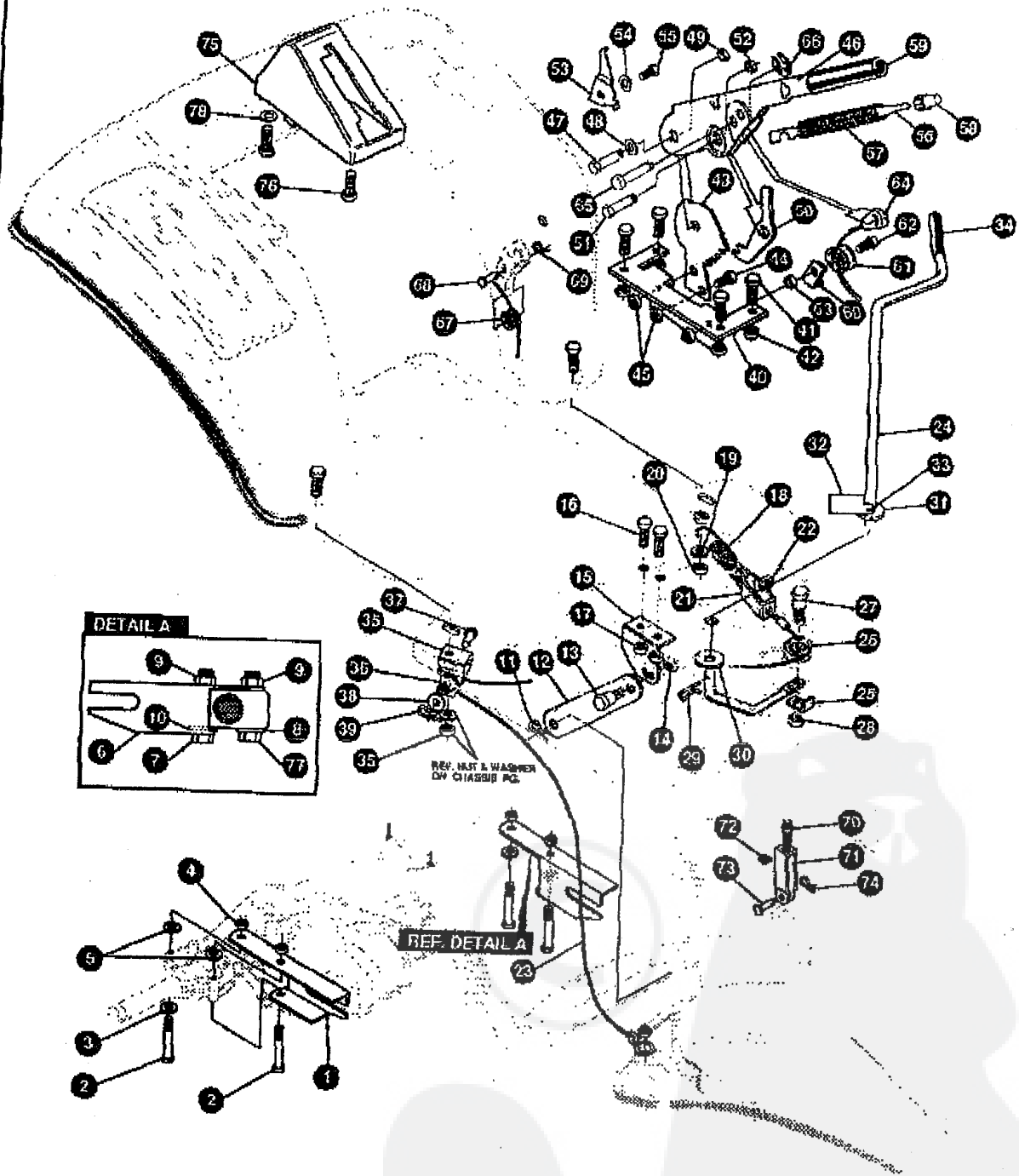

NOTE: ALWAYS USE ORIGINAL EQUIPMENT PARTS.
 Use of service/replacement parts other than original
 equipment parts may void your warranty.

**ALL UNNUMBERED
 ITEMS ARE INTERCHANGEABLE
 WITH OPPOSITE SIDE**

F3554-070**MOWER SUSPENSION ASSEMBLY**

KEY#	PART#	DESCRIPTION	QTY
1	321371	BRACKET, REAR SUPPORT, RH	1
2	180113	SCREW, 5/16-18 X 3.00 HHC	2
3	120393	WASHER, FLAT .344 X .69 X .065	1
4	1498	NUT, 5/16-18 REGHEXCTRLK	2
5	314702	SPACER, SLEEVE .344 X 1.00 X .500	2
6	321370	BRACKET, REAR SUPPORT, LH	1
7	180113	SCREW, 5/16-18 X 3.00 HHC	1
8	120393	WASHER, FLAT .344 X .69 X .065	1
9	1498	NUT, 5/16-18 REGHEXCTRLK	2
10	314702	SPACER, SLEEVE .344 X 1.00 X .500	1
11	56180	PIN, HAIR .091 DIA X 1.62 LONG	1
12	323899	BRACKET, LINK, LOWER, BLACK	1
13	313560	BOLT, .500 X .226 HSSH, 5/16-18	1
14	1498	NUT, 5/16-18 REGHEXCTRLK	1
15	320605	BRACKET, LIFT, BAR, 30" SF	1
16	180077	SCREW, 5/16-18 X .75 HHC	2
17	1498	NUT, 5/16-18 REGHEXCTRLK	2
18	300473	SPRING, TENSION 7.52 LONG+17 LB/IN	1
19	418924	WASHER, FLAT .344 X 1.13 X .082	1
20	1498	NUT, 5/16-18 REGHEXCTRLK	1
21	9405	CLEVIS, LIFT CABLE	1
22	120372	NUT, 1/4-20 REGSQ	1
23	322261	CABLE, CLUTCH, 31.31 LONG, (30"SF)	1
24	314877	LEVER, CLUTCH, SF, 30", SUS	1
25	1288	BRACKET, CABLE RETAINER	1
26	48306	PULLEY, METAL	1
27	58336	BOLT, .375 X .375 HSSH, 1/4-20	1
28	1502	NUT, 1/4-20 REGHEXCTRLK	1
29	8260	PIN, HAIR .091 DIA X 1.66 LONG	1
30	996425	WASHER, FLAT .515 X .88 X .064	1
31	22265	WASHER, FLAT .515 X 1.38 X .119	1
32	305225	STOP, PTO ENGAGE	1
33	326386	PIN, SPRING .187 DIA X 1.13 LONG	1
34	331624	KNOB, ROUND 1.50 DIA OR GRIP, SF	1
35	321295-853	CLEVIS, PTO PULLY	1
36	48306	PULLEY, METAL	1
37	300317	PIN, CLEVIS .375 DIA X .81 LONG	1
38	996416	WASHER, FLAT .391 X 1.00 X .125	1
39	8260	PIN, HAIR .091 DIA X 1.66 LONG	1
40	313926	BRACKET, HEIGHT ADJUST	1
41	180077	SCREW, 5/16-18 X .75 HHC	4
42	1498	NUT, 5/16-18 REGHEXCTRLK	4
43	301238	QUADRANT, HEIGHT ADJUST	1
44	180077	SCREW, 5/16-18 X .75 HHC	2
45	1498	NUT, 5/16-18 REGHEXCTRLK	2
46	322292-853	HANDLE, LIFT SHORT (30" S.F.)	1
47	300171	BOLT, .500 X .270 HSSH, 5/16-18	1
48	996418	WASHER, FLAT .506 X .75 X .024	1
49	44108	NUT, 5/16-18 HWDFLCTRLK	1
50	301239	PAWL, SQUARE	1
51	300171	BOLT, .500 X .270 HSSH, 5/16-18	1
52	44108	NUT, 5/16-18 HWDFLCTRLK	1
53	9435	POINTER, HEIGHT ADJUST	1
54	138479	WASHER, EXLK .195 X .41 X .03	1
55	35287	SCREW, #6-32 X .38 HHWATAP	1
56	303027	ROD, ACTUATOR-SHORT	1
57	58326	SPRING, HEIGHT ADJUST	1
58	58325	KNOB, HEIGHT ADJUST, PUSH BUTTON	1
59	58329	GRIP, .750 OD W/ HOLE BLACK	1
60	9149	BRACKET, CABLE RETAINER	1
61	48306	PULLEY, METAL	1
62	58336	BOLT, .375 X .375 HSSH, 1/4-20	1
63	1502	NUT, 1/4-20 REGHEXCTRLK	1
64	321430	CABLE, LIFT, 21.50 - 30" SF	1
65	300310	PIN, CLEVIS .310 DIA+ .475 LONG	1
66	300311	RING, RET E .31 X .25 TRU 5133-31	1
67	48306	PULLEY, METAL	1
68	300317	PIN, CLEVIS .375 DIA X .81 LONG	1
69	8260	PIN, HAIR .091 DIA X 1.66 LONG	1
70	120375	NUT, 1/4-20 REGHEX	1
71	9405	CLEVIS, LIFT CABLE	1
72	120372	NUT, 1/4-20 REGSQ	1
73	39522	PIN, CLEVIS .312 X .812	1
74	121222	PIN, COTTER .090 DIA X .75 LONG	1
75	300335	LIFT COVER, 39", F5	1
76	300340	SCREW, #10 X .75 HHPLAST, BLACK	3
77	180091	SCREW, 5/16-18 X 2.50 HHC	1
78	120392	WASHER, FLAT .281 X .53 X .065	1

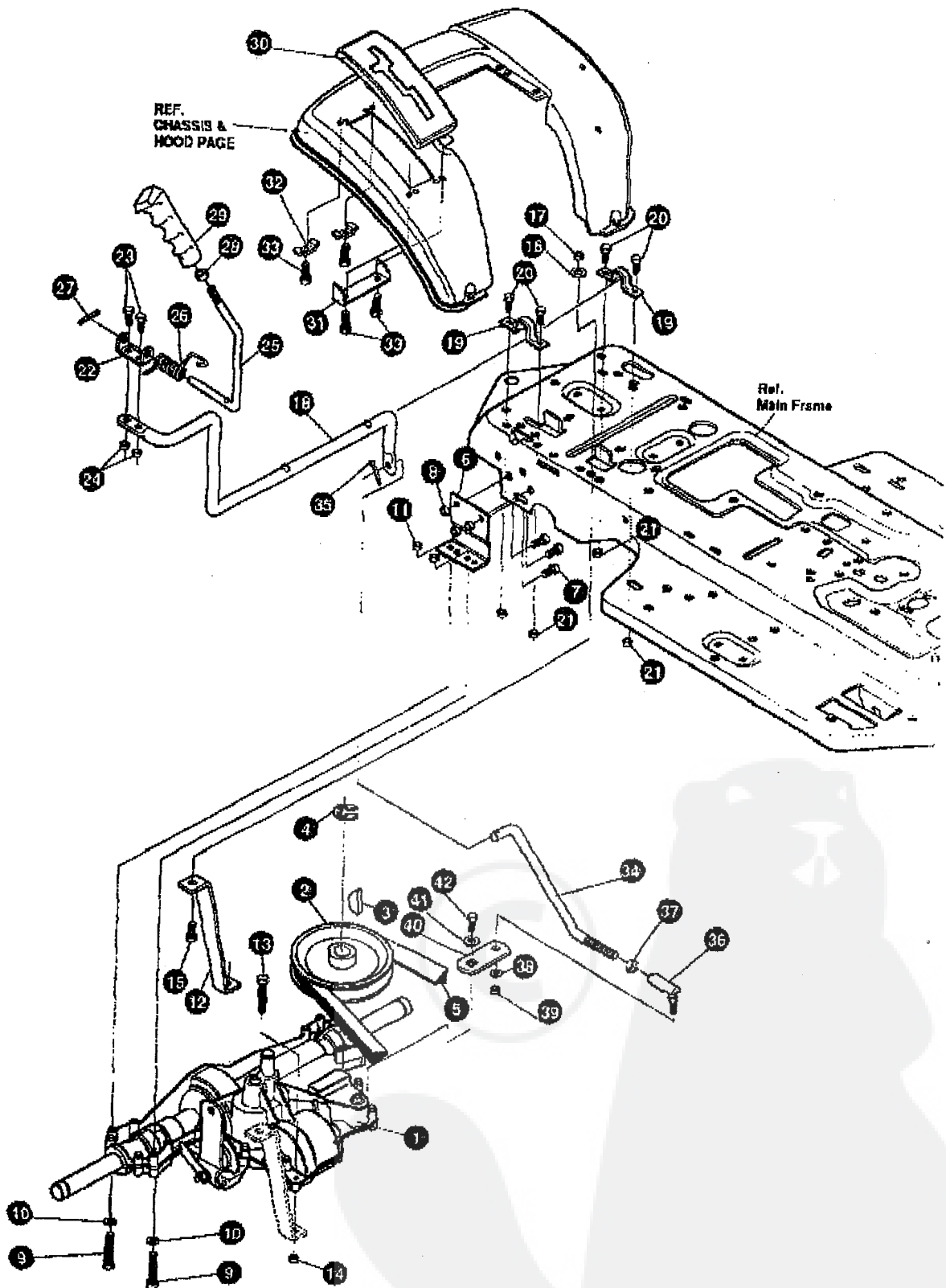
F3554-070**REPAIR PARTS**

NOTE: ALWAYS USE ORIGINAL EQUIPMENT PARTS.
Use of service/replacement parts other than original equipment parts may void your warranty.

**ALL UNNUMBERED
ITEMS ARE INTERCHANGEABLE
WITH OPPOSITE SIDE**

333359 A

F3554-070**MOTION DRIVE ASSEMBLY**

KEY#	PART#	DESCRIPTION	QTY
1	*	TRANSAXLE, 940-007, 2WS, LF, SF	1
2	303109	PULLEY, 6.6 OD, V4L, T/A	1
3	50795	KEY, HI-PRO 606 .75 DIA X .187 WD	1
4	22053	RING, RETEX .58 X .035 TRU 5100-82	1
5	54758	BELT, V 4L, 82.00, SF, DRIVE	1
6	53768-853	BRACKET, TRANSAXLE	2
7	160077	SCREW, 5/16-18 X .75 HHC	6
8	1498	NUT, 5/16-18 REGHEXCTRLK	6
9	180091	SCREW, 5/16-18 X 2.50 HHC	4
10	120393	WASHER, FLAT .344 X .68 X .065	4
11	1498	NUT, 5/16-18 REGHEXCTRLK	4
12	923213	BRACKET, T/A TORQ. BLACK	1
13	180087	SCREW, 5/16-18 X 2.00 HHC	1
14	1498	NUT, 5/16-18 REGHEXCTRLK	1
15	180079	SCREW, 5/16-18 X 1.00 HHC	1
16	138485	WASHER, EXLK .320 X .61 X .03	1
17	1498	NUT, 5/16-18 REGHEXCTRLK	1
18	321849	LEVER, SHIFT LOWER, SF, FENDER SHIFT, 915	1
19	302760	CLAMP, .625 DIA	2
20	180077	SCREW, 5/16-18 X .75 HHC	4
21	1498	NUT, 5/16-18 REGHEXCTRLK	4
22	310356	BRACKET, PIVOT SHIFT LEVER	1
23	180020	SCREW, 1/4-20 X .75 HHC	2
24	1502	NUT, 1/4-20 REGHEXCTRLK	2
25	324798	LEVER, SHIFT, UPPER, SOF, 1/2-13	1
26	310285	SPRING, TORSION .56 X .85 X .095	1
27	137185	PIN, COTTER .125 DIA X 1.00 LONG	1
28	120238	NUT, 1/2-13 HEXJAM	1
29	304729	KNOB, ROUND 1.50 DIA OR GRIP, SF	1
30	311209	COVER, PLASTIC, LF, P930/F4360-6	1
31	311257-853	BRACKET, COVER, F-5, FENDER SHIFT	1
32	1341	CLAMP, SPRING 1.17"ID	2
33	311331	SCREW, 1/4-15 X .44/.53 HILOHWA	4
34	321844	ROD, CONNECTING, SHIFT	1
35	137185	PIN, COTTER .125 DIA X 1.00 LONG	1
36	57158	BALL JOINT, 3/8 THD, SHORT STUD	1
37	124925	NUT, 3/8-24 REGHEXJAM	1
38	120382	WASHER, REGSPTLK .393 X .68 X .10	1
39	120369	NUT, 3/8-24 REGHEX	1
40	323212	BRACKET, SHIFT, SF, BLACK	1
41	57157	WASHER, .750 X .250 SP-TRANSAXLE	1
42	56255	SCREW, 1/4-28 X .75 NYLHHC	1

* CONTACT YOUR NEAREST TRANSAXLE DEALER FOR PARTS & SERVICE

F3554-070

REPAIR PARTS

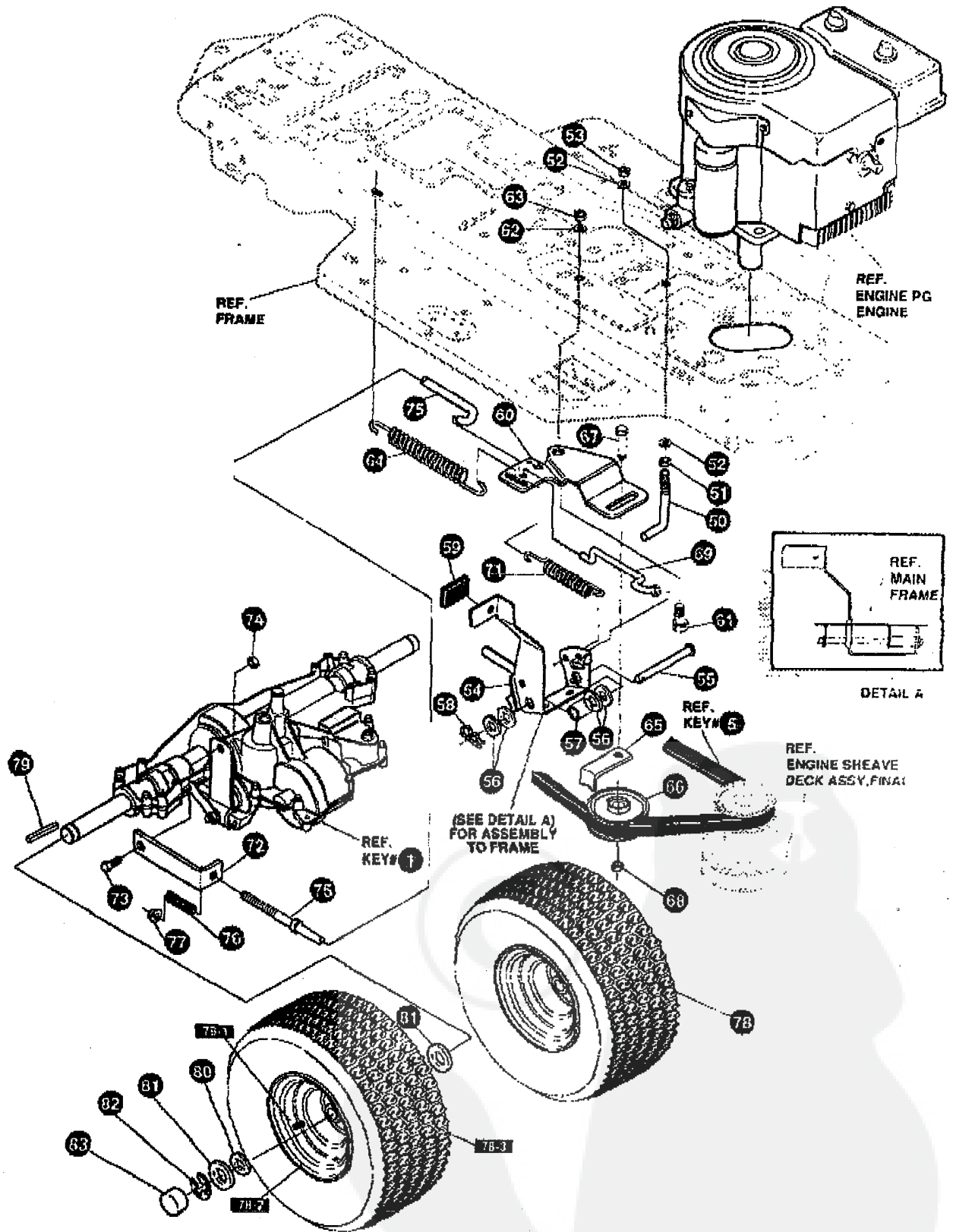

NOTE: ALWAYS USE ORIGINAL EQUIPMENT PARTS.
Use of service/replacement parts other than original equipment parts may void your warranty.

ALL UNNUMBERED ITEMS ARE INTERCHANGEABLE WITH OPPOSITE SIDE

333359 A

F3554-070**MOTION DRIVE ASSEMBLY**

KEY#	PART#	DESCRIPTION	QTY
50	49896	BELT GUIDE	1
51	271184	NUT, 5/16-18 HEXKEPS	1
52	120393	WASHER, FLAT .344 X .69 X .065	2
53	1498	NUT, 5/16-18 REGHEXCTRLK	1
54	331836	ASSEMBLY, PEDAL, BRAKE, CLUTCH, SF	1
55	319676	PIN, CLEVIS .500 D X 4.87 LONG	1
56	2968	WASHER, FLAT .504 X .75 X .059	4
57	331972	SPACER, SLEEVE .53 X .82 X 1.240	1
58	56180	PIN, HAIR, .091 DIA X 1.82 LONG	1
59	48761	PAD, CLUTCH/BRAKE PEDAL	1
60	321969	IDLER ARM BRACKET, TRACTION, SF	1
61	329989	BOLT, .625 X .195 HSSH, 5/16-18	1
62	45602	WASHER, FLAT .393 X .87 X .119	1
63	1498	NUT, 5/16-18 REGHEXCTRLK	1
64	327867	SPRING, 3/4 OD X 7.75 X .091 TENSION	1
65	39659	RETAINER, BELT	1
66	35374	PULLEY, IDLER, V4L, 3.06 X .62	1
67	45892	BOLT, 3/8-16 X 1.50 CARRSN	1
68	1499	NUT, 3/8-16 REGHXCTRLK	1
69	333175	CLUTCH ROD ASSEMBLY, .268 DIA 3.92	1
71	326780	SPRING, 3/8 OD X 2.18 X .055 TENSION	1
72	323210	BRACKET, TRACTION, SF, BLACK	1
73	46624	BOLT, .500 X .188 HSSH, 5/16-18	1
74	1498	NUT, 5/16-18 REGHEXCTRLK	1
75	333263	ROD, BRAKE 940, BLACK	1
76	313881	CLUTCH SPRING	1
77	50352	NUT, 1/4-20 WDFLLK, TOPLOCK	1
78	*	TIRE & RIM, PU 18 X 6.5 X 8	2
78-1	21467	VALVE STEM	
78-2	36182	RIM, WHEEL	
78-3	TIRE	REFER TO TIRE TREAD PAGE	
79	52928	KEY, SQUARE .187 SQUARE X 2.25 LONG	2
80	642	WASHER, FLAT .755 X 1.31 X .075	4
81	42815	WASHER, FLAT .755 X 1.53 X .07	2
82	36625	RING, RETEX .57 X .05 TRU 5133-75	2
83	40394	HUB CAP, 1.500 ID X 7/8 LONG	2

* ORDER INDIVIDUAL PARTS - ASSEMBLY NOT AVAILABLE

F3554-070

REPAIR PARTS

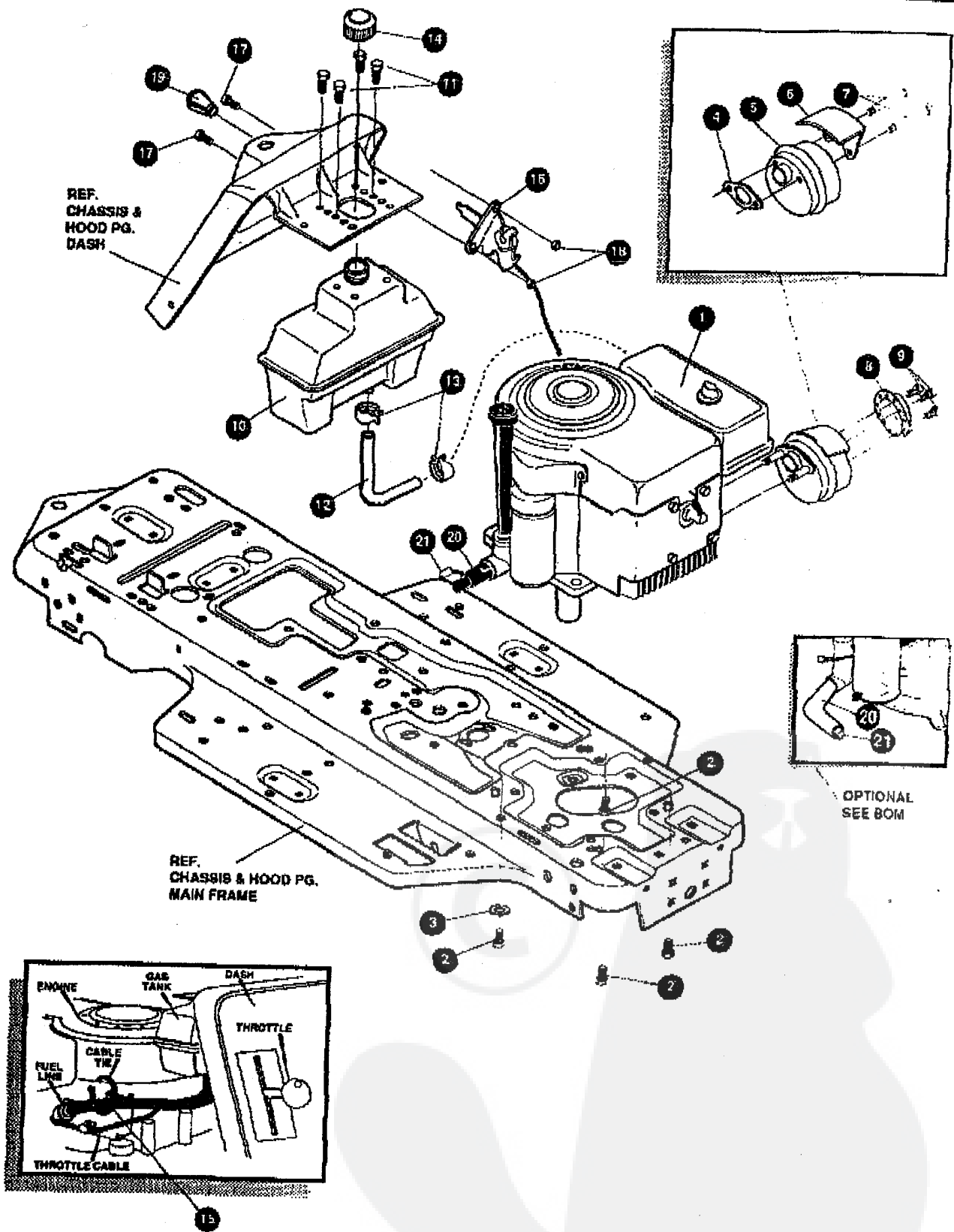

NOTE: ALWAYS USE ORIGINAL EQUIPMENT PARTS.
Use of service/replacement parts other than original equipment parts may void your warranty.

ALL UNNUMBERED ITEMS ARE INTERCHANGEABLE WITH OPPOSITE SIDE

F3554-070**ENGINE & CONTROL ASSEMBLY**

KEY#	PART#	DESCRIPTION	QTY
1	*	ENGINE, 10-12HP, B&B, 3A	1
2	50947	SCREW, 3/8-16 X 1.25 WAHTAPBLK	4
3	138489	WASHER, EXLK .384 X .69 X .04	1
4	46708	GASKET, MUFFLER	1
5	57908	MUFFLER-DOMESTIC/EXPORT ROUND	1
6	54767	SHIELD, HEAT, FOR ROUND MUFFLER	1
7	54980	SCREW, 5/16-18 X 3.50 HHC	2
8	323423	DEFLECTOR, MUFFLER PARTIAL	1
9	35287	SCREW, #8-32 X .38 HHWATAP	3
10	314989	TANK, FUEL 1 GALLON, CLEAR	1
11	300303	SCREW, .25 X .75 X .51 HHWA, PLASTITE	4
12	42258	TUBING, .25 X .50 X BULK GAS LINE	12 0'
13	47345	CLAMP, HOSE SCREW TYPE	2
14	46704	CAP, GAS 1-1/2-7 THD, BLACK	1
15	57444	TIE, CABLE BLACK NYLON, 5.62 LONG	1
16	320031	THROTTLE CONTROL	1
17	274707	SCREW, 10-24 X .50 WAHMA	2
18	308459	NUT, #10-24 HXHDNYLK	2
19	50607	KNOB, ROUND THROTTLE, BLACK	1
20	43989	OIL DRAIN VALVE OR TUBE	1
21	23700	CAP OR PLUG FOR OIL DRAIN	1

* SEE ENGINE MANUAL

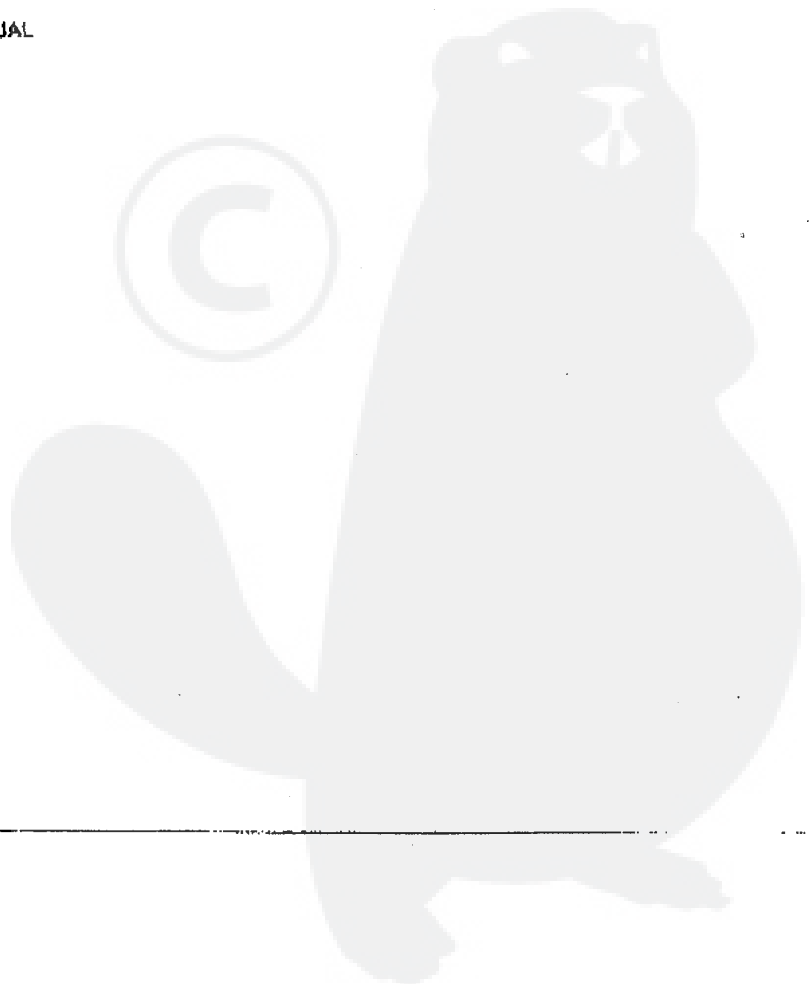
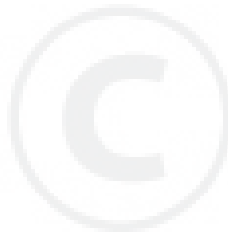

F3554-070

REPAIR PARTS

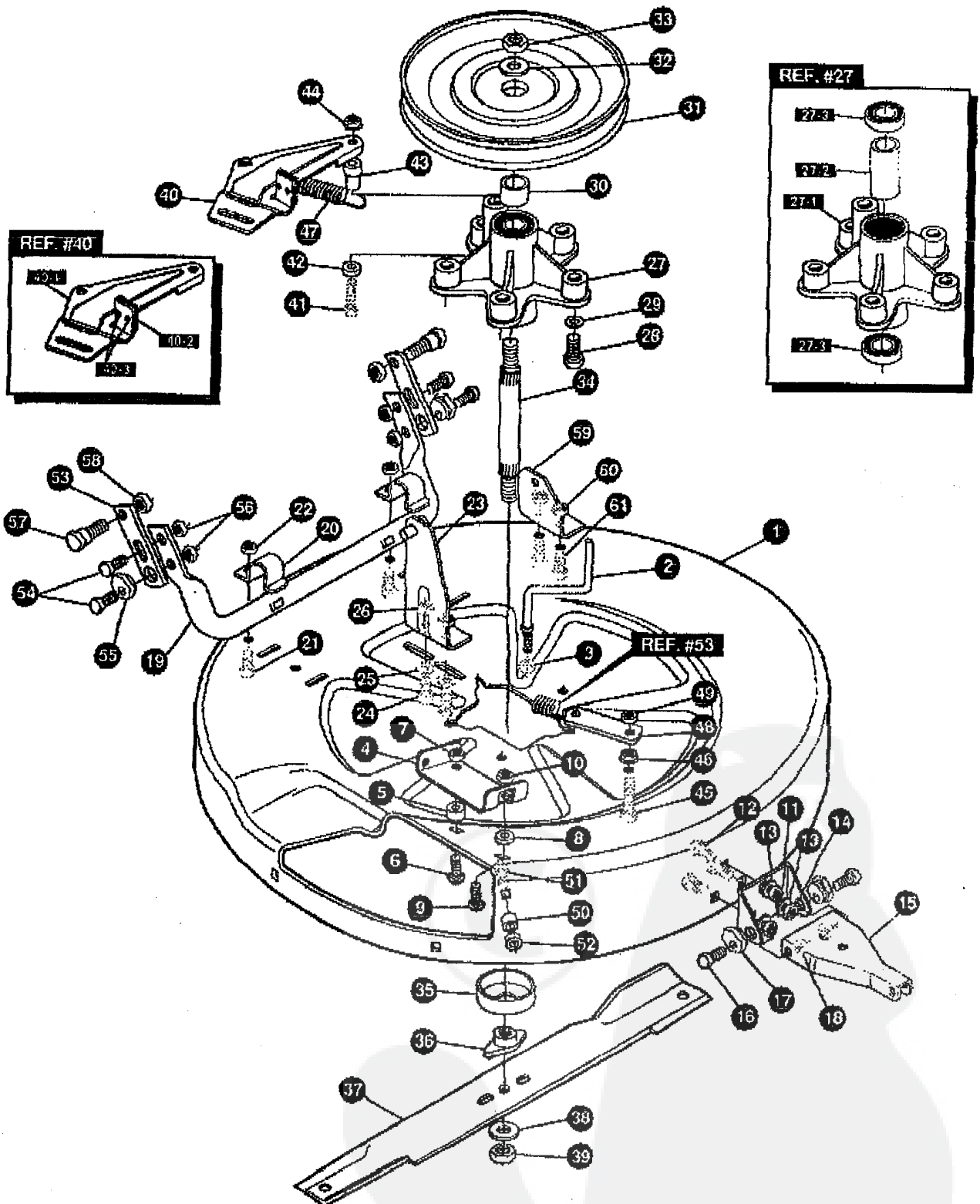

NOTE: ALWAYS USE ORIGINAL EQUIPMENT PARTS.
Use of service/replacement parts other than original equipment parts may void your warranty.

ALL UNNUMBERED ITEMS ARE INTERCHANGEABLE WITH OPPOSITE SIDE

F3554-070**PRE-PAINTED DECK ASSEMBLY**

KEY#	PART#	DESCRIPTION	QTY
1	321982	DECK MOWER, 30", SF, RER	1
2	57318	GUIDE, BELT 5/16-18 THD	1
3	1498	NUT, 5/16-18 REGHEXCTRLK	1
4	317017	BRACKET, CHUTE MOUNT, BLACK	1
5	314702	SPACER, SLEEVE .344 X 1.00 X .500	1
6	120230	BOLT, 5/16-18 X 1.25 CARRLN	1
7	1498	NUT, 5/16-18 REGHEXCTRLK	1
8	45602	WASHER, FLAT .333 X .87 X .119	1
9	126216	BOLT, 5/16-18 X .75 CARRLN	1
10	1498	NUT, 5/16-18 REGHEXCTRLK	1
11	311237	BRACKET, MOUNTING, FRONT	1
12	57072	BOLT, 5/16-18 X .63 CARRLN	3
13	120393	WASHER, FLAT .344 X .69 X .065	3
14	1498	NUT, 5/16-18 REGHEXCTRLK	3
15	311236	BRACKET, BAR, TOW, FRONT	1
16	180079	SCREW, 5/16-18 X 1.00 HHC	2
17	58247	NUT, ADJUST	2
18	1498	NUT, 5/16-18 REGHEXCTRLK	2
19	313372	ASSEMBLY, TUBE, PIVOT	1
20	310672	SUPPORT, PIVOT TUBE, BLACK	2
21	180077	SCREW, 5/16-18 X .75 HHC	2
22	1498	NUT, 5/16-18 REGHEXCTRLK	2
23	314119	ASSEMBLY, LIFT BRACKET	1
24	180077	SCREW, 5/16-18 X .75 HHC	2
25	120393	WASHER, FLAT .344 X .69 X .065	2
26	1498	NUT, 5/16-18 REGHEXCTRLK	2
27	313588	ASSEMBLY, QUILL	1
27-1	314272	QUILL, MACHINED CASTING	1
27-2	314274	TUBE, SPACER, STEEL	1
27-3	313576	BEARING, BALL 6204-2AA-C3	2
29	138485	WASHER, EXLK .320 X .61 X .03	5
30	321146	SPACER, SLEEVE .700 X 1.250 X .500	1
31	314273	PULLEY ASSEMBLY	1
32	22265	WASHER, FLAT .515 X 1.38 X .119	1
33	1500	NUT, 1/2-13 REGHCTRLK	1
34	321144	SHAFT, QUILL 30" MOWER - SF	1
35	313577	SHIELD, DUST, BEARING	1
36	313584	HUB, BLADE ADAPTOR	1
37	329988	BLADE, 30", TD MOWER, 0.7 WING	1
38	22265	WASHER, FLAT .515 X 1.38 X .119	1
39	1500	NUT, 1/2-13 REGHCTRLK	1
40	12229	BRACKET, IDLER ASSEMBLY	1
40-1	313510	BRACKET, ARM, IDLER	1
40-2	306973	BRAKE PAD - HARD-NF343 (X-31)	1
40-3	41601	RIVET, OVSET .187 DIA X .50 LONG	2
41	180113	SCREW, 5/16-18 X 3.00 HHC	1
42	45602	WASHER, FLAT .333 X .87 X .119	1
43	321145	SPACER, SLEEVE .322 X .63 X 2.310	1
44	44108	NUT, 5/16-18 HWDFLCTRLK	1
45	180081	SCREW, 5/16-18 X 1.25 HHC	1
46	44108	NUT, 5/16-18 HWDFLCTRLK	1
47	35410	SPRING, .071 X .62 X 4.37	1
48	302357	LINK	1
49	1498	NUT, 5/16-18 REGHEXCTRLK	1
50	50520	SPACER	1
51	126216	BOLT, 5/16-18 X .75 CARRLN	1
52	1498	NUT, 5/16-18 REGHEXCTRLK	1
53	314099	BRACKET, BAR, REAR STABILIZER	2
54	180079	SCREW, 5/16-18 X 1.00 HHC	4
55	58247	NUT, ADJUST	2
56	1498	NUT, 5/16-18 REGHEXCTRLK	4
57	51940	BOLT, .500 X .437 HSSH, 3/8-16	2
58	1498	NUT, 3/8-16 REGHXCTRLK	2
59	320605	BRACKET, LIFT BAR 30" SF	1
60	1498	NUT, 5/16-18 REGHEXCTRLK	2
61	180077	SCREW, 5/16-18 X .75 HHC	2

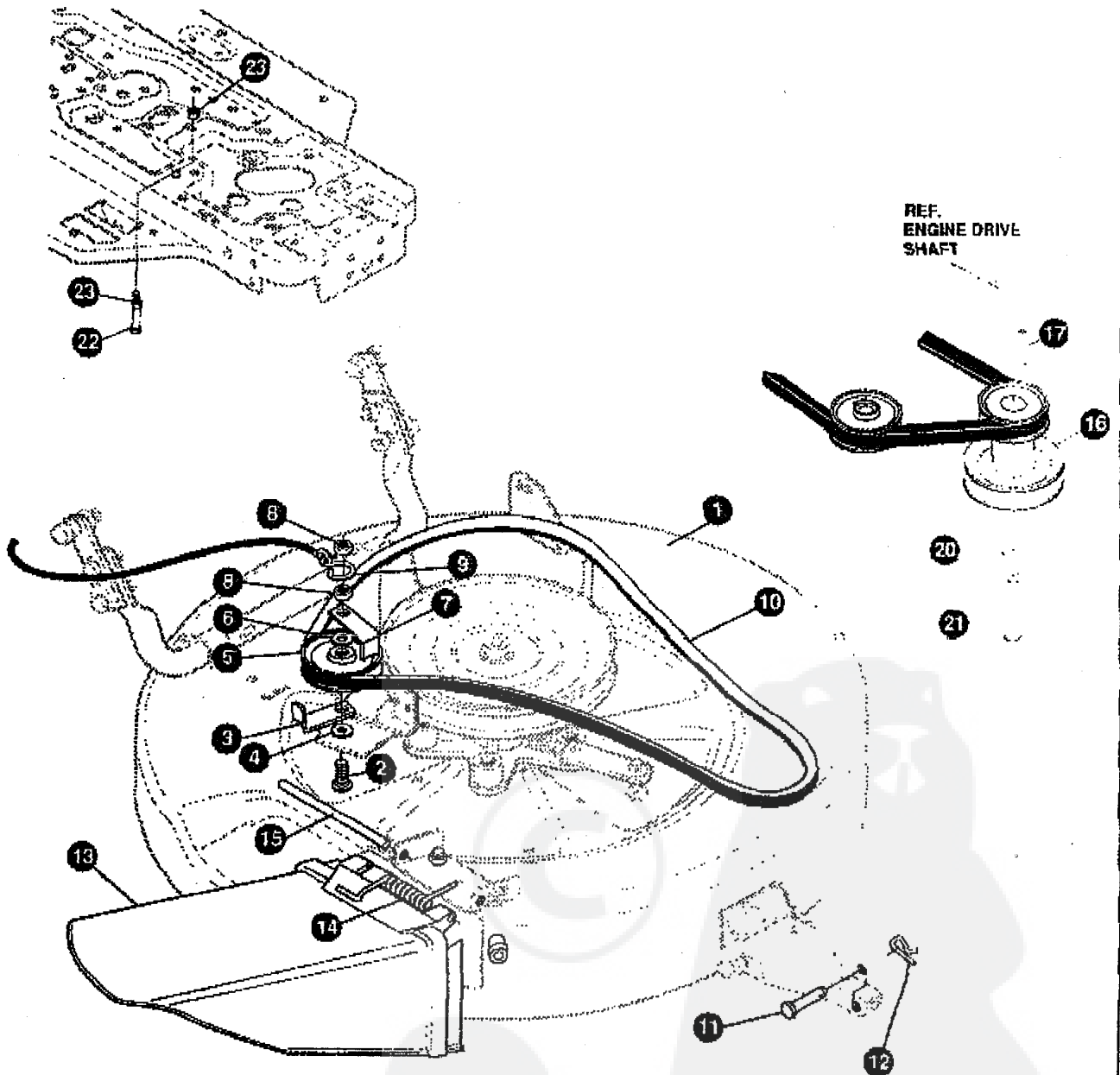
F3554-070**REPAIR PARTS**

NOTE: ALWAYS USE ORIGINAL EQUIPMENT PARTS.
Use of service/replacement parts other than original equipment parts may void your warranty.

**ALL UNNUMBERED
ITEMS ARE INTERCHANGEABLE
WITH OPPOSITE SIDE**

325643 C

F3554-070**FINAL DECK ASSEMBLY**

KEY#	PART#	DESCRIPTION	QTY
1	328711	ASSEMBLY, DECK, PRE-PAINT 30°	1
2	301340	BOLT, 3/8-16 X 2.50 CARR	1
3	39659	RETAINER, BELT	1
4	22265	WASHER, FLAT .515 X 1.38 X .119	1
5	45074	PULLEY, IDLER V4L, 3.06 X .72	1
6	25210	WASHER, FLAT .386 X 1.25 X .09	1
7	39659	RETAINER, BELT	1
8	1499	NUT, 3/8-16 REGHXCTRLK	2
9	310734	HOOK, 8, 10 GA. STEEL	1
10	321147	BELT, V 4L, 54.0 - MOD SEC	1
11	47817	PIN, CLEVIS LONG	1
12	56180	PIN, HAIR .091 DIA X 1.62 LONG	1
13	315314	CHUTE DEFLECTOR, 30° DECK	1
14	314975	SPRING, TORSION, CHUTE DEFLECTOR	1
15	304424	ROD, PIVOT, DECK .312 D X 7.25	1
16	328035	PULLEY, ENGINE, 2.94OF/5.5D/3.00D	1
17	28655	KEY, SQUARE .250 SQUARE X 2.50 LONG	1
20	120383	WASHER, REGSPTLK .459 X .78 X .12	1
21	182764	SCREW, 7/16-20 X 3.25 HHC	1
22	49930	SCREW, 3/8-16 X 7.50 HHC	1
23	1499	NUT, 3/8-16 REGHXCTRLK	2

F3554-070

ELECTRICAL ASSEMBLY

KEY#	PART#	DESCRIPTION	QTY
1	331453	WIRE HARNESS, SF, 8-12HP, B&S, W/AMM	1
2	322298	SPLICER	1
3	57444	TIE, CABLE BLACK NYLON, 5.62 LONG	1
4	41482	PRESS CLIP, 1.380 LONG .255 ID	2
5	303064	ASSEMBLY, LIGHT WIRE-1/4 TURN	1
6	52572	BULB, HEADLAMP	2
7	57444	TIE, CABLE BLACK NYLON, 5.62 LONG	1
8	41482	PRESS CLIP, 1.380 LONG .255 ID	2
9	327354	SWITCH, IGNITION & LIGHTS, DELTA	1
11	327352	NUT, 5/8-8 ACME DELTA FOR BOOT	1
12	327350	KEY, IGNITION	1
13	57476	SWITCH, SCREW MOUNT, DP, NG, NO BLACK	2
14	300302	SCREW, #10 X .50 HHTAPPST, BLACK	4
16	53716	SOLENOID	1
17	187745	SCREW, 1/4-20 X .75 HXSEMMA	2
18	1084	WASHER, FLAT .281 X 1.00 X .063	1
19	1502	NUT, 1/4-20 REGHEXCTRLK	2
20	271172	NUT, 1/4-20 REGHEXKEPS	1
21	271187	NUT, 5/16-24 HKEPS	2
22	57444	TIE, CABLE BLACK NYLON, 5.62 LONG	1
23	55511	WIRE, GROUND, 12.5'	1
24	271184	NUT, 5/16-18 HEXKEPS	1
25	57547	SWITCH, SEAT	1
26	160505	SCREW, 1/4-20 X .38 PHPNHMA	2
27	92693	BATTERY, 12V	1
28	329175	BATTERY BRACKET	1
29	995346	SCREW, 1/4-20 X .50 WAHTAP	1
30	187745	SCREW, 1/4-20 X .75 HXSEMMA	1
31	1502	NUT, 1/4-20 REGHEXCTRLK	1
32	180020	SCREW, 1/4-20 X .75 HHC	2
33	271172	NUT, 1/4-20 REGHEXKEPS	2
34	302031	FUSE, SPADE TYPE 32V 15A	1
35	9149	BRACKET, CABLE RETAINER	1
36	308201	INSULATOR, BATTERY BOOT, EURO	1
37	124818	NUT, 1/4-20 REGHXJAM	1

SCHEMATIC DRAWING

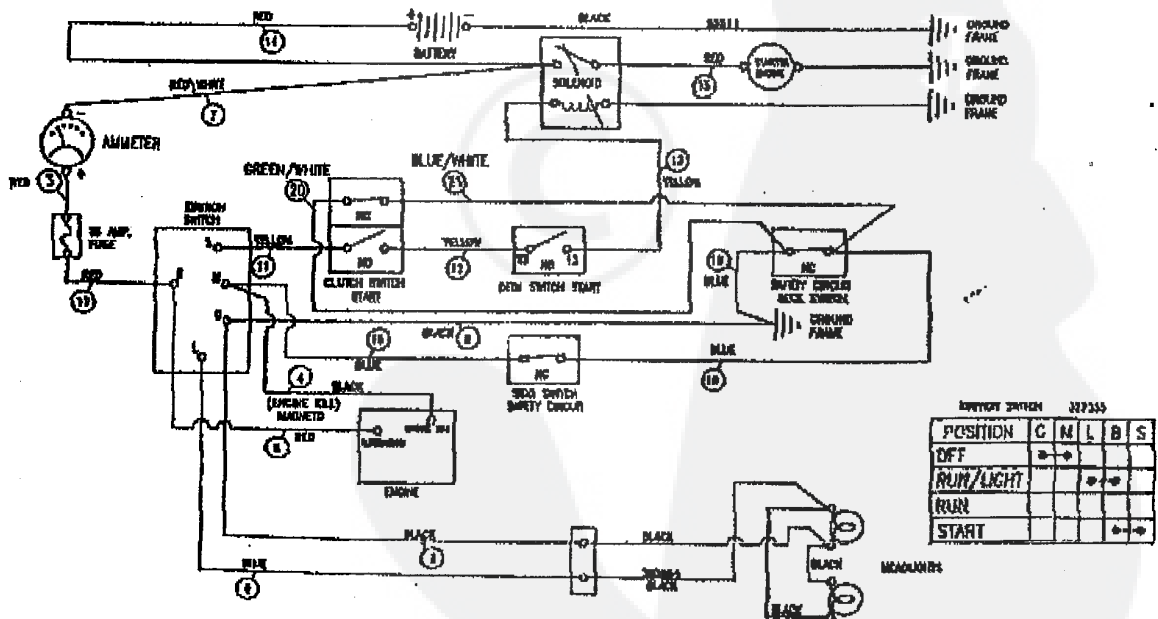

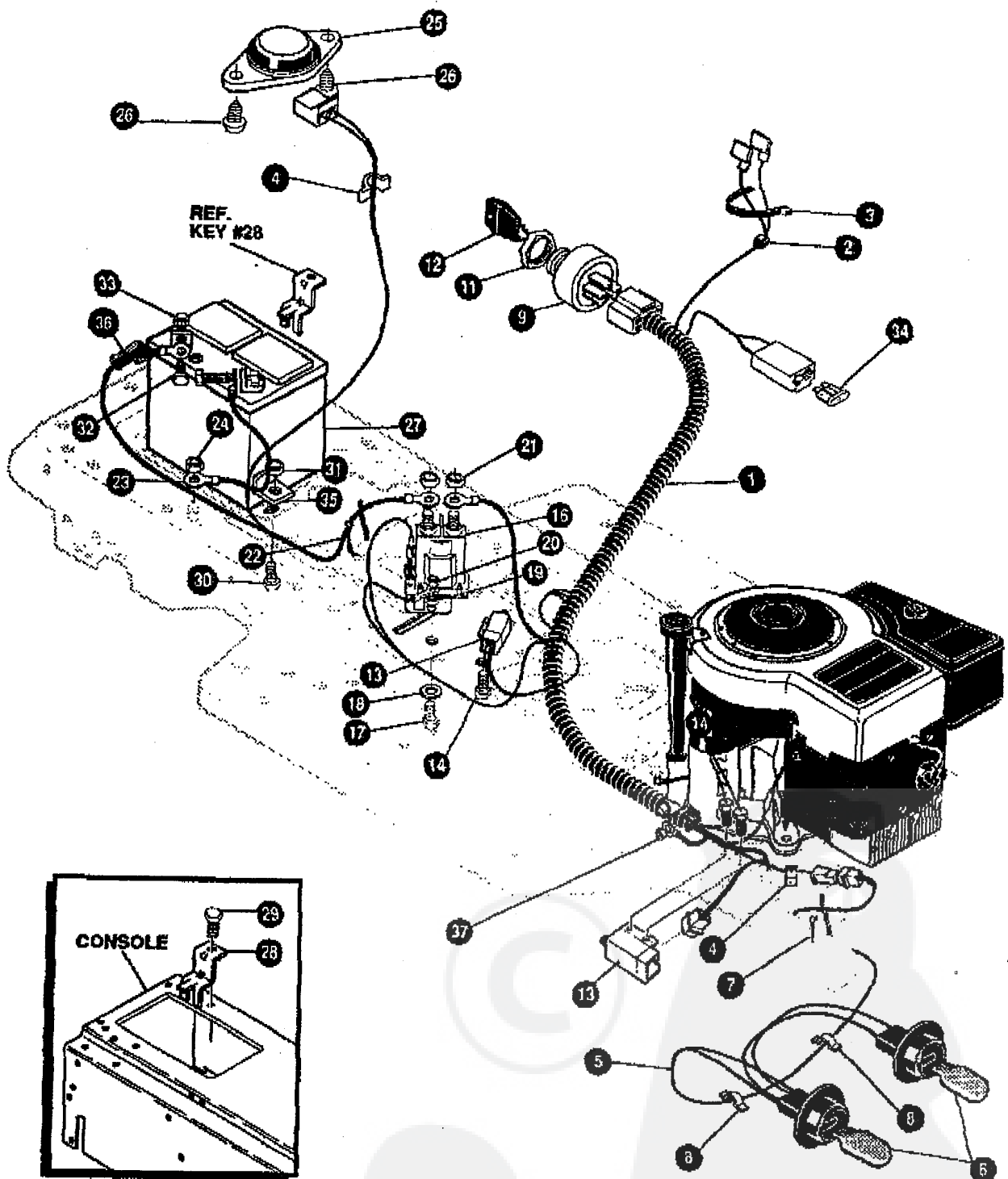
F3554-070**REPAIR PARTS**

NOTE: ALWAYS USE ORIGINAL EQUIPMENT PARTS.
Use of service/replacement parts other than original equipment parts may void your warranty.

**ALL UNNUMBERED
ITEMS ARE INTERCHANGEABLE
WITH OPPOSITE SIDE**

331995 B

F3554-070

REPAIR PARTS

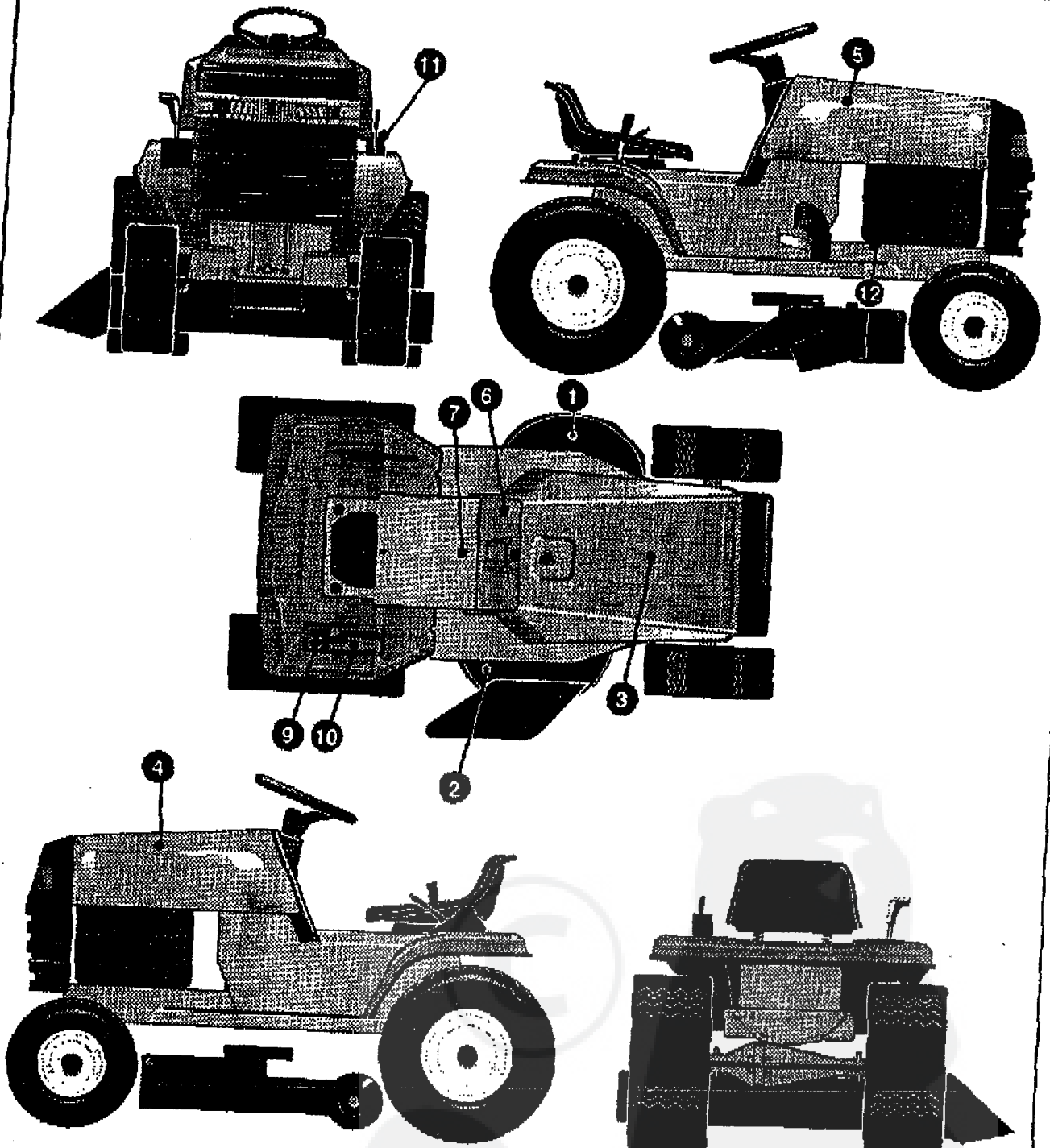

KEY#	PART#	DESCRIPTION	QTY
1	402700	DECAL, CAUTION, DECK, LH	1
2	402701	DECAL, CAUTION, DECK, RH	1
3	55832	PAD, FOAM, TOP HOOD, H-4	1
4	55833	PAD, FOAM, HOOD H-4, SIDE, LH	1
5	55834	PAD, FOAM, HOOD H-4, SIDE, RH	1
6	320686	DECAL, DASH, DYNAMARK	1
7	402747	DECAL, CONSOLE, SYMBOLIC, SF	1
8	311394	DECAL, SHIFT REVERSE/NEUTRAL	1
9	331013	DECAL, SHIFTER POSITION	1
10	402214	DECAL, HEIGHT ADJUST	1
11	402702	DECAL, BRAKE/CLUTCH	1

334936 B

F3554-070

DECAL ASSEMBLY

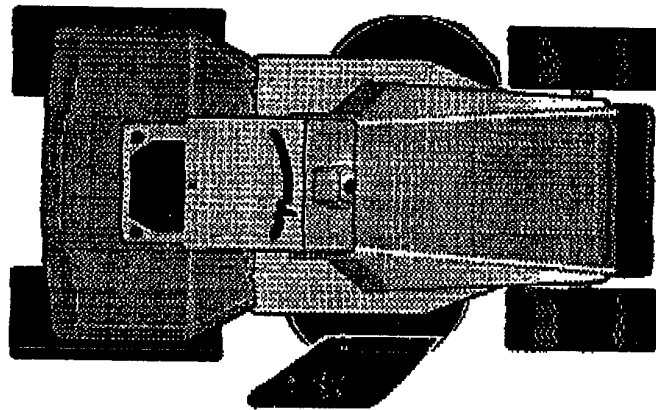
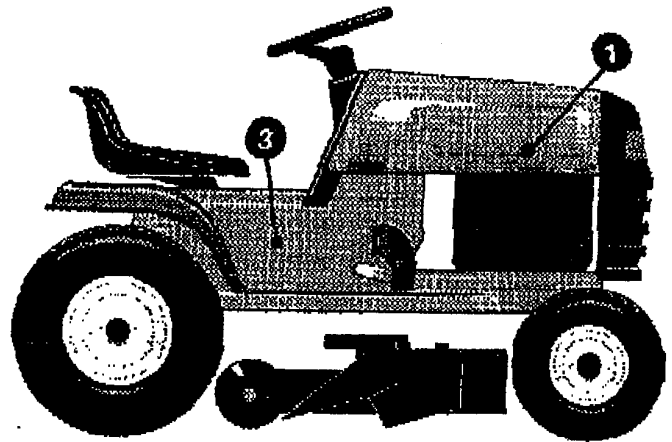
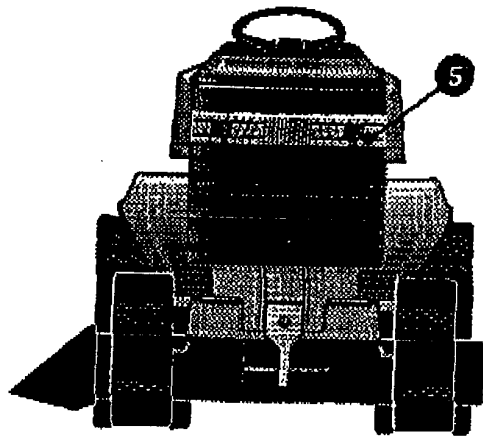

CONSOLE DETAIL

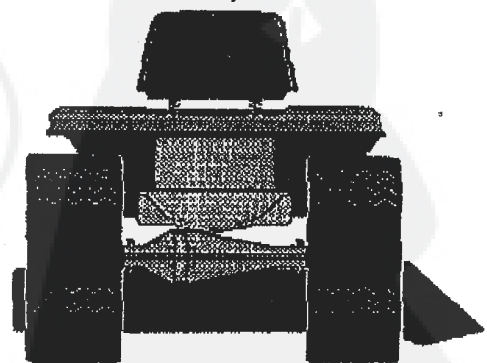
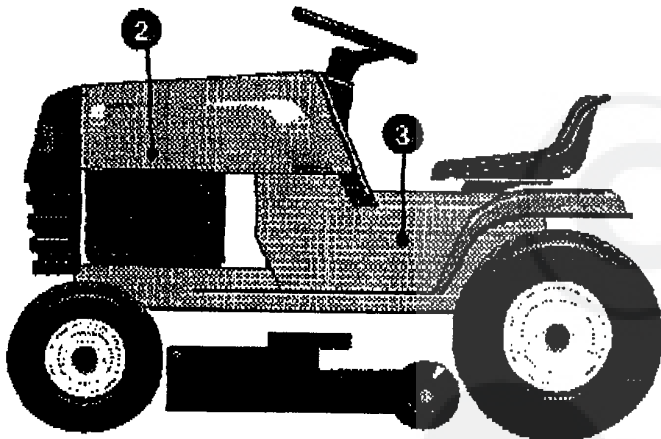
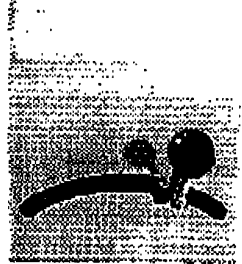

KEY#	PART#	DESCRIPTION	QTY
1	402390	DECAL, HOOD, RH, STATESMAN, H21, SF	1
2	402389	DECAL, HOOD, LH, STATESMAN, H21, SF	1
3	307B46	NAMEPLATE, 11/30, WHITE	2
5	314948	FOIL, LENS, DYNA-PRO REFLECTOR	1

F3554-070

REPAIR PARTS

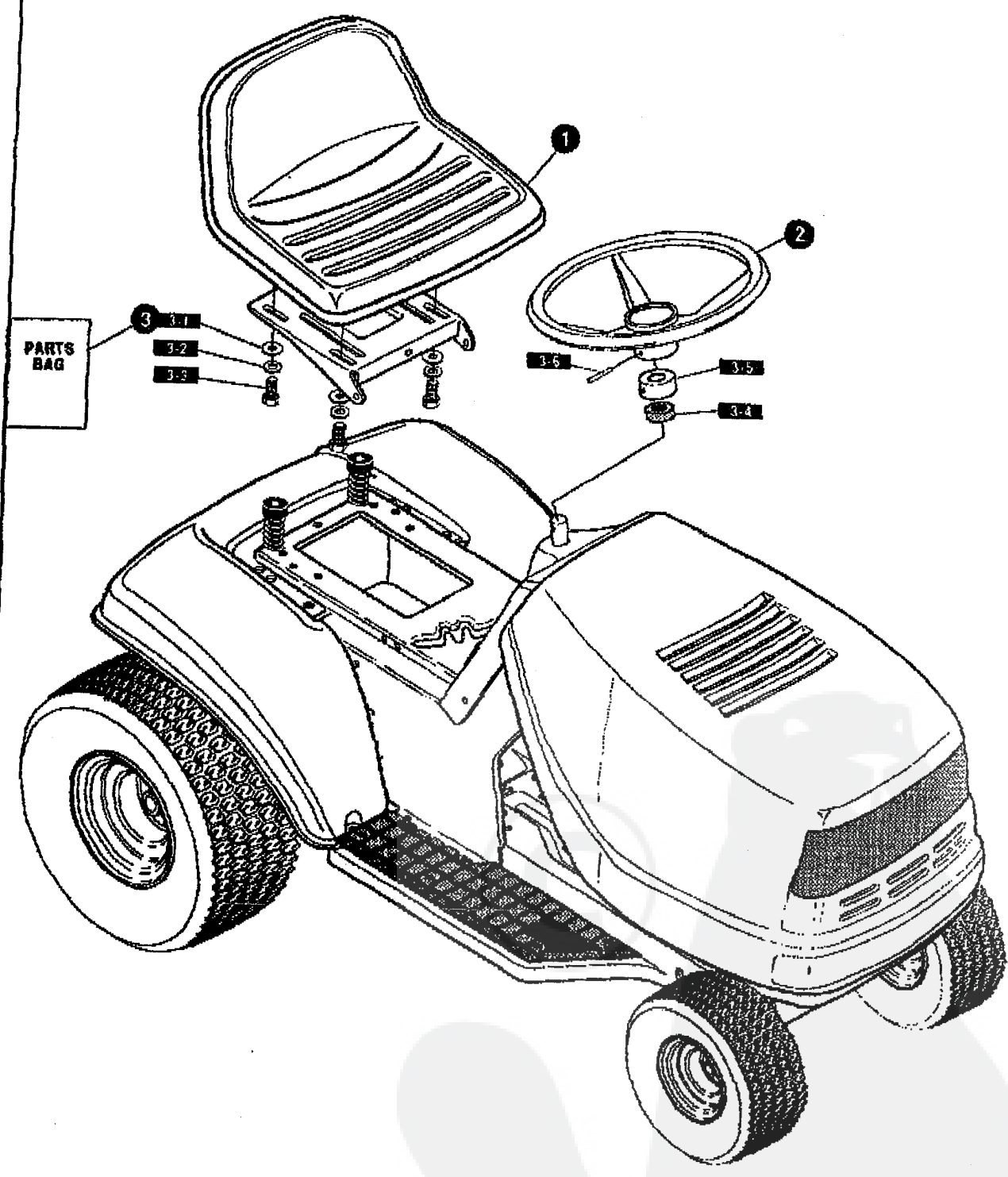

TREAD PATTERNS

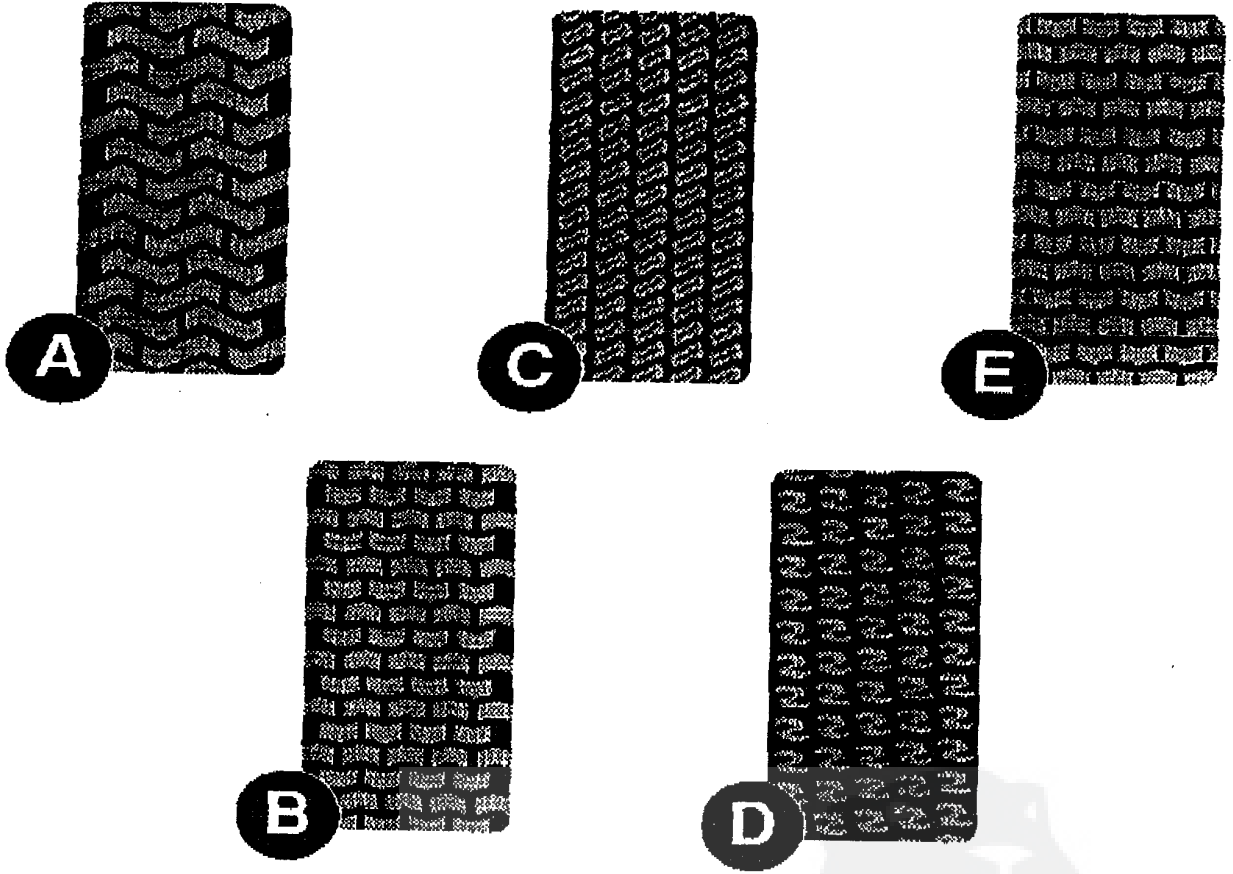

TIRE SIZE	"A"	"B"	"C"	"D"	"E"
11 X 4.00 - 5	42295	319679			
13 X 5.00 - 6	41060	319680			
15 X 6.00 - 6	39830	316702	301140	313952	
16 X 4.80 - 8		305035			
16 X 6.50 - 8	41081	319682		314539	
18 X 6.50 - 8		42091			
18 X 8.50 - 8	319683	317400			
18 X 9.50 - 8	41106	316701		313950	
20 X 8.00 - 8	319685	319684	57164	314584	331606
20 X 10.00 - 8	58276	319686		313654	
20 X 10.00 - 10	55893	319687			
23 X 9.50 - 12	53655	319690	319689	314370	

F3554-070**CUSTOMER ASSEMBLY**

KEY#	PART#	DESCRIPTION	QTY
1	310384	SEAT, MICHIGAN GEN, W/SWITCH HOLE	1
2	330510	STEERING WHEEL	1
3	331424	PARTS BAG ASSEMBLY SEAT/STEER	1
3-1	120393	WASHER, FLAT .344 X .69 X .065	4
3-2	120638	WASHER, HVSPTLK .328 X .60 X .09	4
3-3	180077	SCREW, 5/16-18 X .75 HHC	4
3-4	331322	COVER, STEERING SHAFT	1
3-5	301419	SPACER, STEERING SHAFT	1
3-6	456378	PIN, SPRING .250 DIA X 2.00 LONG	1

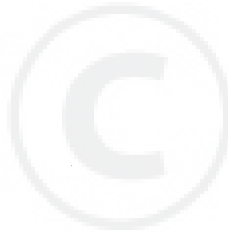

F3554-070

ACCESSORIES

Contact the dealer where your tractor was purchased for the available accessories. If you are unable to contact the dealer, write to the address on the warranty page of your operator's manual.

30" STANDARD LAWN RIDER

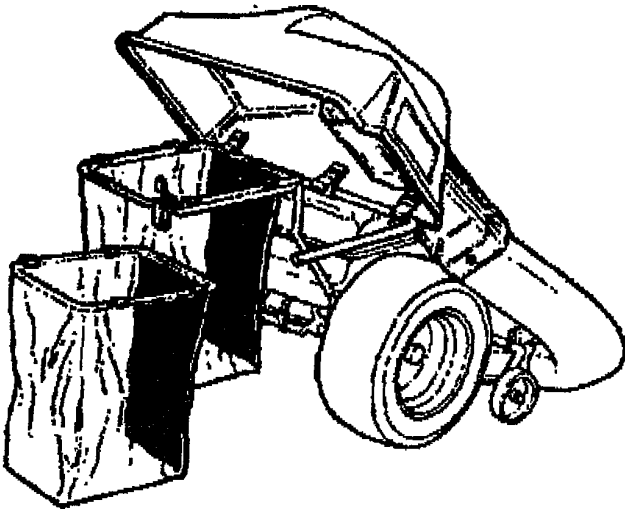

**Model #5708-17
Grass Collector (30" decks)**

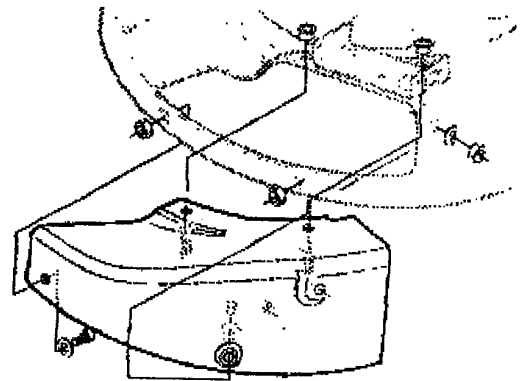

5714-00 Mulching Kit (30" Deck)

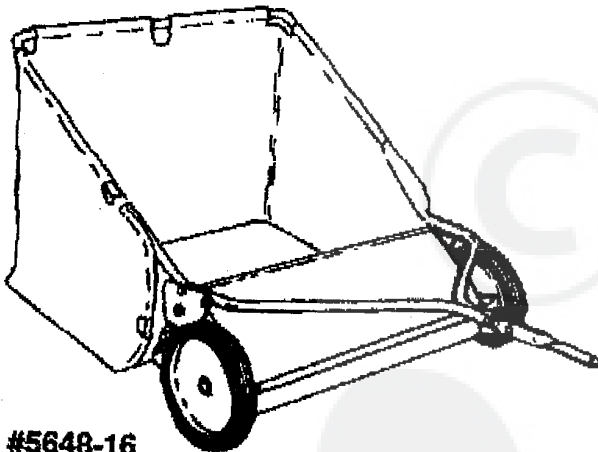

**Model #5648-16
Tow Behind Lawn Sweeper for Grass and Leaves**

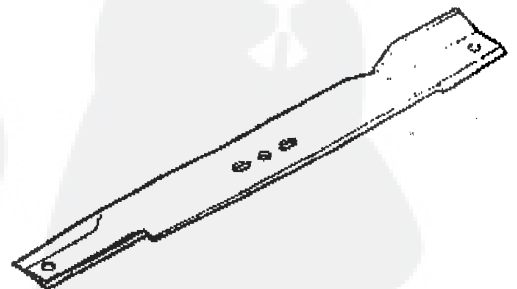

314275 -30" Standard Lift Blade

OTHER ACCESSORIES

Model	Description
5709-02	Front Weight Box - holds 35 lbs.
322397	30" Mulching blade