

REPAIR

PARTS MANUAL

Model F3554-250



12HP/38" Deck

HOW TO ORDER REPAIR PARTS

Only use a factory repair part. Repair parts, except for the engine or the transmission, are available from the store where the unit was purchased, a service shop recommended by the store, or an authorized service shop found in the yellow pages of the telephone directory.

If you cannot get a repair part or service as described above, call or write to the Central Parts Distributor shown on the back page of this manual or write: **Customer Service Department, Outdoor Power Equipment, PO Box 8000, Jackson, TN 38308, 1-800-247-7464**. Collect telephone calls will not be accepted. When you order, include the following information: 1- Complete Model Number (see nameplate), 2- Date of Manufacture, 3- Complete Part Number, 4- Description, and 5- Quantity.

Repair parts for the engine or the transmission are available from the manufacturer's authorized service center found in the yellow pages of the telephone directory. See the individual engine or transmission warranties.

- Read and keep this parts list book for future reference.
- This parts list book contains drawings and part numbers necessary to obtain repair parts.
- Record the following information about your unit. This information is necessary when ordering parts or in case of loss or theft.

WHERE PURCHASED: _____

DATE PURCHASED: Month _____ Day _____ Year _____

MODEL NO.: _____ DATE OF MANUFACTURE: _____

F3554-250

REPAIR PARTS

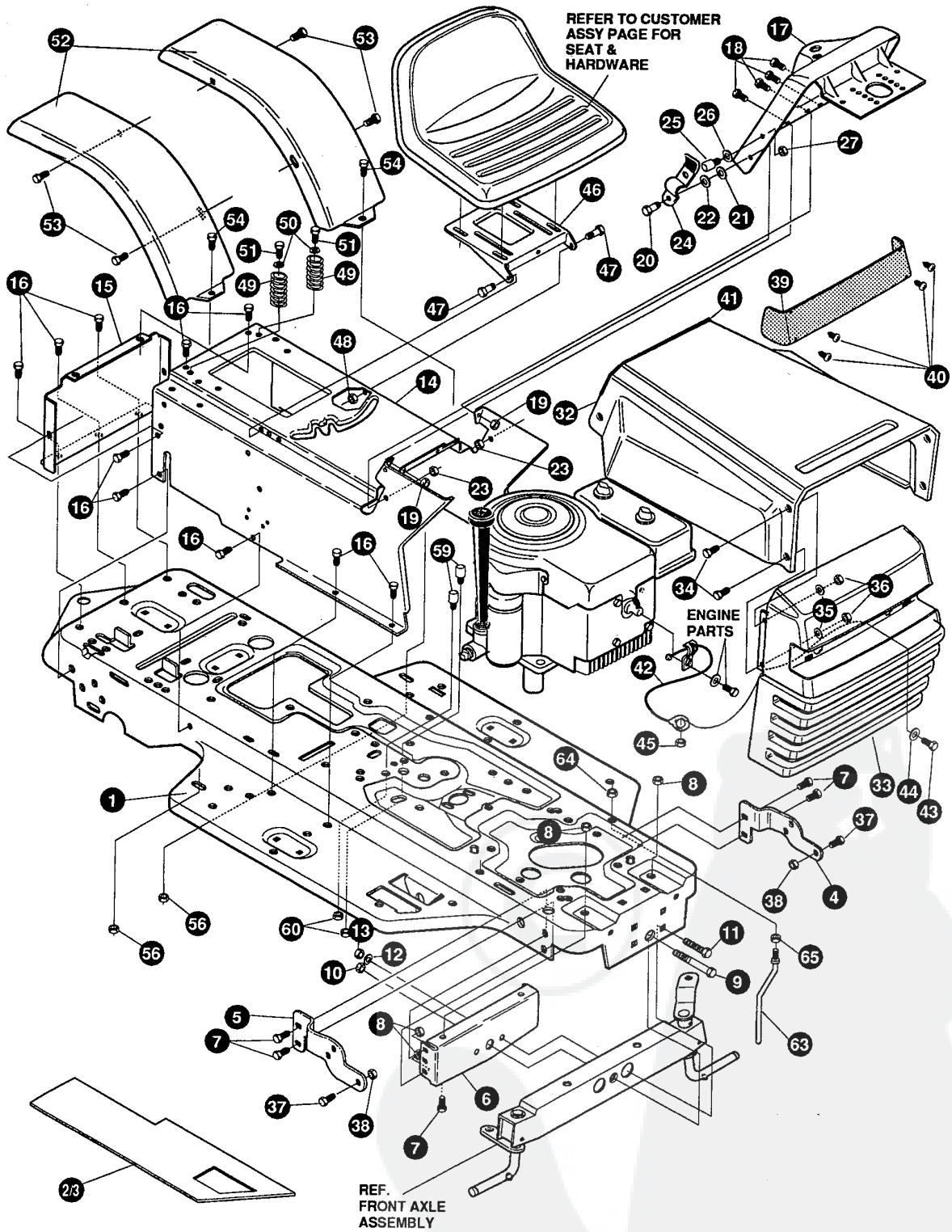

NOTE: ALWAYS USE ORIGINAL EQUIPMENT PARTS.
Use of service/replacement parts other than original equipment parts may void your warranty.

**ALL UNNUMBERED
ITEMS ARE INTERCHANGEABLE
WITH OPPOSITE SIDE**

332341A

F3554-250

CHASSIS & HOOD ASSEMBLY

KEY#	PART#	DESCRIPTION	QTY
1	331173-854	FRAME, MAIN	1
2	326732	FOOT PAD, LH	1
3	302916	FOOT PAD, RH	1
4	314579-853	BRACKET,GRILLE LH	1
5	314578-853	BRACKET,GRILLE RH	1
6	56362-853	BRKT,SUPPORT, FRONT AXLE	1
7	328154	SCREW, 5/16-18X1.0WDFLLK	6
8	55273	NUT, 5/16-18 WDFLLKLRG	6
9	29616	BOLT, .625X1.890 HSH 1/2-20	1
10	274654	NUT, 1/2-20 REGHXCTRLK	1
11	180138	SCREW, 3/8-16X3.00 HHC	2
12	2483	WASHER,.39IDX1.25DX.07 BELLVIL	2
13	1499	NUT, 3/8-16 REGHXCTRLK	2
14	331796-854	CONSOLE	1
15	56235-854	CONSOLE, REAR COVER	1
16	995346	SCREW, 1/4-20X .50 WAHTAP	15
17	320466-854	DASH	1
18	44811	SCREW, 1/4-20X .75 WAHTAP	4
19	50352	NUT, 1/4-20 WDFLLK TOPLOCK	2
20	8482	BOLT, .375X .156 HSH 5/16-18	2
21	120394	WASHER, FLAT .406X .81X.065	2
22	120393	WASHER, FLAT .344X .69X.065	2
23	1498	NUT, 5/16-18 REGHEXCTRLK	2
24	57159	LATCH, .94WDX.047 ASSY HOOD	2
25	53446	PIN, 5/16-18 HOOD LATCH	2
26	138538	WASHER, REGINTLK.320X.61X.03	2
27	45174	NUT, 5/16-18 HEXWDFLLK WHIZ	2
32	314538-854	HOOD	1
33	325401	GRILLE	1
34	274672	SCREW, 1/4-20X .63 WAHHC	4
35	120392	WASHER, FLAT .281X .63X.065	4
36	1502	NUT, 1/4-20 REGHEXCTRLK	4
37	36149	BOLT, .375X .500 HSH 5/16-18	2
38	1498	NUT, 5/16-18 REGHEXCTRLK	2
39	302333	LENS, SMOKED W/TAB NO LOGO	1
40	57796	SCREW, #6 X .50 PLASTITE/HI-LO	4
41	56304	EDGING,WIDE BLK	25 IN.
42	311094	LANYARD,HOOD 11.75LG H15 VANG	1
43	180020	SCREW, 1/4-20X .75 HHC	1
44	120392	WASHER, FLAT .281X .63X.065	1
45	1502	NUT, 1/4-20 REGHEXCTRLK	1
46	58367-853	PLATE, SEAT	1
47	20507	BOLT, .437X .156 HSH 5/16-18	2
48	1498	NUT, 5/16-18 REGHEXCTRLK	2
49	330463	SPRING, SEAT 1.50ODX2.25LG	2
50	120392	WASHER, FLAT .281X .63X.065	2
51	995346	SCREW, 1/4-20X .50 WAHTAP	2
52	43970-854	FENDER	2
53	995346	SCREW, 1/4-20X .50 WAHTAP	4
54	126358	BOLT, 5/16-18X1.00 CARRLN	2
56	55273	NUT, 5/16-18 WDFLLKLRG WHIZ	2
59	53446	PIN, 5/16-18 HOOD LATCH	2
60	271184	NUT, 5/16-18 HEXKEPS	2
63	50653	GUIDE, BELT	1
64	41529	NUT, 3/8-16 HXCTRLKJAM	1
65	271190	NUT, 3/8-16 HEXKEPS	1
	336425	FRENCH OPERATOR'S MANUAL	1
	336832	PARTS MANUAL	1

F3554-250

REPAIR PARTS

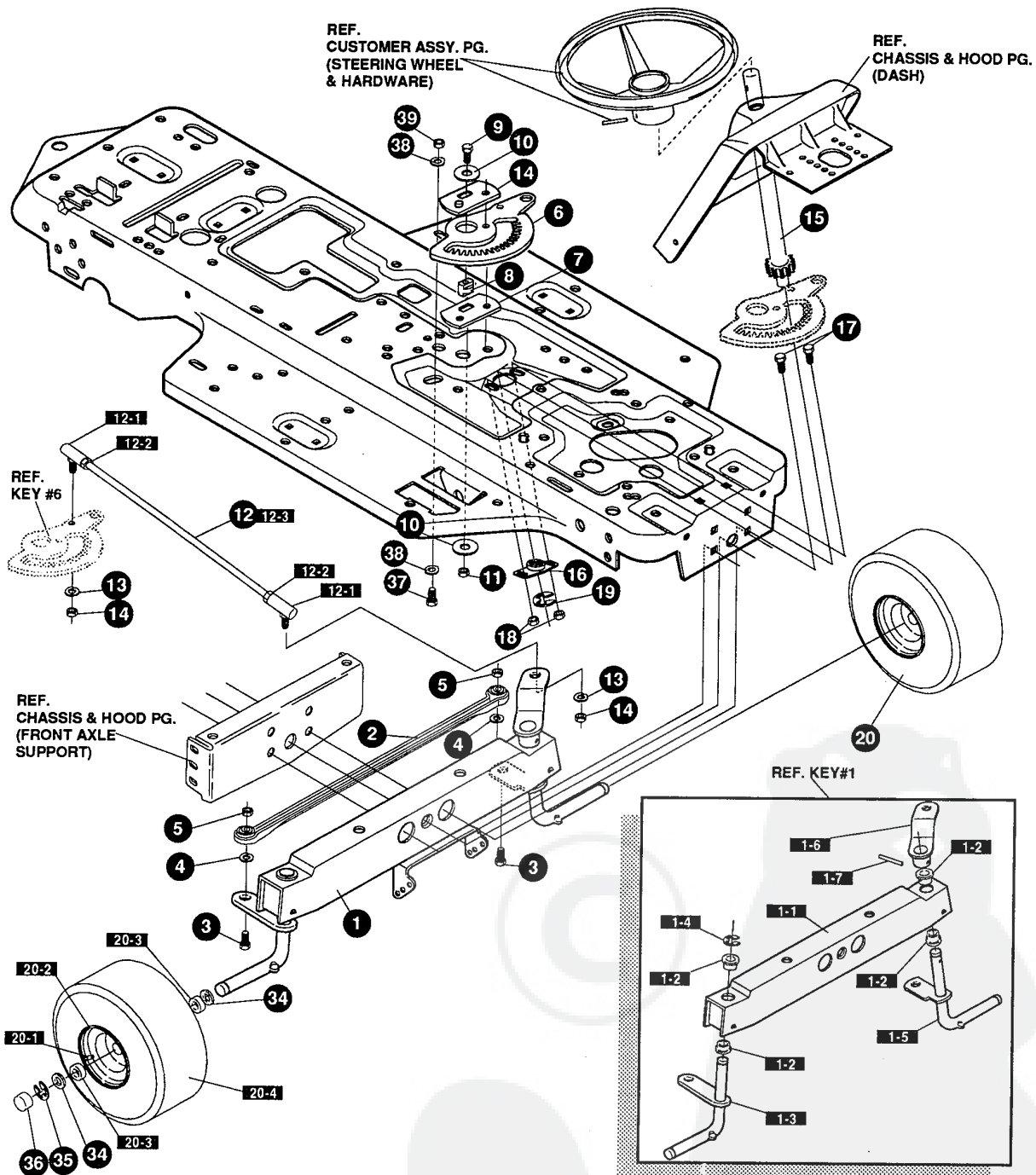

NOTE: ALWAYS USE ORIGINAL EQUIPMENT PARTS.
 Use of service/replacement parts other than original equipment parts may void your warranty.

ALL UNNUMBERED ITEMS ARE INTERCHANGEABLE WITH OPPOSITE SIDE

324972 H

F3554-250**STEERING ASSEMBLY**

KEY#	PART#	DESCRIPTION	QTY
1	*	AXLE, FRONT ASSEMBLY, SF, LONG	1
1-1	324915-853	ASSEMBLY, FRONT AXLE	1
1-2	50546	BEARING, FLANGE .759 ID X 1.002 OD X .75	4
1-3	310368	SPINDLE, ASSEMBLY, RH, LONG	1
1-4	36625	RING, RETEX .57 X .05 TRU 5133-75	1
1-5	310367	SPINDLE, ASSEMBLY, LH, LONG	1
1-6	327619-853	ARM ASSEMBLY, FRONT STEERING	1
1-7	454565	PIN, SPRING .250 DIA X 1.25 LONG	1
2	302688	ASSEMBLY, TIE ROD, 19.31 LONG	1
3	180124	SCREW, 3/8-16 X 1.25 HHC	2
4	120382	WASHER, REGSPTLK .393 X .68 X .10	2
5	1499	NUT, 3/8-16 REGHXCTRLK	2
6	327399	GEAR, SECTOR	1
7	333289	PLATE SECTOR	2
8	330021	BUSHING, SECTOR, GEAR	1
9	181643	SCREW, 3/8-24 X 1.50 HHC	1
10	845	WASHER, FLAT .390 X 1.25 X .119	2
11	412349	NUT, 3/8-24 HXCTRLK	1
12	328808	DRAG LINK ASSEMBLY, 17.69 LONG	1
12-1	57158	BALL JOINT, 3/8 THD, SHORT STUD	2
12-2	124925	NUT, 3/8-24 REGHEXJAM	2
12-3	56190	DRAG LINK	1
13	120382	WASHER, REGSPTLK .393 X .68 X .10	2
14	120369	NUT, 3/8-24 REGHEX	2
15	327834	SHAFT, PIN-STEER, BLACK	1
16	325692	BEARING, FLANGE .50 ID X 1.370 OD	1
17	326505	SCREW, 1/4-20 X .75 (TQ 30-35 FT#)	2
18	46931	NUT, 1/4-20 WDFL MAC-LOCK	2
19	20864	RING, RET E .39 X .04 TRU 5133-50	1
20	302828	TIRE & RIM ASSEMBLY, PU 15 X 6.0 X 6	2
20-1	24167	VALVE STEM	
20-2	39829	RIM, WHEEL	
20-3	314416	BEARING, FLANGE	
20-4	316702	TIRE, 15 X 6 X 6	
34	642	WASHER, FLAT .755 X 1.31 X .075	4
35	36625	RING, RETEX .57 X .05 TRU 5133-75	2
36	40394	HUB CAP, 1.500 ID X 7/8 LONG	2
37	180124	SCREW, 3/8-16 X 1.25 HHC	1
38	120394	WASHER, FLAT .406 X .81 X .065	2
39	45171	NUT, 3/8-16 HWDWL WHIZ-LOCK	1

* ORDER INDIVIDUAL PARTS - ASSEMBLY NOT AVAILABLE

F3554-250

REPAIR PARTS

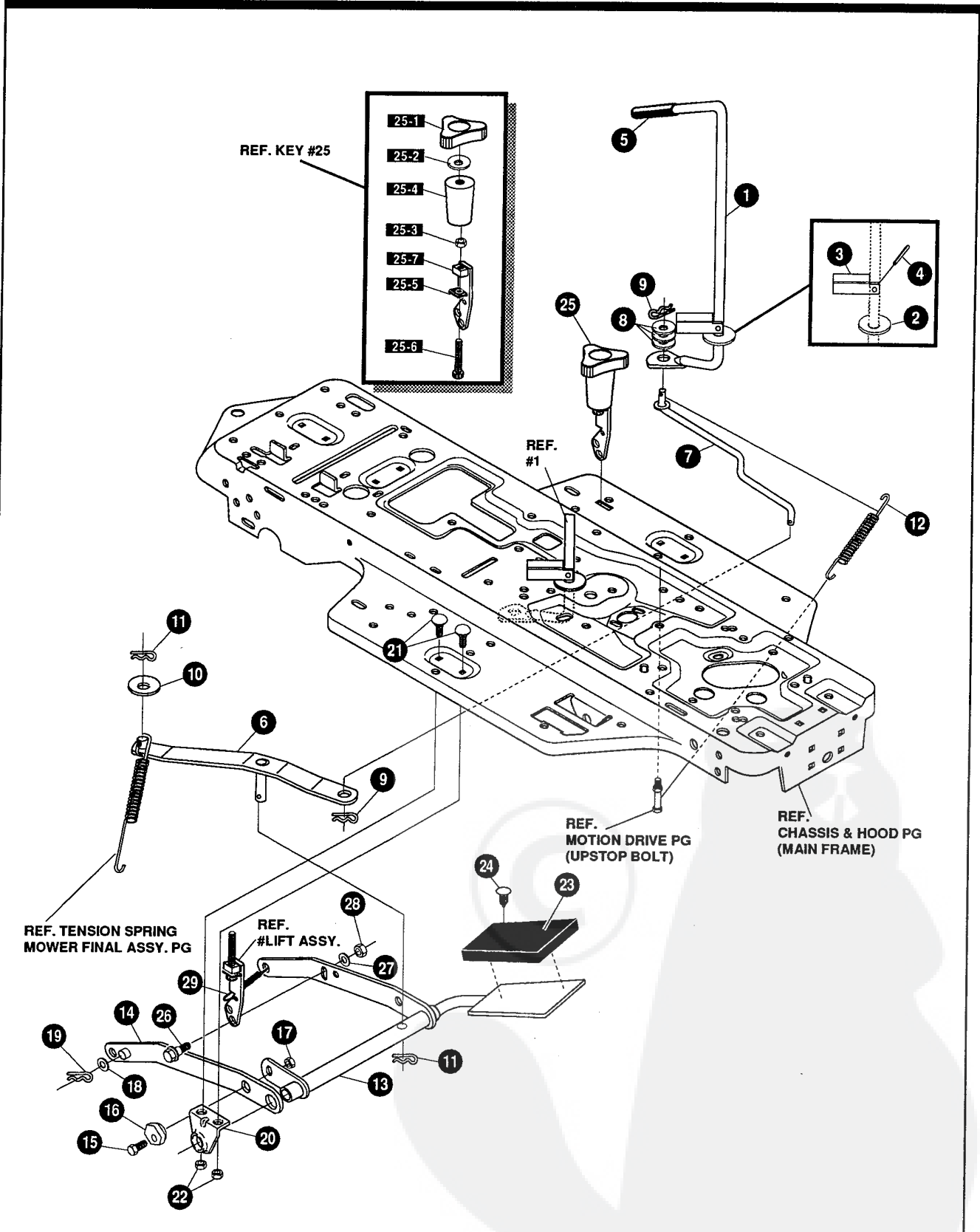

NOTE: ALWAYS USE ORIGINAL EQUIPMENT PARTS.
 Use of service/replacement parts other than original equipment parts may void your warranty.

ALL UNNUMBERED ITEMS ARE INTERCHANGEABLE WITH OPPOSITE SIDE

331233B

F3554-250**MOWER SUSPENSION ASSEMBLY**

KEY#	PART#	DESCRIPTION	QTY
1	325591	LEVER, CLUTCH, RH, PTO	1
2	22265	WASHER, FLAT .515 X 1.38 X .119	1
3	305225	STOP, PTO ENGAGE	1
4	326386	PIN, SPRING.187 DIA X 1.13 LONG	1
5	331624	KNOB, ROUND 1.50 DIA OR GRIP, SF	1
6	325587-853	STRAP ASSEMBLY, PTO BELCRANK, SF	1
7	325590	ROD, BELCRANK LINK, SF	1
8	274517	WASHER, FLAT .406 X .73 X .063	3
9	8260	PIN, HAIR .091 DIA X 1.66 LONG	2
10	25210	WASHER, FLAT .386 X 1.25 X .09	1
11	8260	PIN, HAIR .091 DIA X 1.66 LONG	2
12	325802	SPRING, .69 X 7.75 X .0897, TENSION	1
13	326533-853	LIFT ASSEMBLY, LH, PEDAL-LIFT	1
14	325130-853	LIFT ASSEMBLY, RH, SF	1
15	180079	SCREW, 5/16-18 X 1.00 HHC	1
16	58247	NUT, ADJUST	1
17	1498	NUT, 5/16-18 REGHEXCTRLK	1
18	417098	WASHER, FLAT .531 X 1.06 X .063	2
19	8260	PIN, HAIR .091 DIA X 1.66 LONG	2
20	325495-853	BRACKET, REAR HANG SUSP	1
21	330967	BOLT, 5/16-18 X 1.00 CARR	4
22	1498	NUT, 5/16-18 REGHEXCTRLK	4
23	328596	PAD, LIFT PEDAL	1
24	309235	FASTENER, RATCHET, BLACK	1
25	327934	ASSEMBLY, LATCH, SUS MOWER, SF	1
25-1	325860	KNOB, FLUTED TORQUE, BLACK	1
25-2	446363	WASHER, FLAT .375 X .88 X .082	1
25-3	45905	NUT, 3/8-16 HWDFLK MACK	1
25-4	326113	COVER, TOP SLEEVE, PEDAL-LIFT	1
25-5	324983	WASHER, RUBBER 3/8 X .75 SQ	1
25-6	325832	BOLT, SUS MOWER LATCH, SF	1
25-7	325831-853	LATCH, SUS MOWER, SF	1
26	25086	BOLT, .500 X .375 HSSH, 5/16-18	1
27	4230	WASHER, FLAT .328 X .68 X .104	1
28	1498	NUT, 5/16-18 REGHEXCTRLK	1
29	35410	SPRING, .071 X .62 X 4.37	1

F3554-250

REPAIR PARTS

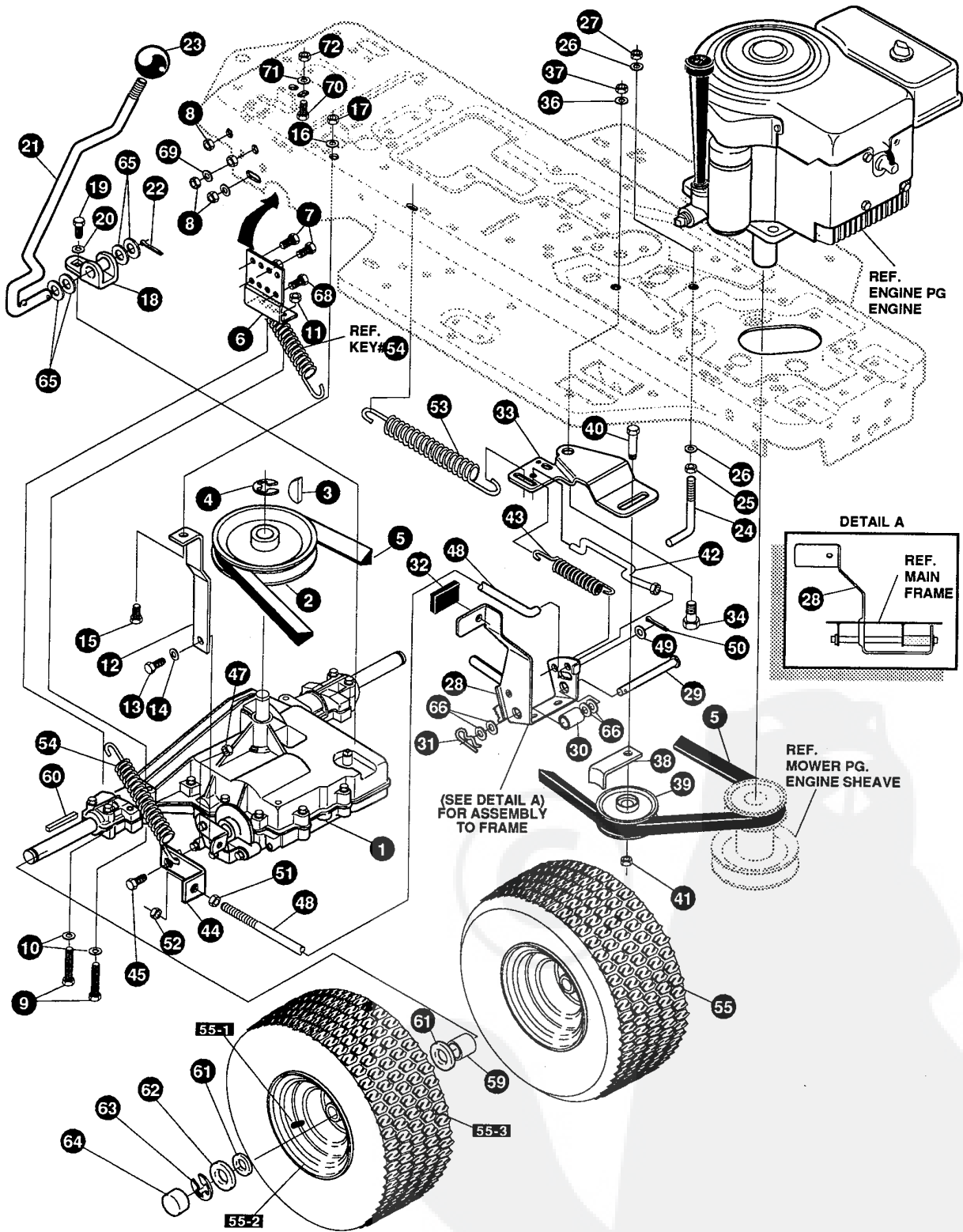

NOTE: ALWAYS USE ORIGINAL EQUIPMENT PARTS.
Use of service/replacement parts other than original equipment parts may void your warranty.

ALL UNNUMBERED ITEMS ARE INTERCHANGEABLE WITH OPPOSITE SIDE

332340B

F3554-250

MOTION DRIVE ASSEMBLY

KEY#	PART#	DESCRIPTION	QTY
1	*	TRANSAXLE, FOOTE, 4360-5	1
2	303109	PULLEY, 6.6 OD, V4L T/A	1
3	50795	KEY, HI-PRO, 606 .75 DIA X .187 WD	1
4	22053	RING, RETEX .58 X .035 TRU 5100-62	1
5	54758	BELT, V 4L, 82.00, SF, DRIVE	1
6	326615-853	BRACKET, TRANSAXLE	2
7	180077	SCREW, 5/16-18 X .75 HHC	4
8	1498	NUT, 5/16-18 REGHEXCTRLK	8
9	180091	SCREW, 5/16-18 X 2.50 HHC	4
10	120393	WASHER, FLAT .344 X .69 X .065	4
11	1498	NUT, 5/16-18 REGHEXCTRLK	4
12	323126	BRACKET, STABILIZER, BLACK	1
13	35498	SCREW, 5/16-18 X .75 WAHTAP	1
14	120638	WASHER, HVSP TLK .328 X .60 X .09	1
15	180079	SCREW, 5/16-18 X 1.00 HHC	1
16	138485	WASHER, EXLK .320 X .61 X .03	1
17	1498	NUT, 5/16-18 REGHEXCTRLK	1
18	335218	SHIFT BRACKET, P930/4360	1
19	56255	SCREW, 1/4-28 X .75 NYLHHC	1
20	57157	WASHER, .750 X .250 SP-TRANSAXLE	1
21	331800	SHIFT LEVER (DANA)	1
22	137185	PIN, COTTER .125 DIA X 1.00 LONG	1
23	55514	KNOB, ROUND 1.50 DIA, BLACK	1
24	49896	BELT GUIDE	1
25	271184	NUT, 5/16-18 HEXKEPS	1
26	120393	WASHER, FLAT .344 X .69 X .065	2
27	1498	NUT, 5/16-18 REGHEXCTRLK	1
28	331836	ASSEMBLY, PEDAL, BRAKE, CLUTCH	1
29	319676	PIN, CLEVIS .500 D X 4.87 LONG	1
30	331972	SPACER, SLEEVE .53 X .62 X 1.240	1
31	56180	PIN, HAIR .091 DIA X 1.62 LONG	1
32	48761	PAD, CLUTCH/BRAKE PEDAL	1
33	321969-853	IDLER ARM BRACKET, TRACTION	1
34	329989	BOLT, .625 X .135 HSH, 5/16-18	1
36	45602	WASHER, FLAT .333 X .87 X .119	1
37	1498	NUT, 5/16-18 REGHEXCTRLK	1
38	39659	RETAINER, BELT	1
39	35374	PULLEY, IDLER V4L, 3.06 X .62	1
40	45892	BOLT, 3/8-16 X 1.50 CARRSN	1
41	1499	NUT, 3/8-16 REGHXCTRLK	1
42	333175	CLUTCH ROD ASSEMBLY, .268 DIA 3.92	1
43	326780	SPRING, 3/8 OD X 2.18 X .055 TENSION	1
44	323127	BRACKET, BRAKE ROD, BLACK	1
45	20507	BOLT, .437 X .156 HSH, 5/16-18	1
47	1498	NUT, 5/16-18 REGHEXCTRLK	1
48	323222	BRAKE ROD, RIDER BLACK	1
49	120393	WASHER, FLAT .344 X .69 X .065	1
50	121222	PIN, COTTER .090 DIA X .75 LONG	1
51	271184	NUT, 5/16-18 HEXKEPS	1
52	44108	NUT, 5/16-18 HWDFLCTRLK	1
53	327867	SPRING, 3/4 OD X 7.75 X .091 TENSION	1
54	35410	SPRING .071 X .62 X 4.37	1
55	326363	TIRE & RIM, 20 X 8.00-8	2
55-1	24167	VALVE STEM	
55-2	326362	RIM, WHEEL	
55-3	319684	TIRE & RIM 20X8.00-8	
59	57479	SPACER, SLEEVE .75 X 1.25 X 1.32	2
60	52928	KEY, SQUARE .187 SQUARE X 2.25 LONG	2
61	642	WASHER, FLAT .755 X 1.31 X .075	4
62	42815	WASHER, FLAT .755 X 1.53 X .07	2
63	36625	RING, RETEX .57 X .05 TRU 5133-75	2
64	40394	HUB CAP, 1.500 ID X 7/8 LONG	2
65	5950	WASHER, FLAT .505 X .88 X .13	4
66	2968	WASHER, FLAT .504 X .75 X .059	4
68	327917	SCREW, 5/16-18X1.50HHCFT	4
69	73787	WASHER, FLAT .330 X .75 X .1793	4
70	180022	SCREW, 1/4-20 X 1.00 HHC	1
71	120380	WASHER, REGSP TLK .263 X .49 X .07	1
72	120375	NUT, 1/4-20 REGHEX	1

* CONTACT YOUR NEAREST TRANSAXLE DEALER FOR PARTS & SERVICE

F3554-250

REPAIR PARTS

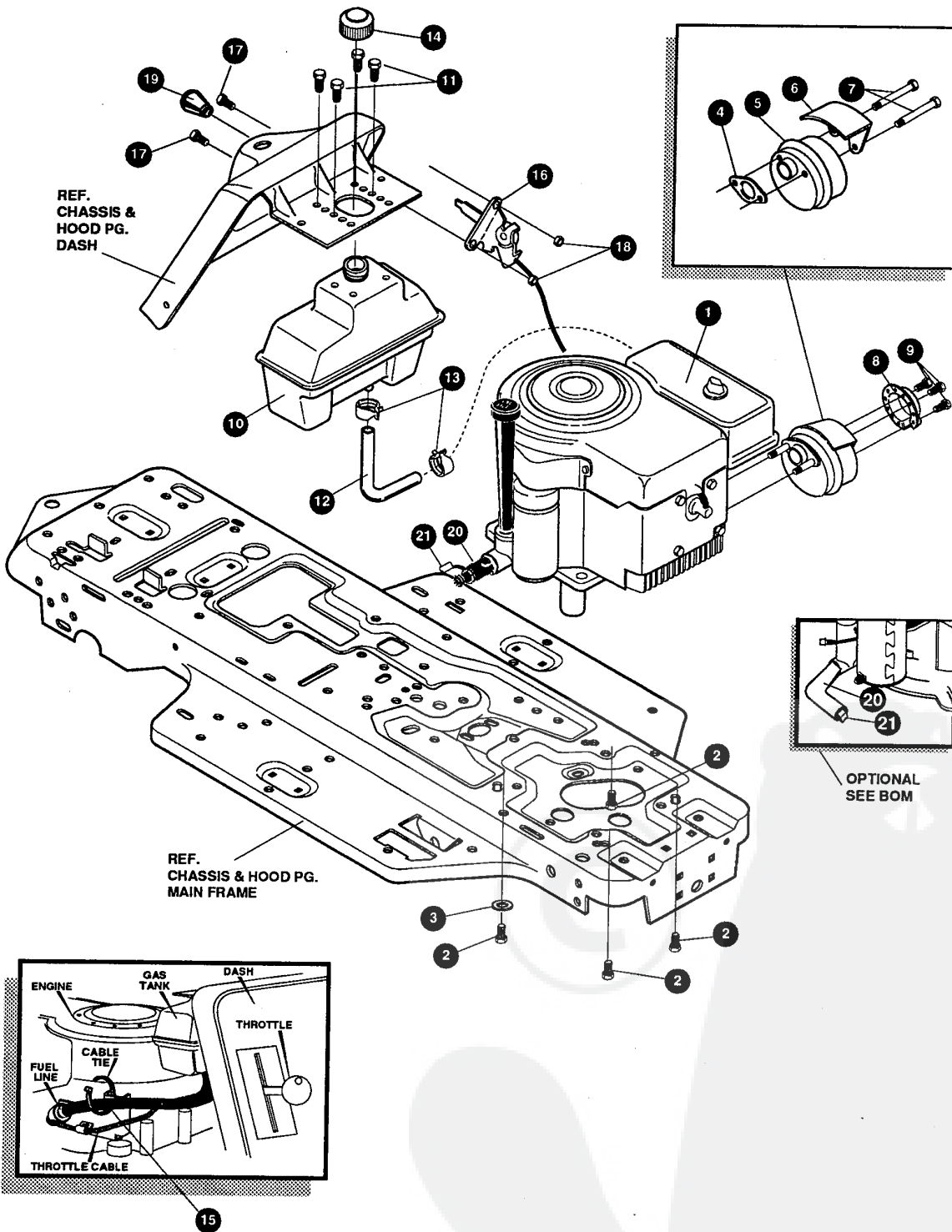

NOTE: ALWAYS USE ORIGINAL EQUIPMENT PARTS.
Use of service/replacement parts other than original equipment parts may void your warranty.

**ALL UNNUMBERED
ITEMS ARE INTERCHANGEABLE
WITH OPPOSITE SIDE**

327140D

F3554-250**ENGINE & CONTROL ASSEMBLY**

KEY#	PART#	DESCRIPTION	QTY
1	*	ENGINE, 12-12.5HP, B&S, IC DUAL	1
2	50947	SCREW, 3/8-16 X 1.25 WAHHTAP	4
3	138489	WASHER, EXLK .384 X .69 X .04	1
4	46708	GASKET, MUFFLER	1
5	57908	MUFFLER-DOMESTIC/EXPORT, ROUND	1
6	54767	SHIELD, HEAT, FOR ROUND MUFFLER	1
7	54980	SCREW, 5/16-18 X 3.50 HHC	2
8	323423	DEFLECTOR, MUFFLER PARTIAL	1
9	35287	SCREW, #8-32 X .38 HHWATAP	3
10	314989	TANK, FUEL 1 GALLON, CLEAR	1
11	300303	SCREW, .25 X .75 X .51HHWAPLASTITE	4
12	42258	TUBING, .25 X .50 X BULK GAS LINE	12.0"
13	47345	CLAMP, HOSE SCREW TYPE	2
14	46704	CAP, GAS 1-1/2-7 THD, BLACK	1
15	57444	TIE, CABLE BLACK NYLON, 5.62 LONG	1
16	320031	THROTTLE CONTROL	1
17	274707	SCREW, 10-24 X .50 WAHMA	2
18	308459	NUT, #10-24 HXHDNYLK	2
19	50607	KNOB, ROUND THROTTLE, BLACK	1
20	325547	OIL DRAIN VALVE OR TUBE	1
21	43989	CAP OR PLUG FOR OIL DRAIN	1

* SEE ENGINE MANUAL

F3554-250

REPAIR PARTS

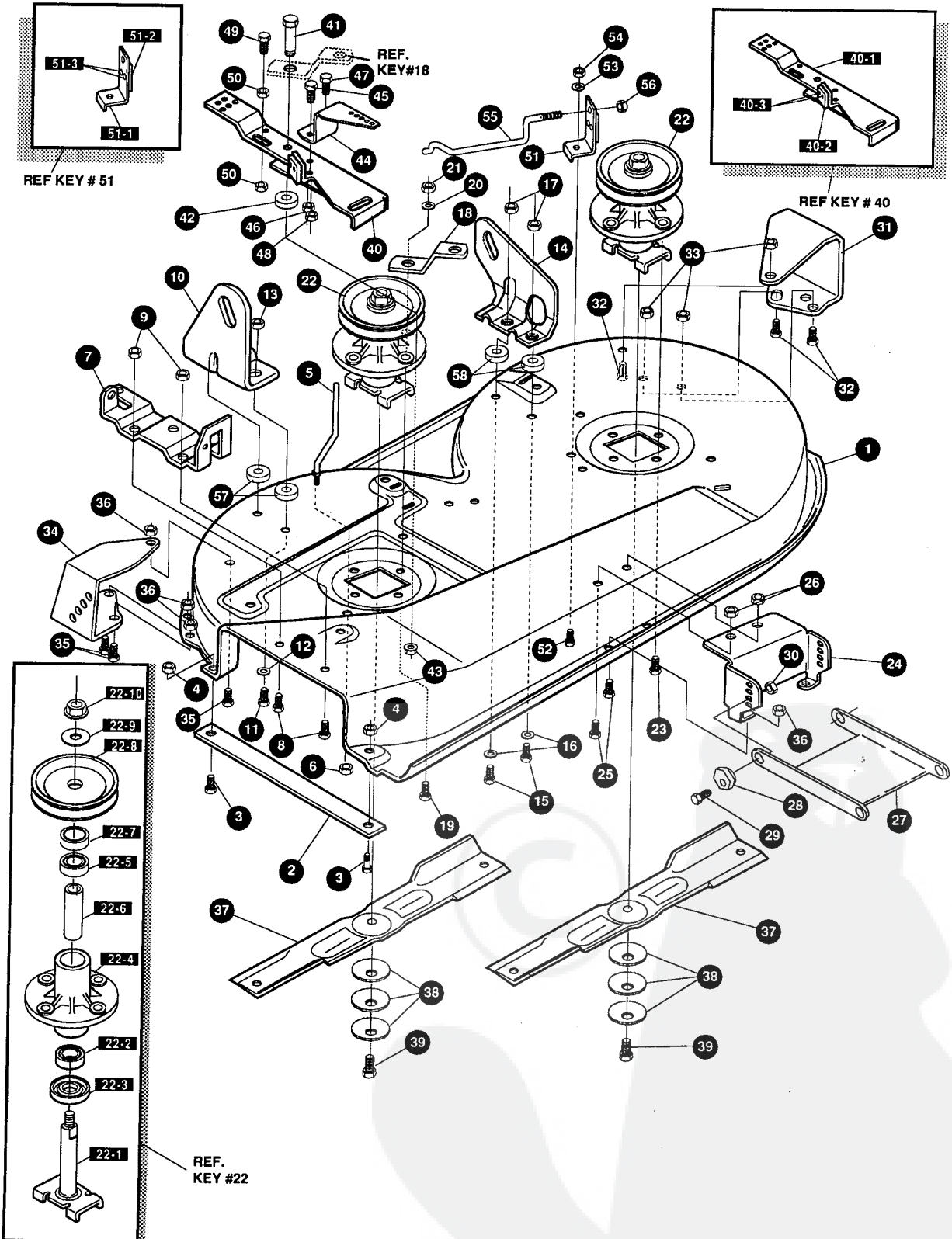

NOTE: ALWAYS USE ORIGINAL EQUIPMENT PARTS.
 Use of service/replacement parts other than original
 equipment parts may void your warranty.

**ALL UNNUMBERED
 ITEMS ARE INTERCHANGEABLE
 WITH OPPOSITE SIDE**

333272 C

F3554-250

PRE-PAINTED DECK ASSEMBLY

KEY#	PART#	DESCRIPTION	QTY
1	325106	38" DECK KIT	1
2	326295-853	BAR, SKID	1
3	126216	BOLT, 5/16-18 X .75 CARRLN	2
4	271184	NUT, 5/16-18 HEXKEPS	2
5	57318	GUIDE, BELT 5/16-18 THD	1
6	1498	NUT, 5/16-18 REGHEXCTRLK	1
7	313928	BRACKET, CHUTE	1
8	180073	SCREW, 5/16-18 X .50 HHC	2
9	1498	NUT, 5/16-18 REGHEXCTRLK	2
10	313929	BRACKET, RH, LIFT REAR	1
11	180081	SCREW, 5/16-18 X 1.25 HHC	2
12	120393	WASHER, FLAT .344 X .69 X .065	2
13	1498	NUT, 5/16-18 REGHEXCTRLK	2
14	310667	BRACKET, LH, LIFT REAR	1
15	180081	SCREW, 5/16-18 X 1.25 HHC	2
16	120393	WASHER, FLAT .344 X .69 X .065	2
17	1498	NUT, 5/16-18 REGHEXCTRLK	2
18	315302-853	BRACKET, IDLER SUPPORT	1
19	300345	SCREW, 5/16-18 X 1.38 WAHTAP	1
20	120393	WASHER, FLAT .344 X .69 X .065	1
21	1498	NUT, 5/16-18 REGHEXCTRLK	1
22	56424-853	QUILL ASSEMBLY, 36/39/40/43	2
22-1	56425	SHAFT/SADDLE 36"	1
22-2	49562	BEARING, BALL 6203-2AA-C3 ARMORED	1
22-3	50616	DUST SHIELD	1
22-4	55547	QUILL CASTING (1046)	1
22-5	49562	BEARING, BALL 6203-2AA-C3 ARMORED	1
22-6	50818	SPACER, SLEEVE .669 X .88 X 3.797	1
22-7	51449	SPACER, SLEEVE .672 X .93 X .438	1
22-8	313898	PULLEY, 26/36" QUILL, V5L	1
22-9	56365	WASHER, SPECIAL QUILL	1
22-10	1282	NUT, 7/16-20 WDFLLK	1
23	35498	SCREW, 5/16-18 X .75 WAHTAP	7
24	312526	SUPPORT, LIFT DECK FRONT	1
25	180077	SCREW, 5/16-18 X .75 HHC	4
26	1498	NUT, 5/16-18 REGHEXCTRLK	4
27	58305-853	BRACKET, LINK DECK FRONT	1
28	58247	NUT, ADJUST	2
29	180079	SCREW, 5/16-18 X 1.00 HHC	2
30	1498	NUT, 5/16-18 REGHEXCTRLK	2
31	312477	BRACKET, LH, WHEEL	1
32	180077	SCREW, 5/16-18 X .75 HHC	3
33	1498	NUT, 5/16-18 REGHEXCTRLK	3
34	300102-853	WHEEL BRACKET, RH	1
35	180077	SCREW, 5/16-18 X .75 HHC	3
36	1498	NUT, 5/16-18 REGHEXCTRLK	3
37	309069	BLADE, 19.69 LOW-LIFT	2
38	2483	WASHER, .39 ID X 1.25 D X .07 BELLVIL	6
39	39573	SCREW, 3/8-24 X 1.00 NYLHHC	2
40	300491-853	IDLER ARM ASSEMBLY	1
40-1	300490-853	IDLER ARM, 36, 38, 39, & 45 SD	1
40-2	306973	BRAKE PAD - HARD-NF343 (X-31)	1
40-3	41601	RIVET, OVSET .187 DIA X .50 LONG	2
41	300180	BOLT, .50 X1.88 HHSH, 3/8-16	1
42	996416	WASHER, FLAT .391 X 1.00 X .125	1
43	45171	NUT, 3/8-16 HWDFL WHIZ-LOCK	1
44	326249-853	BRACKET, EXTENSION IDLER	1
45	180077	SCREW, 5/16-18 X .75 HHC	1
46	1498	NUT, 5/16-18 REGHEXCTRLK	1
47	180020	SCREW, 1/4-20 X .75 HHC	1
48	1502	NUT, 1/4-20 REGHEXCTRLK	1
49	121954	SCREW, 1/4-20 X 2.00 HHC	1
50	271172	NUT, 1/4-20 REGHEXKEPS	2
51	303247	ASSEMBLY, BLADE BRAKE 36, 39, 45	1
51-1	303246	BRAKE ARM	1
51-2	306973	BRAKE PAD - HARD-NF343 (X-31)	1
51-3	135624	RIVET, TRSET .185 DIA X .41 LONG	2
52	180077	SCREW, 5/16-18 X .75 HHC	1
53	120393	WASHER, FLAT .344 X .69 X .065	1
54	1498	NUT, 5/16-18 REGHEXCTRLK	1
55	300316	ROD, BRAKE RELEASE, 14.7 39" DECK	1
56	1502	NUT, 1/4-20 REGHEXCTRLK	1
57	314702	SPACER, SLEEVE .344 X 1.00 X .500	2
58	314702	SPACER, SLEEVE .344 X 1.00 X .500	2

F3554-250

REPAIR PARTS

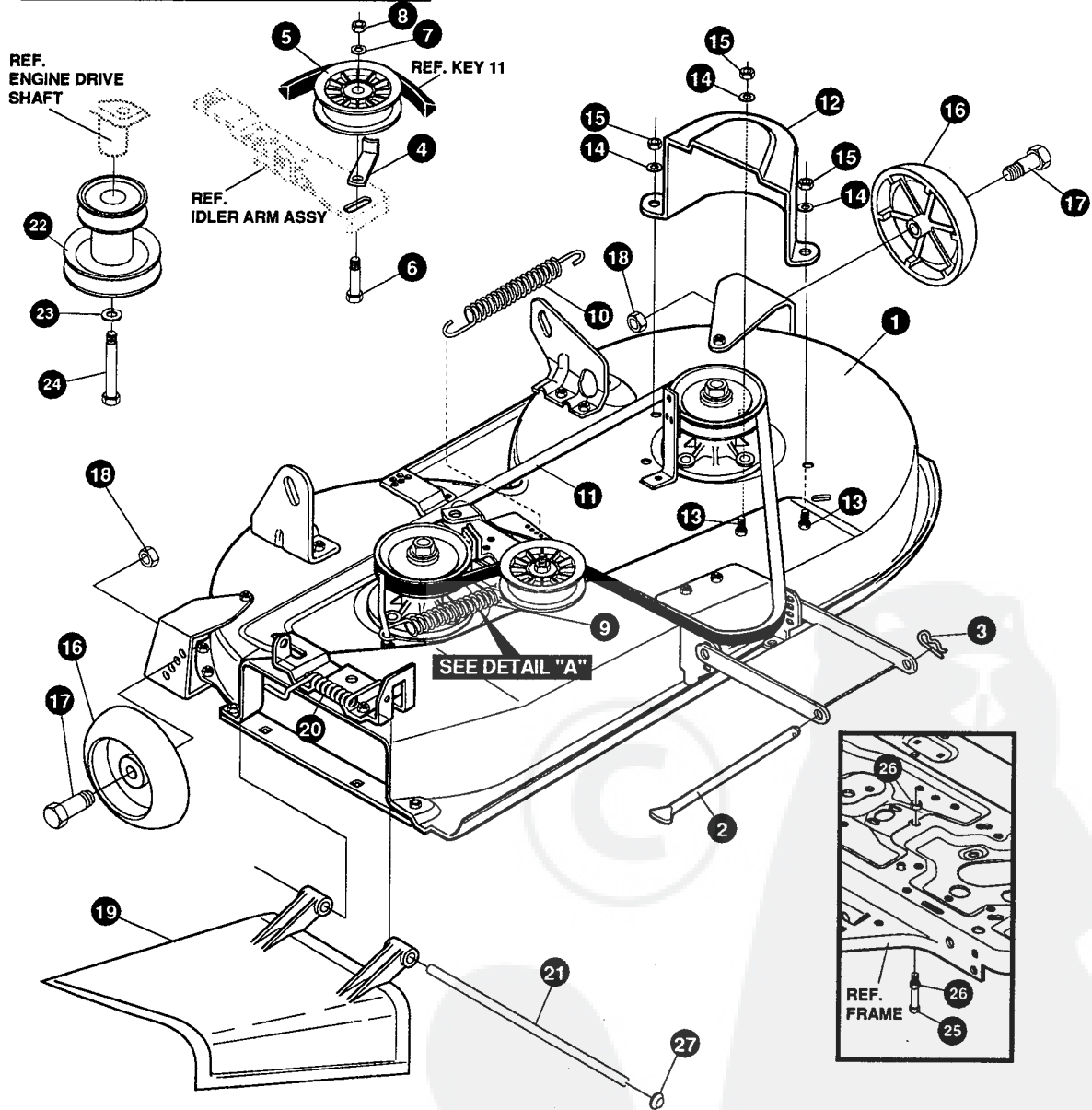
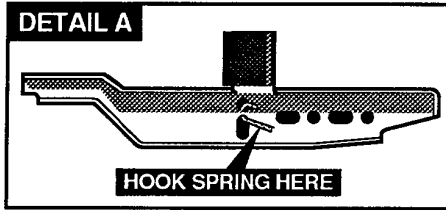

NOTE: ALWAYS USE ORIGINAL EQUIPMENT PARTS.
 Use of service/replacement parts other than original equipment parts may void your warranty.

ALL UNNUMBERED ITEMS ARE INTERCHANGEABLE WITH OPPOSITE SIDE

333274 B

F3554-250**FINAL DECK ASSEMBLY**

KEY#	PART#	DESCRIPTION	QTY
1	329456	ASSEMBLY, DECK, 38"	1
2	58306	ROD, DECK HITCH	1
3	8260	PIN, HAIR .091 DIA X 1.66 LONG	1
4	1346	RETAINER, BELT	1
5	310326	PULLEY, IDLER BFF 4.00 WIDE FL	1
6	57325	BOLT, 3/8-16 X 2.00 CARRSN	1
7	120382	WASHER, REGSPTLK .393 X .68 X .10	1
8	120377	NUT, 3/8-16 REGHX	1
9	322064	SPRING, .75 X 8.4 X .105 TENSION	1
10	326256	SPRING, .75 X 10.0 X .105 TENSION	1
11	300680	BELT, V 5L, 77.75, KEVLAR	1
12	328257	GUARD, BELT LH, PLASTIC	1
13	180077	SCREW, 5/16-18 X .75 HHC	3
14	120393	WASHER, FLAT .344 X .69 X .065	3
15	1498	NUT, 5/16-18 REGHEXCTRLK	3
16	302611	GAUGE WHEEL, EURO 6.00 OD X 1.38 WD	2
17	23763	BOLT, .500 X 1.390 HSSH, 3/8-16	2
18	1499	NUT, 3/8-16 REGHXCTRLK	2
19	57818	CHUTE DEFLECTOR, 36", 39", 45"	1
20	314975	SPRING, TORSION, CHUTE DEFLECTOR	1
21	334908	KIT FOR 57317 PIVOT ROD	1
22	328034	PULLEY, ENGINE, V3L, 4.00 OFFSET	1
23	120383	WASHER, REGSPTLK .459 X .78 X .12	1
24	433146	SCREW, 7/16-20 X 4.25 HHC, BLACK	1
25	180128	SCREW, 3/8-16 X 1.75 HHC	1
26	1499	NUT, 3/8-16 REGHXCTRLK	2
27	332179	CAP, PUSH ON, FOR DIA .250 ROD	1

F3554-250

REPAIR PARTS

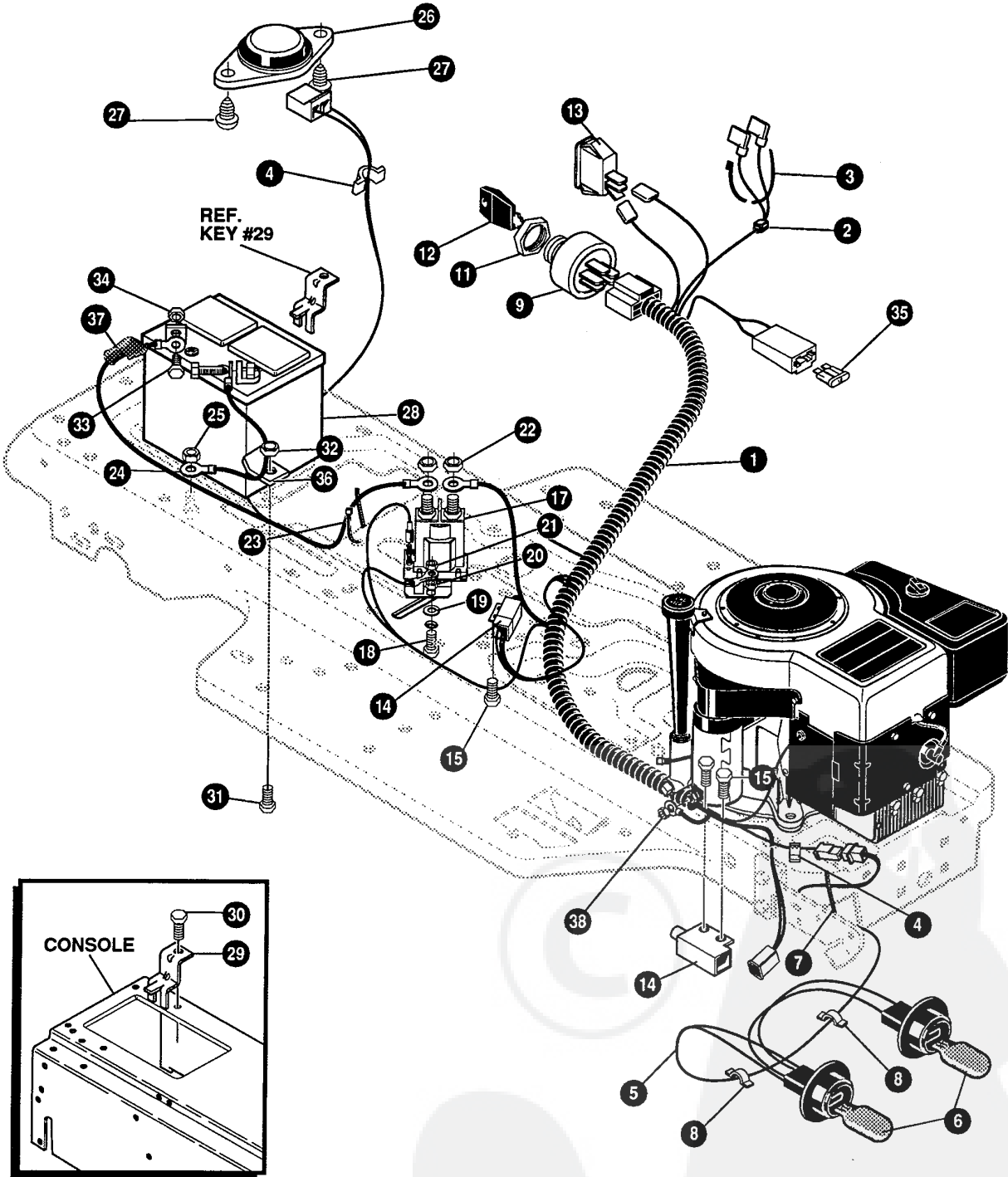

NOTE: ALWAYS USE ORIGINAL EQUIPMENT PARTS.
Use of service/replacement parts other than original equipment parts may void your warranty.

**ALL UNNUMBERED
ITEMS ARE INTERCHANGEABLE
WITH OPPOSITE SIDE**

332009B

F3554-250

ELECTRICAL ASSEMBLY

KEY#	PART#	DESCRIPTION	QTY
1	331450	WIRE HARNESS, SF, W/AMP	1
2	322298	SPLICER	1
3	57444	TIE, CABLE BLACK NYLON, 5.62 LONG	1
4	41482	PRESS CLIP, 1.380 LONG, .255 ID	2
5	303064	ASSEMBLY, LIGHT WIRE-1/4 TURN	1
6	52572	BULB, HEADLAMP	2
7	57444	TIE, CABLE BLACK NYLON, 5.62 LONG	1
8	41482	PRESS CLIP, 1.380 LONG, .255 ID	2
9	327355	SWITCH-IGN.(AFTER FIRE) 3 POSN	1
11	327352	NUT, 5/8-8ACME DELTA FOR BOOT	1
12	327350	KEY, IGNITION	1
13	300334	LIGHT SWITCH, ON/OFF PANEL MOUNT	1
14	57476	SWITCH, SCREW MOUNT, DP, NC, NO, BLK	2
15	300302	SCREW, #10 X .50 HHTAPPST, BLACK	4
17	53716	SOLENOID	1
18	187745	SCREW, 1/4-20 X .75 HXSEMMA	2
19	1084	WASHER, FLAT .281 X 1.00 X .063	1
20	1502	NUT, 1/4-20 REGHEXCTRLK	2
21	271172	NUT, 1/4-20 REGHEXKEPS	1
22	271187	NUT, 5/16-24 HKEPS	2
23	57444	TIE, CABLE BLACK NYLON, 5.62 LONG	1
24	55511	WIRE, GROUND, 12.5"	1
25	271184	NUT, 5/16-18 HEXKEPS	1
26	57547	SWITCH, SEAT	1
27	160505	SCREW, 1/4-20 X .38 PHPNHMA	2
28	92693	BATTERY, 12V	1
29	329175	BATTERY BRACKET	1
30	995346	SCREW, 1/4-20 X .50 WAHTAP	1
31	187745	SCREW, 1/4-20 X .75 HXSEMMA	1
32	1502	NUT, 1/4-20 REGHEXCTRLK	1
33	180020	SCREW, 1/4-20 X .75 HHC	2
34	271172	NUT, 1/4-20 REGHEXKEPS	2
35	302031	FUSE SPADE TYPE 32V 15A	1
36	9149	BRACKET, CABLE RETAINER	1
37	308201	INSULATOR, BATTERY BOOT EURO	1
38	124818	NUT, 1/4-20 REGHXJAM	1

SCHEMATIC DRAWING

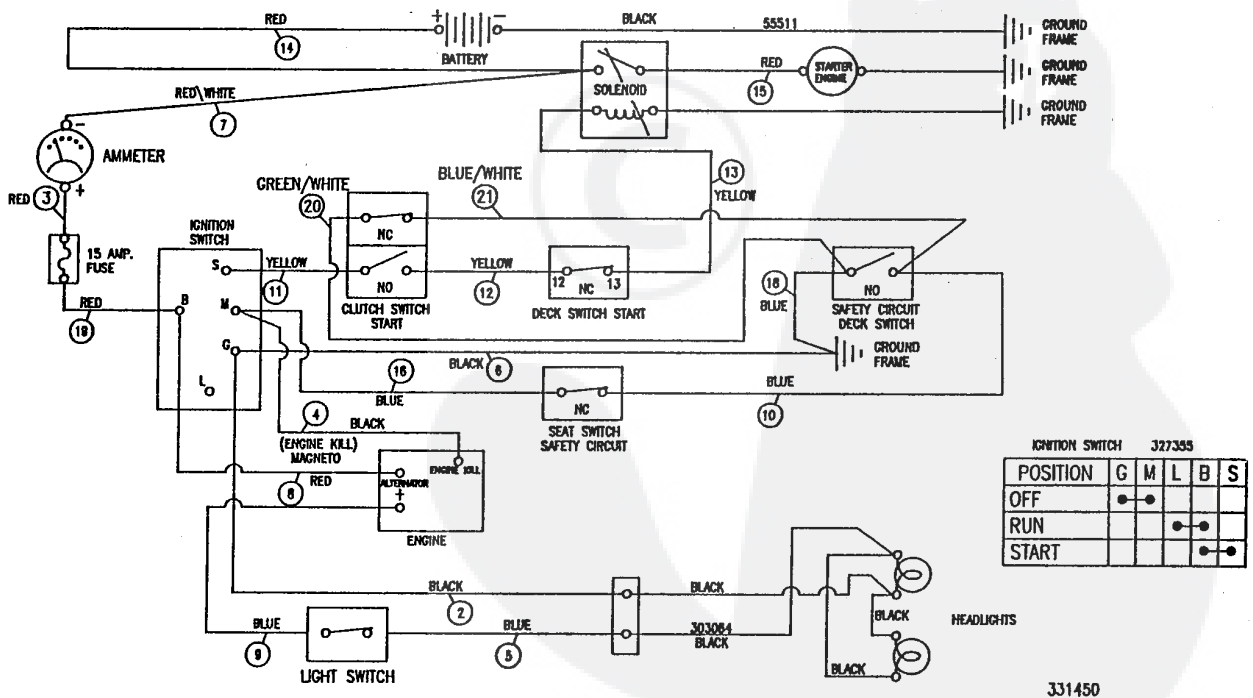

F3554-250

DECAL ASSEMBLY

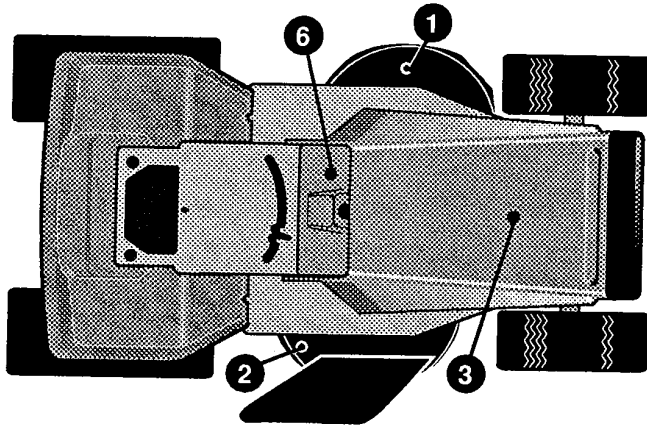
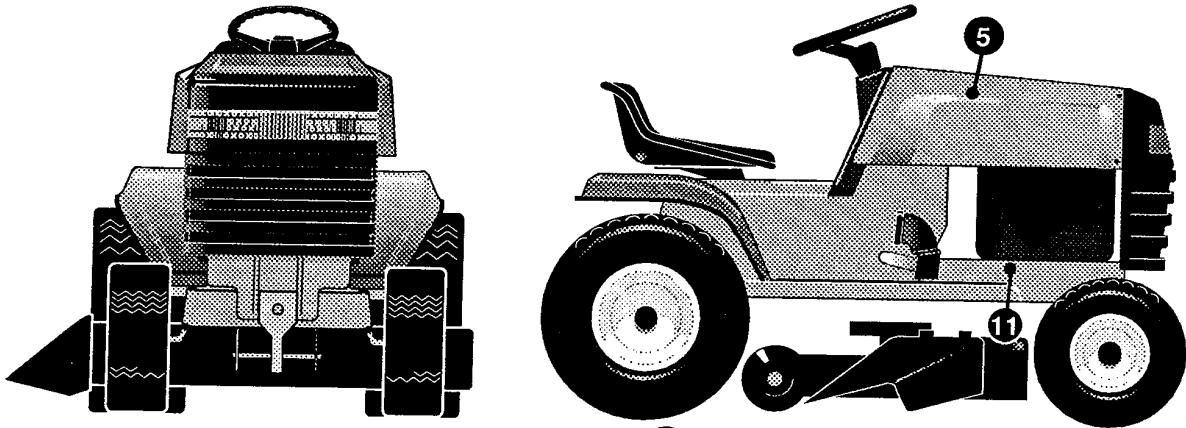

CONSOLE DETAIL

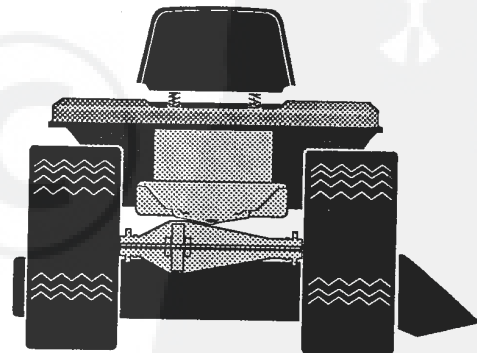
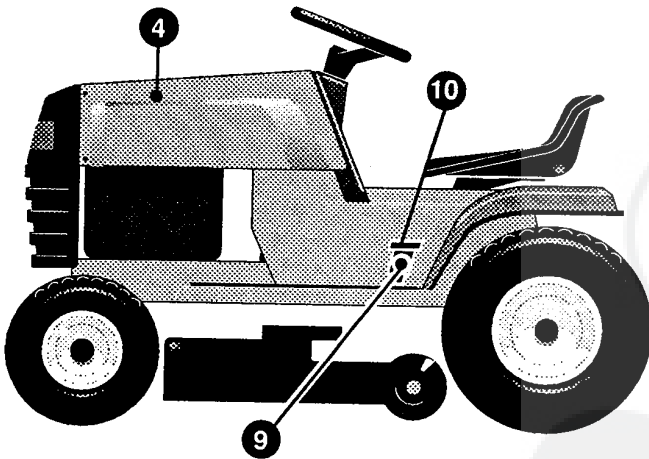
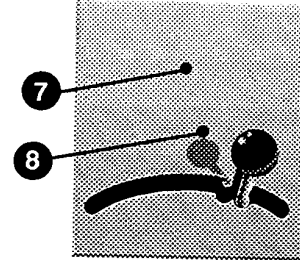

KEY#	PART#	DESCRIPTION	QTY
1	402700	DECAL, CAUTION DECK LH	1
2	402701	DECAL, CAUTION DECK RH CUT HND	1
3	55832	PAD, FOAM TOP HOOD	1
4	55833	PAD, FOAM HOOD H-4 SIDE LH	1
5	55834	PAD, FOAM HOOD H-4 SIDE RH	1
6	324989	DECAL DASH	1
7	402747	DECAL, CONSOLE SYMBOLIC	1
8	301104	DECAL, CONSOLE TOP SHIFT 5-SP	1
9	320892	DECAL, INSTR PEDAL LIFT	1
10	327146	DECAL, PEDAL-LIFT INDICATOR	1
11	402702	DECAL, BRAKE/CLUTCH	1

335247B

F3554-250

DECAL ASSEMBLY

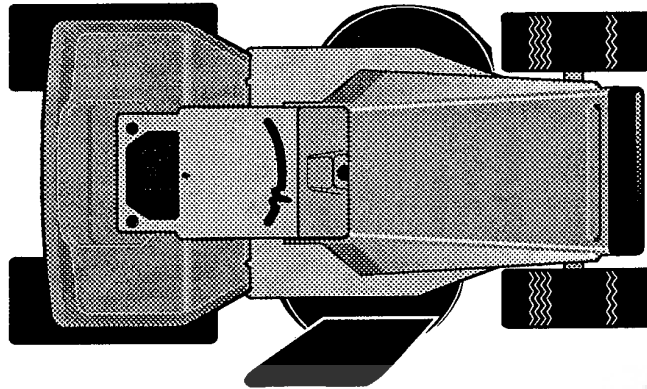
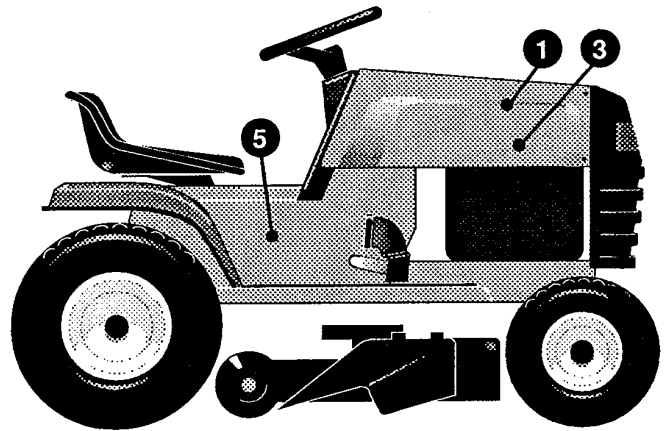
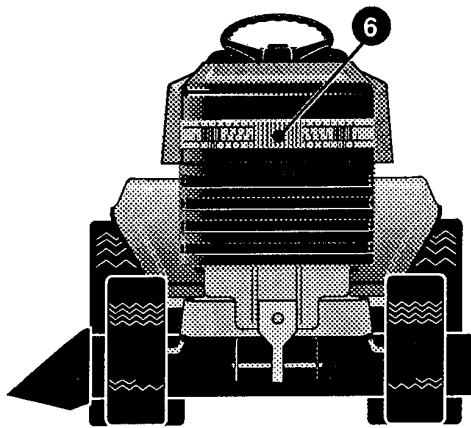

CONSOLE DETAIL

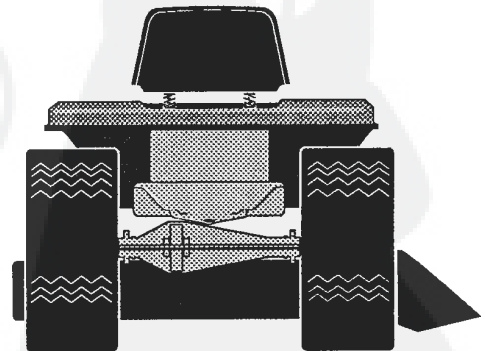
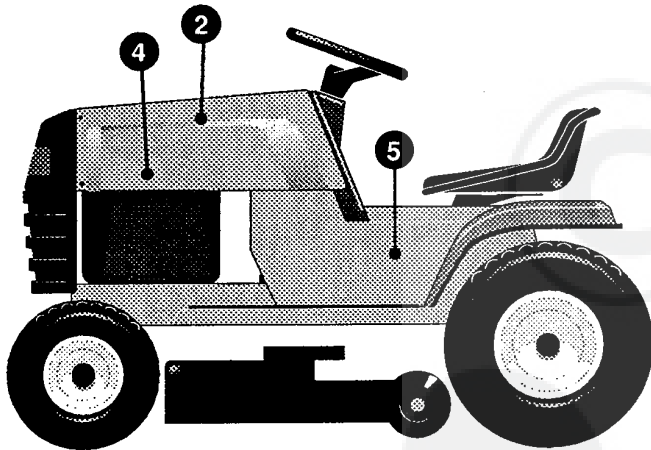
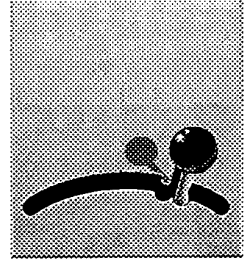

KEY#	PART#	DESCRIPTION	QTY
1	328754	DECAL, HOOD RH, LOUISIANE 1298	1
2	328753	DECAL, HOOD LH, LOUISIANE 1298	1
3	324318	DECAL, STRIPE RH, HOOD, LOUISIANE	1
4	324319	DECAL, STRIPE LH, HOOD, LOUISIANE	1
5	314208	NAMEPLATE, 12/38 WHITE	2
6	314948	FOIL, LENS REFLECTOR	1

335248A

F3554-250

CUSTOMER ASSEMBLY

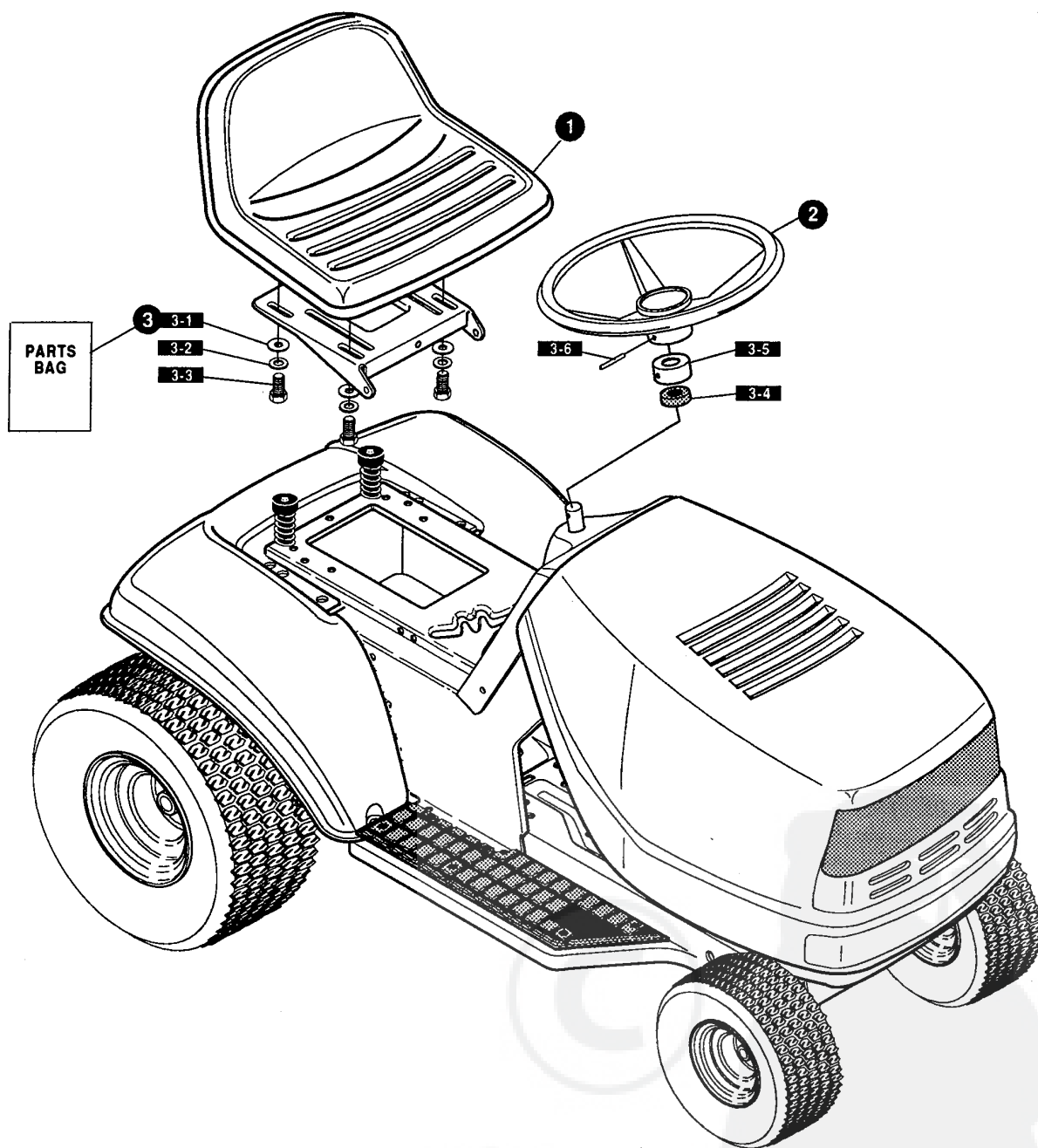

KEY#	PART#	DESCRIPTION	QTY
1	304314	SEAT, MICHIGAN W/SWITCH HOLE	1
2	330510	STEERING WHEEL.....	1
3		PARTS BAG, ASSEMBLY SEAT/STEER.....	1
3-1	120393	WASHER, FLAT .344 X .69 X .065.....	4
3-2	120638	WASHER, HVSPTLK .328 X .60 X .09.....	4
3-3	180077	SCREW, 5/16-18 X .75 HHC.....	4
3-4	331322	COVER, STEERING SHAFT.....	1
3-5	301413	SPACER, STEERING SHAFT.....	1
3-6	456378	PIN, SPRING .250 DIA X 2.00 LONG.....	1

327405 D

ACCESSORIES

Contact the dealer where your tractor was purchased for the available accessories. If you are unable to contact the dealer, write to the address on the warranty page of this manual.

Standard Lawn Tractor

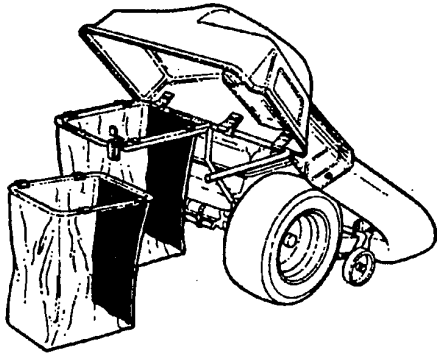

Model # 5708-13
Grass Collector for 39" decks
 For heavy duty grass collection
 order Model # 5709-10 Air Assist

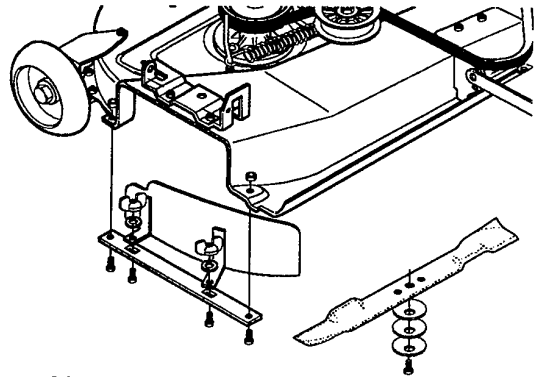

Model #5715-00
Mulching Kit (39" Deck)

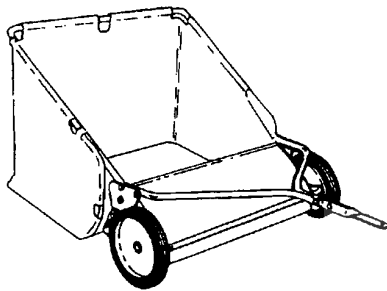

Model # 5648-16
Tow behind Lawn Sweeper for
Grass and leaves

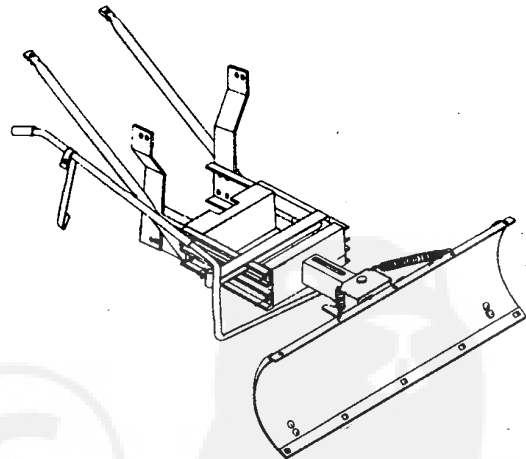

Model #5661-09
42" Snowblade - Fits 36", 38", 39", & 45"

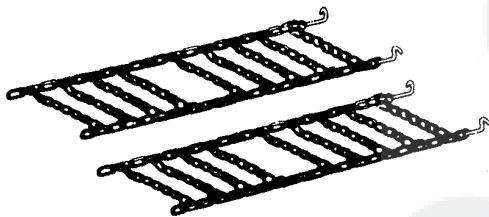

Model # 5579-00
Tire Chains - 18" x 8.50" tires

OTHER ACCESSORIES

Model	Description
5672-01	Wheel Weights - Front - 1 pr. w/mtg. hdw. - Fits 15" tires
5673-02	Wheel Weights - Rear - 1 pr. w/mtg. hdw. - Fits 18" & 20" tires
306932	39" High lift blade for bagging or side discharge (requires 2)
326160	39" Mulching blade (requires 2)