

# **GREENCUT**

## **MANUEL PIÈCES DE RECHANGE**



**TRACTEUR TONDEUSE 10/36**

**F3554- 390**

# F3554-380

# REPAIR PARTS

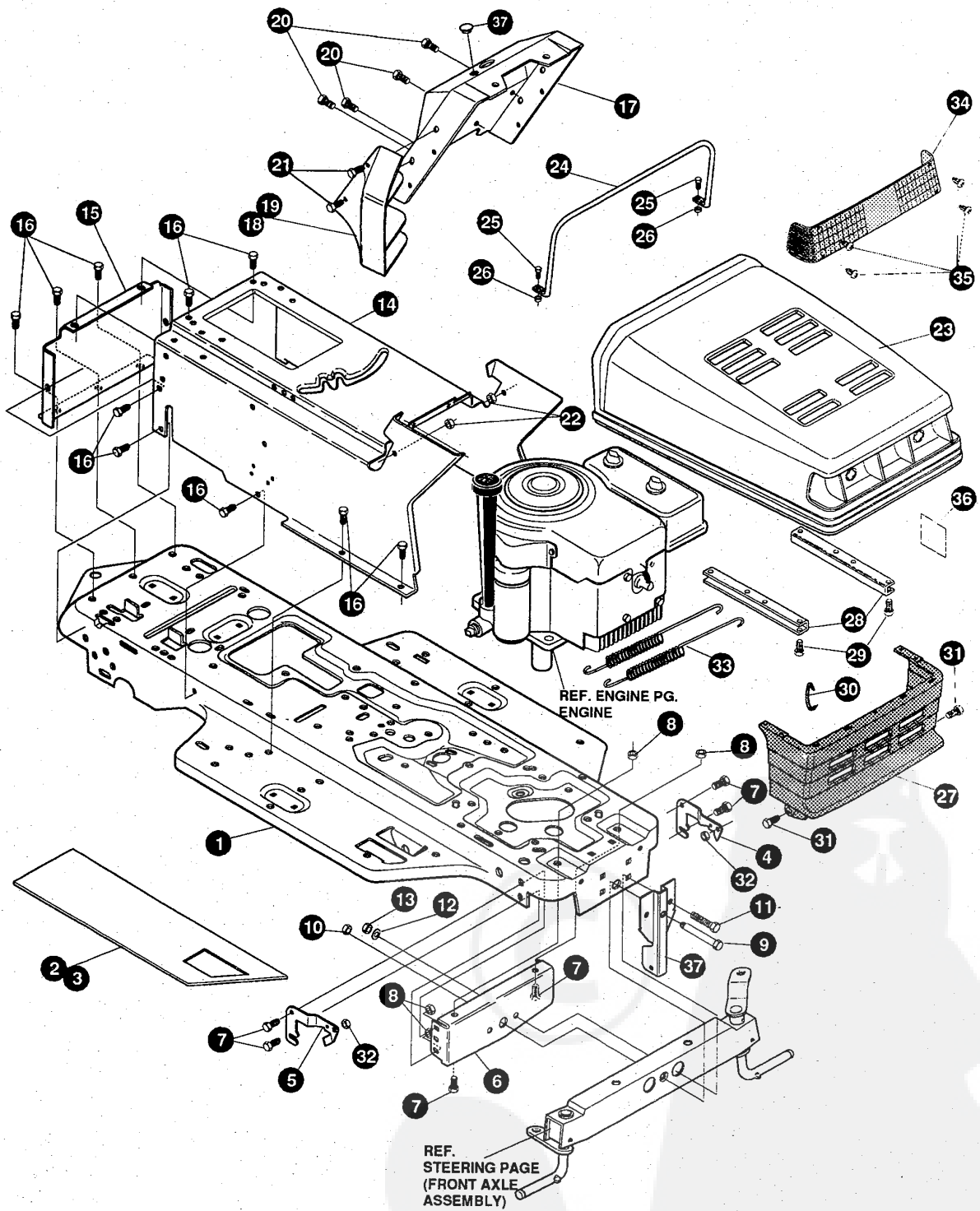

**NOTE: ALWAYS USE ORIGINAL EQUIPMENT PARTS.**  
Use of service/replacement parts other than original equipment parts may void your warranty.

**ALL UNNUMBERED ITEMS ARE INTERCHANGEABLE WITH OPPOSITE SIDE**

335945 A

# F3554-380

# CHASSIS & HOOD ASSEMBLY

KEY#	PART#	DESCRIPTION	QTY
1	331173-860	FRAME, MAIN, SF, RIDER.....	1
2	331834	FOOT PAD, RH, SF, FULL WIDTH.....	1
3	331835	FOOT PAD, LH, SF, FULL WIDTH.....	1
4	313003-853	BRACKET, GRILLE SUPPORT, LH.....	1
5	313004-853	BRACKET, GRILLE SUPPORT, RH.....	1
6	56362-853	BRACKET, SUPPORT, FRONT AXLE, SF.....	1
7	328154	SCREW, 5/16-18 X 1.0 WDFLLK.....	6
8	55273	NUT, 5/16-18 WDFLLKLRG, WHIZ.....	6
9	50720	BOLT, .625 X 2.875 SPSH, 1/2-20.....	1
10	274654	NUT, 1/2-20 REGHXCTRLK.....	1
11	180138	SCREW, 3/8-16 X 3.00 HHC.....	1
12	2483	WASHER, .39 ID X 1.25 D X .07 BELLVIL.....	1
13	1499	NUT, 3/8-16 REGHXCTRLK.....	1
14	332178-860	CONSOLE, SF, GP DASH.....	1
15	56235-860	CONSOLE, REAR COVER.....	1
16	995346	SCREW, 1/4-20 X .50 WAHTAP.....	15
17	321980-853	DASH, SF, W/O AMMET, GPWR.....	1
18	302723	INSERT, DASH, LH, 11HP.....	1
19	302724	INSERT, DASH, RH, 11HP.....	1
20	44811	SCREW, 1/4-20 X .75 WAHTAP.....	4
21	274672	SCREW, 1/4-20 X .63 WAHHC.....	4
22	51335	NUT, 1/4-20 WDFLWHIZ-LK.....	4
23	307032	HOOD, H-12, PLASTIC.....	1
24	307278	SUPPORT, HOOD, H-12, GP, 11HP.....	1
25	301542	SCREW, 10-24 X 1.00 HWATAP, BLACK.....	4
26	308459	NUT, #10-24 HXHDNYLK.....	4
27	302722	GRILL, G-15, GPWR, SMALL, LOWER.....	1
28	9783	BRACKET, TIE, HOOD.....	2
29	35055	SCREW, 10-24 X .50 SLHWATAP.....	8
30	310203	CLIP, HOG RING, C-SHAPED.....	1
31	56676	BOLT, .375 X .580 HSH, 5/16-18.....	2
32	1498	NUT, 5/16-18 REGHEXCTRLK.....	2
33	57478	SPRING, HOOD LATCH.....	2
34	305716	LENS, 11HP, HAKO, SMOKED, H-12.....	1
35	57796	SCREW, #6 X .50 PLASTITE/HI-LO.....	4
36	301452	FOIL, HEAT REFLECTOR.....	1
37	56261-860	BRACKET, FRONT HANGER.....	1
	318202	PLUG, DOME .56 DIA. HEYCO #2653, BLACK.....	1
	336330	PARTS MANUAL.....	1
	336354	OPERATOR'S MANUAL (FRENCH).....	1

# F3554-380

# REPAIR PARTS

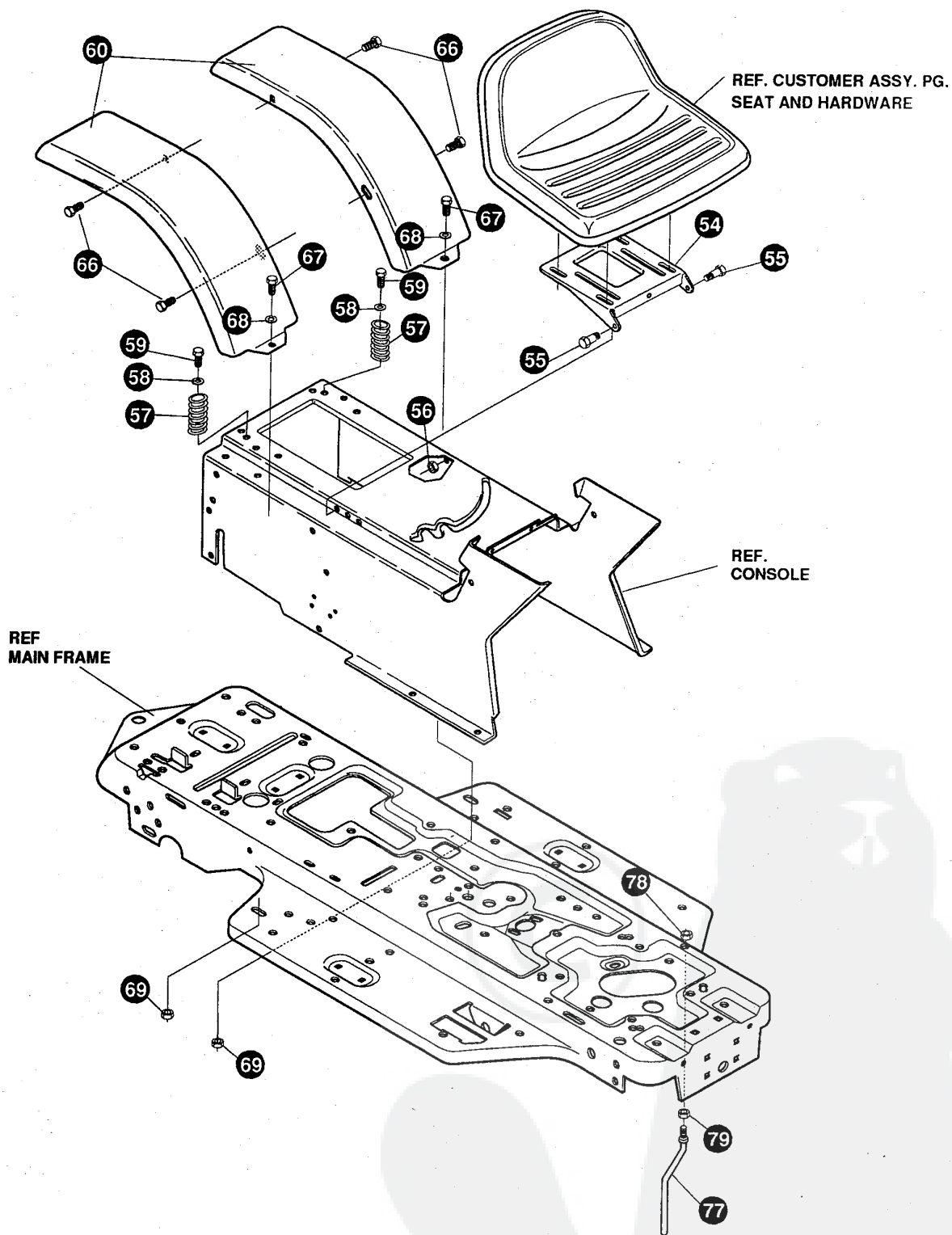

**NOTE: ALWAYS USE ORIGINAL EQUIPMENT PARTS.**  
Use of service/replacement parts other than original equipment parts may void your warranty.

**ALL UNNUMBERED ITEMS ARE INTERCHANGEABLE WITH OPPOSITE SIDE**

335945 A

**F3554-380**

**CHASSIS & HOOD ASSEMBLY**

KEY#	PART#	DESCRIPTION	QTY
54	58367-853	PLATE, SEAT, F5, SF, LF .....	1
55	20507	BOLT, 437 X .156 HSH, 5/16-18 .....	2
56	1498	NUT, 5/16-18 REGHEXCTRLK .....	2
57	330463	SPRING, SEAT 1.50 OD X 2.25 LONG .....	2
58	120392	WASHER, FLAT .281 X .63 X .065 .....	2
59	995346	SCREW, 1/4-20 X .50 WAHTAP .....	2
60	43970-860	FENDER F-1 .....	1
66	995346	SCREW, 1/4-20X .50 WAHTAP .....	4
67	126358	BOLT, 5/16-18 X 1.00 CARRLN .....	2
68	446363	WASHER, FLAT .375 X .88 X .082 .....	2
69	55273	NUT, 5/16-18 WDFLLKLRG, WHIZ .....	2
77	50653	GUIDE, BELT .....	1
78	41529	NUT, 3/8-16 HXCTRLKJAM .....	1
79	271190	NUT, 3/8-16 HEXKEPS .....	1

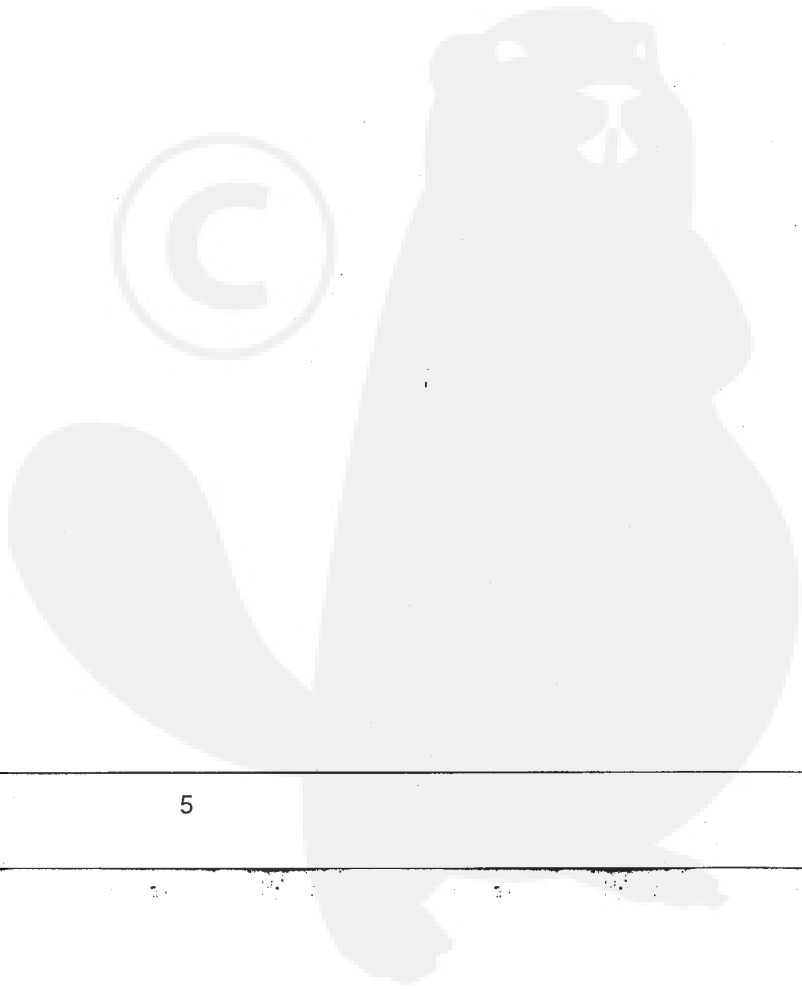
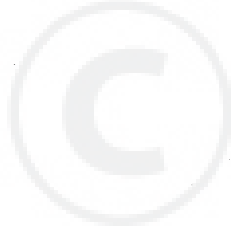

# F3554-380

# REPAIR PARTS

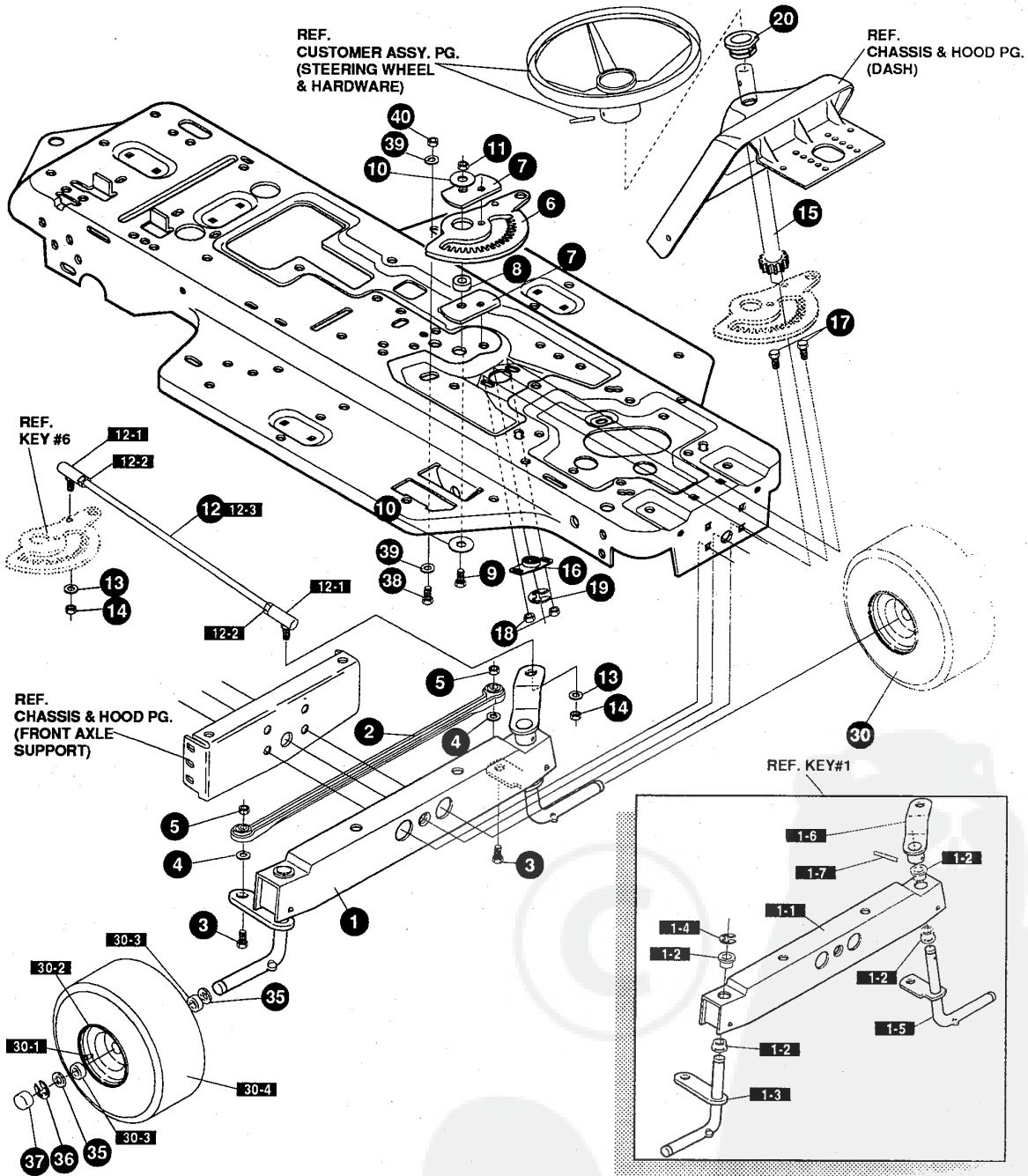

**NOTE: ALWAYS USE ORIGINAL EQUIPMENT PARTS.**  
 Use of service/replacement parts other than original equipment parts may void your warranty.

**ALL UNNUMBERED ITEMS ARE INTERCHANGEABLE WITH OPPOSITE SIDE**

332321 C

# F3554-380

# STEERING ASSEMBLY

KEY#	PART#	DESCRIPTION	QTY
1	*	AXLE FRONT ASSEMBLY, SF, LONG	1
1-1	312280	FRONT AXLE ASSEMBLY, SF, BLACK	1
1-2	50546	BEARING, FLANGE .759 ID X 1.002 OD X .75	4
1-3	310368	SPINDLE, ASSEMBLY, RH, LONG, SF	1
1-4	36625	RING, RETEX .57 X .05 TRU 5133-75	1
1-5	310367	SPINDLE ASSEMBLY, LH, LONG, SF	1
1-6	327619	ARM ASSEMBLY, SF, 4WS, FRONT STEERING	1
1-7	454565	PIN, SPRING .250 DIA X 1.25 LONG	1
2	302688	ASSEMBLY, TIE ROD, 19.31 LONG	1
3	180124	SCREW, 3/8-16X1.25 HHC	2
4	120382	WASHER, REGSPTLK .393 X .68 X .10	2
5	1499	NUT, 3/8-16 REGHXCTRLK	2
6	327399	GEAR, SECTOR, SF, 2WS	1
7	333289	PLATE SECTOR, SF, 4WS, BLACK	2
8	330021	BUSHING, SECTOR GEAR, SF, 4WS	1
9	181643	SCREW, 3/8-24 X 1.50 HHC	1
10	845	WASHER, FLAT .390 X 1.25 X .119	2
11	412349	NUT, 3/8-24 HXCTRLK	1
12	328808	DRAG LINK ASSEMBLY, 17.69 LONG	1
12-1	57158	BALL JOINT, 3/8 THD SHORT STUD	2
12-2	124925	NUT, 3/8-24 REGHEXJAM	2
12-3	56190	DRAG LINK	1
13	120382	WASHER, REGSPTLK .393 X .68 X .10	2
14	120369	NUT, 3/8-24 REGHEX	2
15	327395	SHAFT, PIN-STEER, BLACK	1
16	325692	BEARING, FLANGE .50 ID X 1.370 OD	1
17	326505	SCREW, 1/4-20 X .75 (TQ 30-35 FT#)	2
18	46931	NUT, 1/4-20 WDFL MAC-LOCK	2
19	20864	RING, RET E .39 X .04 TRU 5133-50	1
20	54902	BEARING, FLANGE .753 ID X 1.37 OD X .50	1
30	*	TIRE & RIM, PU 13 X 5.0 X 6	2
30-1	24167	VALVE STEM	
30-2	39937	RIM, WHEEL	
30-3	314416	BEARING, FLANGE	
30-4	319680	TIRE, 13 X 5 X 6	
35	642	WASHER, FLAT .755 X 1.31 X .075	4
36	36625	RING, RETEX .57 X .05 TRU 5133-75	2
37	40394	HUB CAP, 1.500 ID X 7/8 LONG	2
38	180124	SCREW, 3/8-16 X 1.25 HHC	1
39	120394	WASHER, FLAT .406 X .81 X .065	2
40	45171	NUT, 3/8-16 HWDFL WHIZ-LOCK	1

\* ORDER INDIVIDUAL PARTS - ASSEMBLY NOT AVAILABLE

# F3554-380

# REPAIR PARTS

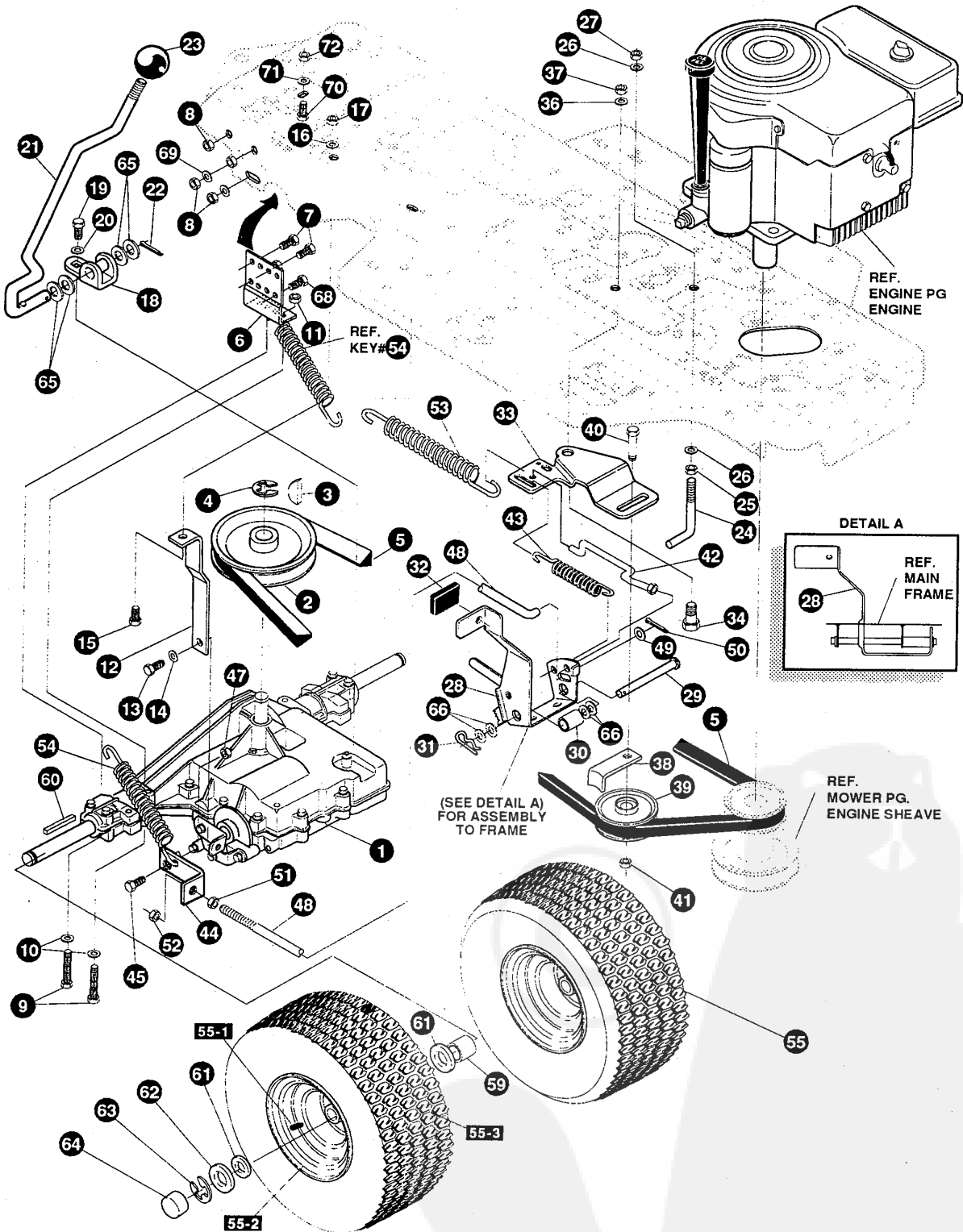

**NOTE: ALWAYS USE ORIGINAL EQUIPMENT PARTS.**  
Use of service/replacement parts other than original equipment parts may void your warranty.

ALL UNNUMBERED  
ITEMS ARE INTERCHANGEABLE  
WITH OPPOSITE SIDE

335693 B



# F3554-380

# MOTION DRIVE ASSEMBLY

KEY#	PART#	DESCRIPTION	QTY
1	*	TRANSAXLE, FOOTE, 4360-5	1
2	303109	PULLEY, 6.6 OD, V4L, T/A	1
3	50795	KEY, HI-PRO, 606 .75 DIA X .187 WD	1
4	22053	RING, RETEX .58 X .035 TRU 5100-62	1
5	54758	BELT, V 4L, 82.00, SF, DRIVE	1
6	326615-853	BRACKET, TRANSAXLE	2
7	180077	SCREW, 5/16-18 X .75 HHC	4
8	1498	NUT, 5/16-18 REGHEXCTRLK	8
9	180091	SCREW, 5/16-18 X 2.50 HHC	4
10	120393	WASHER, FLAT .344 X .69 X .065	4
11	1498	NUT, 5/16-18 REGHEXCTRLK	4
12	323126	BRACKET, STABILIZER, BLACK	1
13	35498	SCREW, 5/16-18 X .75 WAHHTAP	1
14	120638	WASHER, HVSPTLK .328 X .60 X .09	1
15	180079	SCREW, 5/16-18 X 1.00 HHC	1
16	138485	WASHER, EXLK .320 X .61 X .03	1
17	1498	NUT, 5/16-18 REGHEXCTRLK	1
18	331393	BRACKET, SHIFT, F4360	1
19	56255	SCREW, 1/4-28 X .75 NYLHHC	1
20	57157	WASHER, .750 X .250 SP-TRANSAXLE	1
21	331800	SHIFT LEVER (DANA)	1
22	137185	PIN, COTTER .125 DIA X 1.00 LONG	1
23	55514	KNOB, ROUND 1.50 DIA, BLACK	1
24	49896	BELT GUIDE	1
25	271184	NUT, 5/16-18 HEXKEPS	1
26	120393	WASHER, FLAT .344 X .69 X .065	2
27	1498	NUT, 5/16-18 REGHEXCTRLK	1
28	331836	ASSEMBLY, PEDAL, BRAKE, CLUTCH, SF	1
29	319676	PIN, CLEVIS .500 D X 4.87 LONG	1
30	331972	SPACER, SLEEVE .53 X .62 X 1.240	1
31	56180	PIN, HAIR .091 DIA X 1.62 LONG	1
32	48761	PAD, CLUTCH/BRAKE PEDAL	1
33	321969	IDLER ARM BRACKET, TRACTION, SF	1
34	329989	BOLT, .625 X .135 HSH, 5/16-18	1
36	45602	WASHER, FLAT .333 X .87 X .119	1
37	1498	NUT, 5/16-18 REGHEXCTRLK	1
38	39659	RETAINER, BELT	1
39	35374	PULLEY, IDLER, V4L, 3.06 X .62	1
40	45892	BOLT, 3/8-16 X 1.50 CARRSN	1
41	1499	NUT, 3/8-16 REGHXCTRLK	1
42	333175	CLUTCH ROD ASSEMBLY, .268 DIA 3.92	1
43	326780	SPRING, 3/8 OD X 2.18 X .055 TENSION	1
44	323127	BRACKET, BRAKE ROD BLACK	1
45	20507	BOLT, .437 X .156 HSH, 5/16-18	1
47	1498	NUT, 5/16-18 REGHEXCTRLK	1
48	323222	BRAKE ROD, RIDER, BLACK	1
49	120393	WASHER, FLAT .344 X .69 X .065	1
50	121222	PIN, COTTER .090 DIA X .75 LONG	1
51	271184	NUT, 5/16-18 HEXKEPS	1
52	44108	NUT, 5/16-18 HWDFLCTRLK	1
53	327867	SPRING, 3/4 OD X 7.75 X .091 TENSION	1
54	35410	SPRING, .071 X .62 X 4.37	1
55	^	TIRE & RIM, PU 18 X 6.5 X 8	2
55-1	24167	VALVE STEM	
55-2	36182	RIM, WHEEL	
55-3	42091	TIRE, 18 X 6.5 X 8	
59	57479	SPACER, SLEEVE .75 X 1.25 X 1.32	2
60	52928	KEY, SQUARE .187 SQUARE X 2.25 LONG	2
61	642	WASHER, FLAT .755 X 1.31 X .075	4
62	42815	WASHER, FLAT .755 X 1.53 X .07	2
63	36625	RING, RETEX .57 X .05 TRU 5133-75	2
64	40394	HUB CAP, 1.500 ID X 7/8 LONG	2
65	5950	WASHER, FLAT .505 X .88 X .13	4
66	2968	WASHER, FLAT .504 X .75 X .059	4
68	327917	SCREW, 5/16-18 X 1.50 HHCFT	4
69	73787	WASHER, FLAT .330 X .75 X .1793	4
70	180022	SCREW, 1/4-20 X 1.00 HHC	1
71	120380	WASHER, REGSPTLK .263 X .49 X .07	1
72	120375	NUT, 1/4-20 REGHEX	1

^ ORDER INDIVIDUAL PARTS - ASSEMBLY NOT AVAILABLE

\* CONTACT YOUR NEAREST TRANSAXLE DEALER FOR PARTS & SERVICE

# F3554-380

# REPAIR PARTS

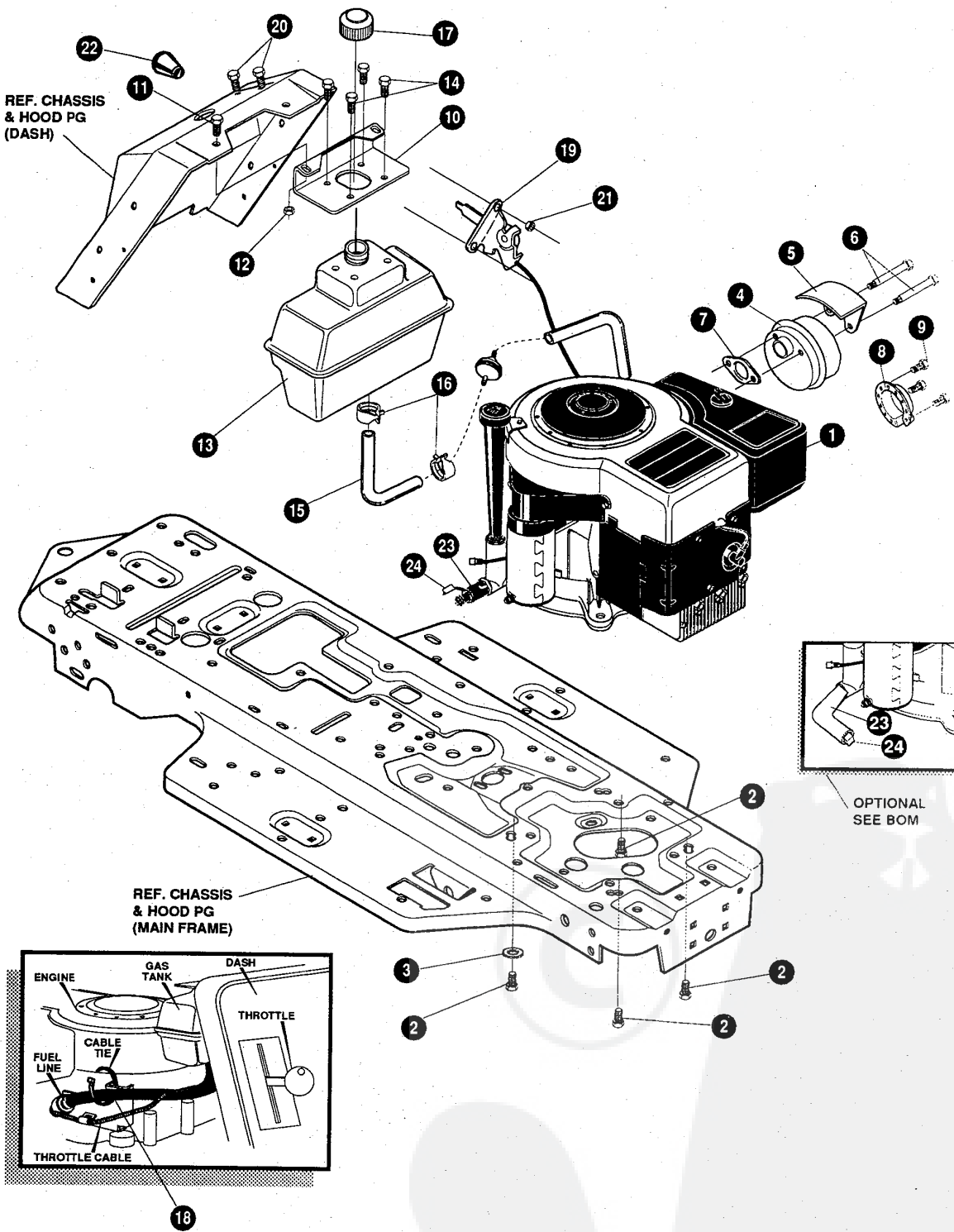

**NOTE: ALWAYS USE ORIGINAL EQUIPMENT PARTS.**  
Use of service/replacement parts other than original equipment parts may void your warranty.

**ALL UNNUMBERED  
ITEMS ARE INTERCHANGEABLE  
WITH OPPOSITE SIDE**

331631 C

**F3554-380****ENGINE & CONTROL ASSEMBLY**

KEY#	PART#	DESCRIPTION	QTY
1	*	ENGINE, 10-12HP, B&S, 3A .....	1
2	50947	SCREW, 3/8-16 X 1.25 WAHTAP .....	4
3	138489	WASHER, EXLK .384 X .69 X .04 .....	1
4	57908	MUFFLER-DOMESTIC/EXPORT ROUND .....	1
5	54767	SHIELD, HEAT, FOR ROUND MUFFLER .....	1
6	54980	SCREW, 5/16-18 X 3.50 HHC .....	2
7	46708	GASKET, MUFFLER .....	1
8	323423	DEFLECTOR, MUFFLER PARTIAL .....	1
9	35287	SCREW, #8-32 X .38 HHWATAP .....	3
10	302814-853	BRACKET, GAS TANK .....	1
11	180020	SCREW, 1/4-20 X .75 HHC .....	2
12	50352	NUT, 1/4-20 WDFLLK TOPLOCK .....	2
13	314989	TANK, FUEL 1 GALLON, CLEAR .....	1
14	300303	SCREW, .25 X .75 X .51 HHWAPLASTITE .....	4
15	41007	TUBING, .25 X .50 X BULK GAS LINE .....	15.0'
16	47345	CLAMP, HOSE SCREW TYPE .....	2
17	46704	CAP, GAS 1-1/2-7 THD, BLACK .....	1
18	57444	TIE, CABLE BLACK NYLON, 5.62 LONG .....	1
19	320031	THROTTLE CONTROL .....	1
20	274707	SCREW, 10-24 X .50 WAHMA .....	2
21	308459	NUT, #10-24 HXHDNYLK .....	2
22	50607	KNOB, ROUND THROTTLE, BLACK .....	1
23	325547	OIL DRAIN VALVE OR TUBE, GEN .....	1
24	327422	CAP OR PLUG FOR OIL DRAIN, GEN .....	1

\* SEE ENGINE MANUAL

# F3554-380

# REPAIR PARTS

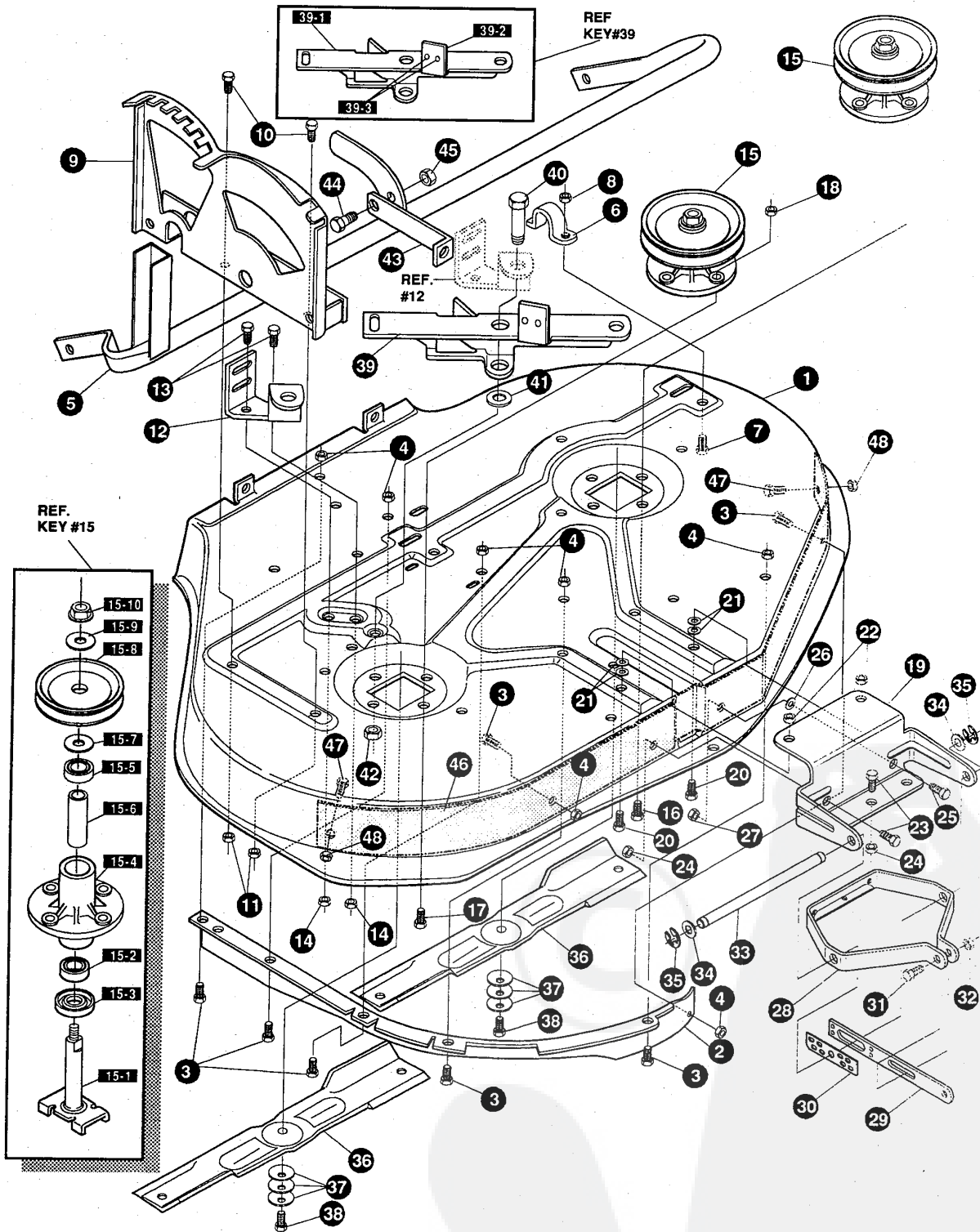

**NOTE: ALWAYS USE ORIGINAL EQUIPMENT PARTS.**  
 Use of service/replacement parts other than original equipment parts may void your warranty.

**ALL UNNUMBERED ITEMS ARE INTERCHANGEABLE WITH OPPOSITE SIDE**

335960 A

# F3554-380

# PRE-PAINTED DECK ASSEMBLY

KEY#	PART#	DESCRIPTION	QTY
1	325094	36" DECK KIT	1
2	310242	BAFFLE, 36 RD, LH, DECK, BLACK	1
3	180077	SCREW, 5/16-18 X .75 HHC	7
4	1498	NUT, 5/16-18 REGHEXCTRLK	7
5	304015	ASSEMBLY, TORQUE TUBE, 36"	1
6	310672	SUPPORT, PIVOT TUBE, BLACK	1
7	180073	SCREW, 5/16-18 X .50 HHC	1
8	1498	NUT, 5/16-18 REGHEXCTRLK	1
9	313630	32 & 36 QUADRANT, BLACK	1
10	180073	SCREW, 5/16-18 X .50 HHC	2
11	1498	NUT, 5/16-18 REGHEXCTRLK	2
12	313631	BRACKET, IDLER, BLACK	1
13	180077	SCREW, 5/16-18 X .75 HHC	2
14	1498	NUT, 5/16-18 REGHEXCTRLK	2
15	56424	QUILL ASSEMBLY, 36/39/40/43	2
15-1	56425	SHAFT/SADDLE, 36"	1
15-2	49562	BEARING, BALL 6203-2AA-C3 ARMORED	1
15-3	50616	DUST SHIELD	1
15-4	55547	QUILL CASTING (1046)	1
15-5	49562	BEARING, BALL 6203-2AA-C3 ARMORED	1
15-6	50818	SPACER, SLEEVE .669 X .88 X 3.797	1
15-7	51449	SPACER, SLEEVE .672 X .93 X .438	1
15-8	313898	PULLEY ASSEMBLY	1
15-9	56365	WASHER, SPECIAL QUILL	1
15-10	1282	NUT, 7/16-20 WDFLLK	1
16	35498	SCREW, 5/16-18 X .75 WAHHTAP	7
17	300345	SCREW, 5/16-18 X 1.38 WAHHTAP	1
18	1498	NUT, 5/16-18 REGHEXCTRLK	1
19	310762	LIFT PLATE, BLACK	1
20	180077	SCREW, 5/16-18 X .75 HHC	2
21	996416	WASHER, FLAT .391 X 1.00 X .125	4
22	1498	NUT, 5/16-18 REGHEXCTRLK	2
23	180077	SCREW, 5/16-18 X .75 HHC	2
24	1498	NUT, 5/16-18 REGHEXCTRLK	2
25	180079	SCREW, 5/16-18 X 1.00 HHC	1
26	996416	WASHER, FLAT .391 X 1.00 X .125	1
27	1498	NUT, 5/16-18 REGHEXCTRLK	1
28	310673	BRACKET, PIVOT, BLACK	1
29	310230	BAR, HITCH	1
30	310229	BRACKET, LOCK	1
31	180126	SCREW, 3/8-16 X 1.50 HHC	1
32	1499	NUT, 3/8-16 REGHXCTRLK	1
33	55724	PIN, PIVOT ROD .50 D X 7.55	1
34	996425	WASHER, FLAT .515 X .88 X .064	2
35	20864	RING, RET E .39 X .04 TRU 5133-50	2
36	8685	BLADE, 36" STD-LIFT 18, BLACK	2
37	2483	WASHER, .39 ID X 1.25 D X .07 BELLVIL	6
38	39573	SCREW, 3/8-24 X 1.00 NYLHHC	2
39	311427	IDLER, ASSEMBLY, PIVOT ARM	1
39-1	311425	PIVOT ARM, IDLER, 32"/36" RD	1
39-2	306973	BRAKE PAD - HARD-NF343 (X-31)	1
39-3	41601	RIVET, OVSET .187 DIA X .50 LONG	2
40	47516	BOLT, .500X1.950 HSSH 3/8-16	1
41	996416	WASHER, FLAT .391X1.00X.125	1
42	1499	NUT, 3/8-16 REGHXCTRLK	1
43	56597	CLEVIS 30"SD LIFT CABLE	1
44	8482	BOLT, .375X .156 HSSH, 5/16-18	1
45	309936	NUT, 5/16-18 HXCTRLKJAM	1
46	312222	BAFFLE, 36RD DECK, BLACK	1
47	180020	SCREW, 1/4-20X .75 HHC	2
48	1502	NUT, 1/4-20 REGHEXCTRLK	2

# F3554-380

# REPAIR PARTS

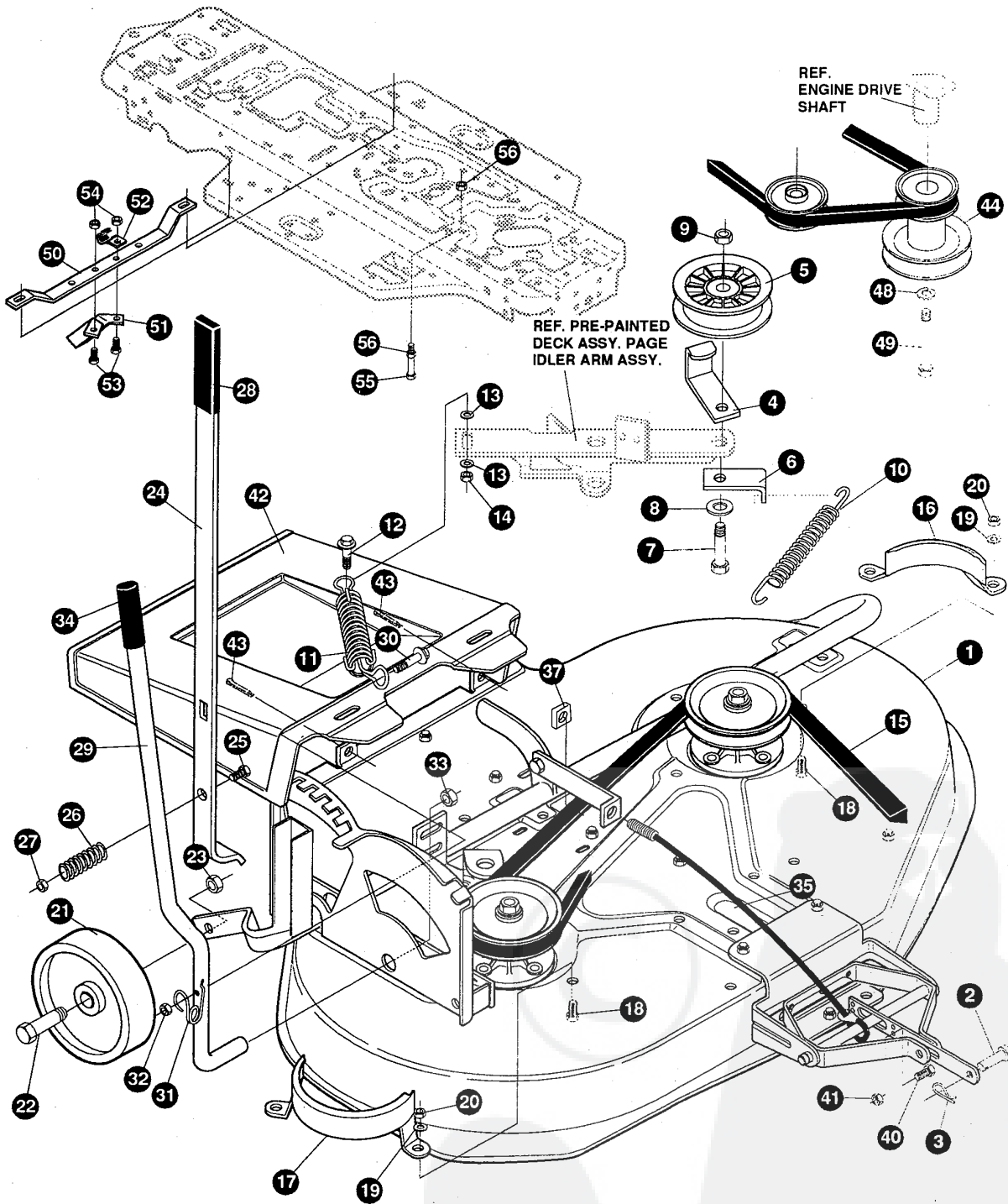

**NOTE: ALWAYS USE ORIGINAL EQUIPMENT PARTS.**  
Use of service/replacement parts other than original equipment parts may void your warranty.

**ALL UNNUMBERED  
ITEMS ARE INTERCHANGEABLE  
WITH OPPOSITE SIDE**

335964 A

# F3554-380

# FINAL DECK ASSEMBLY

KEY#	PART#	DESCRIPTION	QTY
1	13534	ASSEMBLY, MOWER, 36" RD, DECK	1
2	47817	PIN, CLEVIS LONG	1
3	56180	PIN, HAIR .091 DIA X 1.62 LONG	1
4	7354	RETAINER, BELT	1
5	303028	PULLEY, IDLER BFF, 3.13 DIA	1
6	57217-853	BRACKET, BRAKE ROD	1
7	180128	SCREW, 3/8-16 X 1.75 HHC	1
8	446363	WASHER, FLAT .375 X .88 X .082	1
9	1499	NUT, 3/8-16 REGHXCTRLK	1
10	35410	SPRING, .071 X .62 X 4.37	1
11	52636	SPRING	1
12	46563	BOLT, .375 X .250 SHWA, 1/4-20	1
13	120392	WASHER, FLAT .281 X .63 X .065	2
14	1502	NUT, 1/4-20 REGHEXCTRLK	1
15	308701	BELT, V 5L, 80.00, DECK, 36 RD, EXP	1
16	46365-853	COVER, QUILL, LH	1
17	46364-853	COVER, QUILL, RH	1
18	180077	SCREW, 5/16-18 X .75 HHC	4
19	120393	WASHER, FLAT .344 X .69 X .065	4
20	1498	NUT, 5/16-18 REGHEXCTRLK	4
21	302611	GAUGE WHEEL, EURO, 6.00 OD X 1.38 WD	2
22	23763	BOLT, .500 X 1.390 HSSH, 3/8-16	2
23	1499	NUT, 3/8-16 REGHXCTRLK	2
24	307050	LEVER, HEIGHT ADJUST	1
25	180091	SCREW, 5/16-18 X 2.50 HHC	1
26	53246	SPRING	1
27	1498	NUT, 5/16-18 REGHEXCTRLK	1
28	53995	GRIP, HAND	1
29	313632	LEVER, BLADE ENGAGE, BLACK	1
30	46563	BOLT, .375 X .250 SHWA, 1/4-20	1
31	46561	SPRING, TORSION 36 RD, 32 RD	1
32	1502	NUT, 1/4-20 REGHEXCTRLK	1
33	53697	NUT, 1/2 PUSHON	1
34	46478	GRIP, HAND .50 ID 3.37 LONG, BLACK	1
35	301718	CABLE, LIFT, 22.7 LONG, F-5, 20 X 10-8	1
37	120372	NUT, 1/4-20 REG SQ	1
40	180077	SCREW, 5/16-18 X .75 HHC	1
41	1498	NUT, 5/16-18 REGHEXCTRLK	1
42	50993	CHUTE, EXTENSION, PLASTIC, 36 RD, BLACK	1
43	120123	PIN, COTTER .125 DIA X 1.25 LONG	2
44	328028	PULLEY, ENGINE 3.0D X 4.0 LONG X 5.0D	1
48	120383	WASHER, REGSPTLK .459 X .78 X .12	1
49	433146	SCREW, 7/16-20 X 4.25 HHC, BLACK	1
50	323102	SUPPORT, GUIDE BLACK	1
51	323105	GUIDE, MOWER DECK, BLACK	1
52	57569	RETAINER, .31 ID X .62 X .03 WIRE	1
53	180079	SCREW, 5/16-18 X 1.00 HHC	2
54	1498	NUT, 5/16-18 REGHEXCTRLK	2
55	49930	SCREW, 3/8-16 X 7.50 HHC	1
56	1499	NUT, 3/8-16 REGHXCTRLK	2

# F3554-380

# REPAIR PARTS

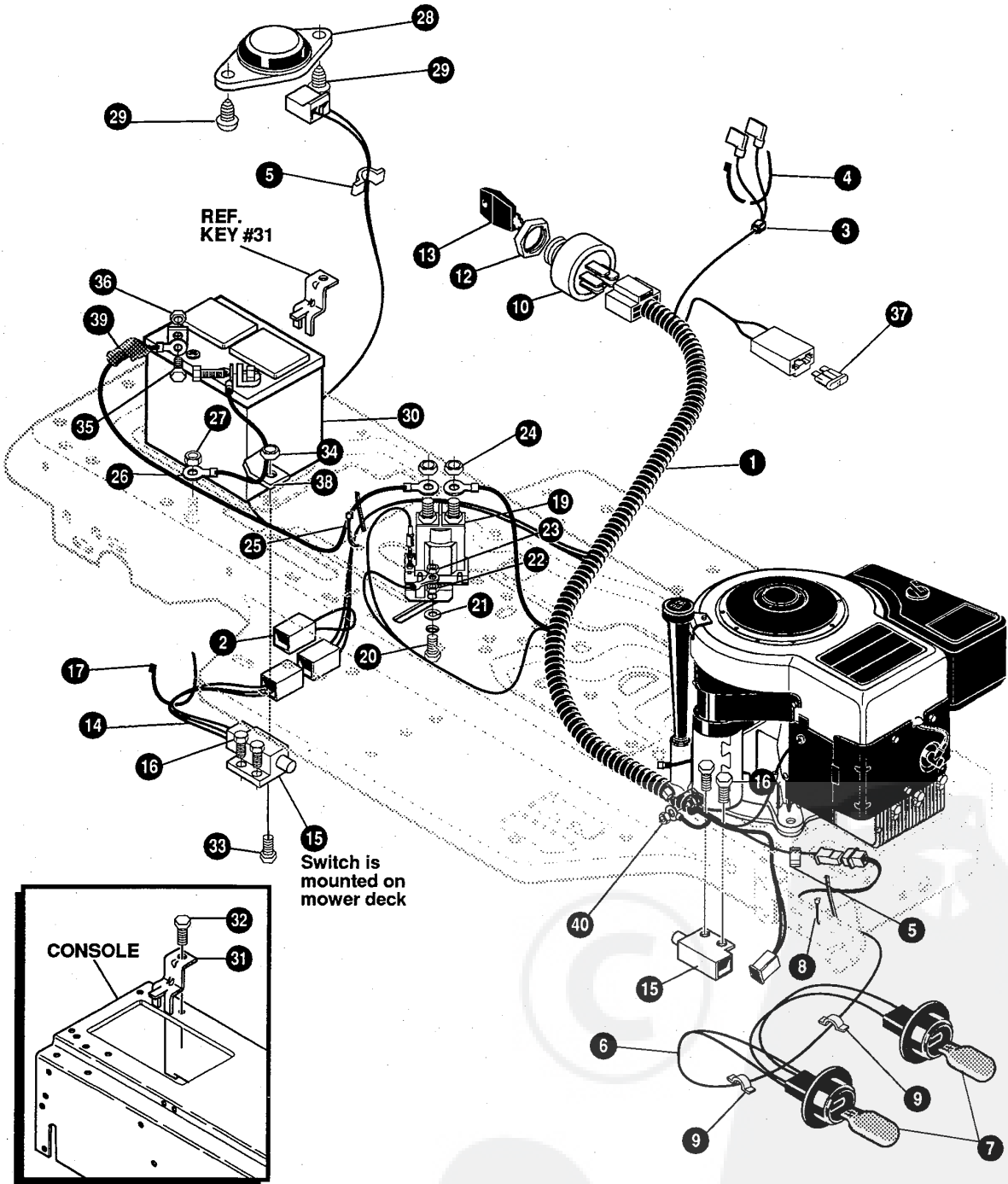

**NOTE: ALWAYS USE ORIGINAL EQUIPMENT PARTS.**  
 Use of service/replacement parts other than original equipment parts may void your warranty.

**ALL UNNUMBERED ITEMS ARE INTERCHANGEABLE WITH OPPOSITE SIDE**

331989 B



# F3554-380

# ELECTRICAL ASSEMBLY

KEY#	PART#	DESCRIPTION	QTY
1	331453	WIRE HARNESS, SF, 8-12HP, B&S, W/AMM	1
2	322296	BY-PASS FOR GROUND SUPPORT	1
3	322298	SPLICER	1
4	57444	TIE, CABLE BLACK NYLON, 5.62 LONG	1
5	41482	PRESS CLIP, 1.380 LONG .255 ID	2
6	303064	ASSEMBLY, LIGHT WIRE-1/4 TURN	1
7	52572	BULB, HEADLAMP	2
8	57444	TIE, CABLE BLACK NYLON, 5.62 LONG	1
9	41482	PRESS CLIP, 1.380 LONG .255 ID	2
10	327354	SWITCH, IGNITION & LIGHTS DELTA	1
12	327352	NUT, 5/8-8 ACME DELTA FOR BOOT	1
13	327350	KEY, IGNITION	1
14	57588	HARNESS, DECK WIRE SHORT, 4 WIRE	1
15	57476	SWITCH, SCREW MOUNT, DP, NC, NO BLACK	2
16	300302	SCREW, #10 X .50 HHTAPPST, BLACK	4
17	57444	TIE, CABLE BLACK NYLON, 5.62 LONG	1
19	53716	SOLENOID	1
20	187745	SCREW, 1/4-20 X .75 HXSEMMA	2
21	1084	WASHER, FLAT .281 X 1.00 X .063	1
22	1502	NUT, 1/4-20 REGHEXCTRLK	2
23	271172	NUT, 1/4-20 REGHEXKEPS	1
24	271187	NUT, 5/16-24 HKEPS	2
25	57444	TIE, CABLE BLACK NYLON, 5.62 LONG	1
26	55511	WIRE, GROUND, 12.5"	1
27	271184	NUT, 5/16-18 HEXKEPS	1
28	57547	SWITCH, SEAT	1
29	160505	SCREW, 1/4-20 X .38 PHPNHMA	2
30	92693	BATTERY, 12V (MAINTENANCE FREE)	1
31	329175	BATTERY BRACKET	1
32	995346	SCREW, 1/4-20 X .50 WAHHTAP	1
33	187745	SCREW, 1/4-20 X .75 HXSEMMA	1
34	1502	NUT, 1/4-20 REGHEXCTRLK	1
35	180020	SCREW, 1/4-20 X .75 HHC	2
36	271172	NUT, 1/4-20 REGHEXKEPS	2
37	302031	FUSE, SPADE TYPE 32V 15A	1
38	9149	CABLE RETAINING BRACKET	1
39	308201	INSULATOR, BATTERY BOOT EURO	1
40	124818	NUT, 1/4-20 REGHXJAM	1

## SCHEMATIC DRAWING

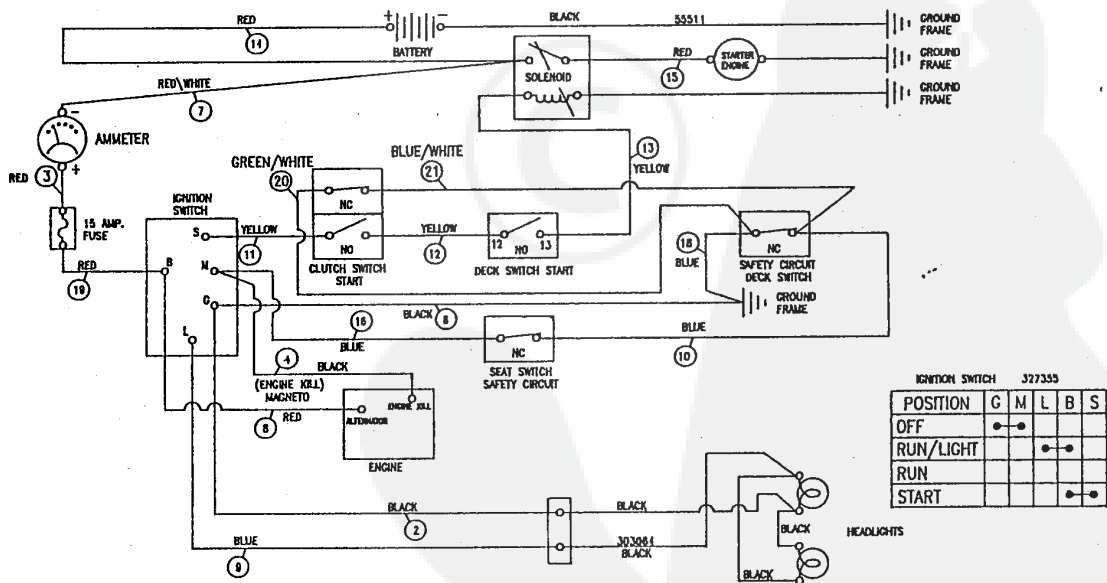

# F3554-380

# REPAIR PARTS

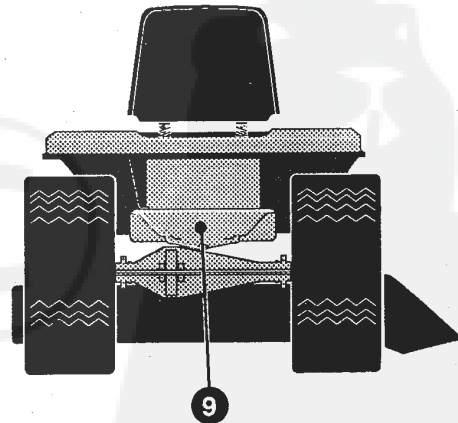
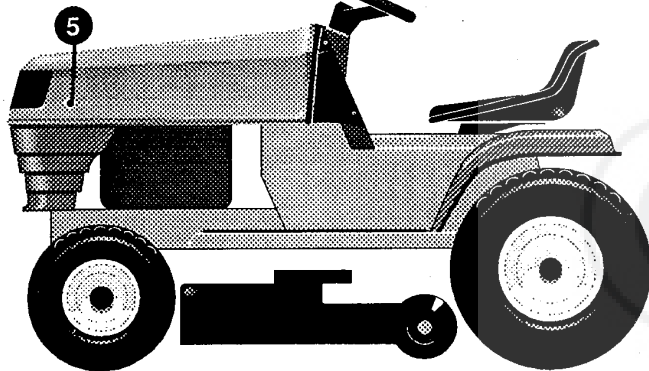
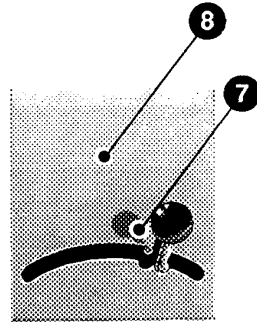
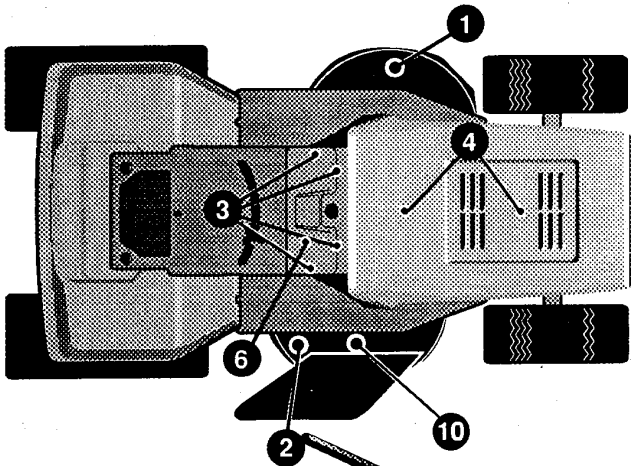
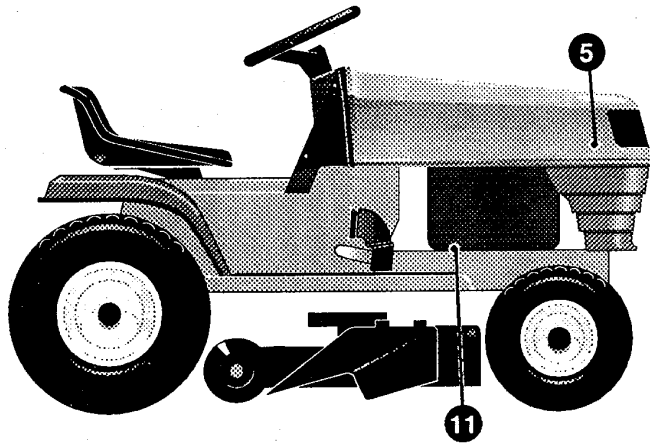
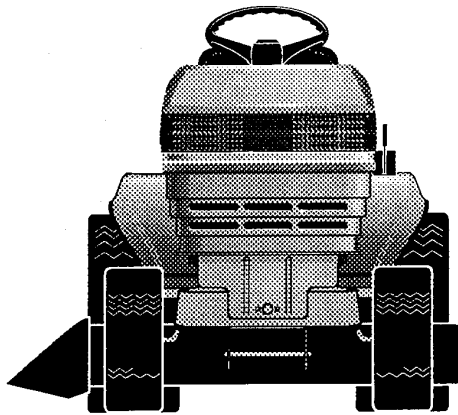

KEY#	PART#	DESCRIPTION	QTY
1	402700	DECAL, CAUTION, DECK, LH .....	1
2	402701	DECAL, CAUTION, DECK, RH .....	1
3	318197	PAD, ADHESIVE 1.00 X 1.50 X .12 .....	4
4	305602	FOAM, HOOD 4 X 15 .....	2
5	305603	PAD, 18 X 6 FOAM HOOD .....	2
6	320721	DECAL, DASH, PLAIN, EXPORT, G.P. ....	1
7	301104	DECAL, CONSOLE, TOP, SHIFT 5-SP .....	1
8	402747	DECAL, CONSOLE SYMBOLIC CAUTION .....	1
9	402701	DECAL, CAUTION, DECK, RH .....	1
10	402708	DECAL, BLADE, CUT HEIGHT/ENGAGE .....	1
11	402702	DECAL, BRAKE/CLUTCH .....	1

335710 B

# F3554-380

# DECAL ASSEMBLY

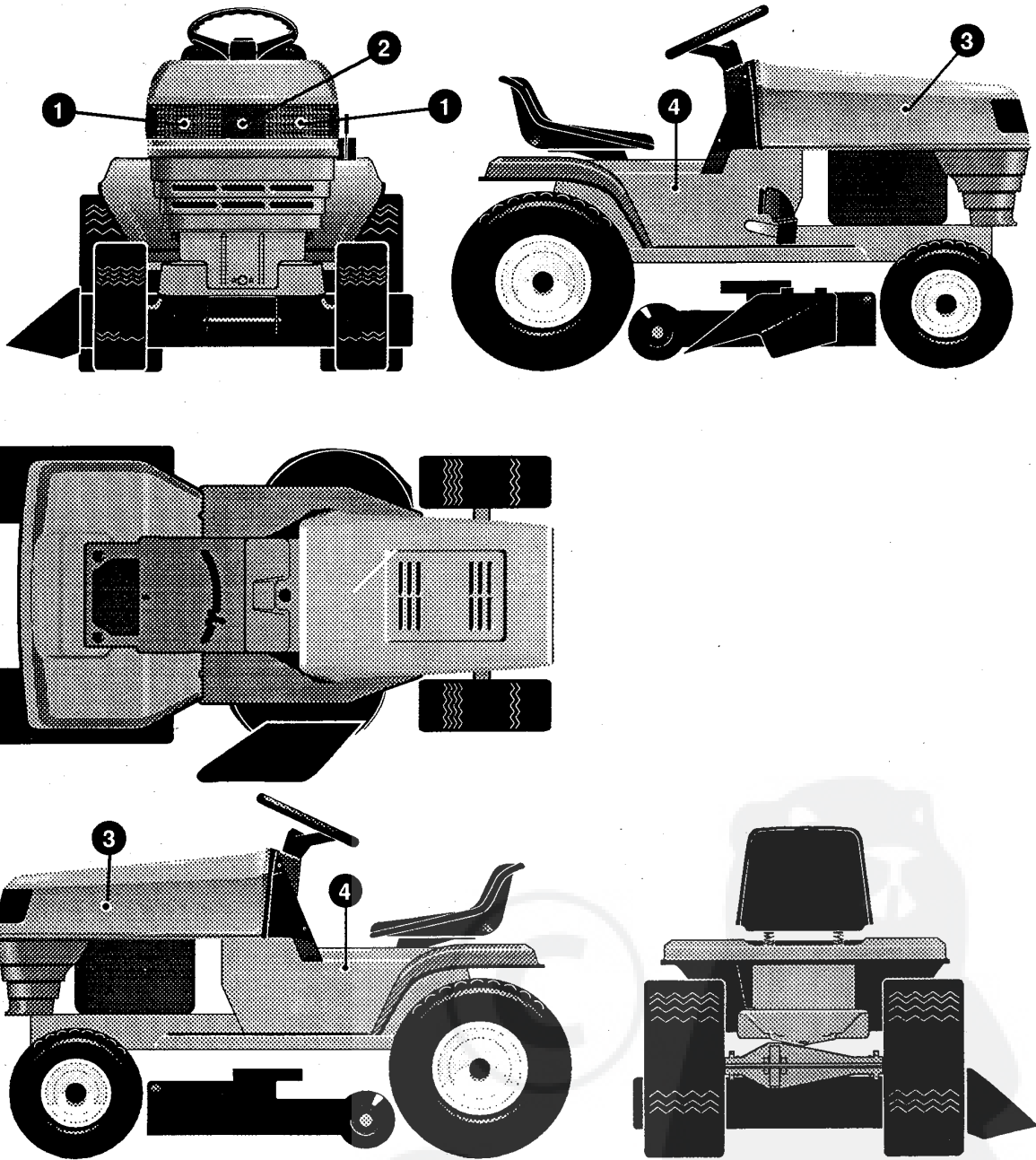

KEY#	PART#	DESCRIPTION	QTY
1	304979	FOIL, REFLECTOR LENS- BULB .....	2
2	307732	DECAL, LENS CENTER SMOKED .....	1
3	402676	DECAL, HOOD PRIM .....	2
4	402677	DECAL, CONSOLE PRIM 10.92 .....	2

335947 A