

NOTE: ALWAYS use ORIGINAL EQUIPMENT PARTS.
Use of service/replacement parts other than original equipment parts may void your warranty

ALL UNNUMBERED ITEMS ARE INTERCHANGEABLE WITH OPPOSITE SIDE

325864 C

KEY#	PART#	DESCRIPTION	QTY
1	326568-853	BRACKET, GRILLE RH	
2	326569 853	BRACKET GRILLE LH	
3	313541-853	BRACKET FRONT AXLE	1
4	56030	SCREW 5/16 18 X 75 WDFLLK	5
5	55273	NUT 5/16-18 WDFLLK LRG WHIZ	5
6	300440	GUIDE, BELT RIDER	
7	1498	NUT, 5/16-18 REGHEXCTRLK	
8	308207	BOLT. 625 X 2 18 HSH. 1-2 13	
9	309508	NUT, 1/2 13 HEXJAM CTRLK	
10	180138	SCREW 3/8-16 X 3 00 HHC	2
11	2483	WASHER 39 ID X 125 D X 07 BELLVIL	2
12	1499	NUT 38 16 REGHXCTRLK	2
13	300635	GUIDE BELT, SHORT 15" WHEEL	
14	124824	NUT 5/16 18 HEXJAM	
15	271190	NUT 3/8-16 HEXKEPS	
16	46763	RIVET POP 187 DIA X 450 LONG	3
17	35497	SCREW 5-16 18 X 50 WAHTAP	2
18	9 9 5 3 4 6	SCREW 1/4 20 X 50 WAHTAP	10
19	309447 860	DASH STEEL, LF SUSP	
20	995346	SCREW 1 4 20 X 50 WAHTAP	4
21	44811	SCREW 1 4 20 X 75 WAHTAP	4
22	50352	NUT 1 4 20 WDFLLK TOPLOCK	4
23	313021-853	GUIDE HOOD. SF & LF H13H14H15	1
25	51335	NUT 1/4-20 WDFLWHIZ LK	1
26	321159	HOOD NOMA LARGE H-15 GREY	
27	319986	DECAL TAPE H15.8 MIL VINYL	
28	302670	LENS HEADLAMP DYNA HOODS	
30	56676	BOLT 375 X 580 HSH 5/16 18	2
31	1498	NUT. 5/16-18 REGHEXCTRLK	2
32	310749	LANYARD HOOD 9 16 LONG H14	
33	180020	SCREW, 1/4-20 X 75 HHC	
34	120380	WASHER REGSPTLK 263 X 49 X 07	
35	49050	SCREW. 1/4 10 X 75 PHPNTAP	
36	301452	FOIL HEAT REFLECTOR	1
37	311465	COVER STEERING SHAFT	
38	330877	STEERING WHEEL	
39	301413	SPACER STEERING SHAFT	
40	456378	PIN SPRING 250 DIA X 2 00 LONG	
41	308492	FOIL LENS DYNA HOOD REFLECTOR	
	336055	PARTSMANUAL	
	335 154	OPERATOR'S MANUAL (ENGLISH)	
	3. 35155	OPERATOR'S MANUAL (FRENCH)	
	335156	OPERATOR'S MANUAL (GERMAN)	
	327627	GRASS CATCHER MANUAL	
	328195	AIR ASSIST MANUAL (ENGLISH)	
	330272	AIR ASSIST MANUAL (FRENCH)	
	330273	AIR ASSIST MANUAL (GERMAN)	

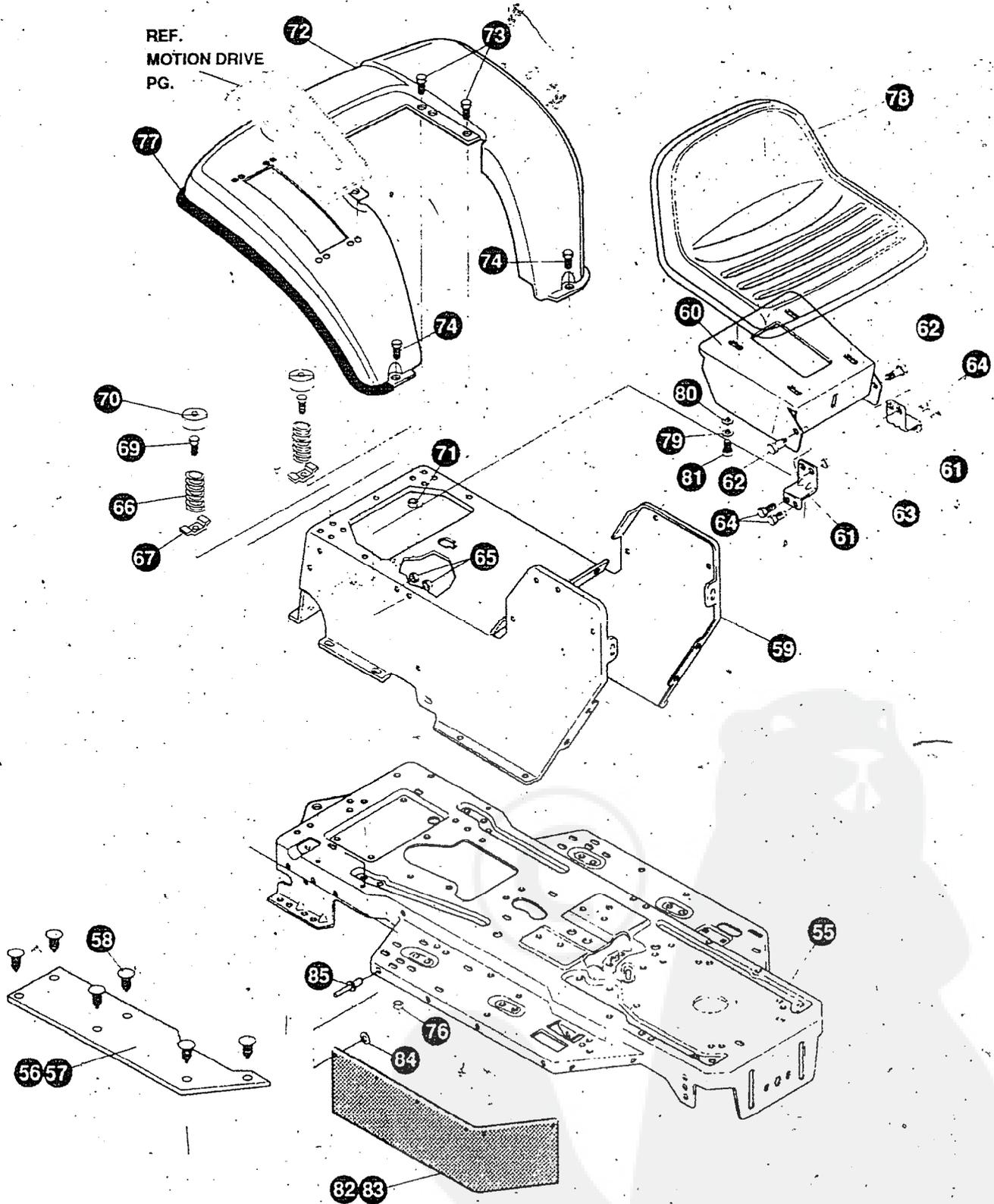

NOTE: ALWAYS USE ORIGINAL EQUIPMENT PARTS
Use of service/replacement parts other than original equipment parts may void your warranty

ALL UNNUMBERED
ITEMS ARE INTERCHANGABLE
WITH OPPOSITE SIDE

335406 B

KEY#	PART#	DESCRIPTION	QTY
55	326579-860	FRAME, LF, DRILLED, P920/F4360	1
56	314799	FOOT PAD, LH, "P-LIFT", DYNA, F-5	1
57	310006	FOOT PAD, RH, 22 12 LONG, DYNA, F-5	1
58	309235	FASTENER, RATCHET BLACK	12
59	315120-860	CONSOLE, DYNA LF SOF, P-LIFT	1
60	5822 1-860	PLATE, SEAT, LF, F4, F5-SOG	1
61	53746-860	BRACKET, SEAT SUPPORT, F4, F5-SOG	2
62	20507	BOLT, 437 X 156 HSH, 5/16- 18	2
63	1498	NUT, 5/16-18 REGHEXCTRLK	2
64	48901	SCREW, 5/16-18 X 63 WAHHC	4
65	1498	NUT, 5/16-18 REGHEXCTRLK	4
66	49335	SPRING, .250 X 1 75 X 4 50	2
67	7 6 8 6	CLAMP, SPRING	2
69	44811	SCREW, 1/4-20 X .75 WAHTAP	2
70	53265	COVER, SEAT SPRING, 2 25 ID	2
71	1 5 0 2	NUT, 1/4-20 REGHEXCTRLK	2
72	332186-860	FENDER, F5, LF, SOF, P-LIFT, GS	4
73	995346	SCREW, 1/4-20 X .50 WAHTAP	2
74	126358	BOLT, 5/16-18 X 1.00 CARRLN	2
76	55273	NUT, 5/16-18 WDFLLKLRG WHIZ	2
77	5 5 0 2 3	TRIM, STRIP, BLACK--SMALL W/ A D H	77 5
78	310384	SEAT, MICHIGAN GEN, W/SWITCH HOLE	1
79	120393	WASHER, FLAT .344 X 69 X 065	4
80	120638	WASHER, HVSPTLK 328 X 60 X 09	4
81	180077	SCREW, 5/16-18 X .75 HHC	4
82	3 0 5 3 8 6	SKIRT, TUV, LF, RUBBER, 7 X 28.03	1
83	305354	SKIRT, TUV, LF, RUBBER, 7 X 15 64	1
84	1501	WASHER, FLAT 203 X 56 X .040	10
85	329238	RIVET, POP 3/16 DIA X 75 LONG	10

REF.
CHASSIS & HOOD PG.
(STEERING WHEEL
& HARDWARE)

REF.
CHASSIS & HOOD PG
(DASH)

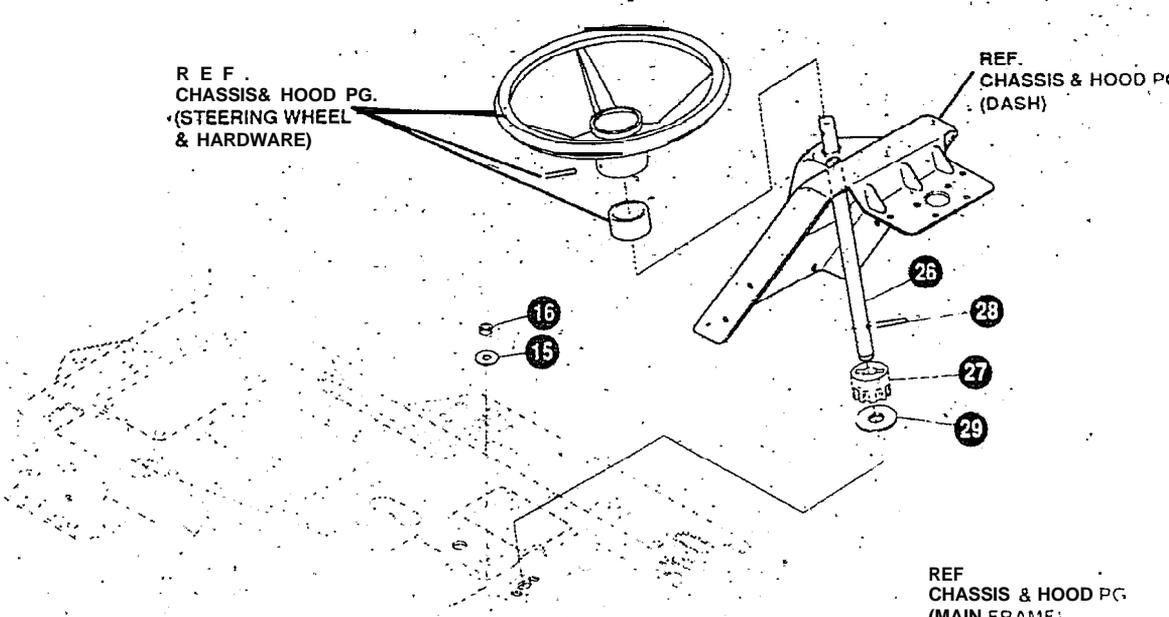

REF
CHASSIS & HOOD PG
(MAIN FRAME)

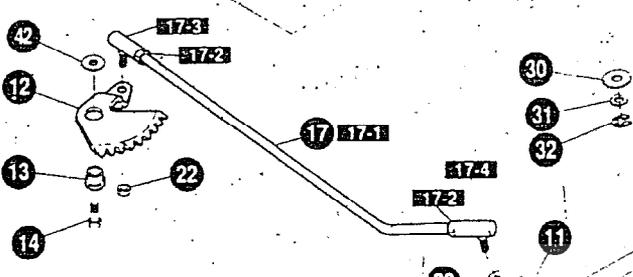

REF
CHASSIS & HOOD PG.
(FRONT AXLE
SUPPORT)

REF. KEY#1

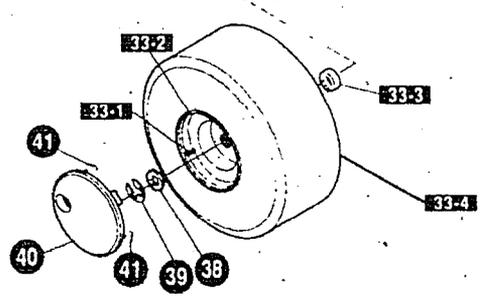
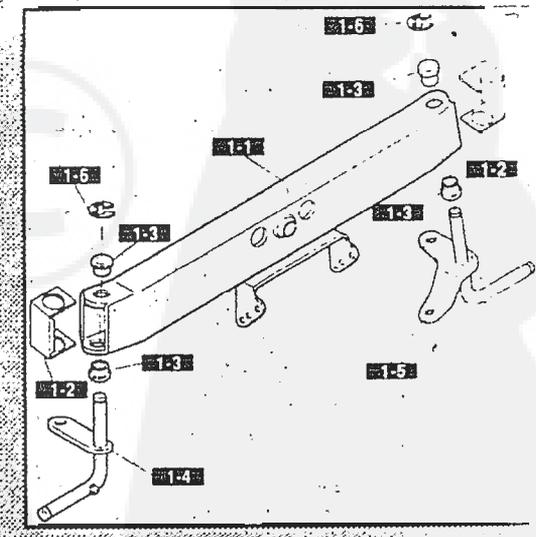
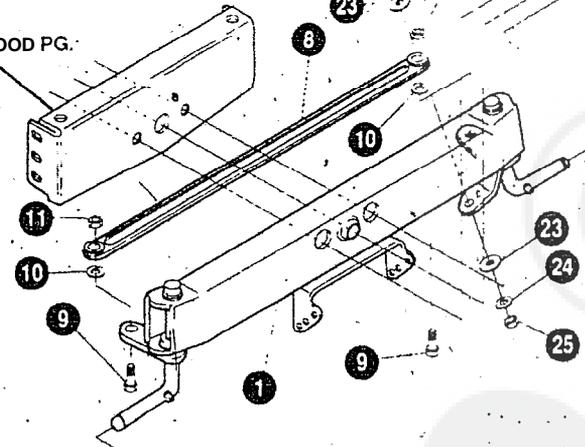

NOTE: ALWAYS USE ORIGINAL EQUIPMENT PARTS.
Use of service/replacement parts other than original
equipment parts may void your warranty.

ALL UNNUMBERED
ITEMS ARE INTERCHANGEABLE
WITH OPPOSITE SIDE

324171 E

KEY#	PART#	DESCRIPTION	QTY
		ASSEMBLY, AXLE FRONT, 4/WS -SUSP	1
1-1	310170	AXLE, FRONT	1
1-2	53373	AXLE COVER	2
1-3	52407	SPINDLE BEARING	4
1-4	302926	ASSEMBLY, SPINDLE, RH	1
1-5	315886	ASSEMBLY, SPINDLE, LH	1
1-6	36625	RING, RETEX 57 X 05 TRU 5133-75	2
8	304590	TIE ROD ASSEMBLY, 19.81 LONG, W-SECTION	1
9	180128	SCREW, 3/8-16 X 1 75 HHC	2
10	120382	WASHER, REGSPTLK 393 X 68 X 10	2
11	14999	NUT, 3/8-16 REGHXCTRLK	2
12	58289	SECTOR, STEERING, LF	1
13	52406"	BEARING, FLANGE, ECC 510 IO X 998 OD X 56	1
14	180177	SCREW, 1/2-13 X 1.50 HHC	1
15	22265	WASHER, FLAT 515 X 138 X 119	1
16	1500	NUT, 1/2-13 REGHXCTRLK	1
17	311100	KIT 300146 DRAGLINK	1
17-1	58291	STEERING LINK	1
17-2	124925	NUT, 3/8-24 REGHEXJAM	2
17-3	57158	BALL JOINT, 3/8 THD, SHORT STUD	1
17-4	21275	BALL JOINT, 3/8 THD, LONG STUD	1
2 2	46692	NUT, 3/8-24 WDFLHLK WHIZ	1
2 3	996416	WASHER, FLAT 391 X 1.00 X 125	2
2 4	120382	WASHER, REGSPTLK 393 X 68 X 10	1
2 5	120369	NUT, 3/8-24 REGHEX	1
-26	58243	SHAFT, STEERING, LF, 2WS	1
27	58244	PINION, STEERING, LF	1
28	58274	PIN, DOWEL 2500 OD+1.75 LONG	1
-29	301410	BEARING, FLANGE 752 ID X 1.061 OD X 24	1
30	301398	WASHER, FORMED 1 135 X 1 53 X 12	1
31	21682	WASHER, FLAT 765 X 125 X 042	1
32	36625	RING, RETEX 57 X .05 TRU 5133-75	1
33		TIRE & RIM, PU 15 X 60 X 6	2
33-1	24167	VALVE STEM	
33-2	321516	RIM, WHEEL	
33-3	314416	BEARING, FLANGE	
33-4	TIRE	REFER TO TIRE TREAD PAGE	
3 8	642	WASHER, FLAT 755 X 1.31 X 075	4
3 9	36625	RING, RETEX 57 X 05 TRU 5133-75	2
40	304444	HUB CAP, 6", EURO, GREY 630	2
41	306669	CLIP, HUBCAP TINN #C25467-017-4	8
42	49998	WASHER, FIAT 520 X 1.25 X 209	1

ORDER INDIVIDUAL PARTS ASSEMBLY NOT AVAILABLE

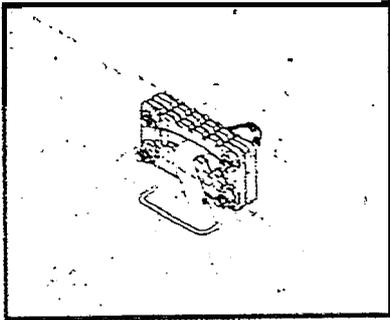

DETAIL "A"

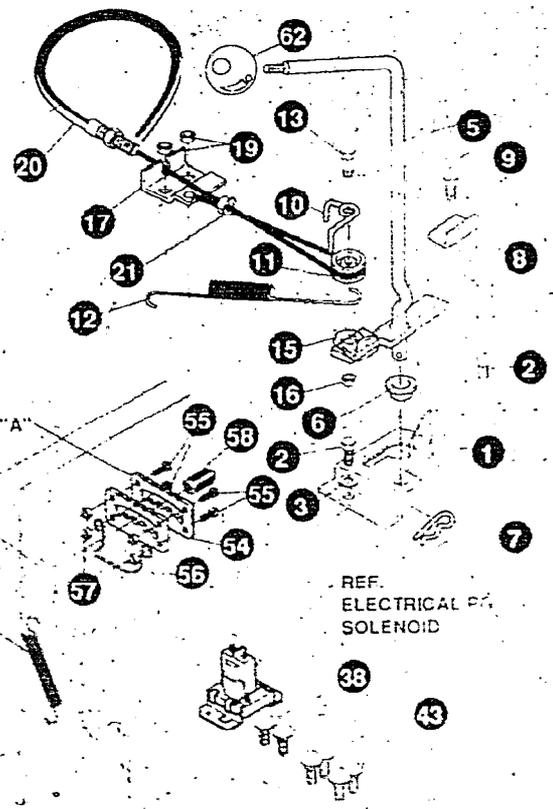

SEE
DETAIL "A"

REF.
ELECTRICAL PG.
SOLENOID

REF.
KEY#18

REF.
CHASSIS, & HOOD PG.
MAIN FRAME

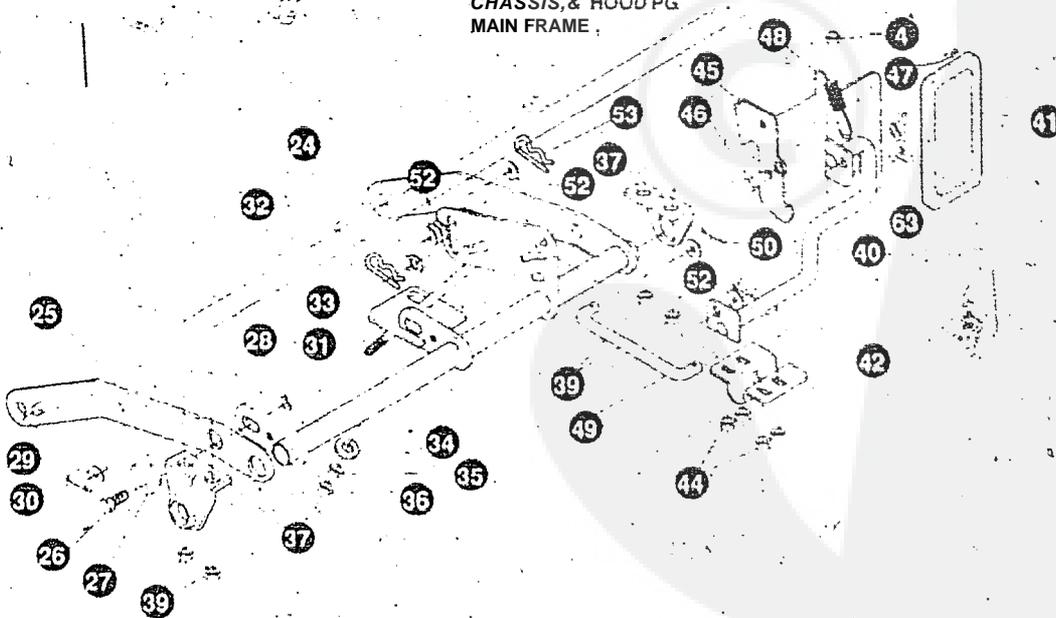

NOTE: ALWAYS USE ORIGINAL EQUIPMENT PARTS.
Use of service/replacement parts other than original
equipment parts may, void your warranty

ALL UNNUMBERED
ITEMS ARE INTERCHANGEABLE
WITH OPPOSITE SIDE

3258110

KEY#	PART#	DESCRIPTION	QTY
1	320075-853	BRACKET, CLUTCH ENGAGE LEVER	1
2	180079	SCREW, 5/16-18 X 1.00 HHC	2
3	1 2 0 3 9 3	WASHER, FIAT .344 X .69 X .065	2
4	1498	NUT, 5/16-18 REGHEXCTRLK	2
5	304791	ASSEMBLY, CLUTCH LEVER	1
6	50148	BEARING, FLANGE SO3 ID X .63 OD X .50	1
7	8260	PIN, HAIR .091 DIA X 1.66 LONG	1
8	318341	BRACKET, SWITCH ENGAGE	1
9	35498	SCREW, 5/16-18 X .75 WAHTAP	1
10	324032	SPRING, CABLE KEEPER, 390 ID	1
11	48305	PULLEY, POWDER METAL	1
12	3 1 6 6 4 8	SPRING, .071 X .62 X 12.88	1
13	3 2 4 0 4 5	BOLT, .375 X .565 HSSH	1
14	1288	BRACKET, CABLE RETAINER	1
15	1502	NUT, 1/4-20 REGHEXCTRLK	1
16	300698-853	BRACKET, FRAME CABLE	1
17	180020	SCREW, 1/4-20 X .75 HHC	2
18	1502	NUT, 1/4-20 REGHEXCTRLK	2
19	324055	ASSEMBLY, CABLE, BLADE ENGAGE	1
20	120613	NUT, 1/4-28 HJAM	1
21	35498	SCREW, 5/16-18 X .75 WAHTAP	1
22	57444	TIE, CABLE BLACK, NYLON 5 62 LONG	1
23	322835853	LIFT ASSEMBLY, LH	1
24	300169-853	LIFT ASSEMBLY, RH	1
25	180079	SCREW, 5/16-18 X 1.00 HHC	1
26	58247	NUT, ADJUST	1
27	1498	NUT, 5/16-18 REGHEXCTRLK	1
28	4 17098	WASHER, FIAT .531 X 1.06 X .063	2
29	8260	PIN, HAIR .091 DIA X 1.66 LONG	2
30	322821	ROD, ADJUSTING, "J" P-LIFT ZINC	1
31	120394	WASHER, FLAT 406 X 81 X 065	1
32	36368	PIN, HAIR .072 DIA X 1.13 LONG	1
33	996416	WASHER, FLAT .391 X 100 X 125	1
34	120377	NUT, 3/8-16 REGHX	1
35	322467	NUT, 3/8-16 HXHDNYLON, INSERT	1
36	58248-853	BRACKET, REAR HANG, SUSP	2
37	57072	BOLT, 5/16-18 X .63 CARRLN	4
38	1498	NUT, 5/16-18 REGHEXCTRLK	4
39	314962-853	PEDAL ASSEMBLY DECK HEIGHT	1
40	328596	PAD, LIFT PEDAL	1
41	323751	BRACKET, LIFT ARM, BLACK	1
42	57072	BOLT, 5/16-18 X .63 CARRLN	4
43	44108	NUT, 5/16-18 HWDFLCTRLK	4
44	315342	LATCH, PEDAL LIFT	1
45	314829	BOLT, .56X 13 HSSH, 3/8-16	1
46	1499	NUT, 3/8-16 REGHXCTRLK	1
47	314489	SPRING, LIFT LATCH	1
48	314792	ROD, PIVOT	1
49	121222	PIN, COTTER .090 DIA X .75 LONG	2
50	321385	ROD, MEMORY	2
51	120394	WASHER, FIAT .406 X .81 X .065	4
52	36368	PIN, HAIR .072 DIA X 1.13 LONG	1
53	315341	BRACKET, MEMORY	2
54	44811	SCREW, 1/4-20 X .75 WAHTAP	4
55	324038	GUIDE, MEMORY ROD - NEW ADJT	1
56	1502	NUT, 1/4-20 REGHEXCTRLK	4
57	314969	CAP, MEMORY ROD, 38 ID X 75	1
58	314837	SPRING, MEMORY	1
59	180077	SCREW, 5/16-18 X .75 HHC	1
60	1498	NUT, 5/16-18 REGHEXCTRLK	1
61	55514	KNOB, ROUND 1.50 DIA, BLACK	1
62	309235	FASTENER, R A T C H E T BLACK	1

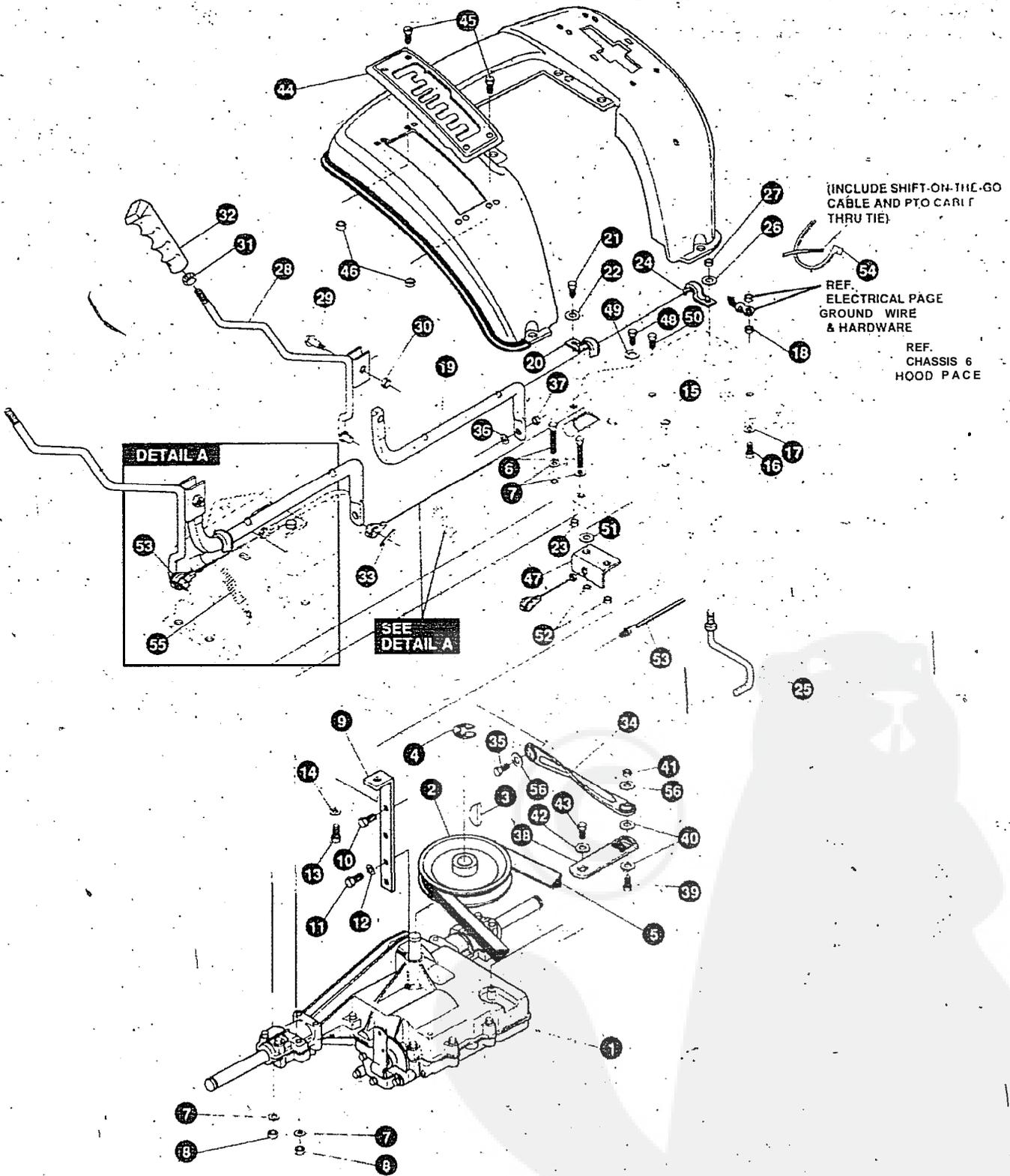

NOTE: ALWAYS USE ORIGINAL EQUIPMENT PARTS.
 Use of service/replacement parts other than original equipment parts may void your warranty.

ALL UNNUMBERED ITEMS ARE INTERCHANGEABLE WITH OPPOSITE SIDE

334423 A

KEY#	PART#	DESCRIPTION	QTY
1		TRANSAXLE, FOOTE, 4360-6-SPHD	1
2	302745	PULLEY, 6.6 OD, V4L, T/A	1
3	5 0 7 9 5	KEY, HI-PRO, 606, .75 DIA X .187 WD	1
4	22053	RING, RETEX, .58 X .035 TRU, 5100-62	1
5	314120	BELT, V 4L, 87.25, 4WS, LF	1
6	180113	SCREW, 5/16-18 X 3.00 HHC	4
7	i 20393	WASHER, FLAT, .344 X .69 X .065	8
8	1498	NUT, 5/16-18 REGHEXCTRLK	4
9	323739	BRACKET, STABILIZER	1
10	50947	SCREW, 3/8-16 X 1.25 WAHHTAP	1
1 1	35498	SCREW, 5/16-18 X .75 WAMHTAP	1
1 2	120638	WASHER, HVSPTLK 328 x .60 X .09	1
13	180079	SCREW, 5/16-18 X 1.00 HHC	1
14	120393	WASHER, FLAT, .344 x .69 x .a65	1
1 5	1498	NUT, 5/16-18 REGHEXCTRLK	1
16	180077	SCREW, 5/16-18 X .75 HHC	1
17	138538	WASHER, REGINTLK 320 X 61 x a3	1
1 8	1498	NUT, 5/16-18 REGHEXCTRLK	1
19	319209	LEVER, SHIFT-LOWER, SHIFT N GO, LF	1
20	310347-853	CLIP- SHIFT LEVER, .625 ROD	1
2 1	180077	SCREW, 5/16-18 X .75 HHC	1
22	9 9 6 4 1 6	WASHER, FLAT, .391 X 1.00 X .125	1
2 3	1 4 9 8	NUT, 5/16-18 REGHEXCTRLK	1
24	310347-853	CLIP- SHIFT LEVER, .625 ROD	1
25	57259	GUIDE, BELT 5/16-18 THD	1
26	996416	WASHER, FLAT, .391 x 1.00 x .125	1
27	1498	NUT, 5/16-18 REGHEXCTRLK	1
28	320383	UPPER SHIFT LEVER ASSEMBLY	1
29	321092	BOLT, .380 X 500 HSSH, 1/4-20	1
30	50352	NUT, 1/4-20 WDFLLK TOPLOCK	1
- 3 1	120377	NUT, 3/8-16 REGHX	1
32	3 0 6 6 8 9	HANDLE, 3/8-16 MOLDED, BLACK	1
33	137185	PIN; COTTER, .125 DIA X 100 LONG	1
34	316557	LINK, TIE ROD, SHIFT, 7.477C/L	1
35	180124	SCREW, 3/8-16 X 1.25 HHC	1
3 6	120382	WASHER, REGSPTLK, 393 x .68 x .10	1
37	1499	NUT, 3/8-16 REGHXCTRLK	1
38	309637	BRACKET, SHIFT, 5SP, SF	1
39	180124	SCREW, 3/8-16 X 1.25 HHC	1
40	120394	WASHER, FLAT, .406 X .81 X .065	2
41	1499	NUT, 3/8-16 REGHXCTRLK	1
42	57157	WASHER, 750 X 250 SP-TRANSAXLE	1
43	5 6 2 5 5	SCREW, 1/4-28 X .75 NYLHHC	1
44	319806-853	QUADRANT, SHIFT, FOOTE, F4360-6HD	1
45	305850	SCREW, 1/4-20 X .50 PHPNTAP	1
4 6	1502	NUT, 1/4-20 REGHEXCTRLK	1
47	3 2 , 1 5 1 7	BRACKET, FRAME, SHIFT	1
48	180022	SCREW, 1/4-20 X 1.00 HHC	1
4 9	120392	WASHER, FLAT 281 X .63X .065	1
50	57038	BOLT, 1/4-20 X .63 CARRLN	1
-51	316080	SPACER, .328 X .50 X .38	1
5 2	1502	NUT, 1/4-M REGHEXCTRLK	2
5 3	319803	CABLE, SHIFT N GO	1
54	5 7 4 4 4	TIE, CABLE BLACK NYLON, 5.62 LONG	1
55	314837	SPRING, MEMORY	1
56	120394	WASHER, FLAT 406 x .81 x .065	2

SEE YOUR NEAREST TRANSAXLE DEALER FOR PARTS 8 SERVICE

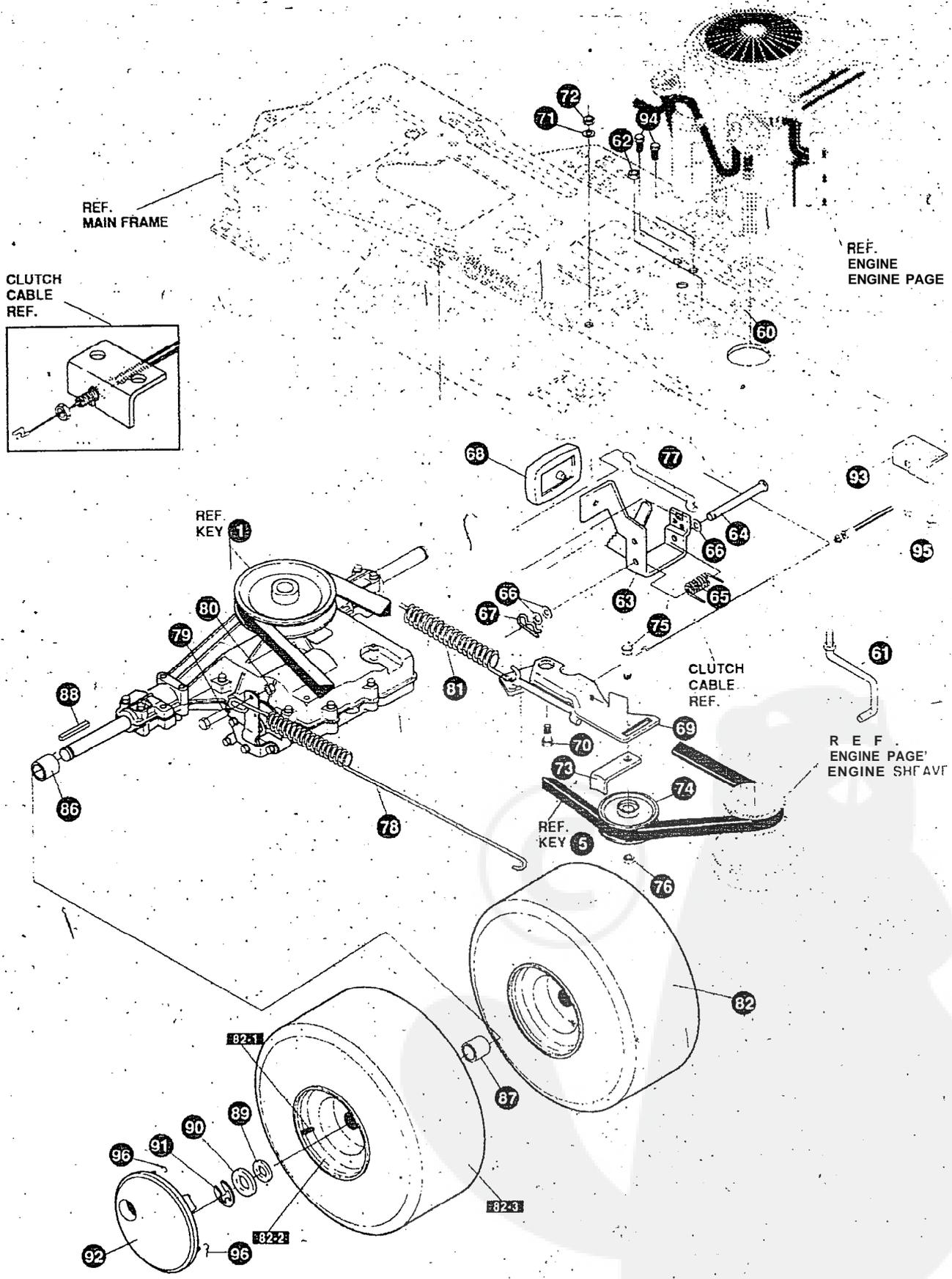

NOTE: ALWAYS USE ORIGINAL EQUIPMENT PARTS.
 Use of service/replacement parts other than original
 equipment parts may void your warranty.

ALL UNNUMBERED
 ITEMS ARE INTERCHANGEABLE
 WITH OPPOSITE SIDE

334423 A

KEY#	PART#	DESCRIPTION	QTY
60	321514	SPRING, DRAG LINK BIAS.	1
61	304016	GUIDE. BELT, RH	1
62	1498	NUT, 5/16-18 REGHEXCTRLK	1
63	325942	PEDAL ASSEMBLY, BRAKE/CLUTCH, LF	1
64	3 1 9 6 7 5	PIN, CLEVIS .500 D X 4.53 LONG	1
65	5 7 8 4 7	SPRING, BRAKE PEDAL	1
66	2968	WASHER, FLAT .504 X .75 X .059	3
67	56180	PIN, HAIR .091 DIA X 1.62 LONG	1
68	48160	PAD, CLUTCH BRAKE, W/PRINTING	1
69	320381	ARM, IDLER TRACTION, SOG, L F	1
70	3 2 9 9 8 9	BOLT, .625 X .135 HHSH, 5/16-18	1
71	4 5 6 0 2	WASHER, FIAT .333 X .a7 X .119	1
72	1498	NUT, 5/16-18 REGHEXCTRLK	1
73	3 9 6 5 9	RETAINER, BELT	1
74	35374	PULLEY, IDLER, V4L, 3.06 X .62	1
75	4 5 8 9 2	BOLT, 3/8-16 X 1.50 CARRSN	1
76	1499	NUT, 3/8-16 REGHXCTRLK	1
77	57204	ROD, CLUTCH: 3.92	1
78	325937	SPRING, BRAKE, 28.80, 930, 4360	1
79	326131	BOLT, .495 X .31 HHSH, 5/16-18	1
80	1498	NUT, 5/16-18 REGHEXCTRLK	1
81	322609	SPRING, CLUTCH	1
82	*	TIRE & RIM, 20 X 8.00-8	2
82-1	2 4 1 6 7	VALVE STEM	
82-2	57165	RIM, WHEEL	
82-3	TIRE	REFER TO TIRE TREAD PAGE	
86	57479	SPACER, SLEEVE .75 X 1.25 X 1.32	2
87	301565	SPACER, SLEEVE .750 X 1.25 X .50	2
88	5 2 9 2 8	KEY, SQUARE 187 SQUARE X 2 25 LONG	2
89	642	WASHER, FLAT .755 X 1.31 X .075	4
90	42815	WASHER, FLAT .755 X 1.53 X .07	2
91	36625	RING, RETEX .57 X .05 TRU 5133-75	2
92	30444 1	HUB CAP, 8" EURO, GREY	2
93	321517	BRACKET, FRAME SHIFT	1
94	180020	SCREW, 1/4-20 X .75 HHC	2
95	1502	NUT, 1/4-20 REGHEXCTRLK	2
96	306669	CLIP, HUBCAP TINN#C25467-017-4	10

* ORDER INDIVIDUAL PARTS - ASSEMBLY NOT AVAILABLE

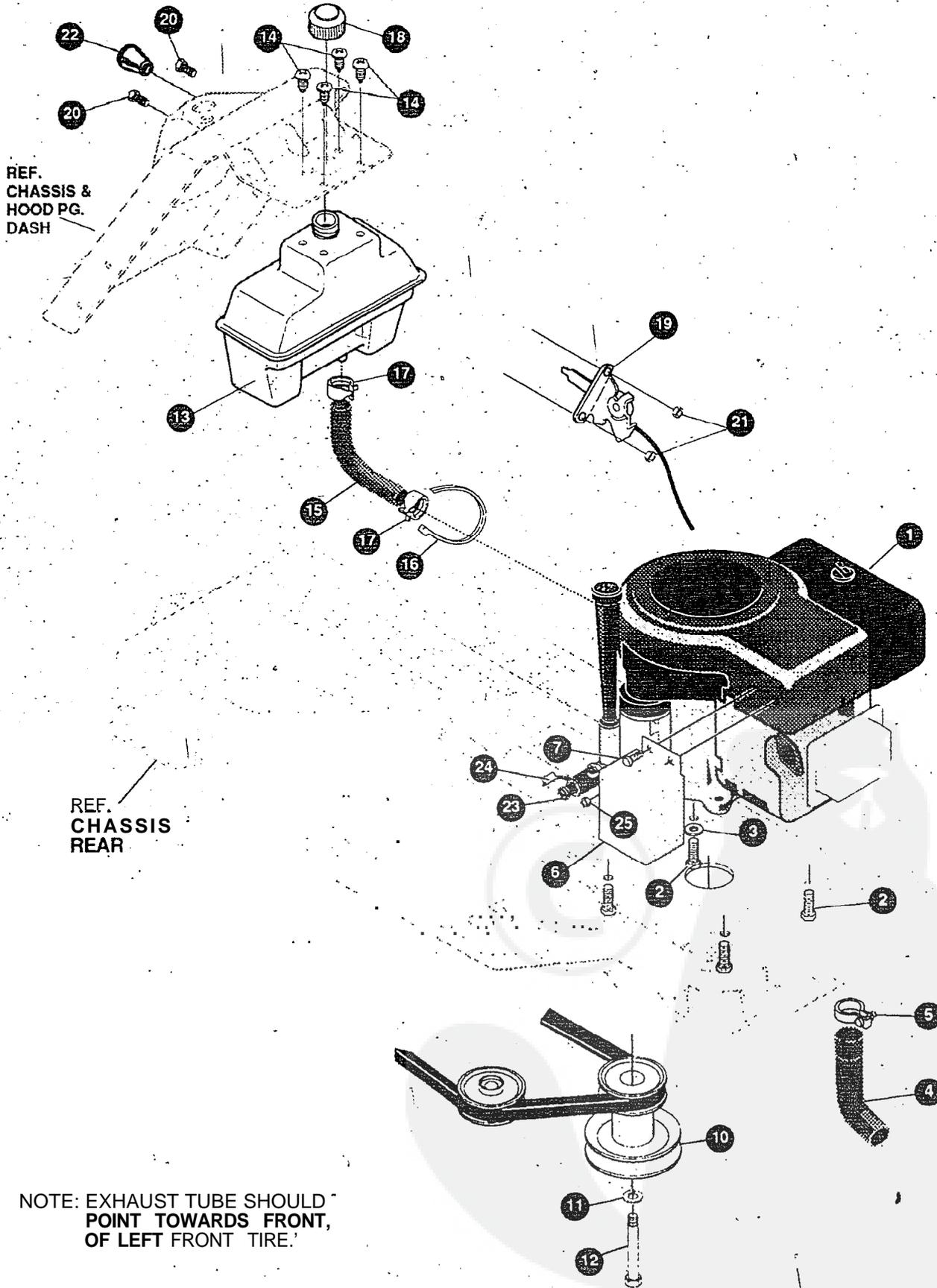

REF.
CHASSIS
REAR

NOTE: EXHAUST TUBE SHOULD POINT TOWARDS FRONT, OF LEFT FRONT TIRE.

NOTE: ALWAYS USE ORIGINAL EQUIPMENT PARTS. Use of service/replacement parts other than original equipment parts may void your warranty.

ALL UNNUMBERED ITEMS ARE INTERCHANGEABLE WITH OPPOSITE SIDE

332364-C

K E Y #	PART#	DESCRIPTION	QTY
1		ENGINE, 14.0HP, B&S, IC, OHV DUAL CIRCUIT	1
2	50947	S C3/8-16RX125 WAHHTWPBLK	4
3	138489	WASHER, EXLK 384 X 69 X 04	1
4	327868	EXHAUST TUBE, 14HP, OHV, B&S, LF, H15	1
5	328024	CLAMP EXHAUST 137 DIA	1
6	327785-853	HEAT SHIELD, 14HP, OHV, B&S	1
7	9953.46	SCREW, 5 0 W A H H T A P	3
10	328028	PULLEY, ENGINE 3 OD X 4 0 LONG X 5 0 D	1
11	120383	WASHER, REGSPTLK 459 X 78X 12	1
12	433146	SCREW, 7/16-20 X 4 25 HHC, BLACK	1
13	3 14989	TANK, FUEL 1 GALLON, CLEAR	1
14	49050	SCREW, 1/4-10 X 7 5 P H P N T A P	4
15	"50118	TUBING, .25 X 50 X BULK GAS LINE	13 5"
16	57444	TIE, CABLE BLACK NYLON, 5.62 LONG	1
18	467045	CLAMP, HOSE SC1-1/2-7 THD, BLACK	1
19	321273	CONTROL, THROTTLE, 12-12 5HP, LF	1
20	320553	SCREW, 10-24 X 63 PHPNMA CRSS	2
21	308459	NUT, #10-24 HXHDNYLK	2
22			1
23	50607 3 2 5 5 4 7	OIL KNOB, DRAIN ROUND VALVE THROTTLE, ASSEMBLY, BLACK	1
24	327422	CAP. OIL DRAIN VALVE ASSEMBLY, YELLOW	1
2 5	1 2 4 8 1 8	NUT, 1/4-20 REGHXJAM	1

SEE ENGINE MANUAL

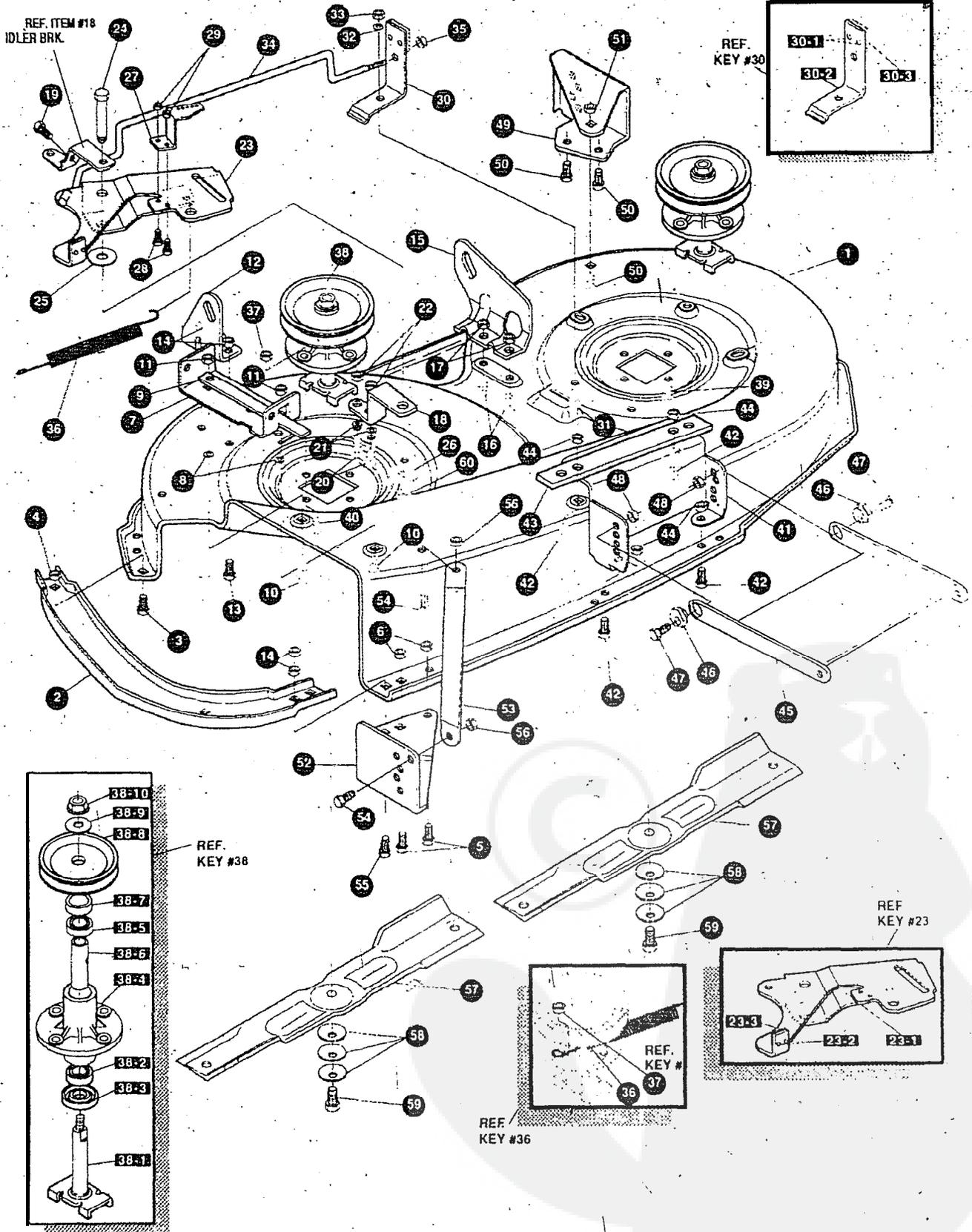

NOTE: ALWAYS USE ORIGINAL EQUIPMENT PARTS. Use of service/replacement parts other than original equipment parts may void your warranty.

ALL UNNUMBERED ITEMS ARE INTERCHANGEABLE WITH OPPOSITE SIDE

331147 D

KEY#	PART#	DESCRIPTION	QTY
	325103	40" DECK KIT	1
2	326480	TOE GUARD - MULCHER	1
3	180077	SCREW, 5/16-18 X .75 HHC	1
4	1498	NUT, 5/16-18 REGHEXCTRLK	1
5	f80077	SCREW, 5/16-18 X .75 HHC	1
6	1498	NUT, 5/16-18 REGHEXCTRLK	2
7	317017	BRACKET CHUTE MOUNT. BLACK	1
8	120393	WASHER, FWT .344 X .69 X .065	2
9	322320	LEVER ASSEMBLY (SHORT)	1
9-1	58319	PIN	1
9-2	322319	LEVER, CHUTE LATCH (SHORT)	1
10	180077	SCREW, 5/16-18 X .75 HHC	2
11	1498	NUT, 5/16-18 REGHEXCTRLK	2
12	313929	LIFT BRACKET, REAR, RH. BLACK	1
13	180077	SCREW, 5/16-18 X .75 HHC	2
14	1498	NUT, 5/16-18 REGHEXCTRLK	2
15	310667	BRACKET, LH. LIFT REAR	1
16	180077	SCREW, 5/16-18 X .75 HHC	2
17	1498	NUT, 5/16-18 REGHEXCTRLK	2
18	326893	BRACE, IDLER SUPPORT. 40", 43"	1
19	308231	SCREW, 1/4-20 X 1 25 HHWATAP	1
20	180077	SCREW, 5/16-18 X .75 HHC	2
21	120393	WASHER, FLAT 344 X 69 X 065	2
22	44108	NUT, 5/16-18 HWDFLCTRLK	2
23	320576	IDLER ARM ASSEMBLY	1
29-1	322116	ARM, IDLER 40/43" DECK	1
-23-2	41601	RIVET, OVSET 187 DIA X 50 LONG	2
23-3	306973	BRAKE PAD HARD-NF343 (X-31)	1
24	304420	BOLT, 500 X 2 15 HSSH	1
25	996307	WASHER, FLAT 391 X 1 00 X 209	1
26	996416	WASHER, FLAT 391 X 1 00 X 1.25	2
27	326249	BRACKET, EXTENSION IDLER	1
28	180077	SCREW, 5/16-18 X .75 HHC	2
29	1498	NUT, 5/16-18 REGHEXCTRLK	2
30	321628	BLADE BRAKE ASSEMBLY	1
30-1	135624	RIVET, TRSET 185 DIA X 41 LONG	2
30-2	304119	BRAKE ARM	1
30-3	306973	BRAKE PAD HARD-NF343 (X 3)	1
31	180077	SCREW, 5/16-18 X .75 HHC	1
3 2	120393	WASHER, FLAT 344 X 69 X 065	1
33	1498	NUT, 5/16-18 REGHEXCTRLK	1
3 4	315396	ROD, BRAKE 40" DECK	1
35	1502	NUT, 1/4-20 REGHEXCTRLK	1
36	35410	SPRING, 071 X 62X437	1
37	1498	NUT, 5/16-18 REGHEXCTRLK	1
38	56424	QUILL ASSEMBLY, 36/39/40/43	2
38-1	56425	SHAFT/SADDLE 36"	1
38-2	49562	BEARING, BALL 6203-2AA-C3 ARMORED	1
38.3	50616	DUST SHIELD	1
3 8 - 4	55547	QUILL CASTING (104A)	1
38-5	49562	BEARING, BALL 6203-2AA-C3 ARMORED	1
38-6	50818	SPACER, SLEEVE 669 X 88 X 3797	1
38-7	51449	SPACER: SLEEVE 672 X 93 X 438	1
38-8	3 13898	PULLEY ASSEMBLY	1
38-9	56365	WASHER, SPECIAL QUILL	1
38-10	1282	NUT, 7/16-20 WDFLLK	1
39	35498	SCREW, 5/16-18 X .75 WAHTAP	1
40	300345	SCREW, 5/16-18 X 1 38 WAHTAP	1
41	318445	BRACKET, 40. LF, FRONT DECK	1
42	180077	SCREW, 5/16-18 X .75 HHC	4
43	328155	PLATE-MOUNTING	1
44	1498	NUT, 5/16-18 REGHEXCTRLK	4
45	5 8 3 0 5	BRACKET, LINK, DECK FRONT	1
46	58247	NUT, ADJUST	2
47	180079	SCREW, 5/16-18 X 1 00 HHC	2
48	1498	NUT, 5/16-18 REGHEXCTRLK	2
49	317041	BRACKET, GAUGE WHEEL LH	1
50	1 8 0 0 7 7	SCREW, 5/16-18 X .75 HHC	3
51	1498	NUT, 5/16-18 REGHEXCTRLK	3
52	322464	BRACKET, GAUGE WHEEL RH. FRONT	1
5 3	314282	BRACKET, STABILIZER	1
54	180077	SCREW, 5/16-18 X .75 HHC	1
55	12605	SCREW, 5/16-18 X 1 50 HHCFT	1
56	1498	NUT, 5/16-18 REGHEXCTRLK	1
57	313316	BLADE 40" STD LIFT, 20 32	2
58	2483	WASHER, 39 ID X 1 25 D X 07 BELL 3 IL	6
59	39573	SCREW, 3/8-24 X 1 00 NYLHHC	2
60	45171	NUT, 3/8-16 HWDFL WHIZ-LOCK	1

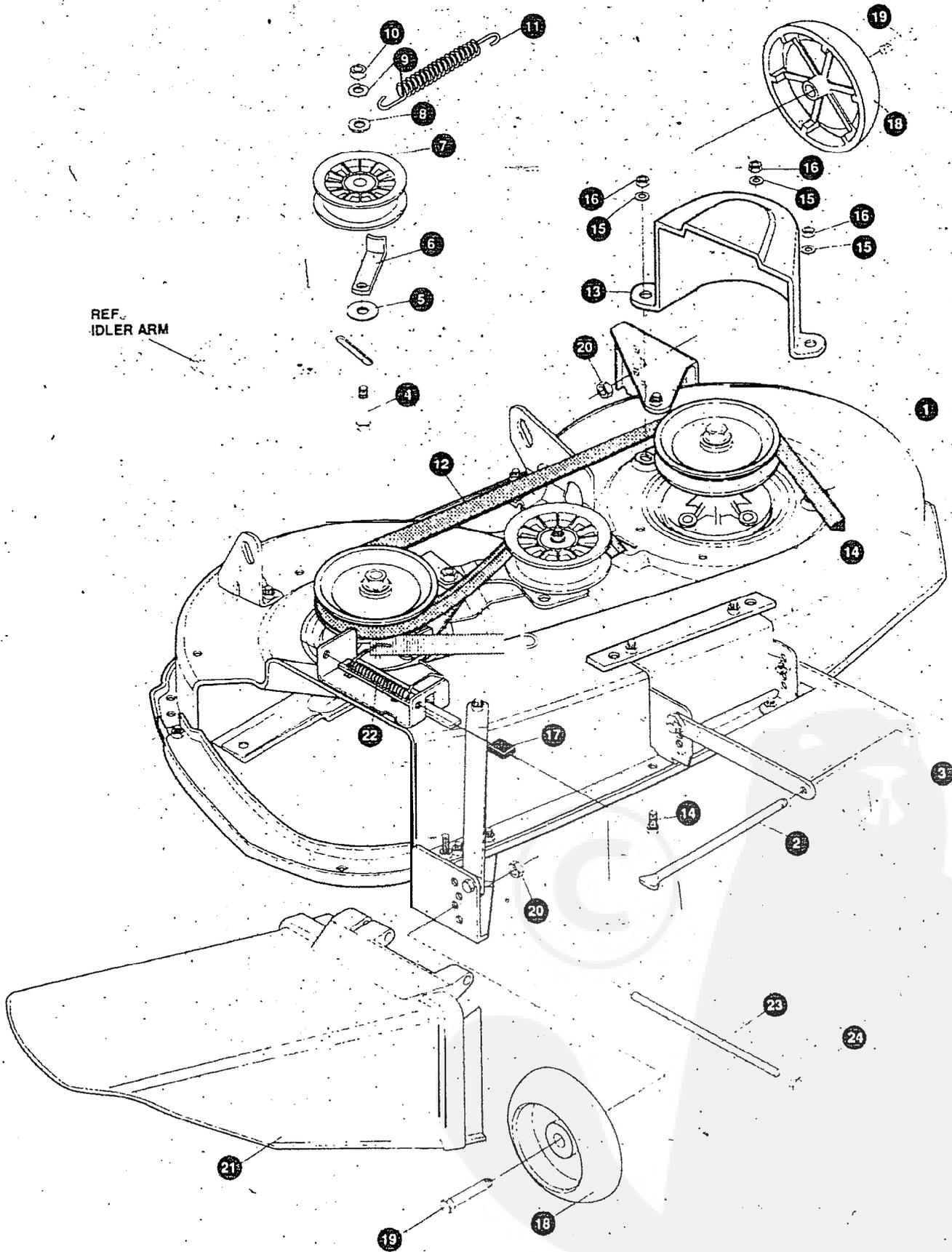

REF.
IDLER ARM

NOTE: ALWAYS USE ORIGINAL EQUIPMENT PARTS.
Use of service/replacement parts other than original equipment parts may void your warranty.

ALL UNNUMBERED
ITEMS ARE INTERCHANGEABLE
WITH OPPOSITE SIDE

3'31145 E

KEY#	PART#	DESCRIPTION	QTY
1	3 2 9 0 3 5	ASSEMBLY 40" DECK FOR AIR ASSIST	1
2	58306	ROD, DE & H - I T C H	1
3	8 2 6 0	PIN, HAIR 091 DIA X 1 66 LONG	1
4	57325	BOLT, 3/8-16 X 2 00 CARBEN	1
5	25210	WASHER, FLAT 386 X 1 25 X 09	1
6	1346	RETAINER, BELT	1
7	310326	PULLEY, IDLER, BFF 4 00 WIDE FL	1
8	996307	WASHER, FLAT 391 X 1 00 X 209	1
9	120382	WASHER, REGSPTLK 393 X 68 X 10	1
10	120377	NUT, 3/8-16 REGHX	1
1 1	300473	SPRING, TENSION 7 52 LONG-17 LB/IN	1
12	3 1 9 0 0 5	BELT, V 5L, 81 00, DECK, 40 LF	1
13	328257	GUARD, BELT, LH. PLASTIC	1
14	180077	SCREW, 5/16-18 X 75 HHC	3
15	120393	WASHER, FLAT 344 X 69 X .065	3
16	1498	NUT, 5/16-18 REGHEXCTRLK	3
17	42340	GRIP-LEVER, GRASS COLLECTOR	1
18	3 0 2 6 1 1	GAUGE WHEEL,, EURO, 6 00 OD X 138-WD	2
19	23763	BOLT, 500 X 1 390 HSSH 3/8-16	2
20	1499	NUT, 3/8-16 REGHXCTRLK	2
21	304422	CHUTE DEFLECTOR, 40' 42" 8 43"	1
22	314975	SPRING, TORSION, CHUTE DEFLECTOR	1
23	3 0 4 4 2 4	ROD, PIVOT DECK, 3 12 D X 7 25	1
24	3535	NUT, PUSH ON CAP 312 OD	1

KEY#	PART#	DESCRIPTION	QTY
1	328253	HARNES, 14HP, OHV, WRAPPED, DYN L F	1
2	41482	PRESS CLIP, 1.380 LONG, 255 ID	1
3		ASSEMBLY, LIGHT, WIRE-1/4 TURN	1
4	303064 52572	BULB, HEADLAMP	2
5	57444	TIE, CABLE BLACK NYLON, 5.62 LONG	3
6	41482	PRESS CLIP, 1.380 LONG, 255 ID	2
7	327355	SWITCH-IGNITION AFTER FIRE) 3 POSITION	1
8	327352	NUT, 5/8-8 ACME DELTA FOR BOOT	1
9	327350	KEY, IGNITION	2
10	300133	A M M E T E R	1
11	300334	LIGHT SWITCH, ON/OFF, PANEL MOUNT	1
12	320082	SWTCH. DOUBLE POLE NO/NC, GRAY	1
13	57444	TIE, CABLE BLACK NYLON, 5.62 LONG	1
14	57476	SWITCH, SCREW MOUNT. DP. NC, NO. BLACK	1
15	57220	SCREW, #12 X .50 PHPNHTAP. BLACK	2
16	53716	SOLENOID	1
17	18.7745	S C R E W , 1/4-20 X .75 HXSEMMA	2
18	1502	NUT, 1/4-20 REGHEXCTRLK	2
19	271172	N U T . 1/4-20 REGHEXKEPS	1
20	138485	WASHER, EXLK 320 X 61 X .03	2
21	120368	NUT, 5/16-24 REGHEX	2
22	57444	TIE, CABLE BLACK NYLON, 5.62 LONG	1
23	55511	WIRE, GROUND, 12.5"	1
24	271184	NUT, 5/16-18 HEXKEPS	1
25	57547	S W I T C H . S E A T	1
26	160505	SCREW, 1/4-20 X .38 PHPNHMA	2
27	92693	BATTERY, 12V	1
28	57551	ROD, BATTERY	1
29	57552	ROD, BATTERY, TOP	1
30	325232	NUT, WING 1/4-20 NYLON	1
31	180020	SCREW 1/4-20 X .75 HHC	2
32	271172	NUT, 1/4-20 REGHEXKEPS	2
35	91895	TRAY - BATTERY	1

SCHEMATIC DRAWING

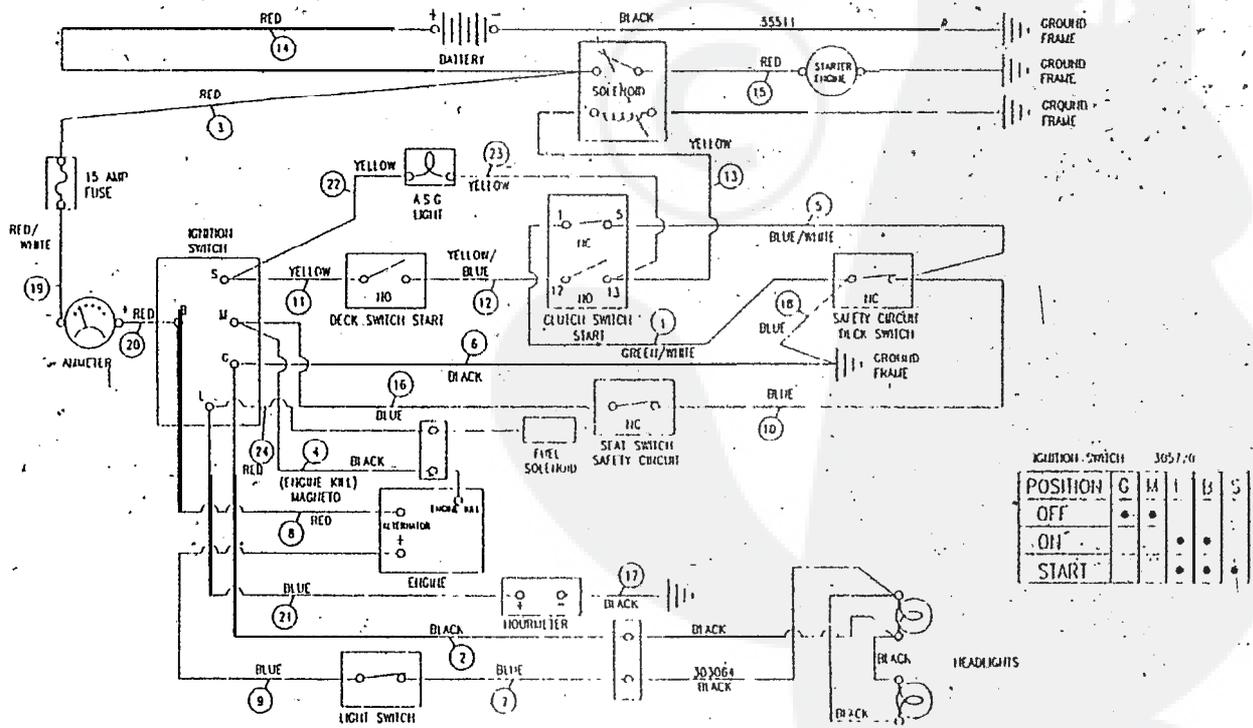

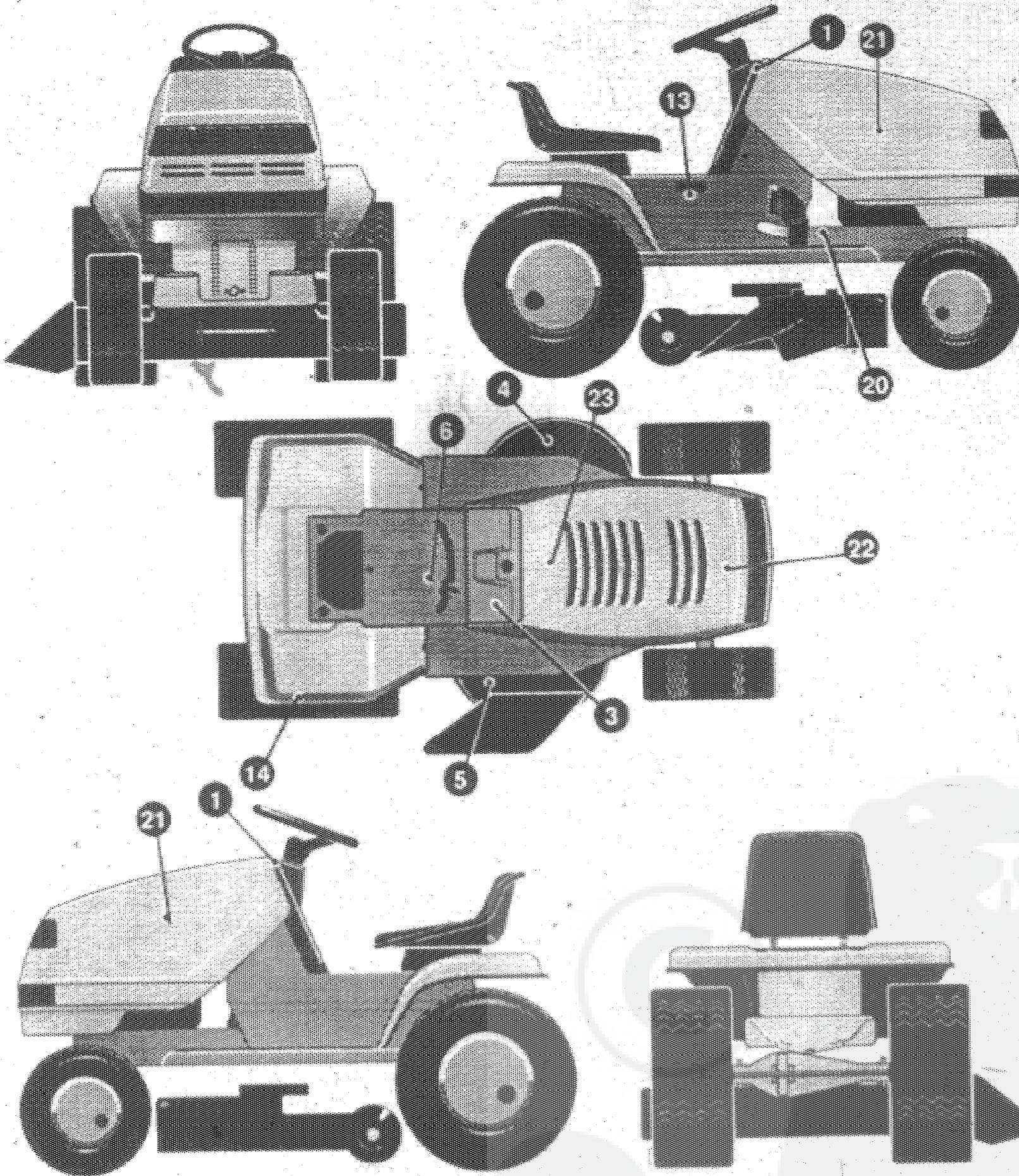

KEY#	PART#	DESCRIPTION	QTY
1	313208	DECAL, DASH, WEAR STRIP, RED	2
3	321765	DECAL, LF, DASH, PTO/LIGHT SWITCH, EXP	1
4	402700	DECAL, CAUTION, DECK, LH	1
5	402701	DECAL, CAUTION, DECK, RH	1
6	402689	DECAL, CONSOLE, SYMBOLIC, CAUTION	1
13	314945	DECAL, 5-POSITION, CUT HEIGHT	1
14	322169	DECAL, FENDER, 6 SPEED, SOG	1
20	402702	DECAL, BRAKE/CLUTCH	1
21	305603	PAD, 18 X 6 FOAM HOOD	2
22	307277	PAD, 12 X 4 FOAM HOOD	1
23	305602	FOAM HOOD 4 X 15	1

335455 A

TREAD PATTERNS

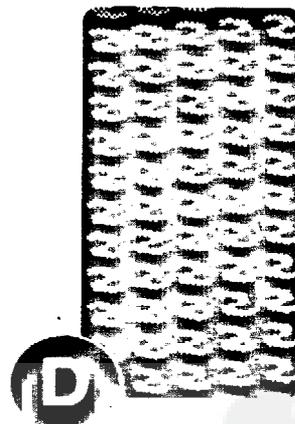
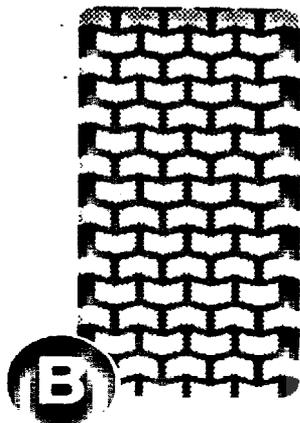
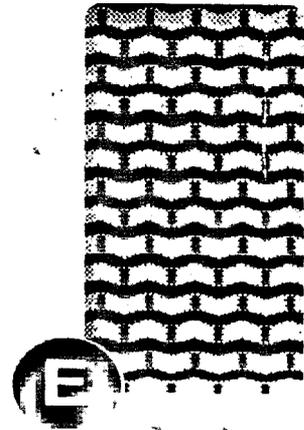
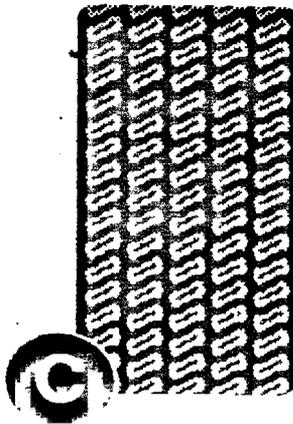
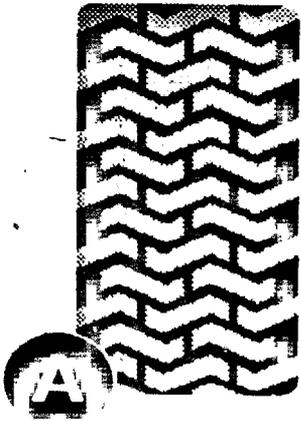

TIRE SIZE	"A"	"B"	"C"	"D"	"E"
11x4. 00- 5	42295	319679			
13X5. 00- 6	41060	319680			
15X6. 00- 6	39830	316702	301140	313952	
16X4. 80- 8		305035			
16X6. 50- 8	41081	319682		314539	
18X6. 50- 8		42091			
18X8. 50- 8	319683	317400			
18X9. 50- 8	41106	316701		313950	
20X8. 00- 8	319685	319684	57164	314584	331606
20X10. 00- 8	58276	319686		313654	
20x10. 00- 10	55893	319687			
23x9. 50- 12	53655	319690	3 1 9 6 8 9	314370	