

REPAIR

PARTS MANUAL

Model F3560-310



12.5HP/40" Deck

HOW TO ORDER REPAIR PARTS

Only use a factory repair part. Repair parts, except for the engine or the transmission, are available from the store where the unit was purchased, a service shop recommended by the store, or an authorized service shop found in the yellow pages of the telephone directory.

If you cannot get a repair part or service as described above, call or write to the Central Parts Distributor shown on the back page of this manual or write: **Customer Service Department, Outdoor Power Equipment, PO Box 8000, Jackson, TN 38308, 1-800-247-7464**. Collect telephone calls will not be accepted. When you order, include the following information: 1- Complete Model Number (see nameplate), 2- Date of Manufacture, 3- Complete Part Number, 4- Description, and 5- Quantity.

Repair parts for the engine or the transmission are available from the manufacturer's authorized service center found in the yellow pages of the telephone directory. See the individual engine or transmission warranties.

- Read and keep this parts list book for future reference.
- This parts list book contains drawings and part numbers necessary to obtain repair parts.
- Record the following information about your unit. This information is necessary when ordering parts or in case of loss or theft.

WHERE PURCHASED: _____

DATE PURCHASED: Month _____ Day _____ Year _____

MODEL NO.: _____ DATE OF MANUFACTURE: _____

F3560-310

REPAIR PARTS

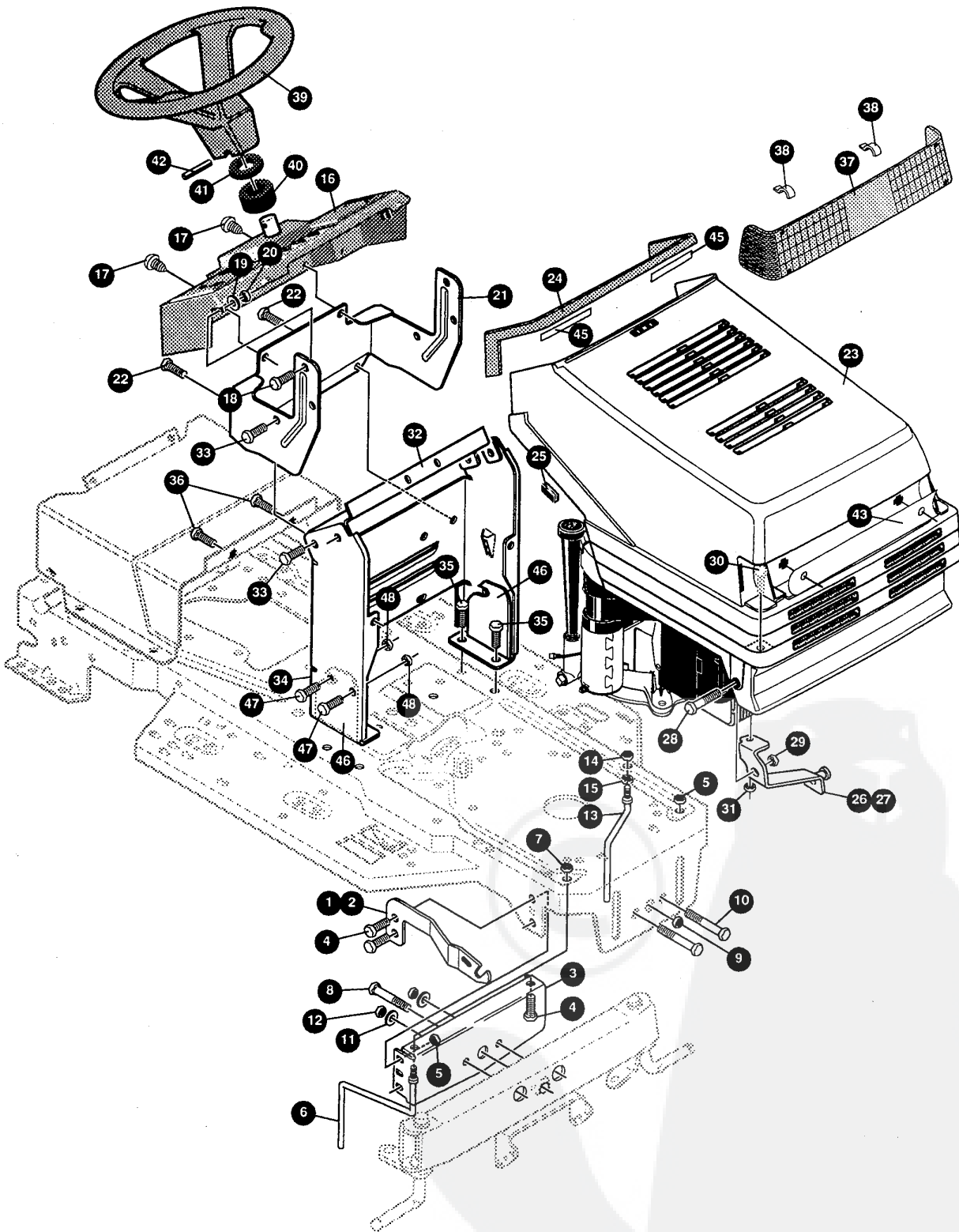

NOTE: ALWAYS USE ORIGINAL EQUIPMENT PARTS.
Use of service/replacement parts other than original equipment parts may void your warranty.

**ALL UNNUMBERED
ITEMS ARE INTERCHANGEABLE
WITH OPPOSITE SIDE**

329883 E

F3560-310 FRONT CHASSIS & HOOD ASSEMBLY

KEY#	PART#	DESCRIPTION	QTY
1	330815-853	BRACKET, HOOD, RH	1
2	330816-853	BRACKET, HOOD, LH	1
3	313541-853	BRACKET, FRONT AXLE	1
4	56030	SCREW, 5/16-18 X .75 WDFLLK	5
5	55273	NUT, 5/16-18 WDFLLKLRG WHIZ	5
6	300440	GUIDE, BELT, RIDER	1
7	1498	NUT, 5/16-18 REGHEXCTRLK	1
8	308207	BOLT, .625 X 2.18 HSSH, 1/2-13	1
9	309008	NUT, 1/2-13 HEXJAM CTRLK	1
10	180138	SCREW, 3/8-16 X 3.00 HHC	2
11	2483	WASHER, .39 ID X 1.25 D X .07 BELLVIL	2
12	1499	NUT, 3/8-16 REGHXCTRLK	2
13	300635	GUIDE, BELT, SHORT, 15" WHEEL	1
14	124824	NUT, 5/16-18 HEXJAM	1
15	271190	NUT, 3/8-16 HEXKEPS	1
16	331135	DASH, SHORT	1
17	318304	SCREW, 1/4-14 X.75 PHPNHDTAP	2
18	180020	SCREW, 1/4-20 X .75 HHC	2
19	120392	WASHER, FLAT .281 X .63 X .065	2
20	1502	NUT, 1/4-20 REGHEXCTRLK	2
21	330807-830	COVER, DASH	1
22	318304	SCREW, 1/4-14 X.75 PHPNHDTAP	2
23	304377	HOOD	1
24	12675	TRIM PIECE, PLASTIC	1
25	306822	CLIP, U-TYPE TINN C27637-014-4	2
26	331068-853	BRACKET, HOOD, RH	1
27	331069-853	BRACKET, HOOD, LH	1
28	333594	BOLT, .500 X .177 HSSH, 5/16-18	2
29	1498	NUT, 5/16-18 REGHEXCTRLK	2
30	180079	SCREW, 5/16-18 X 1.00 HHC	2
31	1498	NUT, 5/16-18 REGHEXCTRLK	2
32	324909-853	SUPPORT, STEERING/PTO	1
33	40886	SCREW, 1/4-20 X .38 WAHHTAP	4
34	324908-830	DASH, TOWER, WALK-THRU	1
35	35497	SCREW, 5/16-18 X .50 WAHHTAP	4
36	40886	SCREW, 1/4-20 X .38 WAHHTAP	2
37	304079	LENS, HEADLIGHT, SMOKE	1
38	41482	PRESS CLIP, 1.380 LONG .255 ID	2
39	330510	STEERING WHEEL	1
40	331494	SPACER, STEERING SHAFT	1
41	301413	SPACER, STEERING SHAFT	1
42	456378	PIN, SPRING .250 DIA X 2.00 LONG	1
43	308200	DECAL, REFLECTOR	1
45	12599	FASTENER, VELCRO, 2" X 1"	2
46	333120-853	BRACE, DASH TOWER, WALK-THRU	2
47	180016	SCREW, 1/4-20 X .50 HHC	2
48	46931	NUT, 1/4-20 WDFL, MAC-LOCK	2
	336315	PARTS MANUAL	1
	336350	OPERATOR'S MANUAL (ENGLISH)	1
	336351	OPERATOR'S MANUAL (FRENCH)	1
	336352	OPERATOR'S MANUAL (GERMAN)	1
	336353	OPERATOR'S MANUAL (DUTCH)	1

F3560-310

REPAIR PARTS

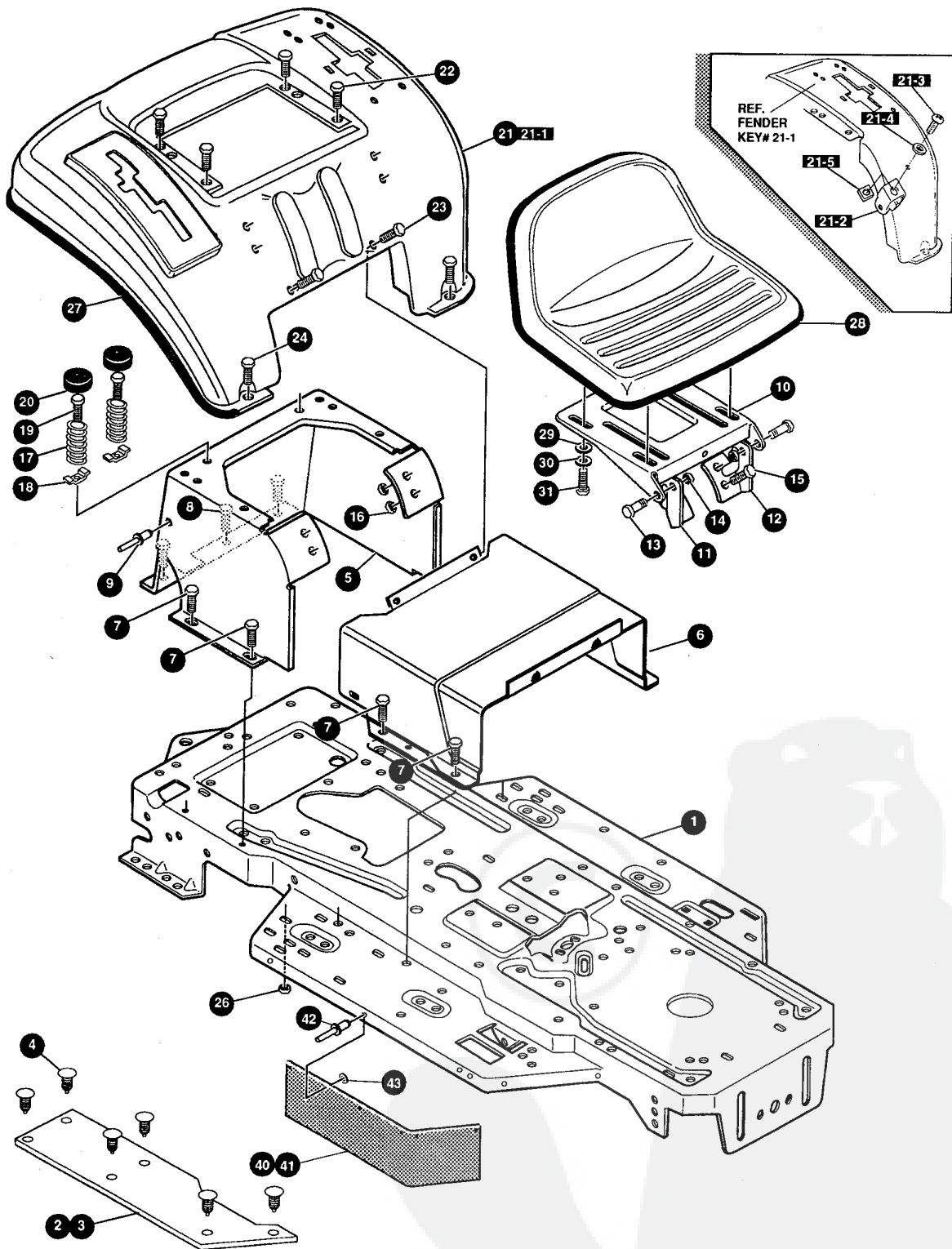

NOTE: ALWAYS USE ORIGINAL EQUIPMENT PARTS.
Use of service/replacement parts other than original equipment parts may void your warranty.

**ALL UNNUMBERED
ITEMS ARE INTERCHANGEABLE
WITH OPPOSITE SIDE**

332777 B

F3560-310

REAR CHASSIS & HOOD ASSEMBLY

KEY#	PART#	DESCRIPTION	QTY
1	335851-830	FRAME, MAIN	1
2	310005	FOOT PAD, LH, 22.12 LONG	1
3	310006	FOOT PAD, RH, 22.12 LONG	1
4	309235	FASTENER, RATCHET, BLACK	12
5	324912-830	SEAT/FENDER SUPPORT, WALK-THRU	1
6	330865-830	CONSOLE, WALK-THRU, NO SLT	1
7	995346	SCREW, 1/4-20 X .50 WAHTAP	10
8	35497	SCREW, 5/16-18 X .50 WAHTAP	2
9	46763	RIVET, POP .187 DIA X .450 LONG	3
10	58367-830	PLATE, SEAT	1
11	325053-830	BRACKET, SEAT, WALK-THRU, RH	1
12	325054-830	BRACKET, SEAT, WALK-THRU, LH	1
13	20507	BOLT, .437 X .156 HSH, 5/16-18	2
14	1498	NUT, 5/16-18 REGHEXCTRLK	2
15	48901	SCREW, 5/16-18 X .63 WAHHC	4
16	1498	NUT, 5/16-18 REGHEXCTRLK	4
17	57153	SPRING, SEAT 2.63 LONG, 1.49 OD, BLACK	2
18	1341	CLAMP, SPRING 1.17" ID	2
19	44811	SCREW, 1/4-20 X .75 WAHTAP	2
20	56907	COVER, SEAT, SPRING, 1.5 ID X 1.0 LONG	2
21	327581-860	ASSEMBLY, FENDER	1
21-1	REF. ONLY	FENDER, WALK-THRU	1
21-2	9239	CLEVIS	1
21-3	439455	SCREW, 5/16-18 X .56 PHPNMA	1
21-4	301551	WASHER, .344 ID X 1.50 D X .09	1
21-5	120373	NUT, 5/16-18 SQUARE	1
22	995346	SCREW, 1/4-20 X .50 WAHTAP	4
23	35497	SCREW, 5/16-18 X .50 WAHTAP	2
24	126358	BOLT, 5/16-18 X 1.00 CARRLN	2
26	55273	NUT, 5/16-18 WDFLLKLRG, WHIZ	2
27	55023	TRIM, STRIP, BLACK—SMALL	77.5"
28	332779	SEAT, MICHIGAN W/SW HOLE	1
29	120393	WASHER, FLAT .344 X .69 X .065	4
30	120638	WASHER, HVSPTLK .328 X .60 X .09	4
31	180077	SCREW, 5/16-18 X .75 HHC	4
40	305386	SKIRT, TUV, LF, RUBBER 7 X 28.03	1
41	305354	SKIRT, TUV, LF, RUBBER 7 X 15.64	1
42	329238	RIVET, POP 3/16 DIA X .75 LONG	10
43	1501	WASHER, FLAT .203 X .56 X .040	10

F3560-310

REPAIR PARTS

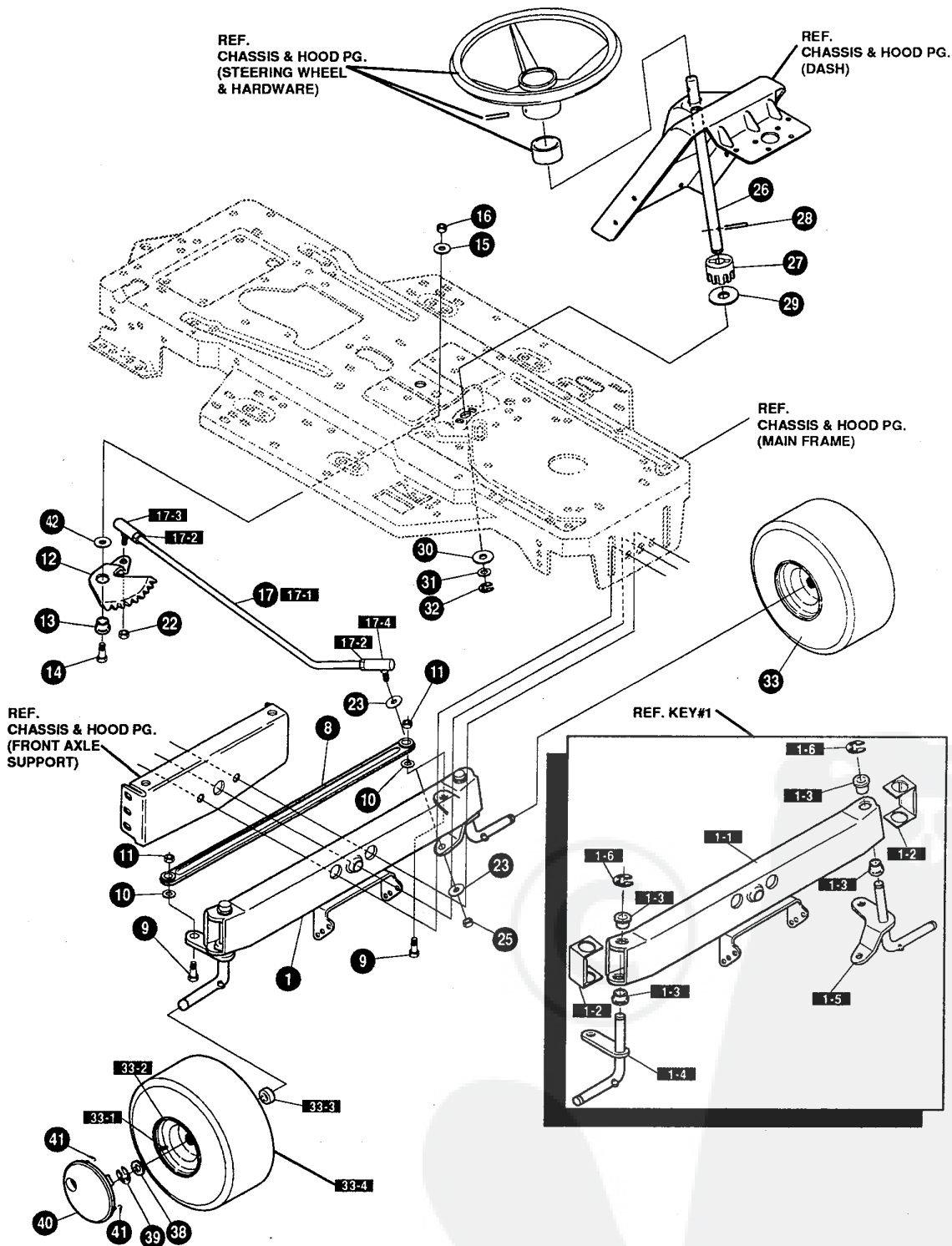

NOTE: ALWAYS USE ORIGINAL EQUIPMENT PARTS.
 Use of service/replacement parts other than original equipment parts may void your warranty.

ALL UNNUMBERED ITEMS ARE INTERCHANGEABLE WITH OPPOSITE SIDE

324171 G

F3560-310

FRONT STEERING ASSEMBLY

KEY#	PART#	DESCRIPTION	QTY
1	*	ASSEMBLY, AXLE FRONT, 4/WS, SUSP	1
1-1	310170	AXLE, FRONT	1
1-2	53373-853	AXLE COVER	2
1-3	52407	SPINDLE BEARING	4
1-4	302926	ASSEMBLY, SPINDLE, RH	1
1-5	315886	ASSEMBLY, SPINDLE, LH	1
1-6	36625	RING, RETEX .57 X .05 TRU 5133-75	2
8	304590	TIE ROD ASSEMBLY, 19.81 LONG W-SECTION	1
9	180128	SCREW, 3/8-16 X 1.75 HHC	2
10	120382	WASHER, REGSPTLK .393 X .68 X .10	2
11	1499	NUT, 3/8-16 REGHXCTRLK	2
12	58289	SECTOR, STEERING, LF	1
13	52406	BEARING, FL ECC.510 ID X .998 OD X .56	1
14	180177	SCREW, 1/2-13 X 1.50 HHC	1
15	22265	WASHER, FLAT .515 X 1.38 X .119	1
16	1500	NUT, 1/2-13 REGHCTRLK	1
17	311100	KIT 300146 DRAGLINK	1
17-1	58291	STEERING LINK	1
17-2	124925	NUT, 3/8-24 REGHEXJAM	2
17-3	57158	BALL JOINT, 3/8 THD, SHORT STUD	1
17-4	21275	BALL JOINT, 3/8 THD, LONG STUD	1
22	412349	NUT, 3/8-24 HXCTRLK	1
23	996416	WASHER, FLAT .391 X 1.00 X .125	2
25	412349	NUT, 3/8-24 HXCTRLK	1
26	58243	SHAFT, STEERING, LF, 2WS	1
27	58244	PINION, STEERING, LF	1
28	58274	PIN, DOWEL .2500 OD+1.75 LONG	1
29	301410	BEARING, FL .752 ID X 1.061 OD X .24	1
30	301398	WASHER, FORMED 1.135 X 1.53 X .12	1
31	21682	WASHER, FLAT .765 X 1.25 X .042	1
32	36625	RING, RETEX .57 X .05 TRU 5133-75	1
33	315661	TIRE & RIM ASSEMBLY, PU 15 X 6.0 X 6	2
33-1	24167	VALVE STEM	
33-2	321516	RIM, WHEEL	
33-3	314416	BEARING, FLANGE	
33-4	316702	TIRE, PU 15 X 6.0 X 6	
38	642	WASHER, FLAT .755 X 1.31 X .075	4
39	36625	RING, RETEX .57 X .05 TRU 5133-75	2
40	304444-999	HUB CAP, 6" EURO	2
41	306669	CLIP, HUBCAP TINN #C25467-017-4	8
42	49998	WASHER, FLAT .520 X 1.25 X .209	1

* ORDER INDIVIDUAL PARTS - ASSEMBLY NOT AVAILABLE

F3560-310

REPAIR PARTS

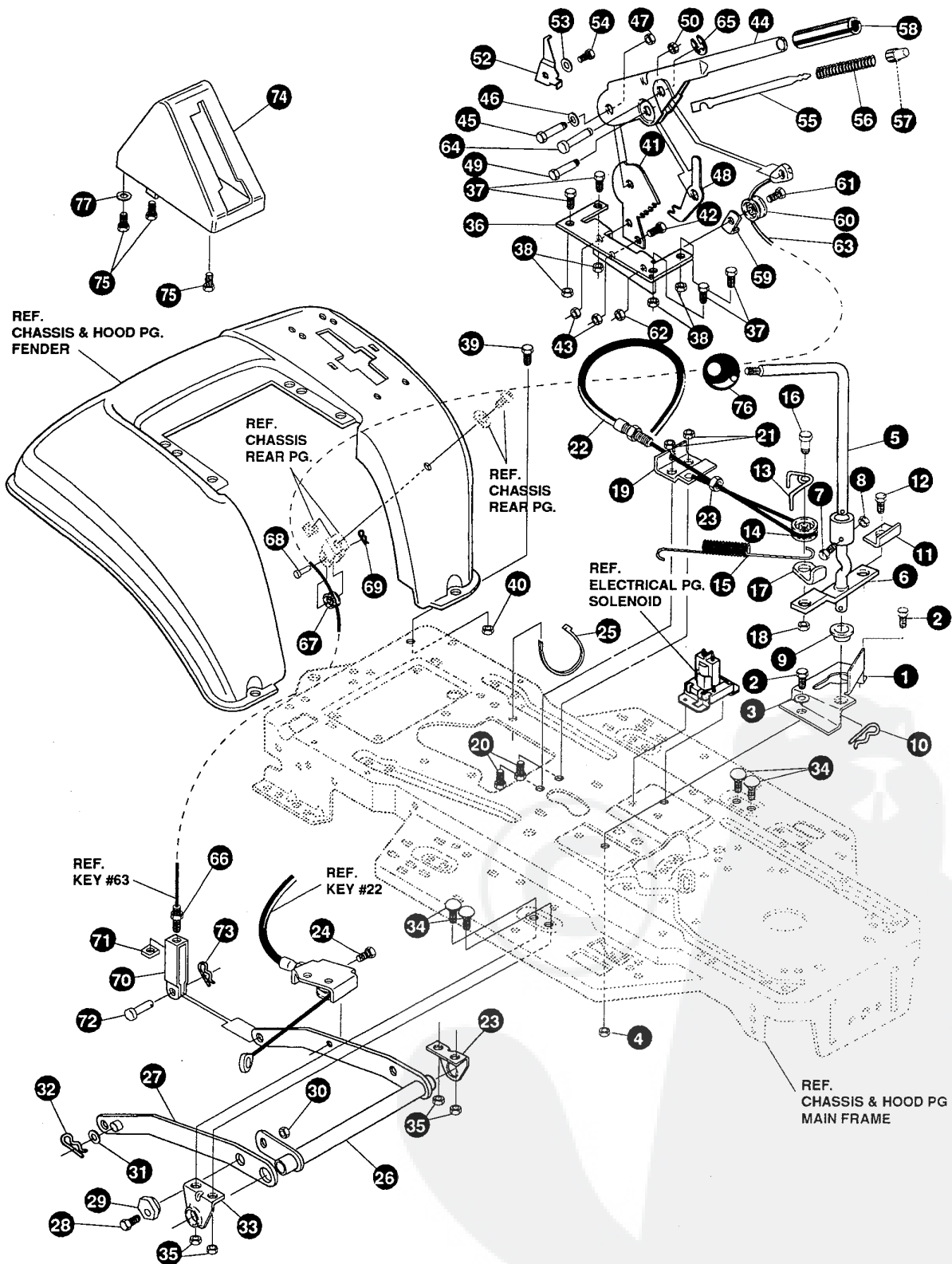

NOTE: ALWAYS USE ORIGINAL EQUIPMENT PARTS.
 Use of service/replacement parts other than original equipment parts may void your warranty.

**ALL UNNUMBERED
 ITEMS ARE INTERCHANGEABLE
 WITH OPPOSITE SIDE**

331726 C

F3560-310**MOWER SUSPENSION ASSEMBLY**

KEY#	PART#	DESCRIPTION	QTY
1	320075-853	BRACKET, CLUTCH ENGAGE LEVER	1
2	180079	SCREW, 5/16-18 X 1.00 HHC	2
3	120393	WASHER, FLAT .344 X .69 X .065	2
4	1498	NUT, 5/16-18 REGHEXCTRLK	2
5	331050	LEVER, PTO, UPPER	1
6	331727	ASSEMBLY, CLUTCH LEVER, LOWER	1
7	308231	SCREW, 1/4-20 X 1.25 HHWATAP	1
8	1502	NUT, 1/4-20 REGHEXCTRLK	1
9	50148	BEARING, FLANGE .503 ID X .63 OD X .50	1
10	8260	PIN, HAIR .091 DIA X 1.66 LONG	1
11	318341	BRACKET, SWITCH ENGAGE	1
12	35498	SCREW, 5/16-18 X .75 WAHHTAP	1
13	324032	SPRING, CABLE KEEPER .390 ID	1
14	48306	PULLEY, POWDER METAL	1
15	316648	SPRING .071 X .62 X 12.88	1
16	324045	BOLT, .375 X .565 HSSH	1
17	1288	BRACKET, CABLE RETAINER	1
18	1502	NUT, 1/4-20 REGHEXCTRLK	1
19	300698-853	BRACKET FRAME CABLE	1
20	180020	SCREW, 1/4-20 X .75 HHC	2
21	1502	NUT, 1/4-20 REGHEXCTRLK	2
22	324055	ASSEMBLY, CABLE, BLADE ENGAGE	1
23	120613	NUT, 1/4-28 HJAM	1
24	35498	SCREW, 5/16-18 X .75 WAHHTAP	1
25	57444	TIE, CABLE BLACK NYLON, 5.62 LONG	1
26	300158-853	LIFT ASSEMBLY, LH	1
27	300169-853	LIFT ASSEMBLY, RH	1
28	180079	SCREW, 5/16-18 X 1.00 HHC	1
29	58247	NUT, ADJUST	1
30	1498	NUT, 5/16-18 REGHEXCTRLK	1
31	417098	WASHER, FLAT .531 X 1.06 X .063	2
32	8260	PIN, HAIR .091 DIA X 1.66 LONG	2
33	58248-853	BRACKET, REAR HANG, SUSP	2
34	57072	BOLT, 5/16-18 X .63 CARRLN	4
35	1498	NUT, 5/16-18 REGHEXCTRLK	4
36	313926	BRACKET, HEIGHT/ADJUST SUPPORT	1
37	180077	SCREW, 5/16-18 X .75 HHC	4
38	1498	NUT, 5/16-18 REGHEXCTRLK	4
39	180077	SCREW, 5/16-18 X .75 HHC	1
40	1498	NUT, 5/16-18 REGHEXCTRLK	1
41	301238	QUADRANT, HEIGHT ADJUST	1
42	180077	SCREW, 5/16-18 X .75 HHC	2
43	1498	NUT, 5/16-18 REGHEXCTRLK	2
44	322292-853	HANDLE, LIFT SHORT	1
45	300171	BOLT, .500X .270 HSSH, 5/16-18	1
46	996418	WASHER, FLAT .506 X .75 X .024	1
47	44108	NUT, 5/16-18 HWDFLCTRLK	1
48	301239	PAWL, SQUARE	1
49	300171	BOLT, .500 X .270 HSSH, 5/16-18	1
50	44108	NUT, 5/16-18 HWDFLCTRLK	1
52	9435	POINTER, HEIGHT ADJUST	1
53	138479	WASHER, EXLK .195 X .41 X .03	1
54	35287	SCREW, #8-32 X .38 HHWATAP	1
55	303027	ROD, ACTUATOR-SHORT	1
56	58326	SPRING, HEIGHT ADJUST	1
57	58325	KNOB, HEIGHT ADJUST PUSH BUTTON	1
58	58329	GRIP, .750 OD W/ HOLE BLACK	1
59	9149	BRACKET, CABLE RETAINER	1
60	48306	PULLEY, POWDER METAL	1
61	58336	BOLT, .375 X .375 HSSH, 1/4-20	1
62	1502	NUT, 1/4-20 REGHEXCTRLK	1
63	314177	CABLE, LIFT, 22.92	1
64	300310	PIN, CLEVIS .310 DIA+ .475 LONG	1
65	300311	RING, RET E .31 X .25 TRU 5133-31	1
66	120375	NUT, 1/4-20 REGHEX	1
67	48306	PULLEY, POWDER METAL	1
68	300317	PIN, CLEVIS .375 DIA X .81 LONG	1
69	8260	PIN, HAIR .091 DIA X 1.66 LONG	1
70	9405	CLEVIS, LIFT CABLE	1
71	120372	NUT, 1/4-20 REGSQ	1
72	39522	PIN, CLEVIS .312 X .812	1
73	121222	PIN, COTTER .090 DIA X .75 LONG	1
74	333903	LIFT COVER	1
75	300340	SCREW, #10 X .75 HHPLAST	3
76	321837	KNOB, ROUND 1.50 DIA MATTE	1
77	120392	WASHER, FLAT .281 X .63 X .065	1

F3560-310

REPAIR PARTS

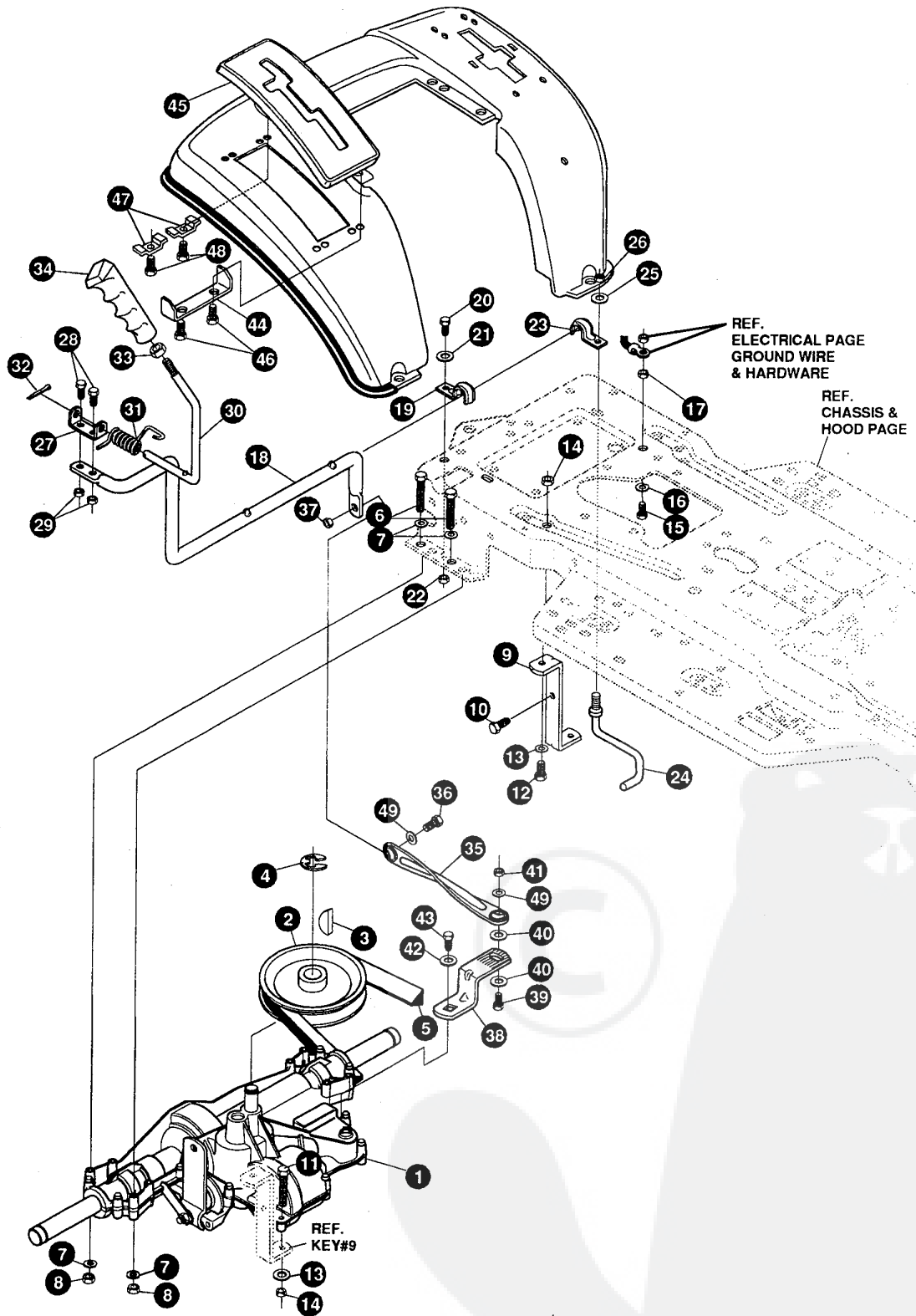

NOTE: ALWAYS USE ORIGINAL EQUIPMENT PARTS.
Use of service/replacement parts other than original equipment parts may void your warranty.

**ALL UNNUMBERED
ITEMS ARE INTERCHANGEABLE
WITH OPPOSITE SIDE**

326605 E

F3560-310

MOTION DRIVE ASSEMBLY

KEY#	PART#	DESCRIPTION	QTY
1	*	TRANSAXLE, P940-6	1
2	302745	PULLEY, 6.6 OD, V4L, T/A	1
3	50795	KEY, HI-PRO 606 .75 DIA X .187 WD	1
4	22053	RING, RETEX .58 X .035 TRU 5100-62	1
5	314120	BELT, V 4L, 87.25	1
6	180091	SCREW, 5/16-18 X 2.50 HHC	4
7	120393	WASHER, FLAT .344 X .69 X .065	8
8	1498	NUT, 5/16-18 REGHEXCTRLK	4
9	325202	BRACKET, STABILIZER	1
10	50947	SCREW, 3/8-16 X 1.25 WAHTAP	1
11	180087	SCREW, 5/16-18 X 2.00 HHC	2
12	180079	SCREW, 5/16-18 X 1.00 HHC	1
13	120393	WASHER, FLAT .344 X .69 X .065	2
14	1498	NUT, 5/16-18 REGHEXCTRLK	2
15	180077	SCREW, 5/16-18 X .75 HHC	1
16	138538	WASHER, REGINTLK .320 X .61 X .03	1
17	1498	NUT, 5/16-18 REGHEXCTRLK	1
18	330462	LEVER, SHIFT-LOWER	1
19	310347-853	CLIP- SHIFT LEVER, .625 ROD	1
20	180077	SCREW, 5/16-18 X .75 HHC	1
21	996416	WASHER, FLAT .391 X 1.00 X .125	1
22	1498	NUT, 5/16-18 REGHEXCTRLK	1
23	310347-853	CLIP- SHIFT LEVER, .625 ROD	1
24	57259	GUIDE, BELT 5/16-18 THD	1
25	996416	WASHER, FLAT .391 X 1.00 X .125	1
26	1498	NUT, 5/16-18 REGHEXCTRLK	1
27	310356	BRACKET, PIVOT, SHIFT LEVER	1
28	180020	SCREW, 1/4-20 X .75 HHC	2
29	1502	NUT, 1/4-20 REGHEXCTRLK	2
30	324798	LEVER, SHIFT, UPPER SOF, 1/2-13	1
31	310265	SPRING, TORSION, .56 X .95 X .095	1
32	137185	PIN, COTTER .125 DIA X 1.00 LONG	1
33	120238	NUT, 1/2-13 HEXJAM	1
34	306690	HANDLE, 1/2-13	1
35	325192	LINK, TIE ROD, SHIFT	1
36	180124	SCREW, 3/8-16 X 1.25 HHC	1
37	1499	NUT, 3/8-16 REGHXCTRLK	1
38	327460	BRACKET, SHIFT, FENDER	1
39	180124	SCREW, 3/8-16 X 1.25 HHC	1
40	120394	WASHER, FLAT .406 X .81 X .065	2
41	1499	NUT, 3/8-16 REGHXCTRLK	1
42	57157	WASHER, .750 X .250 SP-TRANSAXLE	1
43	56255	SCREW, 1/4-28 X .75 NYLHHC	1
44	311257-853	BRACKET, COVER, FENDER, SHIFT	1
45	311209	COVER, PLASTIC	1
46	311331	SCREW, 1/4-15 X .44/.53 HILOHHWA	2
47	1341	CLAMP, SPRING 1.17"ID	2
48	311331	SCREW, 1/4-15 X .44/.53 HILOHHWA	2
49	120394	WASHER, FLAT .406 X .81 X .065	2

* CONTACT YOUR NEAREST TRANSAXLE DEALER FOR PARTS & SERVICE

F3560-310

REPAIR PARTS

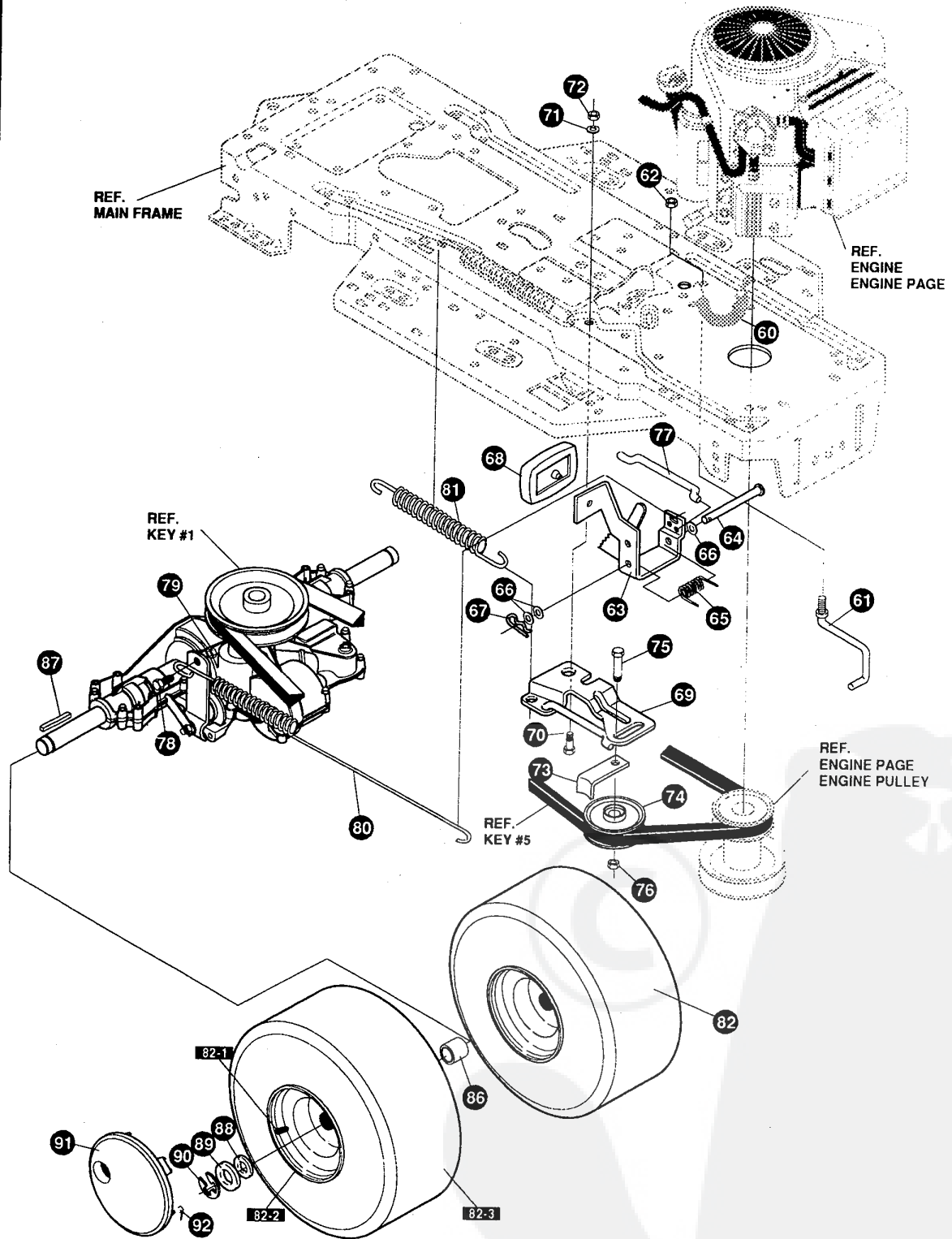

NOTE: ALWAYS USE ORIGINAL EQUIPMENT PARTS.
Use of service/replacement parts other than original equipment parts may void your warranty.

**ALL UNNUMBERED
ITEMS ARE INTERCHANGEABLE
WITH OPPOSITE SIDE**

326605 E

F3560-310**MOTION DRIVE ASSEMBLY**

KEY#	PART#	DESCRIPTION	QTY
60	321514	SPRING, DRAG LINK BIAS	1
61	304016	GUIDE, BELT, RH	1
62	1498	NUT, 5/16-18 REGHEXCTRLK	1
63	325942	PEDAL ASSEMBLY, BRAKE/CLUTCH	1
64	319675	PIN, CLEVIS .500 D X 4.53 LONG	1
65	57847	SPRING, BRAKE PEDAL	1
66	2968	WASHER, FLAT .504 X .75 X .059	3
67	56180	PIN, HAIR .091 DIA X 1.62 LONG	1
68	48160	PAD, CLUTCH BRAKE, W/PRINTING	1
69	320381	ARM, IDLER TRACTION	1
70	329989	BOLT, .625 X .135 HSSH, 5/16-18	1
71	45602	WASHER, FLAT .333 X .87 X .119	1
72	1498	NUT, 5/16-18 REGHEXCTRLK	1
73	39659	RETAINER, BELT	1
74	35374	PULLEY, IDLER, V4L, 3.06 X .62	1
75	45892	BOLT, 3/8-16 X 1.50 CARRSN	1
76	1499	NUT, 3/8-16 REGHXCTRLK	1
77	57204	ROD, CLUTCH 3.92"	1
78	326131	BOLT, .495 X .31 HSSH, 5/16-18	1
79	1498	NUT, 5/16-18 REGHEXCTRLK	1
80	325910	SPRING, BRAKE, 31.12	1
81	330505	SPRING, CLUTCH .113 X .750 X 8.75	1
82	305362	TIRE & RIM, 20 X 10.00-8	2
82-1	24167	VALVE STEM	
82-2	301366	RIM, WHEEL	
82-3	319686	TIRE & RIM 20 X 10.00-8	
86	301565	SPACER, SLEEVE .750 X 1.25 X .50	2
87	52928	KEY, SQUARE .187 SQUARE X 2.25 LONG	2
88	642	WASHER, FLAT .755 X 1.31 X .075	4
89	42815	WASHER, FLAT .755 X 1.53 X .07	2
90	36625	RING, RETEX .57 X .05 TRU 5133-75	2
91	304441	HUB CAP, 8"	2
92	306669	CLIP, HUBCAP TINN #C25467-017-4	10

F3560-310

REPAIR PARTS

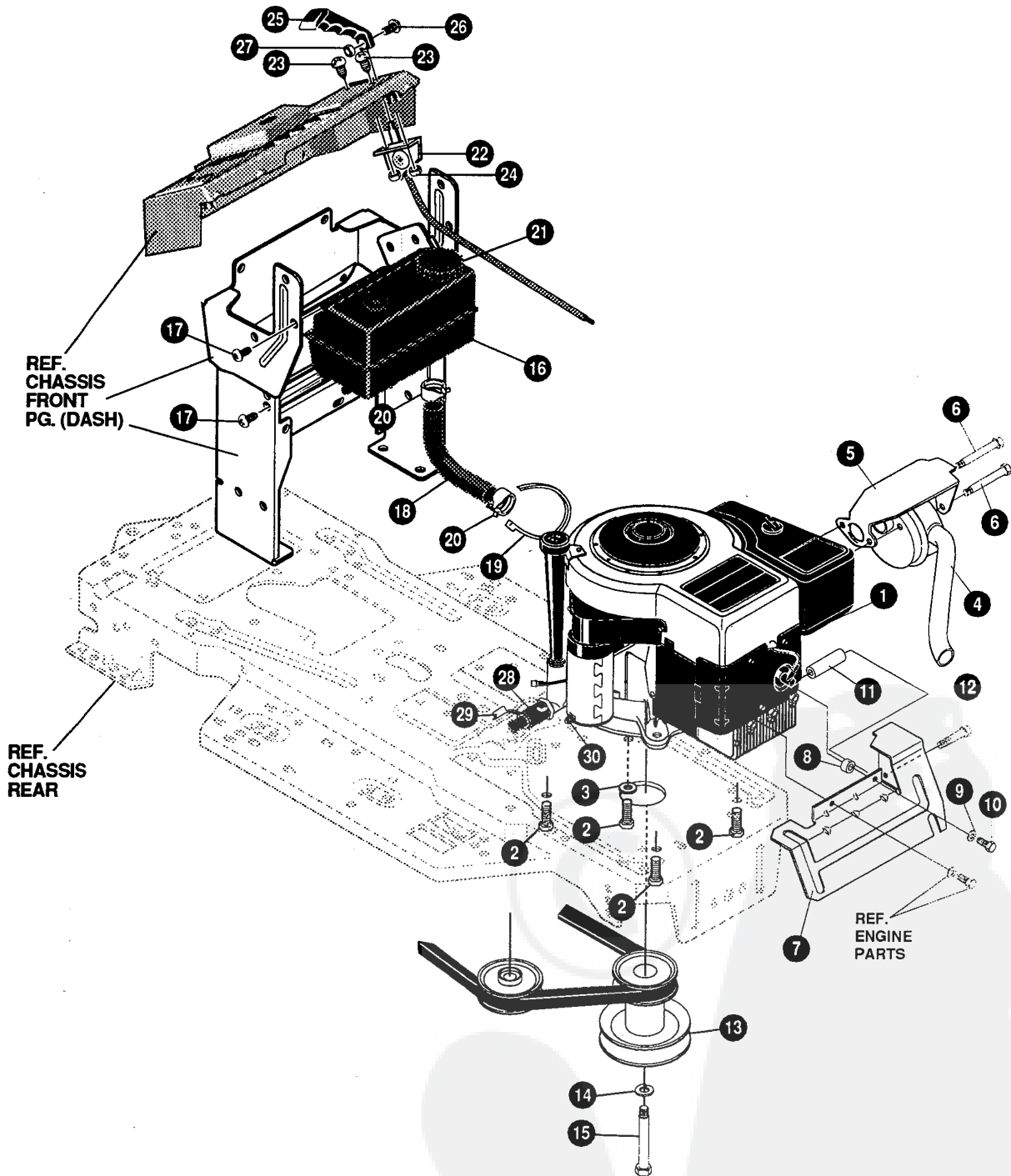

NOTE: ALWAYS USE ORIGINAL EQUIPMENT PARTS.
Use of service/replacement parts other than original equipment parts may void your warranty.

**ALL UNNUMBERED
ITEMS ARE INTERCHANGEABLE
WITH OPPOSITE SIDE**

331938 B

F3560-310

ENGINE & CONTROL ASSEMBLY

KEY#	PART#	DESCRIPTION	QTY
1	*	ENGINE, 12-12.5HP, B&S, IC, DUAL.....	1
2	50947	SCREW, 3/8-16 X 1.25 WAHHTAP.....	4
3	138489	WASHER, EXLK .384 X .69 X .04.....	1
4	310284	MUFFLER, ROUND, 12HP, 5" DIA.....	1
5	305409	SHIELD, MUFFLER, B&S, SQ. LO-TONE.....	1
6	305407	BOLT, .437 X 4.340 HSSH, 5/16-18.....	2
7	331816-853	SHIELD, HEAT, 12HP, 5" MUFFLER.....	1
8	41462	SPACER, SLEEVE .328 X .75 X .312.....	1
9	120380	WASHER, REGSPTLK .263 X .49 X .07.....	1
10	180022	SCREW, 1/4-20 X 1.00 HHC.....	1
11	310292	SPACER, SLEEVE .28 X .38 X 3.12.....	1
12	189293	SCREW, 1/4-20 X 3.50 HHC.....	1
13	328028	PULLEY, ENGINE 3.0D X 4.0 LONG X 5.0D.....	1
14	120383	WASHER, REGSPTLK .459 X .78 X .12.....	1
15	433146	SCREW, 7/16-20 X 4.25 HHC, BLACK.....	1
16	309853	TANK, FUEL 1.5, WO/SENSOR CLEAR.....	1
17	49050	SCREW, 1/4-10 X .75 PHPNTAP.....	4
18	50118	TUBING, .25 X .50 X BULK GAS LINE.....	13.5"
19	57444	TIE, CABLE BLACK NYLON, 5.62 LONG.....	1
20	336890	CLAMP, HOSE SCREW TYPE.....	2
21	12501	CAP, FUEL 2.5" THROAT.....	1
22	315716	THROTTLE CONTROL, 17.0" CHKOMA.....	1
23	320553	SCREW, 10-24 X .63 PHPNMA.....	2
24	308459	NUT, #10-24 HXHDNYLK.....	2
25	300508	KNOB, THROTTLE CONTROL. GP STYLE.....	1
26	159585	SCREW, #8-32 X .38 PHPNMA.....	1
27	120622	NUT, #8-32 REGHX.....	1
28	NO PART REQ'D	OIL DRAIN VALVE ASSEMBLY.....	1
29	NO PART REQ'D	CAP, OIL DRAIN VALVE ASSEMBLY, YELLOW.....	1
30	124818	NUT, 1/4-20 REGHXJAM.....	1

* SEE ENGINE MANUAL

F3560-310

REPAIR PARTS

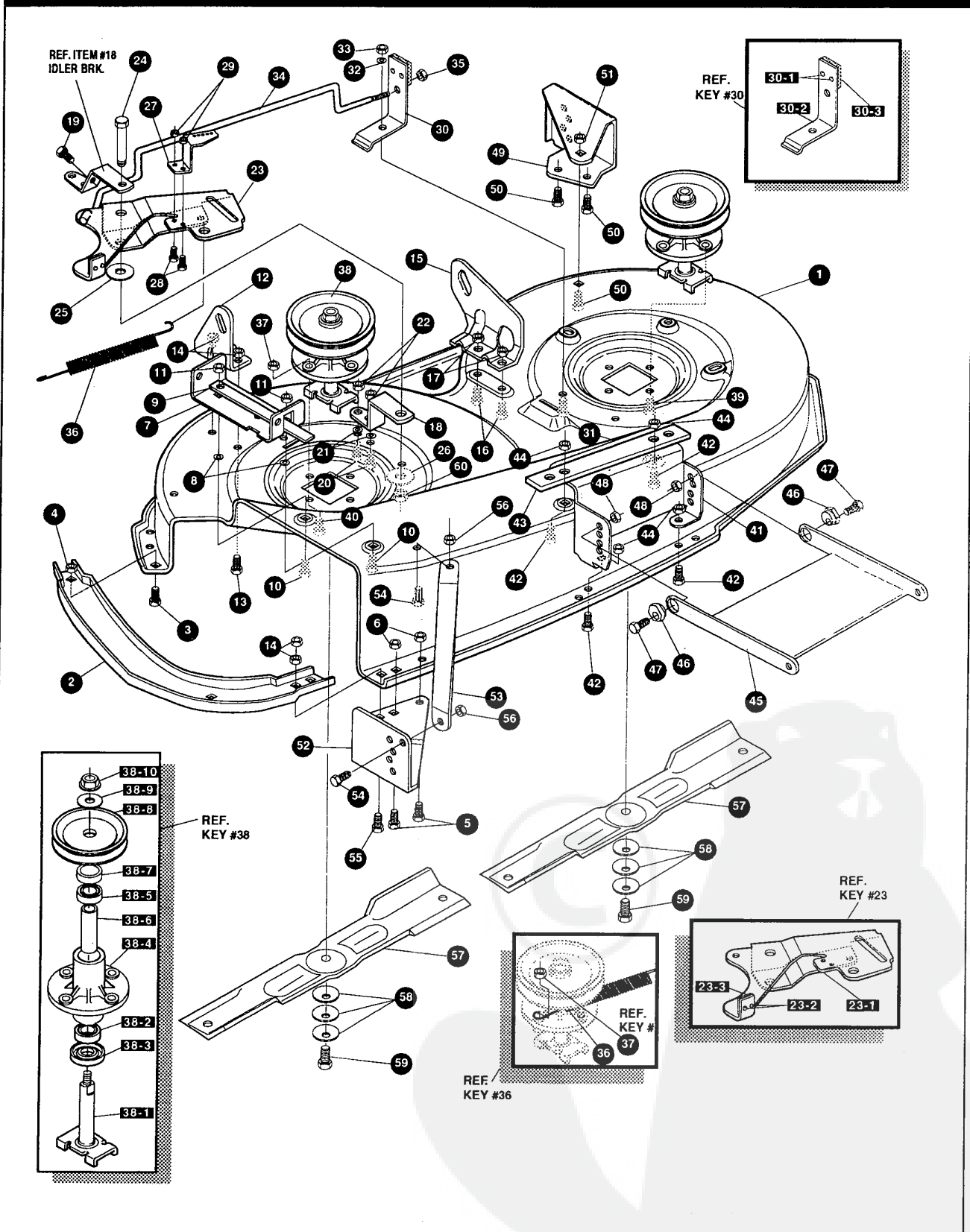

NOTE: ALWAYS USE ORIGINAL EQUIPMENT PARTS.
Use of service/replacement parts other than original equipment parts may void your warranty.

ALL UNNUMBERED ITEMS ARE INTERCHANGEABLE WITH OPPOSITE SIDE

331147 D

F3560-310

PRE-PAINTED DECK ASSEMBLY

KEY#	PART#	DESCRIPTION	QTY
1	325103	40" DECK KIT	1
2	326480-853	TOE GUARD - MULCHER	1
3	180077	SCREW, 5/16-18 X .75 HHC	1
4	1498	NUT, 5/16-18 REGHEXCTRLK	1
5	180077	SCREW, 5/16-18 X .75 HHC	1
6	1498	NUT, 5/16-18 REGHEXCTRLK	2
7	317017	BRACKET, CHUTE MOUNT, BLACK	1
8	120393	WASHER, FLAT .344 X .69 X .065	2
9	322320	LEVER ASSEMBLY (SHORT)	1
9-1	58319	PIN	1
9-2	322319	LEVER, CHUTE LATCH (SHORT)	1
10	180077	SCREW, 5/16-18 X .75 HHC	2
11	1498	NUT, 5/16-18 REGHEXCTRLK	2
12	313929	LIFT BRACKET, REAR, RH	1
13	180077	SCREW, 5/16-18 X .75 HHC	2
14	1498	NUT, 5/16-18 REGHEXCTRLK	2
15	310667	BRACKET, DECK, LIFT, REAR, LH	1
16	180077	SCREW, 5/16-18 X .75 HHC	2
17	1498	NUT, 5/16-18 REGHEXCTRLK	2
18	326893-853	BRACE, IDLER SUPPORT	1
19	308231	SCREW, 1/4-20 X 1.25 HHWTAP	1
20	180077	SCREW, 5/16-18 X .75 HHC	2
21	120393	WASHER, FLAT .344 X .69 X .065	2
22	44108	NUT, 5/16-18 HWDFLCTRLK	2
23	320576-853	IDLER ARM ASSEMBLY	1
23-1	322116-853	ARM, IDLER	1
23-2	41601	RIVET, OVSET .187 DIA X .50 LONG	2
23-3	306973	BRAKE PAD - HARD-NF343 (X-31)	1
24	304420	BOLT, .500 X 2.15 HSSH	1
25	996307	WASHER, FLAT .391 X 1.00 X .209	1
26	996416	WASHER, FLAT .391 X 1.00 X .125	2
27	326249-853	BRACKET, EXTENSION, IDLER	1
28	180077	SCREW, 5/16-18 X .75 HHC	2
29	1498	NUT, 5/16-18 REGHEXCTRLK	2
30	321828	BLADE BRAKE ASSEMBLY	1
30-1	135624	RIVET, TRSET .185 DIA X .41 LONG	2
30-2	304119-853	BRAKE ARM	1
30-3	306973	BRAKE PAD - HARD-NF343 (X-31)	1
31	180077	SCREW, 5/16-18 X .75 HHC	1
32	120393	WASHER, FLAT .344 X .69 X .065	1
33	1498	NUT, 5/16-18 REGHEXCTRLK	1
34	315396	ROD, BRAKE, 40" DECK	1
35	1502	NUT, 1/4-20 REGHEXCTRLK	1
36	35410	SPRING, .071 X .62 X 4.37	1
37	1498	NUT, 5/16-18 REGHEXCTRLK	1
38	56424-853	QUILL ASSEMBLY	2
38-1	56425	SHAFT/SADDLE	1
38-2	49562	BEARING, BALL 6203-2AA-C3, ARMORED	1
38-3	50616	DUST SHIELD	1
38-4	55547	QUILL CASTING (1046)	1
38-5	49562	BEARING, BALL 6203-2AA-C3, ARMORED	1
38-6	50818	SPACER, SLEEVE .669 X .88 X 3.797	1
38-7	51449	SPACER, SLEEVE .672 X .93 X .438	1
38-8	313898	PULLEY ASSEMBLY	1
38-9	56365	WASHER, SPECIAL QUILL	1
38-10	1282	NUT, 7/16-20 WDFLLK	1
39	35498	SCREW, 5/16-18 X .75 WAHHTAP	7
40	300345	SCREW, 5/16-18 X 1.38 WAHHTAP	1
41	318445-853	BRACKET, 40", LF, FRONT, DECK	1
42	180077	SCREW, 5/16-18 X .75 HHC	4
43	328155-853	PLATE-MOUNTING	1
44	1498	NUT, 5/16-18 REGHEXCTRLK	4
45	58305-853	BRACKET, LINK, DECK, FRONT	1
46	58247	NUT, ADJUSTING	2
47	180079	SCREW, 5/16-18 X 1.00 HHC	2
48	1498	NUT, 5/16-18 REGHEXCTRLK	2
49	317041-853	BRACKET, GAUGE WHEEL, LH	1
50	180077	SCREW, 5/16-18 X .75 HHC	3
51	1498	NUT, 5/16-18 REGHEXCTRLK	3
52	322464-853	BRACKET, GAUGE WHEEL, RH, FRONT	1
53	314282-853	BRACKET, STABILIZER	1
54	180077	SCREW, 5/16-18 X .75 HHC	1
55	12685	SCREW, 5/16-18 X 1.50 HHCFT	1
56	1498	NUT, 5/16-18 REGHEXCTRLK	1
57	313316-853	BLADE, 40" STD-LIFT, 20.32	2
58	2483	WASHER, .39 ID X 1.25 D X .07 BELLVIL	6
59	39573	SCREW, 3/8-24 X 1.00 NYLHHC	2
60	45171	NUT, 3/8-16 HWDFL, WHIZ-LOCK	1

F3560-310

REPAIR PARTS

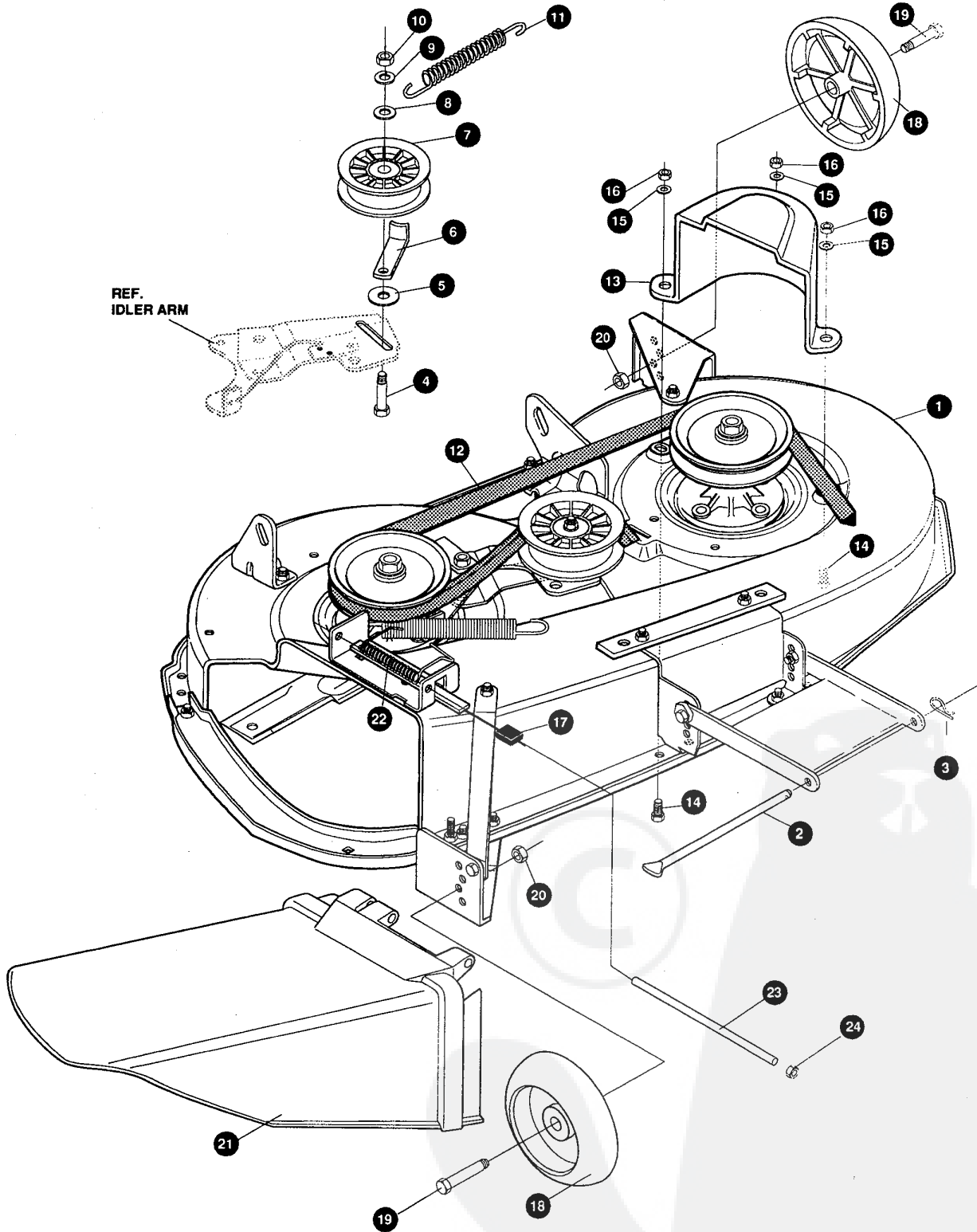

NOTE: ALWAYS USE ORIGINAL EQUIPMENT PARTS.
Use of service/replacement parts other than original equipment parts may void your warranty.

**ALL UNNUMBERED
ITEMS ARE INTERCHANGEABLE
WITH OPPOSITE SIDE**

331145 B

F3560-310

FINAL DECK ASSEMBLY

KEY#	PART#	DESCRIPTION	QTY
1	329035	ASSEMBLY, 40", DECK FOR AIR ASSIST	1
2	58306	ROD, DECK HITCH	1
3	8260	PIN, HAIR .091 DIA X 1.66 LONG	1
4	57325	BOLT, 3/8-16 X 2.00 CARRSN	1
5	25210	WASHER, FLAT .386 X 1.25 X .09	1
6	1346	RETAINER, BELT	1
7	310326	PULLEY, IDLER BFF, 4.00, WIDE FLANGE	1
8	996307	WASHER, FLAT .391 X 1.00 X .209	1
9	120382	WASHER, REGSPTLK .393 X .68 X .10	1
10	120377	NUT, 3/8-16 REGHX	1
11	300473	SPRING, TENSION, 7.52 LONG+17 LB/IN	1
12	319005	BELT, V 5L, 81.00, DECK, 40", LF	1
13	328257	GUARD, BELT, LH, PLASTIC	1
14	180077	SCREW, 5/16-18 X .75 HHC	3
15	120393	WASHER, FLAT .344 X .69 X .065	3
16	1498	NUT, 5/16-18 REGHEXCTRLK	3
17	42348	GRIP-LEVER, GRASS COLLECTOR	1
18	302611	GAUGE WHEEL, EURO, 6.00 OD X 1.38 WD	2
19	23763	BOLT, .500 X 1.390 HSSH, 3/8-16	2
20	1499	NUT, 3/8-16 REGHXCTRLK	2
21	304422	CHUTE DEFLECTOR, 40", 42" & 43"	1
22	314975	SPRING, TORSION, CHUTE DEFLECTOR	1
23	304424	ROD, PIVOT DECK .312 D X 7.25	1
24	3535	NUT, PUSH ON CAP .312 OD	1

F3560-310

REPAIR PARTS

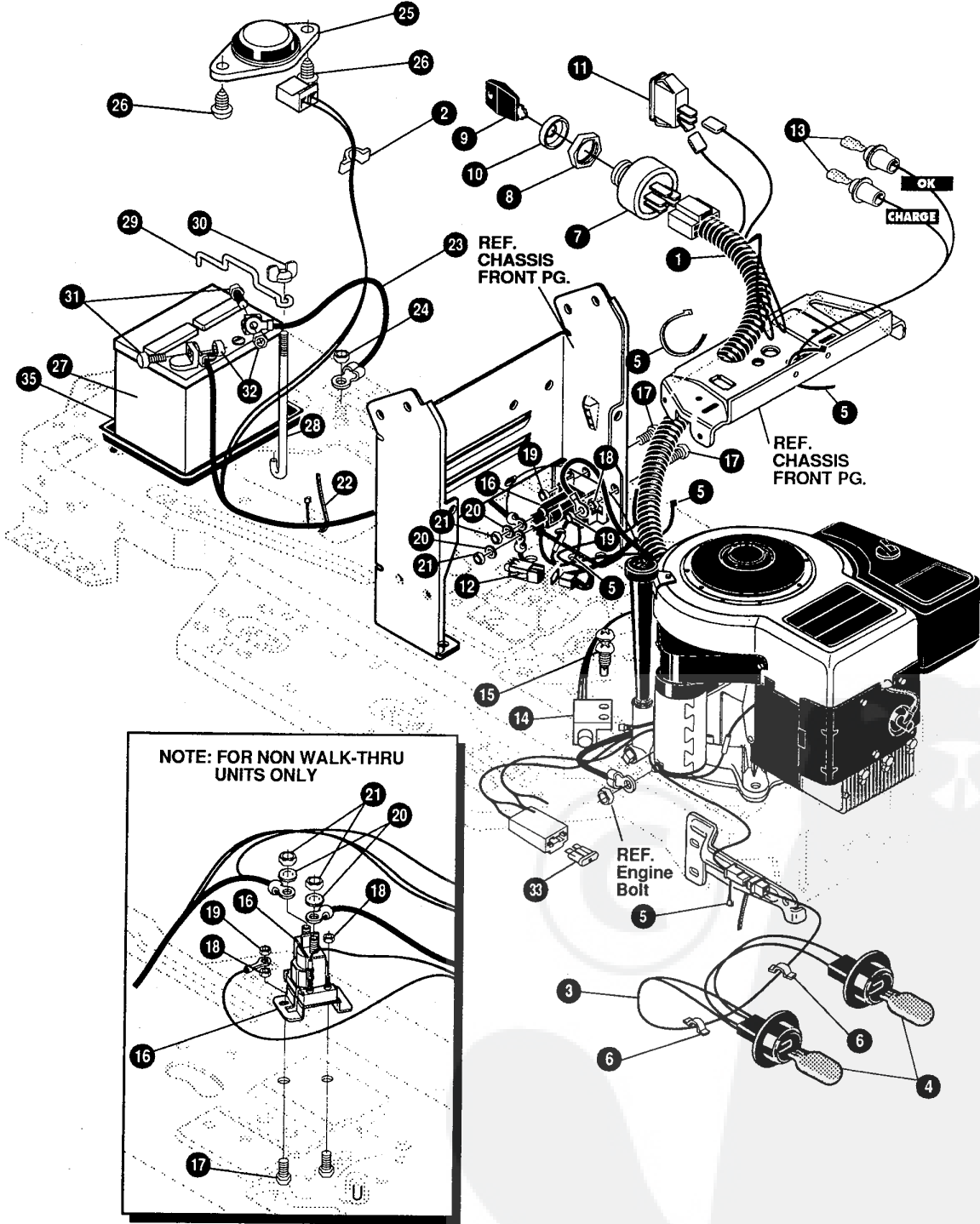

NOTE: FOR NON WALK-THRU UNITS ONLY

NOTE: ALWAYS USE ORIGINAL EQUIPMENT PARTS.
Use of service/replacement parts other than original equipment parts may void your warranty.

ALL UNNUMBERED ITEMS ARE INTERCHANGEABLE WITH OPPOSITE SIDE

332732 C

F3560-310

ELECTRICAL ASSEMBLY

KEY#	PART#	DESCRIPTION	QTY
1	331395	HARNES, 12.5HP, B&S, EURO 1&2, LF, SUS	1
2	41482	PRESS CLIP, 1.380 LONG .255 ID	1
3	303064	ASSEMBLY, LIGHT WIRE-1/4 TURN	1
4	52572	BULB, HEADLAMP	2
5	57444	TIE, CABLE BLACK NYLON, 5.62 LONG	5
6	41482	PRESS CLIP, 1.380 LONG .255 ID	3
7	327355	SWITCH-IGNITION (AFTER FIRE) 3 POSITION	1
8	327352	NUT, 5/8-8 ACME DELTA FOR BOOT	1
9	327350	KEY, IGNITION	2
10	300194	BOOT, IGNITION SWITCH	1
11	328826	LIGHT SWITCH, PANEL MOUNT	1
12	320082	SWITCH, DOUBLE POLE, NO/NC GRAY	1
13	57769	BULB, INDICATOR	2
14	57476	SWITCH, SCREW MOUNT, DP, NC, NO, BLACK	1
15	57220	SCREW, #12 X .50 PHPNHTAP, BLACK	2
16	53716	SOLENOID	1
17	187745	SCREW, 1/4-20 X .75 HXSEMMA	2
18	1502	NUT, 1/4-20 REGHEXCTRLK	2
19	271172	NUT, 1/4-20 REGHEXKEPS	1
20	138485	WASHER, EXLK .320 X .61 X .03	2
21	120368	NUT, 5/16-24 REGHEX	2
22	57444	TIE, CABLE BLACK NYLON, 5.62 LONG	1
23	55511	WIRE, GROUND, 12.5"	1
24	271184	NUT, 5/16-18 HEXKEPS	1
25	57547	SWITCH, SEAT	1
26	160505	SCREW, 1/4-20 X .38 PHPNHMA	2
27	302257	BATTERY, 12V	1
28	57551	ROD, BATTERY	1
29	57552	ROD, BATTERY, TOP	1
30	325232	NUT, WING 1/4-20 NYLON	1
31	180020	SCREW, 1/4-20 X .75 HHC	2
32	271172	NUT, 1/4-20 REGHEXKEPS	2
35	91895	TRAY - BATTERY	1

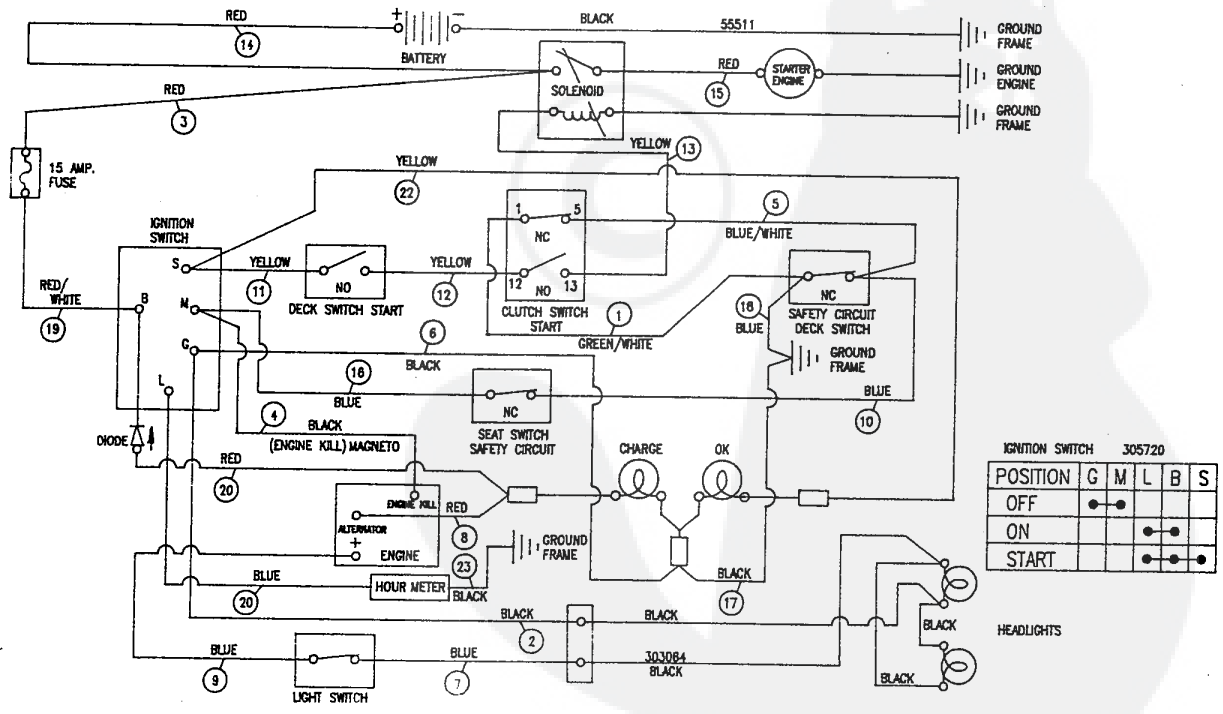

F3560-310

REPAIR PARTS

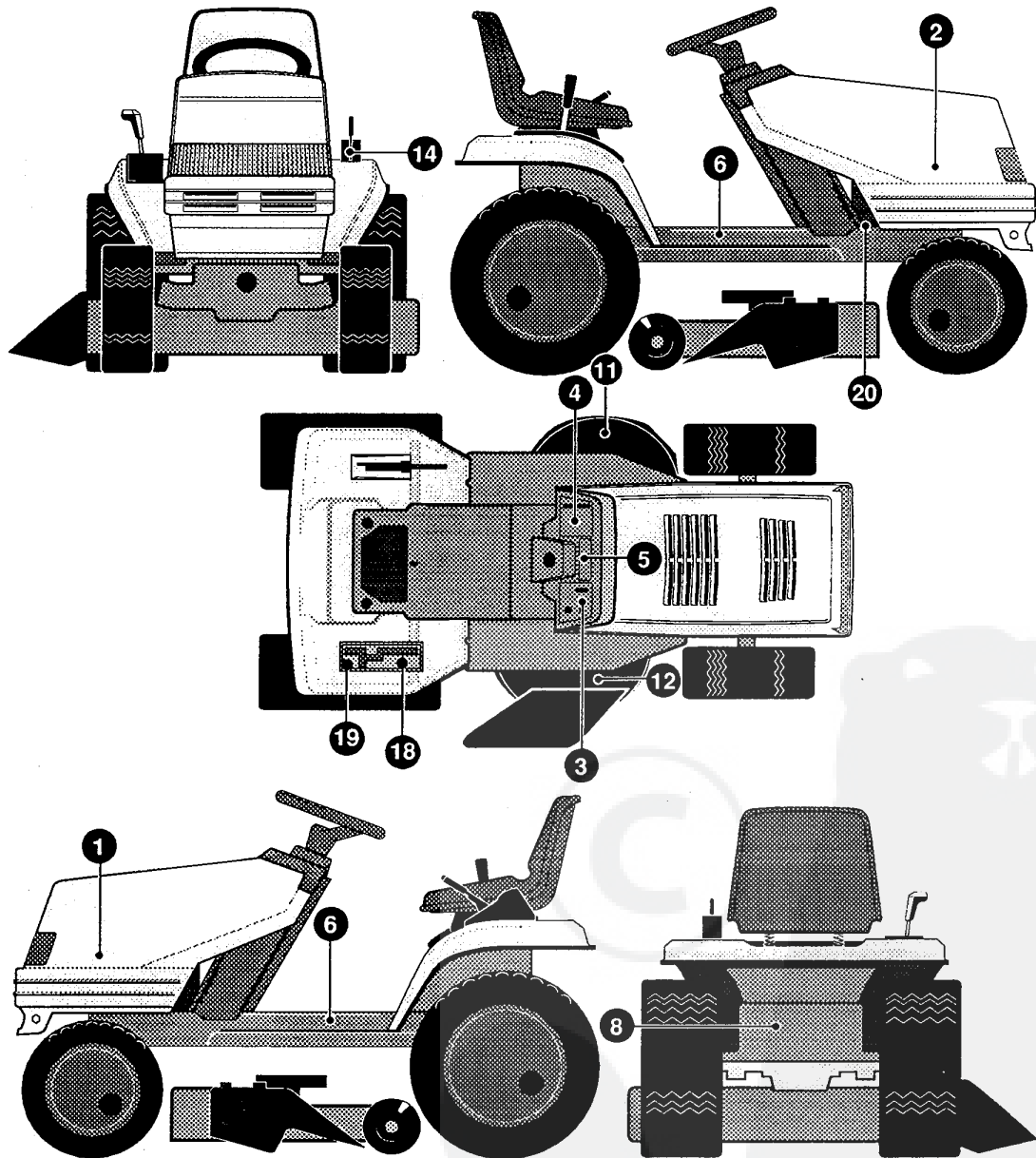

334981 B

KEY#	PART#	DESCRIPTION	QTY
1	402387	DECAL, STATESMAN, HOOD, H-16	1
2	402388	DECAL, STATESMAN, HOOD, H-16	1
3	332805	DECAL, DASH, RH, ISO, ENG, N/HR,CHK	1
4	315765	DECAL, DASH, LH, ISO, CHOKE-O-MATIC	1
5	324934	DECAL, DASH, ALL SYS, CHRG DIODE	1
6	402382	NAMEPLATE, 12.5/40 (CHROME)	2
10	402689	DECAL, CONSOLE, SYMBOLIC, CAUTION	1
11	402700	DECAL, CAUTION DECK, LH	1
12	402701	DECAL, CAUTION DECK, RH	1
14	402214	DECAL, HEIGHT ADJUST	1
18	331007	DECAL, SHIFTER POSITION	1
19	311394	DECAL, SHIFT REVERSE/NEUTRAL	1
20	402702	DECAL, BRAKE/CLUTCH	1

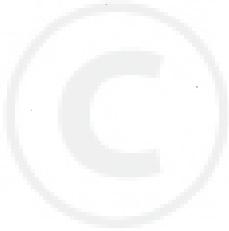

ACCESSORIES

Contact the dealer where your tractor was purchased for the available accessories. If you are unable to contact the dealer, write to the address on the warranty page of this manual.

Large Lawn Tractor

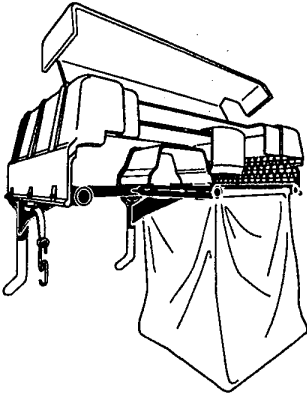

Model # 5708-34
Grass Collector for
40, 42, 43" decks

For heavy duty grass
collection order Model
#5709-10 Air Assist

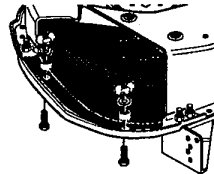

5717-00
Mulching Kit (42/43" Deck)
5716-00
Mulching Kit (40" Deck)

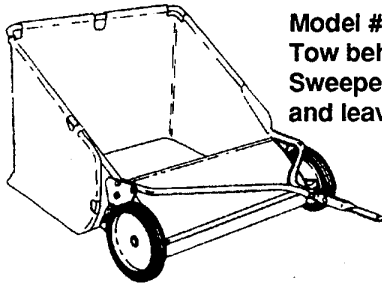
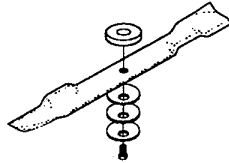

Model # 5648-16
Tow behind Lawn
Sweeper for grass
and leaves

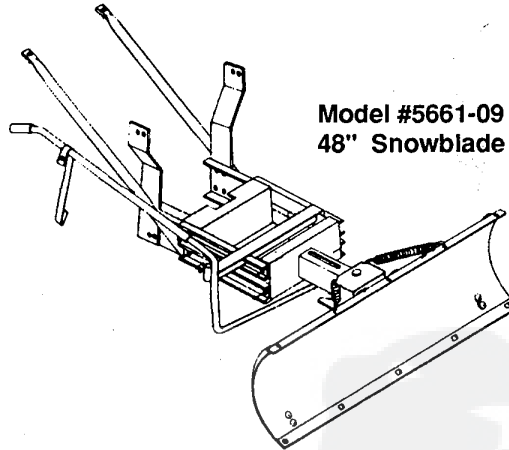

Model #5661-09
48" Snowblade

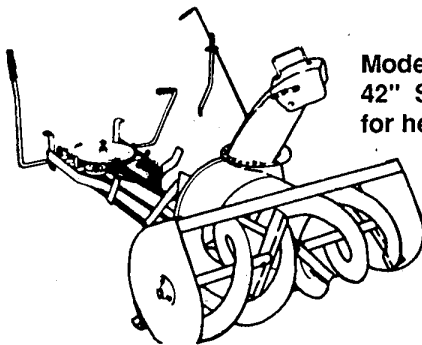

Model #5705-06
42" Snowthrower
for heavy snowfall

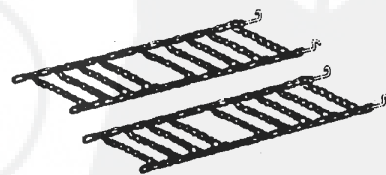

Model # 5585-00
Tire Chains - 20" x 8.0" tires
Model # 5706-00
Tire Chains - 20" x 10.0" tires

OTHER ACCESSORIES

Model	Description
5672-01	Wheel Weights - Front - 1 pr. w/mtg. hdw. - Fits 15" tires
5673-02	Wheel Weights - Rear - 1 pr. w/mtg. hdw. - Fits 18" & 20" tires
309070	40" High Lift Blade for Bagging or Side Discharge (Requires 2)
330277	40" Mulching Blade (Requires 2)
316608	43" High Lift Blade for Bagging or Side Discharge (Requires 2)
325762	43" Mulching Blade (Requires 2)