

Granja

MANUEL PIÈCES DE RECHANGE

Tracteur Tondeuse



Model F3560-320
Modèle G1305 SX

F3560-320

REPAIR PARTS

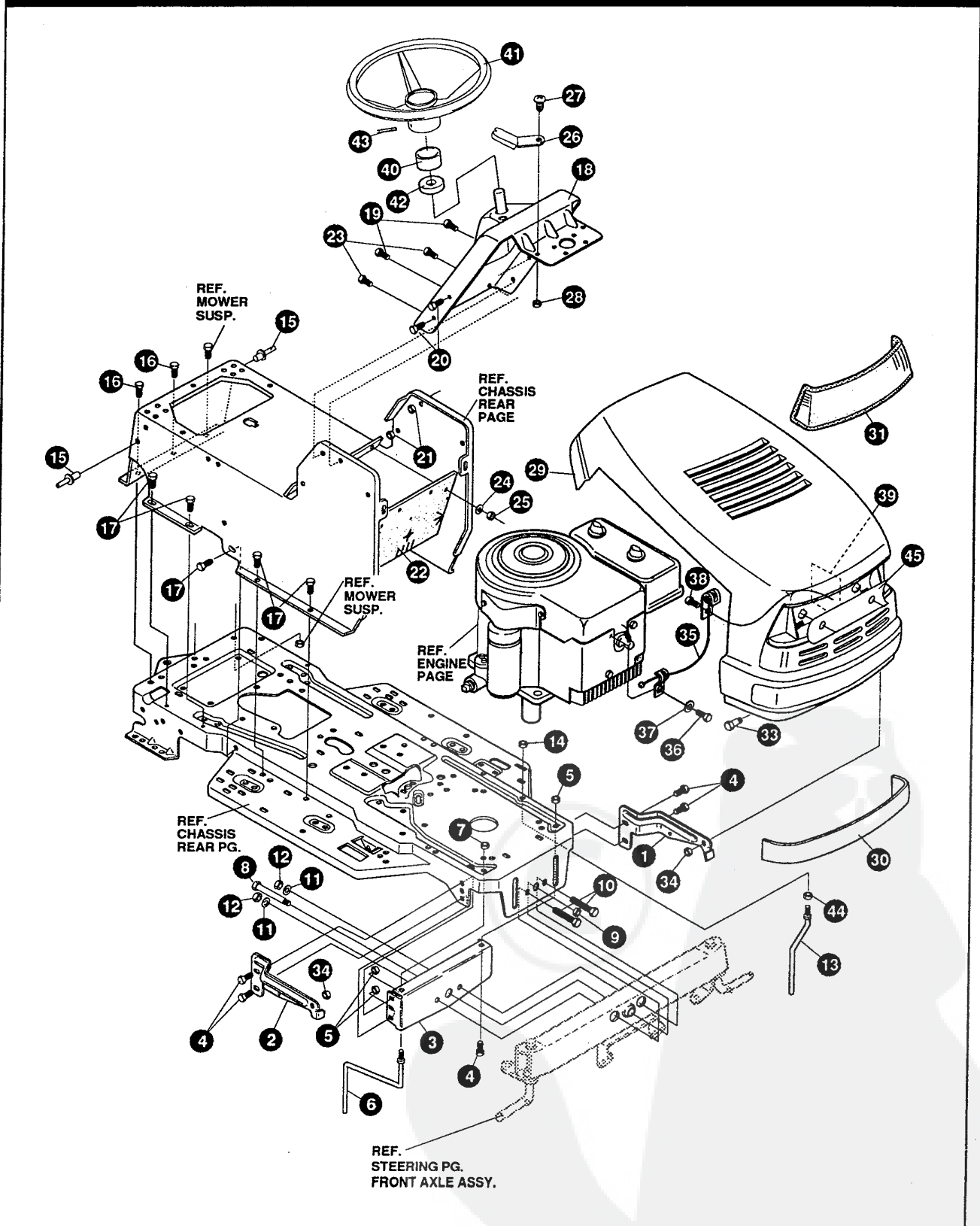

NOTE: ALWAYS USE ORIGINAL EQUIPMENT PARTS.
Use of service/replacement parts other than original equipment parts may void your warranty.

**ALL UNNUMBERED
ITEMS ARE INTERCHANGEABLE
WITH OPPOSITE SIDE**

325863 D

F3560-320

CHASSIS & HOOD ASSEMBLY

KEY#	PART#	DESCRIPTION	QTY
1	302857-853	BRACKET, GRILLE, LH, H-14	1
2	302856-853	BRACKET, GRILL, RH, H-14	1
3	313541-853	BRACKET, FRONT AXLE	1
4	56030	SCREW, 5/16-18 X .75 WDFLLK	5
5	55273	NUT, 5/16-18 WDFLLKLRG, WHIZ	5
6	300440	GUIDE, BELT, RIDER	1
7	1498	NUT, 5/16-18 REGHEXCTRLK	1
8	308207	BOLT, .625 X 2.18 HSSH, 1/2-13	1
9	309008	NUT, 1/2-13 HEXJAM CTRLK	1
10	180138	SCREW, 3/8-16 X 3.00 HHC	2
11	2483	WASHER, .39 ID X 1.25 D X .07 BELLVIL	2
12	1499	NUT, 3/8-16 REGHXCTRLK	2
13	300635	GUIDE, BELT SHORT, 15" WHEEL	1
14	124824	NUT, 5/16-18 HEXJAM	1
15	46763	RIVET, POP .187 DIA X .450 LONG	3
16	35497	SCREW, 5/16-18 X .50 WAHHTAP	2
17	995346	SCREW, 1/4-20 X .50 WAHHTAP	10
18	309447-860	DASH, STEEL, LF, SUSP	1
19	995346	SCREW, 1/4-20 X .50 WAHHTAP	2
20	44811	SCREW, 1/4-20 X .75 WAHHTAP	4
21	50352	NUT, 1/4-20 WDFLLK TOPLOCK	4
22	312306	BAFFLE, CONSOLE, SOUND EXPORT, LF	1
23	44811	SCREW, 1/4-20 X .75 WAHHTAP	2
24	120392	WASHER, FLAT .281 X .63 X .065	2
25	1502	NUT, 1/4-20 REGHEXCTRLK	2
26	313021-853	GUIDE, HOOD, SF & LF, H13, H14, H15	2
27	180020	SCREW, 1/4-20 X .75 HHC	2
28	51335	NUT, 1/4-20 WDFLWHIZ-LK	2
29	304026	HOOD, MEDIUM, H-14	1
30	322700	DECAL, TAPE H14, 8 MIL, VINYL	1
31	302670	LENS, HEADLAMP, HOOD	1
33	56676	BOLT, .375 X .580 HSSH, 5/16-18	2
34	1498	NUT, 5/16-18 REGHEXCTRLK	2
35	310749	LANYARD, HOOD, 9.16 LONG, H14	1
36	180020	SCREW, 1/4-20 X .75 HHC	1
37	120380	WASHER, REGSPTLK .263 X .49 X .07	1
38	49050	SCREW, 1/4-10 X .75 PHPNTAP	1
39	301452	FOIL, HEAT REFLECTOR	1
40	311465	COVER, STEERING SHAFT	1
41	330510	STEERING WHEEL	1
42	301413	SPACER, STEERING SHAFT	1
43	456378	PIN, SPRING .250 DIA X 2.00 LONG	1
44	271190	NUT, 3/8-16 HEXKEPS	1
45	308492	FOIL, LENS, HOOD REFLECTOR	1
	336552	PARTS MANUAL	1
	336568	OPERATOR'S MANUAL (FRENCH)	1
	327627	GRASS CATCHER MANUAL	1
	328195	AIR ASSIST MANUAL (ENGLISH)	1
	330272	AIR ASSIST MANUAL (FRENCH)	1
	330273	AIR ASSIST MANUAL (GERMAN)	1

F3560-320

REPAIR PARTS

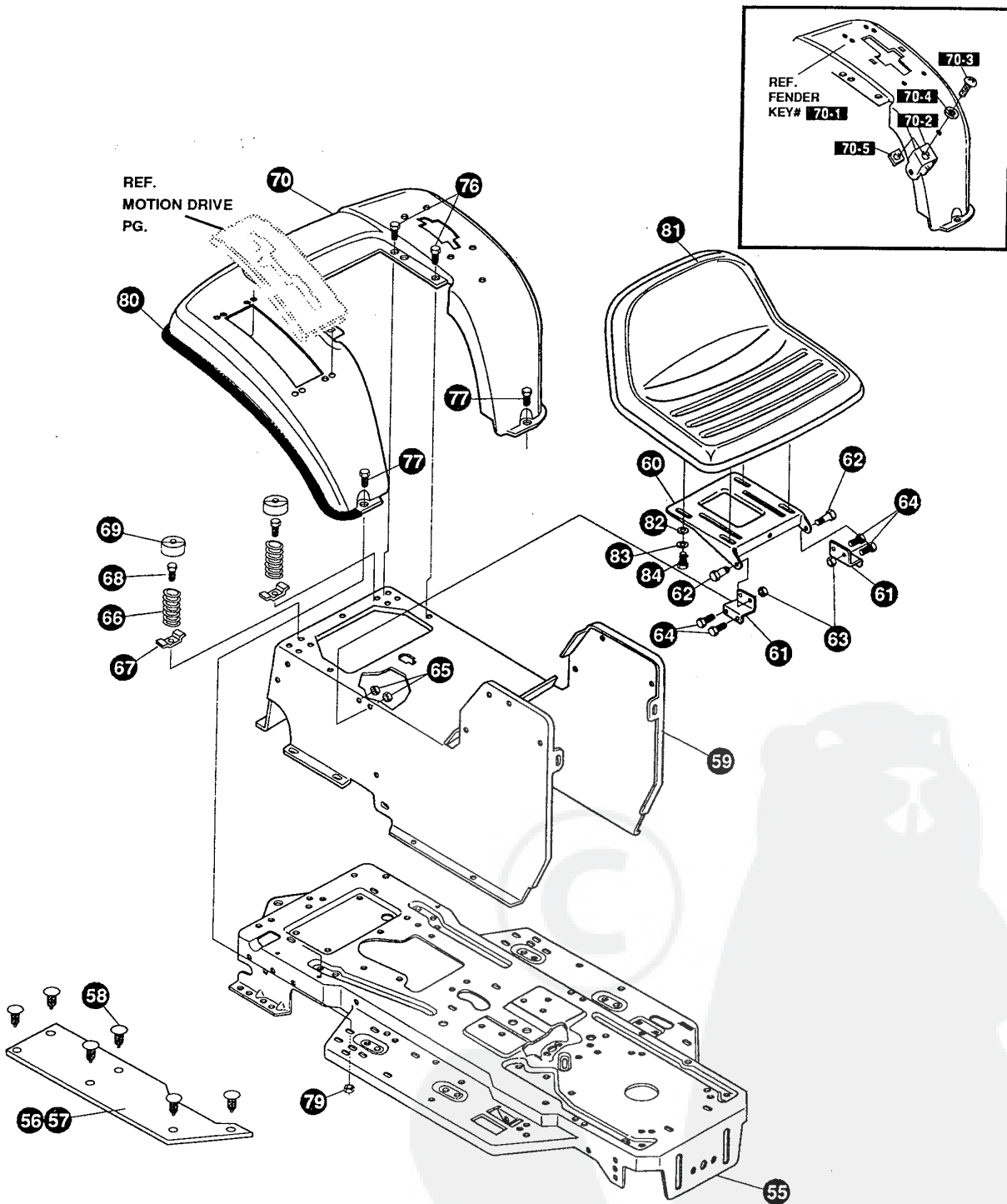

NOTE: ALWAYS USE ORIGINAL EQUIPMENT PARTS.
Use of service/replacement parts other than original equipment parts may void your warranty.

**ALL UNNUMBERED
ITEMS ARE INTERCHANGEABLE
WITH OPPOSITE SIDE**

325863 D

F3560-320

CHASSIS & HOOD ASSEMBLY

KEY#	PART#	DESCRIPTION	QTY
55	335697-860	FRAME, LF, MAIN, P920/F4360.....	1
56	310005	FOOT PAD, LH, 22.12 LG, F-5.....	1
57	310006	FOOT PAD, RH, 22.12 LG, F-5.....	1
58	309235	FASTENER, RATCHET, BLACK.....	12
59	308665-860	CONSOLE, H14-15, SOF.....	1
60	58367-860	PLATE, SEAT F5, SF, LF.....	1
61	310660-860	BRACKET, F-5, SEAT SUPPORT.....	2
62	20507	BOLT, .437 X .156 HSH, 5/16-18.....	2
63	1498	NUT, 5/16-18 REGHEXCTRLK.....	2
64	48901	SCREW, 5/16-18 X .63 WAHHC.....	4
65	1498	NUT, 5/16-18 REGHEXCTRLK.....	4
66	57153	SPRING, SEAT 2.63 LONG, 1.49 OD BLACK.....	2
67	1341	CLAMP, SPRING 1.17"ID.....	2
68	44811	SCREW, 1/4-20 X .75 WAHHTAP.....	2
69	56907	COVER, SEAT SPRING, 1.5 ID X 1.0 LONG.....	2
70	*	ASSEMBLY, FENDER, F5, LF, SOF, SUSP.....	1
70-1	332185	FENDER, F5, SUS, LF, SOF.....	1
70-2	9239	CLEVIS.....	1
70-3	439455	SCREW, 5/16-18 X .56PHPNMA.....	1
70-4	301551	WASHER, .344 ID X 1.50 D X .09.....	1
70-5	120373	NUT, 5/16-18 SQUARE.....	1
76	995346	SCREW, 1/4-20 X .50 WAHHTAP.....	4
77	126358	BOLT, 5/16-18 X 1.00 CARRLN.....	2
79	55273	NUT, 5/16-18 WDFLLKLRG WHIZ.....	2
80	55023	TRIM, STRIP, BLACK—SMALL, W/ADH.....	77.5"
81	304316	SEAT, MICHIGAN GEN, W/SW HOLE.....	1
82	120393	WASHER, FLAT .344 X .69 X .065.....	4
83	120638	WASHER, HVSPTLK .328 X .60 X .09.....	4
84	180077	SCREW, 5/16-18 X .75 HHC.....	4

* ORDER INDIVIDUAL PARTS - ASSEMBLY NOT AVAILABLE

F3560-320

REPAIR PARTS

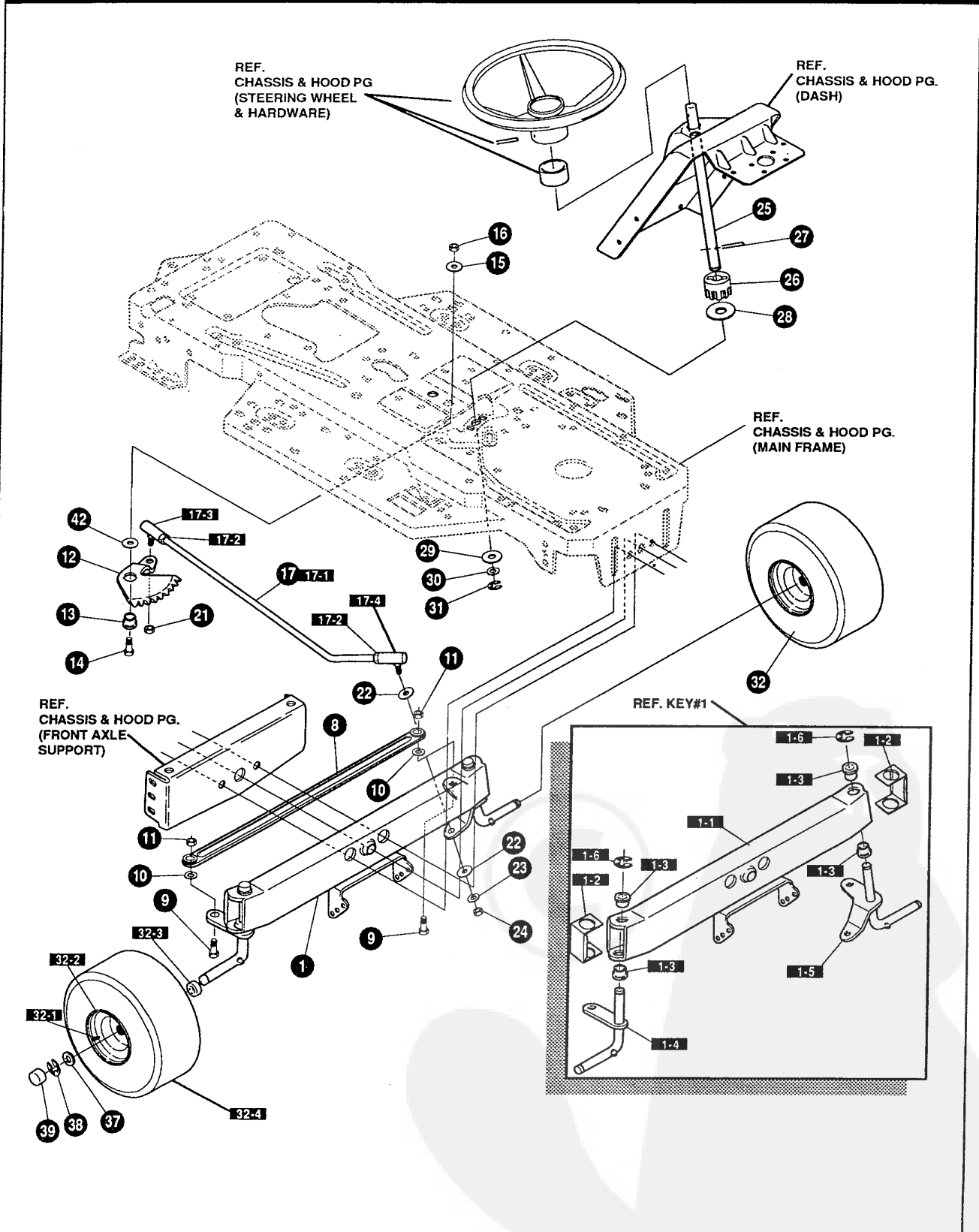

NOTE: ALWAYS USE ORIGINAL EQUIPMENT PARTS.
 Use of service/replacement parts other than original equipment parts may void your warranty.

ALL UNNUMBERED ITEMS ARE INTERCHANGEABLE WITH OPPOSITE SIDE

315136 J

F3560-320

STEERING ASSEMBLY

KEY#	PART#	DESCRIPTION	QTY
1	*	ASSEMBLY, AXLE FRONT, 4/WS, SUSP	1
1-1	310170	ASSEMBLY, FRONT AXLE, SUSPENDED	1
1-2	53373-853	AXLE COVER	2
1-3	52407	SPINDLE BEARING	4
1-4	302926	ASSEMBLY, SPINDLE, RH	1
1-5	315886	ASSEMBLY, SPINDLE, LH	1
1-6	36625	RING, RETEX .57 X .05 TRU 5133-75	2
8	304590	TIE ROD ASSEMBLY, 19.81 LONG W-SECTION	1
9	180128	SCREW, 3/8-16 X 1.75 HHC	2
10	120382	WASHER, REGSPTLK .393 X .68 X .10	2
11	1499	NUT, 3/8-16 REGHXCTRLK	2
12	58289	SECTOR, STEERING LF	1
13	52406	BEARING, FLANGE ECC .510 ID X .998 OD X .56	1
14	180177	SCREW, 1/2-13 X 1.50 HHC	1
15	22265	WASHER, FLAT .515 X 1.38 X .119	1
16	1500	NUT, 1/2-13 REGHXCTRLK	1
17	311100	KIT 300146 DRAGLINK	1
17-1	58291	STEERING LINK	1
17-2	124925	NUT, 3/8-24 REGHEXJAM	2
17-3	57158	BALL JOINT, 3/8 THD SHORT STUD	1
17-4	21275	BALL JOINT, 3/8 THD LONG STUD	1
21	46692	NUT, 3/8-24 WDFLHLK WHIZ	1
22	996416	WASHER, FLAT .391 X 1.00 X .125	2
23	120382	WASHER, REGSPTLK .393 X .68 X .10	1
24	120369	NUT, 3/8-24 REGHEX	1
25	58243	SHAFT, STEERING, LF, 2WS	1
26	58244	PINION, STEERING, LF	1
27	58274	PIN, DOWEL .2500 OD+1.75 LONG	1
28	301410	BEARING, FLANGE .752 ID X 1.061 OD X .24	1
29	301398	WASHER, FORMED 1.135 X 1.53 X .12	1
30	21682	WASHER, FLAT .765 X 1.25 X .042	1
31	36625	RING, RETEX .57 X .05 TRU 5133-75	1
32	*	TIRE & RIM, PU 15 X 6.0 X 6	2
32-1	24167	VALVE STEM	
32-2	39829	RIM, WHEEL	
32-3	314416	BEARING, FLANGE	
32-4	TIRE	REFER TO TIRE TREAD PAGE	
37	642	WASHER, FLAT .755 X 1.31 X .075	4
38	36625	RING, RETEX .57 X .05 TRU 5133-75	2
39	40394	HUB CAP, 1.500 ID X 7/8 LONG	2
42	49998	WASHER, FLAT .520 X 1.25 X .209	1

* ORDER INDIVIDUAL PARTS - ASSEMBLY NOT AVAILABLE

F3560-320

REPAIR PARTS

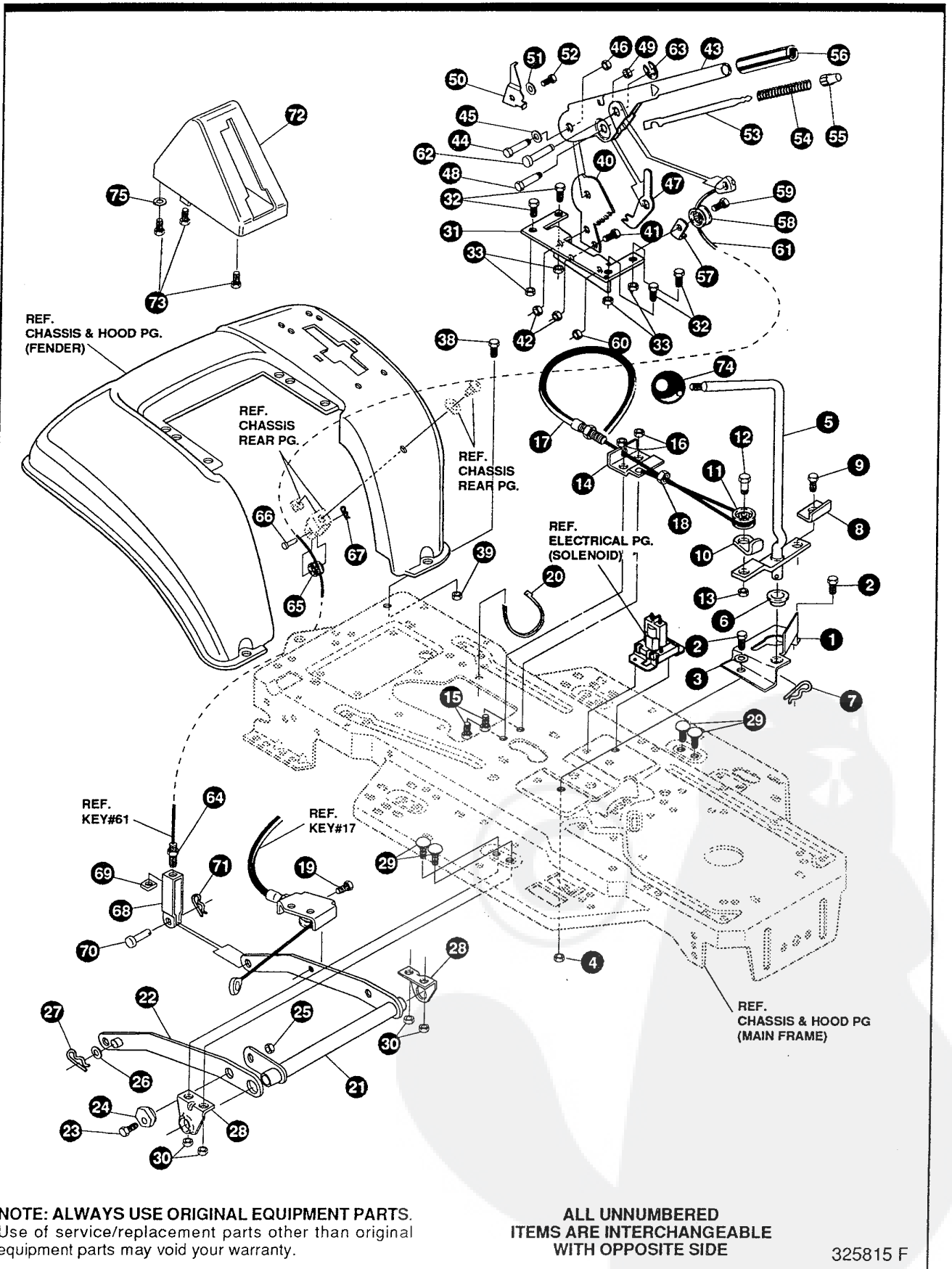

NOTE: ALWAYS USE ORIGINAL EQUIPMENT PARTS.
 Use of service/replacement parts other than original equipment parts may void your warranty.

**ALL UNNUMBERED
 ITEMS ARE INTERCHANGEABLE
 WITH OPPOSITE SIDE**

325815 F

F3560-320

MOWER SUSPENSION ASSEMBLY

KEY#	PART#	DESCRIPTION	QTY
1	320075-853	BRACKET, CLUTCH ENGAGE LEVER	1
2	180079	SCREW, 5/16-18 X 1.00 HHC	2
3	120393	WASHER, FLAT .344 X .69 X .065	2
4	1498	NUT, 5/16-18 REGHEXCTRLK	2
5	304791	ASSEMBLY, CLUTCH LEVER	1
6	50148	BEARING, FLANGE .503 ID X .63 OD X .50	1
7	8260	PIN, HAIR .091 DIA X 1.66 LONG	1
8	318341	BRACKET, SWITCH ENGAGE	1
9	35498	SCREW, 5/16-18 X .75 WAHTAP	1
10	1288	BRACKET, CABLE RETAINER	1
11	48306	PULLEY, METAL	1
12	58336	BOLT, .375 X .375 HSH, 1/4-20	1
13	1502	NUT, 1/4-20 REGHEXCTRLK	1
14	300698-853	BRACKET, FRAME CABLE	1
15	180020	SCREW, 1/4-20 X .75 HHC	2
16	1502	NUT, 1/4-20 REGHEXCTRLK	2
17	301503	ASSEMBLY, CABLE, BLADE ENGAGE	1
18	120613	NUT, 1/4-28 HJAM	1
19	35498	SCREW, 5/16-18 X .75 WAHTAP	1
20	57444	TIE, CABLE BLACK NYLON, 5.62 LONG	1
21	300158-853	LIFT ASSEMBLY, LH	1
22	300169-853	LIFT ASSEMBLY, RH	1
23	180079	SCREW, 5/16-18 X 1.00 HHC	1
24	58247	NUT, ADJUST	1
25	1498	NUT, 5/16-18 REGHEXCTRLK	1
26	417098	WASHER, FLAT .531 X 1.06 X .063	2
27	8260	PIN, HAIR .091 DIA X 1.66 LONG	2
28	58248-853	BRACKET, REAR HANG SUSPENSION	2
29	57072	BOLT, 5/16-18 X .63 CARRLN	4
30	1498	NUT, 5/16-18 REGHEXCTRLK	4
31	313926	BRACKET, HEIGHT/ADJUST SUPPORT	1
32	180077	SCREW, 5/16-18 X .75 HHC	4
33	1498	NUT, 5/16-18 REGHEXCTRLK	4
38	180077	SCREW, 5/16-18 X .75 HHC	1
39	1498	NUT, 5/16-18 REGHEXCTRLK	1
40	301238	QUADRANT, HEIGHT ADJUST	1
41	180077	SCREW, 5/16-18 X .75 HHC	2
42	1498	NUT, 5/16-18 REGHEXCTRLK	2
43	322292-853	HANDLE,LIFT SHORT(30" S.F.)	1
44	300171	BOLT, .500 X .270 HSH, 5/16-18	1
45	996418	WASHER, FLAT .506 X .75 X .024	1
46	44108	NUT, 5/16-18 HWDFLCTRLK	1
47	301239	PAWL, SQUARE	1
48	300171	BOLT, .500 X .270 HSH, 5/16-18	1
49	44108	NUT, 5/16-18 HWDFLCTRLK	1
50	9435	POINTER, HEIGHT ADJUST	1
51	138479	WASHER, EXLK .195 X .41 X .03	1
52	35287	SCREW, #8-32 X .38 HHWATAP	1
53	303027	ROD, ACTUATOR-SHORT	1
54	58326	SPRING, HEIGHT ADJUST	1
55	58325	KNOB, HEIGHT ADJUST, PUSH BUTTON	1
56	58329	GRIP, .750 OD, W/ HOLE BLACK	1
57	9149	BRACKET, CABLE RETAINER	1
58	48306	PULLEY, METAL	1
59	58336	BOLT, .375 X .375 HSH, 1/4-20	1
60	1502	NUT, 1/4-20 REGHEXCTRLK	1
61	314177	CABLE, LIFT, 22.92, F-5, 20 X 8-8	1
62	300310	PIN, CLEVIS .310 DIA+ .475 LONG	1
63	300311	RING, RET E .31 X .25 TRU 5133-31	1
64	120375	NUT, 1/4-20 REGHEX	1
65	48306	PULLEY, METAL	1
66	300317	PIN, CLEVIS .375 DIA X .81 LONG	1
67	8260	PIN, HAIR .091 DIA X 1.66 LONG	1
68	9405	CLEVIS, LIFT CABLE	1
69	120372	NUT, 1/4-20 REGSQ	1
70	39522	PIN, CLEVIS .312 X .812	1
71	121222	PIN, COTTER .090 DIA X .75 LONG	1
72	333903	LIFT COVER, F5, LF, SF, BLACK	1
73	300340	SCREW, #10 X .75 HHPLAST, BLACK	3
74	55514	KNOB, ROUND 1.50 DIA, BLACK	1
75	120392	WASHER, FLAT .281 X .63 X .065	1

F3560-320

REPAIR PARTS

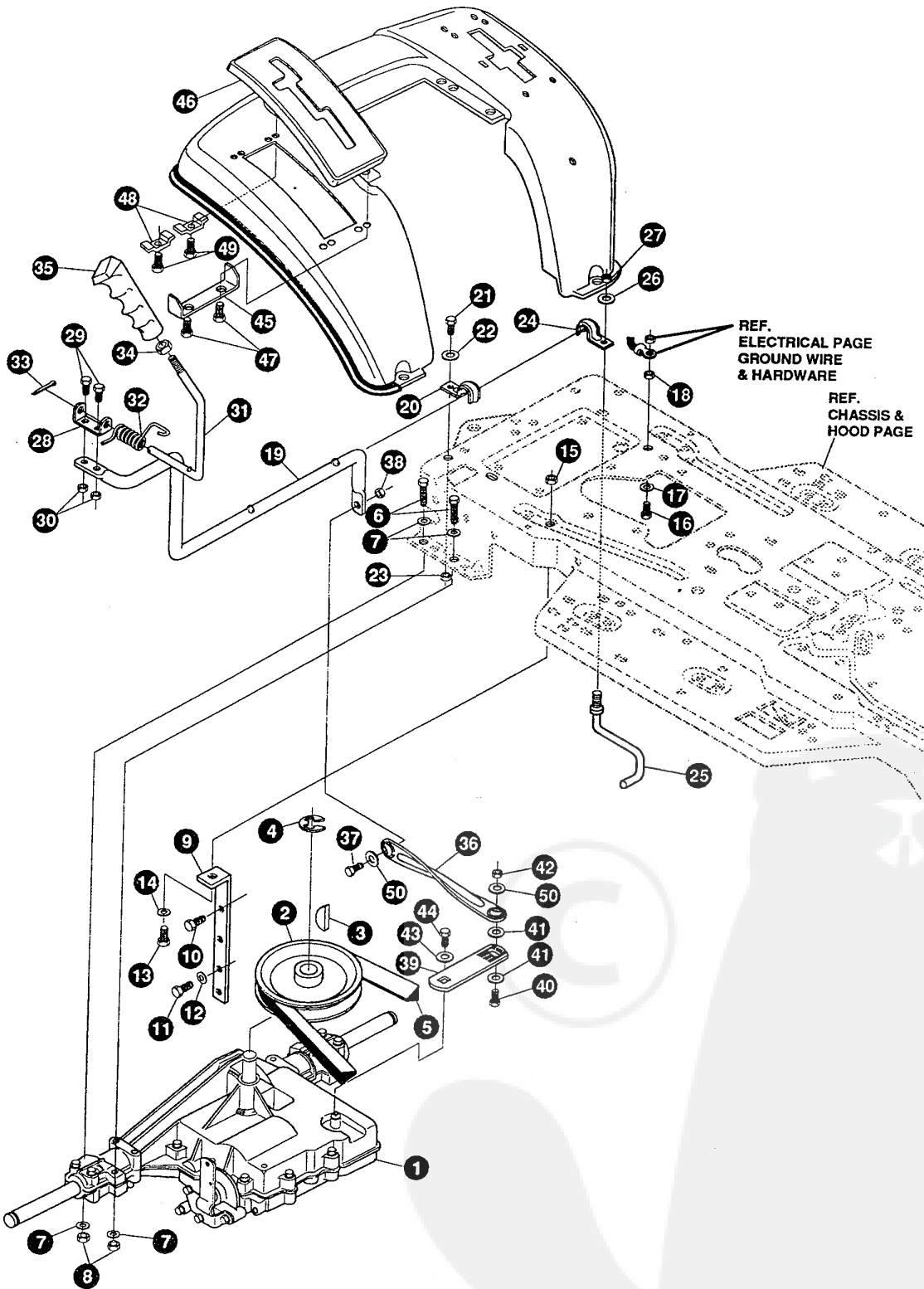

REF. ELECTRICAL PAGE
GROUND WIRE
& HARDWARE

REF. CHASSIS &
HOOD PAGE

NOTE: ALWAYS USE ORIGINAL EQUIPMENT PARTS.
Use of service/replacement parts other than original equipment parts may void your warranty.

**ALL UNNUMBERED
ITEMS ARE INTERCHANGEABLE
WITH OPPOSITE SIDE**

327669 E

F3560-320

MOTION DRIVE ASSEMBLY

KEY#	PART#	DESCRIPTION	QTY
1	^	TRANSAXLE, 930-017A, 6SP, 2WS, LF	1
2	302745	PULLEY, 6.6 OD, V4L, T/A	1
3	50795	KEY, HI-PRO 606 .75 DIA X .187 WD	1
4	22053	RING, RETEX .58 X .035 TRU 5100-62	1
5	314120	BELT, V 4L, 87.25, 4WS, LF	1
6	180091	SCREW, 5/16-18 X 2.50 HHC	4
7	120393	WASHER, FLAT .344 X .69 X .065	8
8	1498	NUT, 5/16-18 REGHEXCTRLK	4
9	323739	BRACKET, STABILIZER, BLACK	1
10	50947	SCREW, 3/8-16 X 1.25 WAHHTAP	1
11	35498	SCREW, 5/16-18 X .75 WAHHTAP	2
12	120638	WASHER, HVSPTLK .328 X .60 X .09	2
13	180079	SCREW, 5/16-18 X 1.00 HHC	1
14	120393	WASHER, FLAT .344 X .69 X .065	1
15	1498	NUT, 5/16-18 REGHEXCTRLK	1
16	180077	SCREW, 5/16-18 X .75 HHC	1
17	138538	WASHER, REGINTLK .320 X .61 X .03	1
18	1498	NUT, 5/16-18 REGHEXCTRLK	1
19	319111	LEVER, SHIFT-LOWER, P930/4360, LF	1
20	310347-853	CLIP- SHIFT LEVER, .625 ROD	1
21	180077	SCREW, 5/16-18 X .75 HHC	1
22	996416	WASHER, FLAT .391 X 1.00 X .125	1
23	1498	NUT, 5/16-18 REGHEXCTRLK	1
24	310347-853	CLIP- SHIFT LEVER, .625 ROD	1
25	57259	GUIDE, BELT, 5/16-18 THD	1
26	996416	WASHER, FLAT .391 X 1.00 X .125	1
27	1498	NUT, 5/16-18 REGHEXCTRLK	1
28	310356	BRACKET, PIVOT, SHIFT LEVER	1
29	180020	SCREW, 1/4-20 X .75 HHC	2
30	1502	NUT, 1/4-20 REGHEXCTRLK	2
31	324798	LEVER, SHIFT, UPPER, SOF, 1/2-13	1
32	310265	SPRING, TORSION, .56 X .95 X .095	1
33	137185	PIN, COTTER .125 DIA X 1.00 LONG	1
34	120238	NUT, 1/2-13 HEXJAM	1
35	306690	HANDLE, 1/2-13 MOLDED, BLACK	1
36	314965	LINK, TIE ROD, SHIFT, P930-6 SHORT	1
37	180124	SCREW, 3/8-16 X 1.25 HHC	1
38	1499	NUT, 3/8-16 REGHXCTRLK	1
39	309637	BRACKET, SHIFT, 5SP, SF	1
40	180124	SCREW, 3/8-16 X 1.25 HHC	1
41	120394	WASHER, FLAT .406 X .81 X .065	2
42	1499	NUT, 3/8-16 REGHXCTRLK	1
43	57157	WASHER, .750 X .250, SP-TRANSAXLE	1
44	56255	SCREW, 1/4-28 X .75 NYLHHC	1
45	311257-853	BRACKET, COVER, F5, FENDER SHIFT	1
46	311209	COVER, PLASTIC, LF, P930/F4360-6	1
47	311331	SCREW, 1/4-15 X .44/.53 HILOHWA	2
48	1341	CLAMP, SPRING 1.17" ID	2
49	311331	SCREW, 1/4-15 X .44/.53 HILOHWA	2
50	120394	WASHER, FLAT .406 X .81 X .065	2

^ CONTACT YOUR NEAREST TRANSAXLE DEALER FOR PARTS & SERVICE

F3560-320

REPAIR PARTS

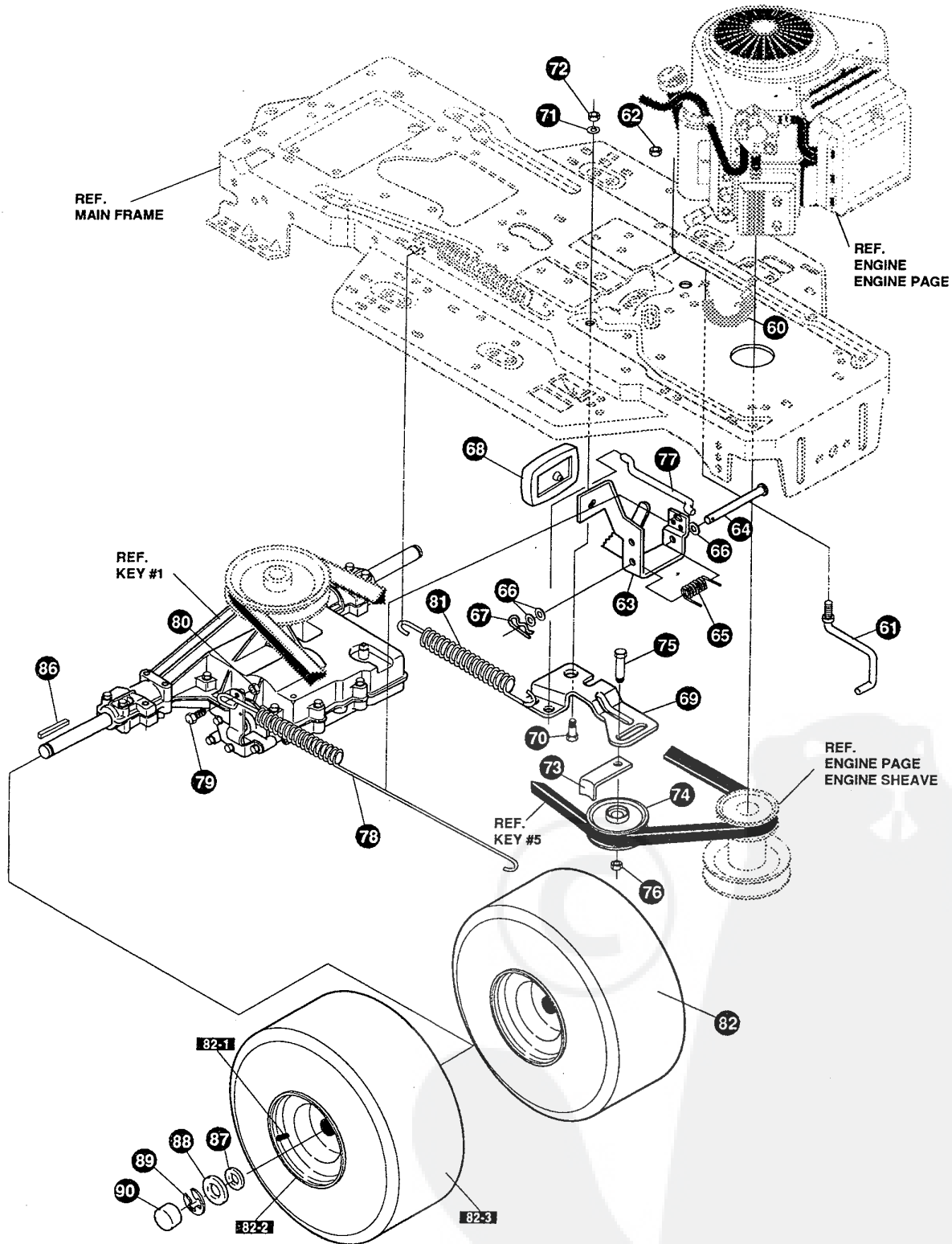

NOTE: ALWAYS USE ORIGINAL EQUIPMENT PARTS.
Use of service/replacement parts other than original equipment parts may void your warranty.

**ALL UNNUMBERED
ITEMS ARE INTERCHANGEABLE
WITH OPPOSITE SIDE**

327669 E

F3560-320**MOTION DRIVE ASSEMBLY**

KEY#	PART#	DESCRIPTION	QTY
60	321514	SPRING, DRAG LINK BIAS	1
61	304016	GUIDE, BELT, RH	1
62	1498	NUT, 5/16-18 REGHEXCTRLK	1
63	325942	PEDAL ASSEMBLY, BRAKE/CLUTCH, LF	1
64	319675	PIN, CLEVIS .500 D X 4.53 LONG	1
65	57847	SPRING, BRAKE PEDAL	1
66	2968	WASHER, FLAT .504 X .75 X .059	3
67	56180	PIN, HAIR .091 DIA X 1.62 LONG	1
68	48160	PAD, CLUTCH BRAKE, W/PRINTING	1
69	320381	ARM, IDLER, TRACTION, SOG, LF	1
70	329989	BOLT, .625 X .135 HSH, 5/16-18	1
71	45602	WASHER, FLAT .333 X .87 X .119	1
72	1498	NUT, 5/16-18 REGHEXCTRLK	1
73	39659	RETAINER, BELT	1
74	35374	PULLEY, IDLER V4L, 3.06 X .62	1
75	45892	BOLT, 3/8-16 X 1.50 CARRSN	1
76	1499	NUT, 3/8-16 REGHXCTRLK	1
77	57204	ROD, CLUTCH 3.92"	1
78	325937	SPRING, BRAKE, 28.80 930, 4360	1
79	326131	BOLT, .495 X .31 HSH, 5/16-18	1
80	1498	NUT, 5/16-18 REGHEXCTRLK	1
81	330505	SPRING, CLUTCH, .113 X .750 X 8.75	1
82	*	TIRE & RIM, 20 X 8.00-8	2
82-1	24167	VALVE STEM	
82-2	57165	RIM, WHEEL	
82-3	TIRE	REFER TO TIRE TREAD PAGE	
86	52928	KEY, SQUARE .187 SQUARE X 2.25 LONG	2
87	642	WASHER, FLAT .755 X 1.31 X .075	4
88	42815	WASHER, FLAT .755 X 1.53 X .07	2
89	36625	RING, RETEX .57 X .05 TRU 5133-75	2
90	40394	HUB CAP, 1.500ID X 7/8 LONG	2

* ORDER INDIVIDUAL PARTS - ASSEMBLY NOT AVAILABLE

F3560-320

REPAIR PARTS

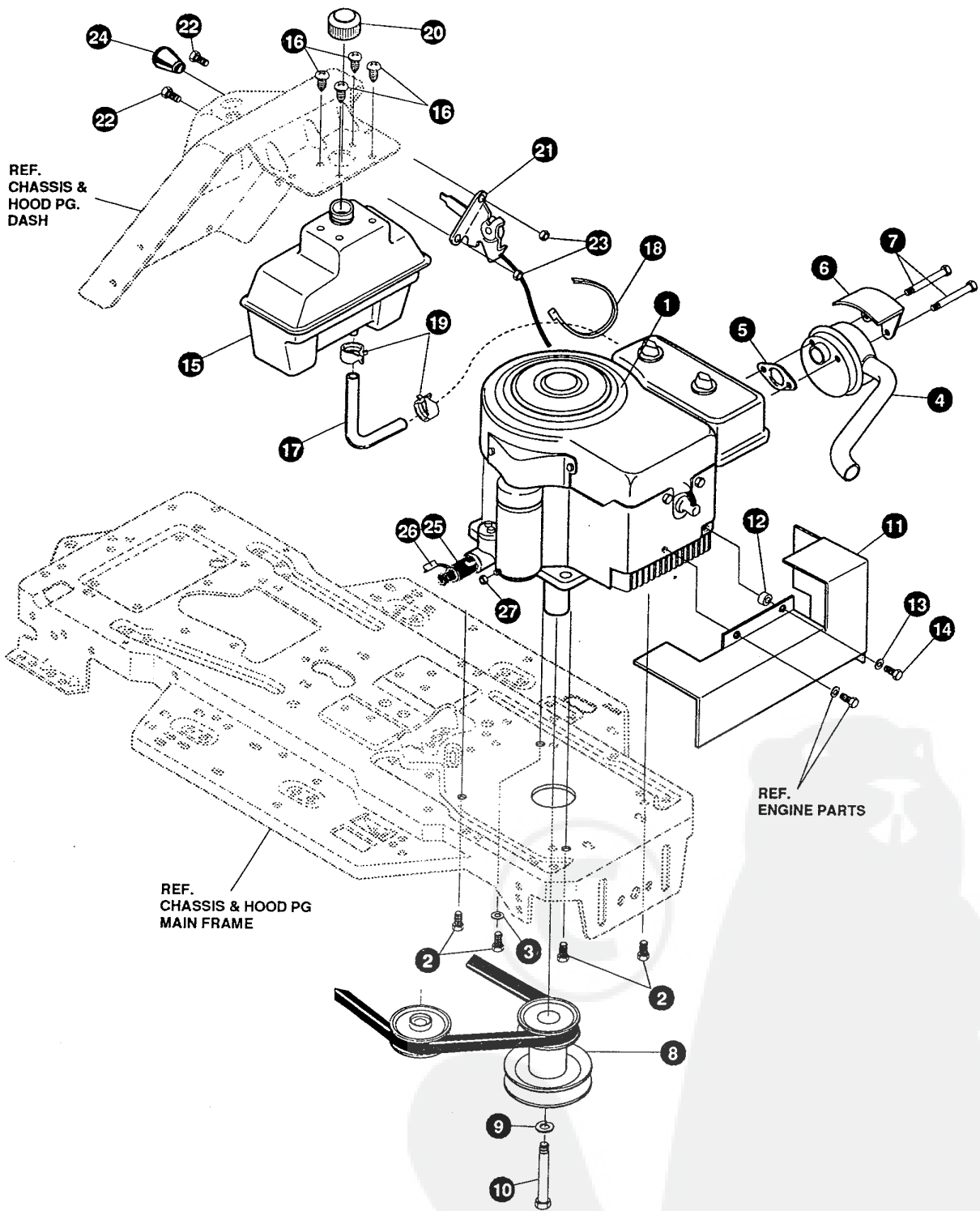

NOTE: ALWAYS USE ORIGINAL EQUIPMENT PARTS.
Use of service/replacement parts other than original equipment parts may void your warranty.

**ALL UNNUMBERED
ITEMS ARE INTERCHANGEABLE
WITH OPPOSITE SIDE**

333107 A

F3560-320

ENGINE & CONTROL ASSEMBLY

KEY#	PART#	DESCRIPTION	QTY
1	*	ENGINE, 12-12.5HP, B&S, IC, DUAL.....	1
2	50947	SCREW, 3/8-16 X 1.25 WAHTAP	4
3	138489	WASHER, EXLK .384 X .69 X .04	1
4	305367	MUFFLER-LO TONE, NELSON, EXPORT	1
5	46708	GASKET, MUFFLER	1
6	54767	SHIELD, HEAT, FOR ROUND MUFFLER.....	1
7	54980	SCREW, 5/16-18 X 3.50 HHC	2
8	328028	PULLEY, ENGINE 3.0D X 4.0 LONG X 5.0D	1
9	120383	WASHER, REGSPTLK .459 X .78 X .12	1
10	433146	SCREW, 7/16-20 X 4.25 HHC, BLACK	1
11	308543-853	HEAT SHIELD ASSEMBLY, 11 & 12HP	1
12	41462	SPACER, SLEEVE .328 X .75 X .312	1
13	120380	WASHER, REGSPTLK .263 X .49 X .07	1
14	180022	SCREW, 1/4-20 X 1.00 HHC	1
15	314989	TANK, FUEL 1 GALLON, CLEAR	1
16	49050	SCREW, 1/4-10 X .75 PHPNTAP	4
17	50118	TUBING, .25 X .50 X BULK GAS LINE	13.5"
18	57444	TIE, CABLE BLACK NYLON, 5.62 LONG	1
19	47345	CLAMP, HOSE SCREW TYPE	2
20	46704	CAP, GAS 1-1/2-7 THD, BLACK	1
21	321273	CONTROL, THROTTLE 12-12.5HP, LF	1
22	320553	SCREW, 10-24 X .63 PHPNMA	2
23	308459	NUT, #10-24 HXHDNYLK	2
24	50607	KNOB, ROUND THROTTLE, BLACK	1
25	325547	OIL DRAIN VALVE ASSEMBLY	1
26	327422	CAP, OIL DRAIN VALVE ASSEMBLY, YELLOW	1
27	124818	NUT, 1/4-20 REGHXJAM	1

* SEE ENGINE MANUAL

F3560-320

REPAIR PARTS

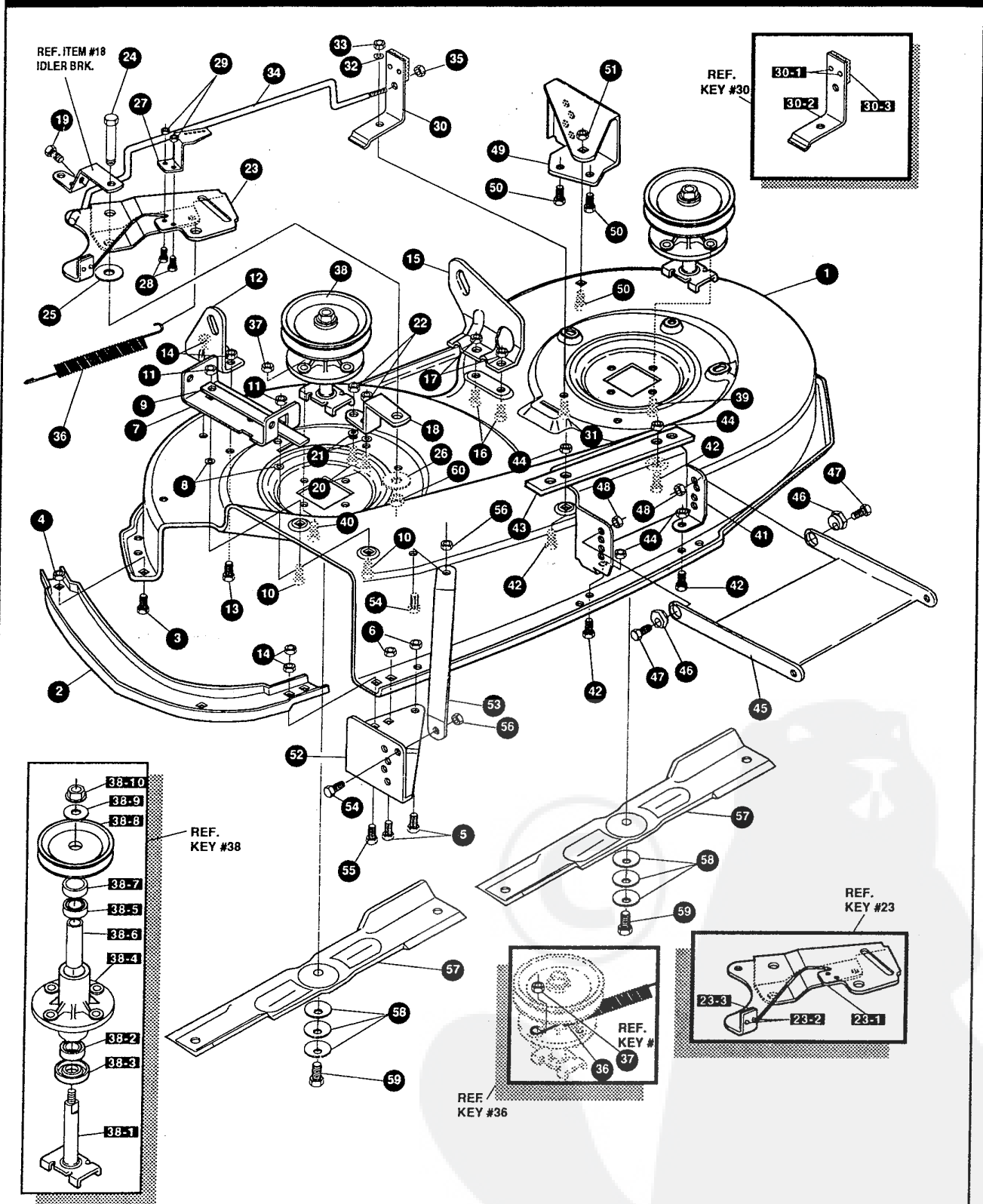

NOTE: ALWAYS USE ORIGINAL EQUIPMENT PARTS.
Use of service/replacement parts other than original equipment parts may void your warranty.

ALL UNNUMBERED ITEMS ARE INTERCHANGEABLE WITH OPPOSITE SIDE

331147 D

F3560-320

PRE-PAINTED DECK ASSEMBLY

KEY#	PART#	DESCRIPTION	QTY
1	325103	40" DECK KIT	1
2	326480	TOE GUARD - MULCHER	1
3	180077	SCREW, 5/16-18 X .75 HHC	1
4	1498	NUT, 5/16-18 REGHEXCTRLK	1
5	180077	SCREW, 5/16-18 X .75 HHC	1
6	1498	NUT, 5/16-18 REGHEXCTRLK	2
7	317017	BRACKET CHUTE MOUNT	1
8	120393	WASHER, FLAT .344 X .69 X .065	2
9	322320	LEVER ASSEMBLY (SHORT)	1
9-1	58319	PIN	1
9-2	322319	LEVER CHUTE LATCH (SHORT)	1
10	180077	SCREW, 5/16-18 X .75 HHC	2
11	1498	NUT, 5/16-18 REGHEXCTRLK	2
12	313929	BRACKET, RH, LIFT REAR	1
13	180077	SCREW, 5/16-18 X .75 HHC	2
14	1498	NUT, 5/16-18 REGHEXCTRLK	2
15	310667	BRACKET, LH, LIFT REAR	1
16	180077	SCREW, 5/16-18 X .75 HHC	2
17	1498	NUT, 5/16-18 REGHEXCTRLK	2
18	326893	BRACE, IDLER SUPPORT, 40", 43"	1
19	308231	SCREW, 1/4-20 X 1.25 HHWATAP	1
20	180077	SCREW, 5/16-18 X .75 HHC	2
21	120393	WASHER, FLAT .344 X .69 X .065	2
22	44108	NUT, 5/16-18 HWDFLCTRLK	2
23	320576	IDLER ARM ASSEMBLY	1
23-1	322116	ARM IDLER 40/43" DECK	1
23-2	41601	RIVET, OVSET .187 DIA X .50 LONG	2
23-3	306973	BRAKE PAD - HARD-NF343 (X-31)	1
24	304420	BOLT, .500 X 2.15 HSSH	1
25	996307	WASHER, FLAT .391 X 1.00 X .209	1
26	996416	WASHER, FLAT .391 X 1.00 X .125	2
27	326249	BRACKET, EXTENSION IDLER	1
28	180077	SCREW, 5/16-18 X .75 HHC	2
29	1498	NUT, 5/16-18 REGHEXCTRLK	2
30	321828	BLADE BRAKE ASSEMBLY	1
30-1	135624	RIVET, TRSET .185 DIA X .41 LONG	2
30-2	304119	BRAKE ARM	1
30-3	306973	BRAKE PAD - HARD-NF343 (X-31)	1
31	180077	SCREW, 5/16-18 X .75 HHC	1
32	120393	WASHER, FLAT .344 X .69 X .065	1
33	1498	NUT, 5/16-18 REGHEXCTRLK	1
34	315396	ROD, BRAKE, 40" DECK	1
35	1502	NUT, 1/4-20 REGHEXCTRLK	1
36	35410	SPRING, .071 X .62 X 4.37	1
37	1498	NUT, 5/16-18 REGHEXCTRLK	1
38	56424	QUILL ASSEMBLY, 36/39/40/43	2
38-1	56425	SHAFT/SADDLE 36"	1
38-2	49562	BEARING, BALL 6203-2AA-C3 ARMORED	1
30-3	50616	DUST SHIELD	1
30-4	55547	QUILL CASTING (1046)	1
30-5	49562	BEARING, BALL 6203-2AA-C3 ARMORED	1
30-6	50818	SPACER, SLEEVE .669 X .88 X 3.797	1
30-7	51449	SPACER, SLEEVE .672 X .93 X .438	1
30-8	313898	PULLEY ASSY	1
38-9	56365	WASHER, SPECIAL QUILL	1
30-10	1282	NUT, 7/16-20 WDFLLK	1
39	35498	SCREW, 5/16-18X .75 WAHHTAP	7
40	300345	SCREW, 5/16-18 X 1.38 WAHHTAP	1
41	318445	BRACKET, 40", LF, FRONT DECK	1
42	180077	SCREW, 5/16-18 X .75 HHC	4
43	328155	PLATE-MOUNTING	1
44	1498	NUT, 5/16-18 REGHEXCTRLK	4
45	58305	BRACKET, LINK, DECK FRONT	1
46	58247	NUT, ADJUST	2
47	180079	SCREW, 5/16-18 X 1.00 HHC	2
48	1498	NUT, 5/16-18 REGHEXCTRLK	2
49	317041	BRACKET, GAGE WHEEL, LH	1
50	180077	SCREW, 5/16-18 X .75 HHC	3
51	1498	NUT, 5/16-18 REGHEXCTRLK	3
52	322464	BRACKET, GAGE WHEEL, RH, FRONT	1
53	314282	BRACKET, STABILIZER	1
54	180077	SCREW, 5/16-18 X .75 HHC	1
55	12685	SCREW, 5/16-18 X 1.5 OHHCFT	1
56	1498	NUT, 5/16-18 REGHEXCTRLK	1
57	313316	BLADE, 40", STD-LIFT, 20.32	2
58	2483	WASHER, .39 ID X 1.25 D X .07 BELLVIL	6
59	39573	SCREW, 3/8-24 X 1.00 NYLHHC	2
60	45171	NUT, 3/8-16 HWDFL WHIZ-LOCK	1

F3560-320

REPAIR PARTS

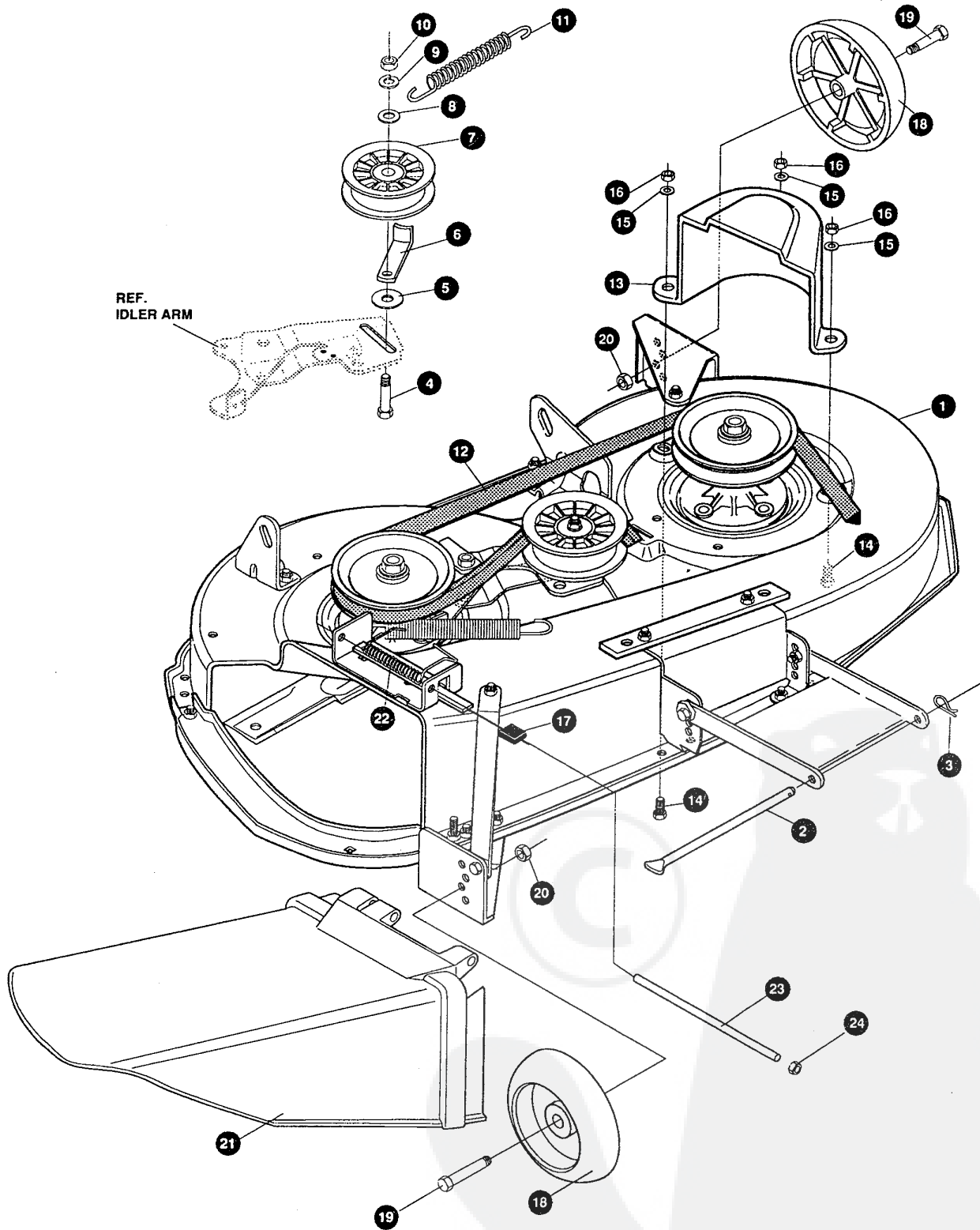

NOTE: ALWAYS USE ORIGINAL EQUIPMENT PARTS.
Use of service/replacement parts other than original equipment parts may void your warranty.

**ALL UNNUMBERED
ITEMS ARE INTERCHANGEABLE
WITH OPPOSITE SIDE**

331145 B

F3560-320**FINAL DECK ASSEMBLY**

KEY#	PART#	DESCRIPTION	QTY
1	329035	ASSEMBLY, 40"DECK, FOR AIR ASSIST	1
2	58306	ROD, DECK HITCH	1
3	8260	PIN, HAIR .091 DIA X 1.66 LONG	1
4	57325	BOLT, 3/8-16 X 2.00 CARRSN	1
5	25210	WASHER, FLAT .386 X 1.25 X .09	1
6	1346	RETAINER, BELT	1
7	310326	PULLEY, IDLER BFF 4.00 WIDE FL	1
8	996307	WASHER, FLAT .391 X 1.00 X .209	1
9	120382	WASHER, REGSPTLK .393 X .68 X .10	1
10	120377	NUT, 3/8-16 REGHX	1
11	300473	SPRING, TENSION 7.52 LONG+17LB/IN	1
12	319005	BELT, V 5L, 81.00, DECK 40", LF	1
13	328257	GUARD, BELT, LH, PLASTIC	1
14	180077	SCREW, 5/16-18 X .75 HHC	3
15	120393	WASHER, FLAT .344 X .69 X .065	3
16	1498	NUT, 5/16-18 REGHEXCTRLK	3
17	42348	GRIP-LEVER, GRASS COLLECTOR	1
18	302611	GAUGE WHEEL, EURO 6.00 OD X 1.38 WD	2
19	23763	BOLT, .500 X 1.390 HSH, 3/8-16	2
20	1499	NUT, 3/8-16 REGHXCTRLK	2
21	304422	CHUTE DEFLECTOR, 40", 42" & 43"	1
22	314975	SPRING, TORSION, CHUTE DEFLECTOR	1
23	304424	ROD, PIVOT DECK .312 D X 7.25	1
24	3535	NUT, PUSH ON CAP .312 OD	1

F3560-320

REPAIR PARTS

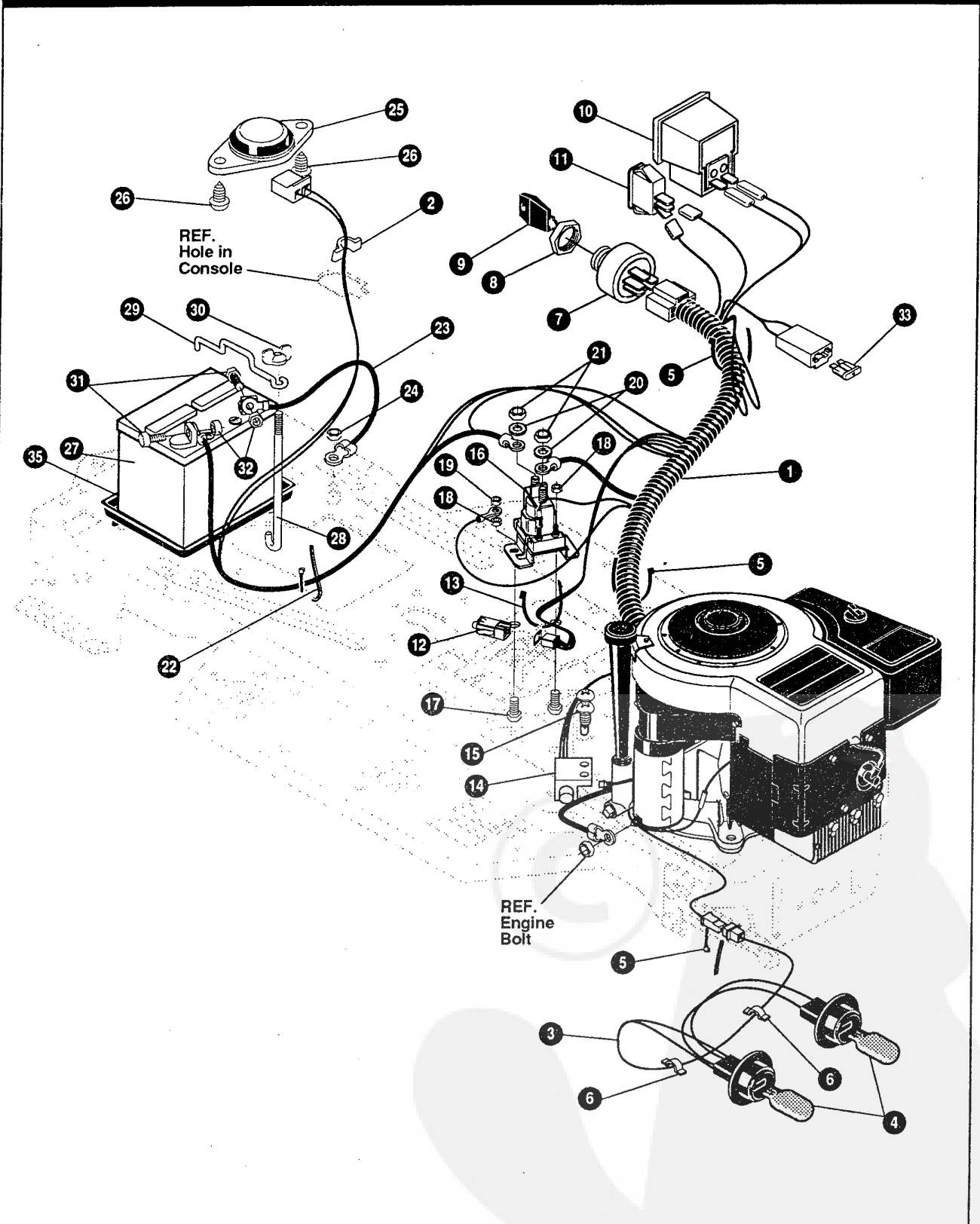

NOTE: ALWAYS USE ORIGINAL EQUIPMENT PARTS.
 Use of service/replacement parts other than original equipment parts may void your warranty.

ALL UNNUMBERED ITEMS ARE INTERCHANGEABLE WITH OPPOSITE SIDE

325502 D

F3560-320

ELECTRICAL ASSEMBLY

KEY#	PART#	DESCRIPTION	QTY
1	320065	HARNES, 12-12.5HP, B&S, H14, WRAP, LF	1
2	41482	PRESS CLIP, 1.380 LONG .255 ID	1
3	303064	ASSEMBLY, LIGHT WIRE-1/4 TURN	1
4	52572	BULB, HEADLAMP	2
5	57444	TIE, CABLE BLACK NYLON, 5.62 LONG	3
6	41482	PRESS CLIP, 1.380 LONG .255 ID	2
7	327355	SWITCH-IGNITION (AFTER FIRE) 3 POSITION	1
8	327352	NUT, 5/8-8 ACME DELTA FOR BOOT	1
9	327350	KEY, IGNITION	2
10	300133	AMMETER	1
11	300334	LIGHT SWITCH, ON/OFF, PANEL MOUNT	1
12	320082	SWITCH, DOUBLE POLE, NO/NC GRAY	1
13	57444	TIE, CABLE BLACK NYLON, 5.62 LONG	1
14	57476	SWITCH, SCREW MOUNT, DP, NC, NO BLACK	1
15	57220	SCREW, #12 X .50 PHPNHTAP, BLACK	2
16	53716	SOLENOID	1
17	187745	SCREW, 1/4-20 X .75 HXSEMMA	2
18	1502	NUT, 1/4-20 REGHEXCTRLK	2
19	271172	NUT, 1/4-20 REGHEXKEPS	1
20	138485	WASHER, EXLK .320 X .61 X .03	2
21	120368	NUT, 5/16-24 REGHEX	2
22	57444	TIE, CABLE BLACK NYLON, 5.62 LONG	1
23	55511	WIRE, GROUND, 12.5"	1
24	271184	NUT, 5/16-18 HEXKEPS	1
25	57547	SWITCH, SEAT	1
26	160505	SCREW, 1/4-20 X .38 PHPNHMA	2
27	92693	BATTERY, 12V	1
28	57551	ROD, BATTERY	1
29	57552	ROD, BATTERY, TOP	1
30	325232	NUT, WING 1/4-20 NYLON	1
31	180020	SCREW, 1/4-20X .75 HHC	2
32	271172	NUT, 1/4-20 REGHEXKEPS	2
35	91895	TRAY - BATTERY	1

SCHEMATIC DRAWING

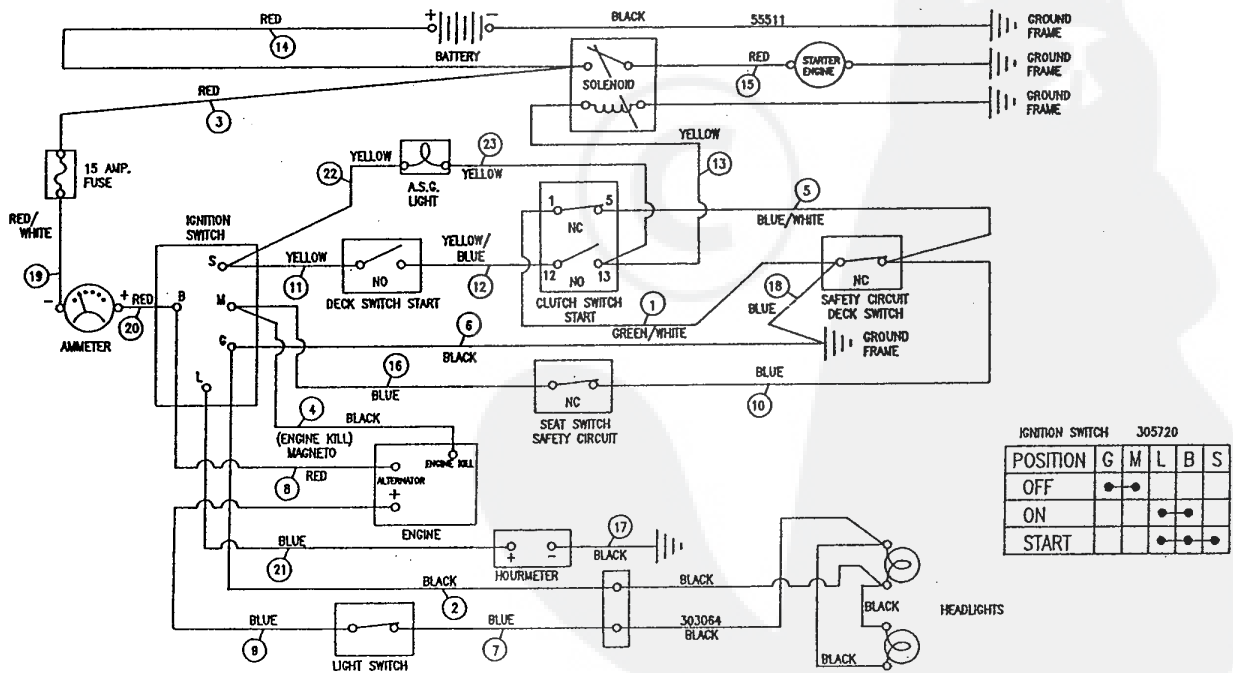

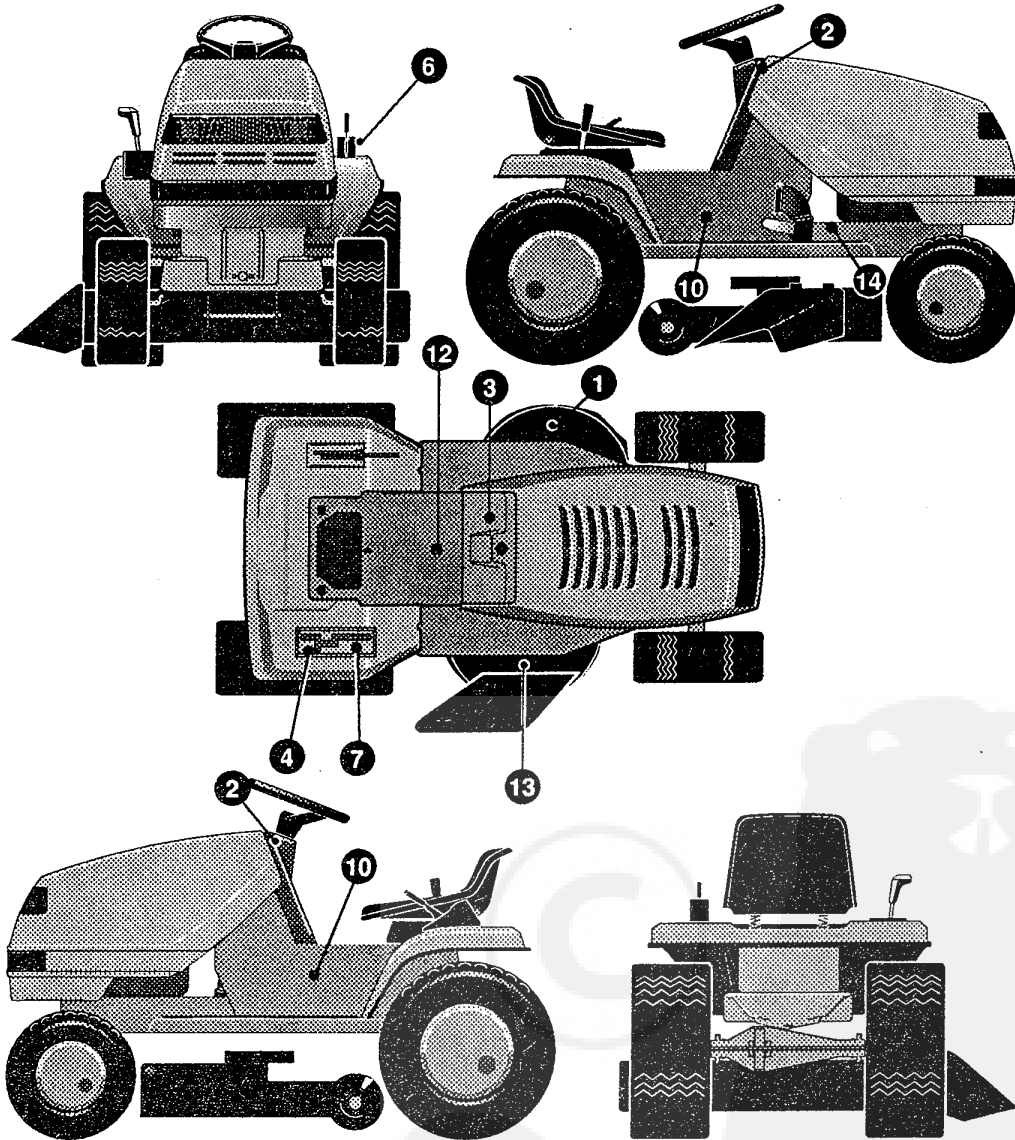

F3560-320

DECAL ASSEMBLY

KEY#	PART#	DESCRIPTION	QTY
1	402700	DECAL, CAUTION, DECK, LH	1
2	313208	DECAL, DASH, WEAR STRIP, RED	2
3	321765	DECAL, LF, DASH, PTO/LIGHT SWITCH, EXPORT	1
4	311394	DECAL, SHIFT REVERSE/NEUTRAL	1
6	402214	DECAL, HEIGHT ADJUST	1
7	331005	DECAL, SHIFTER POSITION, P930-6	1
10	402496	NAMEPLATE, 13/40	2
12	402689	DECAL, CONSOLE, SYMBOLIC, CAUTION	1
13	402701	DECAL, CAUTION, DECK, RH	1
14	402702	DECAL, BRAKE/CLUTCH	1

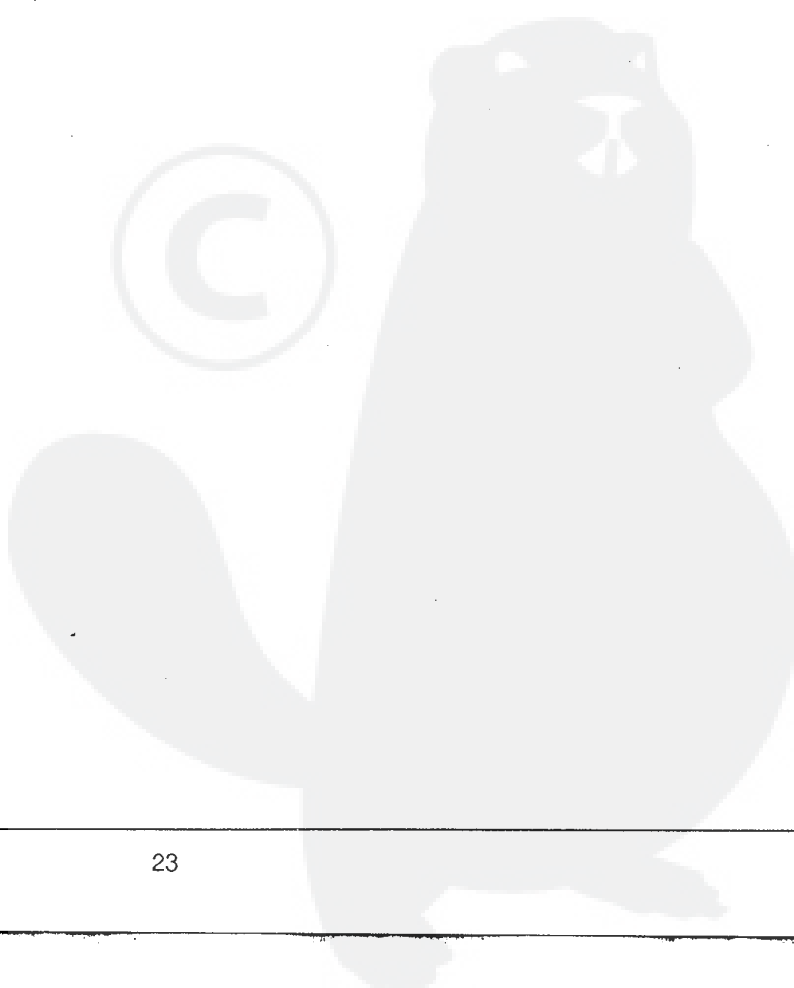

TREAD PATTERNS

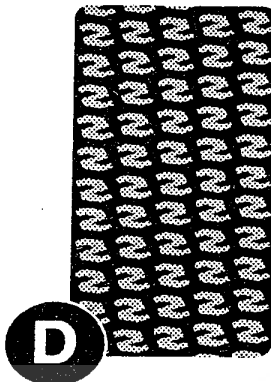
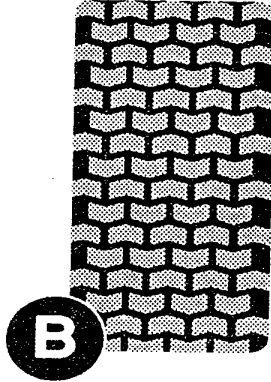
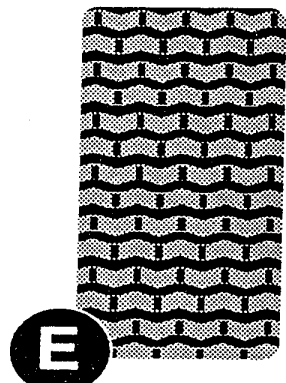
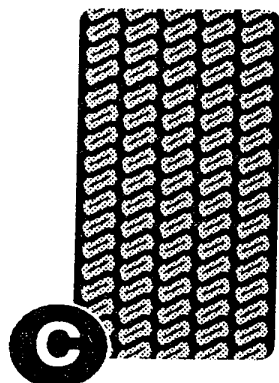
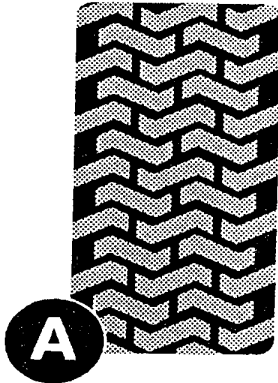

TIRE SIZE	"A"	"B"	"C"	"D"	"E"
11 X 4.00 - 5	42295	319679			
13 X 5.00 - 6	41060	319680			
15 X 6.00 - 6	39830	316702	301140	313952	
16 X 4.80 - 8		305035			
16 X 6.50 - 8	41081	319682		314539	
18 X 6.50 - 8		42091			
18 X 8.50 - 8	319683	317400			
18 X 9.50 - 8	41106	316701		313950	
20 X 8.00 - 8	319685	319684	57164	314584	331606
20 X 10.00 - 8	58276	319686		313654	
20 X 10.00 - 10	55893	319687			
23 X 9.50 - 12	53655	319690	319689	314370	

F3560-320

ACCESSORIES

Contact the dealer where your tractor was purchased for the available accessories. If you are unable to contact the dealer, write to the address on the warranty page of your Operator's manual.

LARGE LAWN TRACTOR

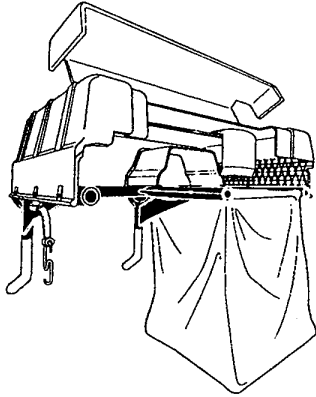

Model # 5708-34
Grass Collector for
40, 42, 43" decks

For heavy duty grass
collection order Model
#5709-10 Air Assist

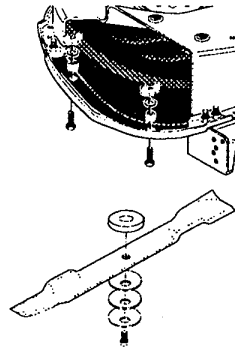

5717-00
Mulching Kit (42/43" Deck)
5716-00
Mulching Kit (40" Deck)

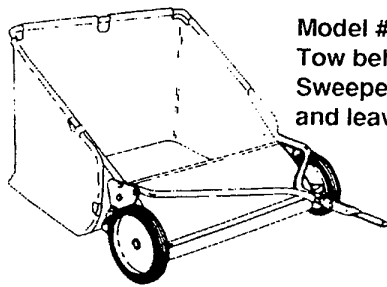

Model # 5648-16
Tow behind Lawn
Sweeper for grass
and leaves

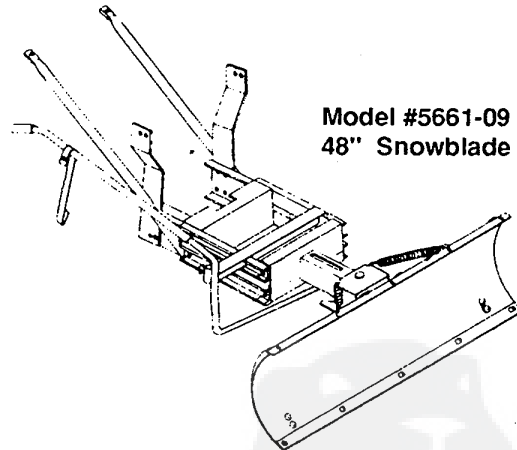

Model #5661-09
48" Snowblade

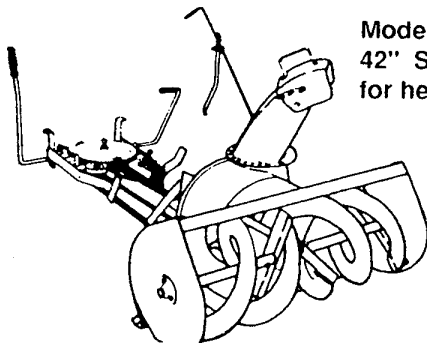

Model #5705-06
42" Snowthrower
for heavy snowfall

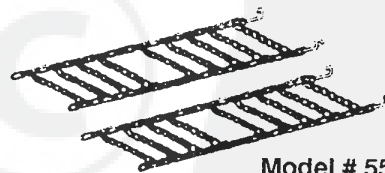

Model # 5585-00
Tire Chains - 20" x 8.0" tires
Model # 5706-00
Tire Chains - 20" x 10.0" tires

OTHER ACCESSORIES

Model	Description
5672-01	Wheel Weights - Front - 1 pr. w/mtg. hdw. - Fits 15" tires
5673-02	Wheel Weights - Rear - 1 pr. w/mtg. hdw. - Fits 18" & 20" tires
309070	40" High Lift Blade for Bagging or Side Discharge (Requires 2)
330277	40" Mulching Blade (Requires 2)
316608	43" High Lift Blade for Bagging or Side Discharge (Requires 2)
325762	43" Mulching Blade (Requires 2)