

PRICE:(¥)

Ref. No.	Part No.	Part Name	Q`ty	Recommend
i- i	38010-12110	CYLINDER	i	C
2	38010-12120	GASKET	1	B
3	22169-12190	BOLT	4	D
4	38010-12210	BOOTS	1	C
5	22182-12160	SPRING	1	D
6	22150-12170	SLEEVE	1	D
7	38010-12220	BRACKET	1	D
8	38010-12230	SEAL	1	C
9	11060-05141	BOLT ADHESIVE	3	D
10	38010-15010	MUFFLER ASSY	1	D
11	38010-15140	•TAIL PLATE	1	D
12	11203-05080	•SCREW PM	2	D
13	38010-15210	GASKET	1	B
14	11060-06200	BOLT ADHESIVE	4	D
15	22173-97111	PLUG	1	D
16	22173-16160	GASKET	1	B
17	68000-21010	CRANK CASE M COMP	1	-
18	68000-21110	•CRANK CASE M	1	D
19	12492-50100	•ROLLER	2	D
20	02030-06202	•BEARING	1	C
21	22155-21630	•OIL SEAL	1	B
22	22150-21220	•PULSE JOINT	1	D
23	38010-21020	CRANK CASE C COMP	1	-
24	38010-21210	•CRANK CASE C	1	D
25	02030-06203	•BEARING	1	C
26	22169-21630	•OIL SEAL	1	B
27	22169-21910	BOLT	6	D
28	72330-33710	CUSHION 26	4	C
29	22150-33720	PLUG 26	4	-
30	22169-33770	STOPPER BOLT	4	D
31	20050-87160	CUSHION	1	C
32	69014-41110	PISTON	1	C
33	22169-41210	PISTON RING	2	B
34	22169-41220	PISTON PIN	1	C
35	22155-41230	SNAP RING	2	B
36	22155-41281	BEARING SE	1	C
37	38010-42010	CRANK SHAFT	1	D
38	68000-71340	SWITCH ASSY	1	D

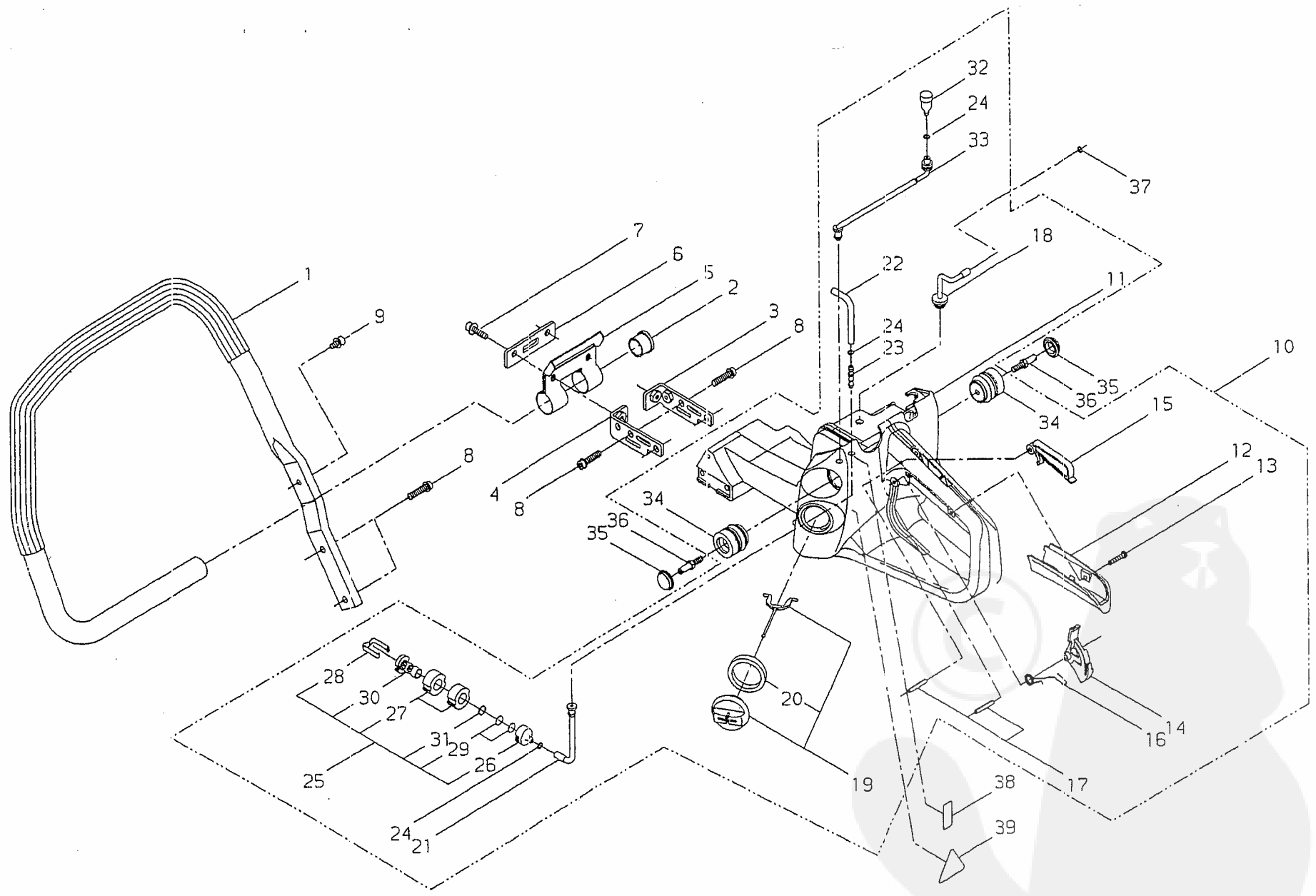



PRICE:(¥)

Ref. No.	Part No.	Part Name	Qty	Recommend
2-1	38010-32110	FRONT HANDLE	1	D
2	38010-32440	CAP	1	D
③	38010-32460	STAY RIGHT	1	D
④	38010-32470	STAY LEFT	1	D
5	38010-32330	BRACKET	1	D
⑥	38010-32480	PLATE	1	D
⑦	11060-05204	BOLT ADHESIVE	2	D
8	22169-32220	BOLT PC	6	D
9	11022-05100	BOLT SPW	1	D
10	38010-32025	REARHANDLE ASSY	1	-
11	38010-32211	•REAR HANDLE	1	D
12	22182-33230	•GRIP	1	D
13	01280-04202	•SCREW TAPPING	1	D
14	22182-33325	•THROTTLE LEVER	1	D
15	22182-33330	•LOCK LEVER	1	D
16	22182-33340	•SPRING LEVER	1	D
17	12420-40255	•SPRING PIN	2	D
18	38010-32371	•PIPE	1	C
⑱	38010-32041	•CAP ASSY	1	D
⑳	38010-32271	••GASKET	1	B
21	38010-32381	•PIPE	1	C
22	38010-32390	•PIPE	1	C
23	72933-85620	•JOINT	1	D
24	20020-85540	•CLIP	3	D
25	38010-32420	•FUEL FILTER SUB ASSY	1	A
26	22128-85410	••WEIGHT FUEL	1	D
27	38010-32430	••FILTER	2	A
28	22128-85440	••CLIP FILTER	1	D
29	22118-85460	••SCREEN	2	B
30	22128-85470	••SLEEVE	1	D
31	22128-85480	••RING	1	D
32	20800 33910	•VALVE	1	C
33	38010-32412	•PIPE	1	C
34	72330-33710	•CUSHION 26	2	C
35	22150-33720	PLUG 26	2	D
36	22150-33770	STOPPER BOLT 26	2	D
37	20020-85540	CLIP	1	D
⑳	19401-00256	LABEL INST	1	D



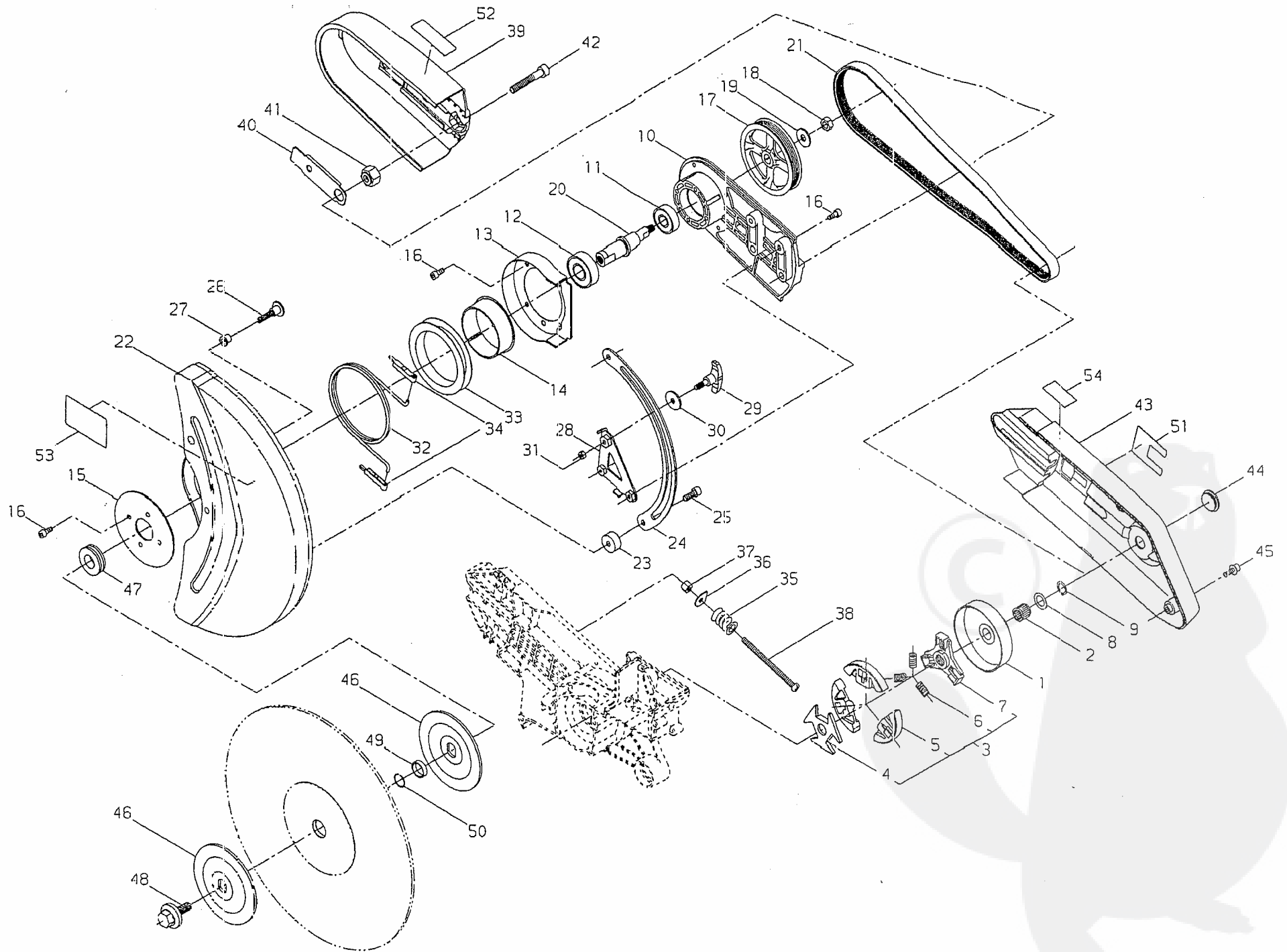

PRICE:(¥)

Ref. No.	Part No.	Part Name	Q'ty	Remarks	Recommend
3-1	38011-51110	CLUTCH DRUM	1	EC7600/CE	C
1	38010-51110	CLUTCH DRUM	1	EC7500/CE	C
2	38010-51320	NEEDLE BEARING	1		C
3	22169-51200	CLUTCH ASSY	1		C
4	22169-51210	•CLUTCH BOSS A	1		D
5	22169-51220	•CLUTCH SHOE	3		D
6	22150-51230	•CLUTCH SPRING	3		D
7	22169-51240	•CLUTCH BOSS B	1		D
8	22150-55120	THRUST PLATE	1		D
9	02430-13100	SNAP RING	1		B
10	38010-63110	BEARING CASE	1		D
11	02006-06201	BEARING	1		C
12	02006-06203	BEARING	1		C
13	38010-63330	SPRING PLATE	1		D
14	38010-63310	SLIDE RING	1		C
15	38010-63320	BEARING PLATE	1		D
16	01020-05160	BOLT	10		D
17	38010-64111	DRIVE PULLY	1		D
18	01500-08061	NUT	1		D
19	15401-20007	COLLAR	1		D
20	38010-64120	DRIVE SHAFT	1		D
21	38010-64130	DRIVE BELT	1		A
22	38011-65110	WHEEL GUARD	1	EC7600/CE	D
22	38010-65110	WHEEL GUARD	1	EC7500/CE	D
23	15401-20100	COLLAR	2		D
24	38010-65310	SLIDE PLATE	1		D
25	01020-06200	BOLT	2		D
26	20087-51210	BOLT	2		D
27	15401-00008	COLLAR	2		D
28	38010-65330	LOCK PLATE	1		D
29	38010-65342	KNOB	1		D
30	15401-20008	COLLAR	1		D
31	38010-65400	NUT	1		D
32	17520-98200	COIL SPRING	1		D
33	38010-65360	SPRING GUIDE	1		D
34	38010-65370	SPRING HOLDER	2		D
35	17500-17500	COIL SPRING	1		D
36	38010-66330	WASHER	1		D







PRICE:(¥)

Ref. No.	Part No.	Part Name	Q`ty	Recommend
4-1	38010-31111	CYLINDER COVER	1	D
2	17901-06100	•COLLAR	4	D
3	38010-31310	SEAL	1	C
4	38010-31321	SEAL SEAT	1	C
5	38010-67351	PLUG	1	C
6	22160-31150	BOLT SW	8	D
7	38010-71010	ROTOR ASSY	1	D
8	38010-71110	•ROTOR	1	D
9	22150-71120	•RATCHET	2	D
10	17520-14000	•COIL SPRING	2	D
11	22100-71430	•WASHER	2	D
12	22100-71441	•BOLT	2	D
13	02403-03100	KEY	1	D
14	22169-71460	NUT	1	D
15	38010-71212	COIL	1	D
16	38010-71320	TUBE	1	C
17	11022-04160	BOLT SPW	2	D
18	38010-71330	PLUG CAP	1	C
19	22154-72230	SPRING PLUG	1	B
20	14352-01700	LEAD WIRE	1	C
21	38010-75010	RECOIL STARTER ASSY	1	D
22	38010-75310	•RECOIL CASE	1	D
23	38010-75320	••OIL SEAL	1	B
24	38010-75330	•COVER	1	D
25	38010-75340	•REEL	1	D
26	38010-75410	•DRUM	1	D
27	38010-75360	•RECOIL SPRING	1	D
28	01500-06051	•NUT	1	D
29	38010-75370	•WASHER	1	D
30	32003-77370	•SCREW SPW	1	D
31	22104-75420	•KNOB RECOIL	4	D
32	22104-75430	•STOPPER KNOB	1	D
33	38010-75390	•ROPE	1	B
34	38010-75210	AIR PLATE	1	D
35	38010-82580	FILTER	1	A
36	38010-82311	PRE FILTER	1	A
37	38010-82560	SCREW PM SW	2	D
38	23627-21220	COLLAR	2	D



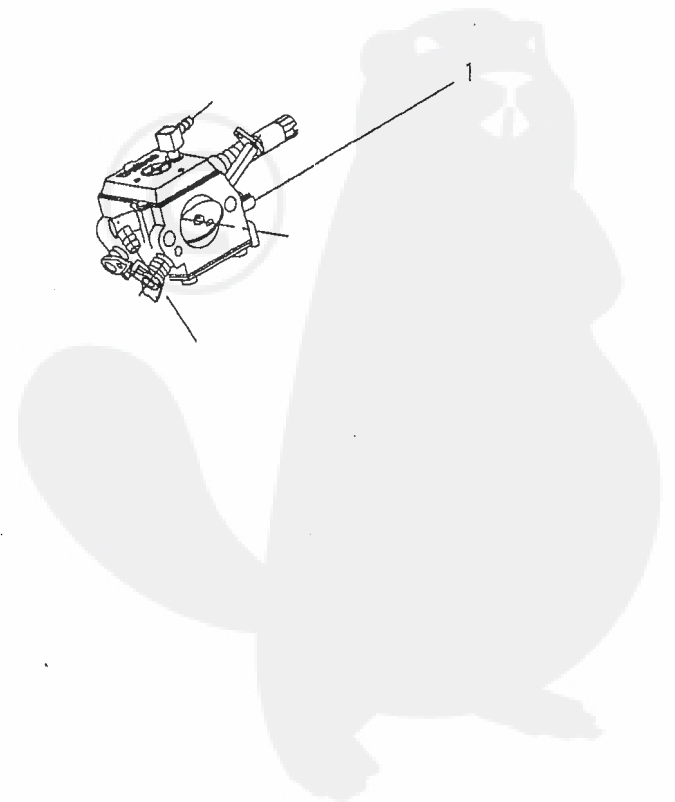
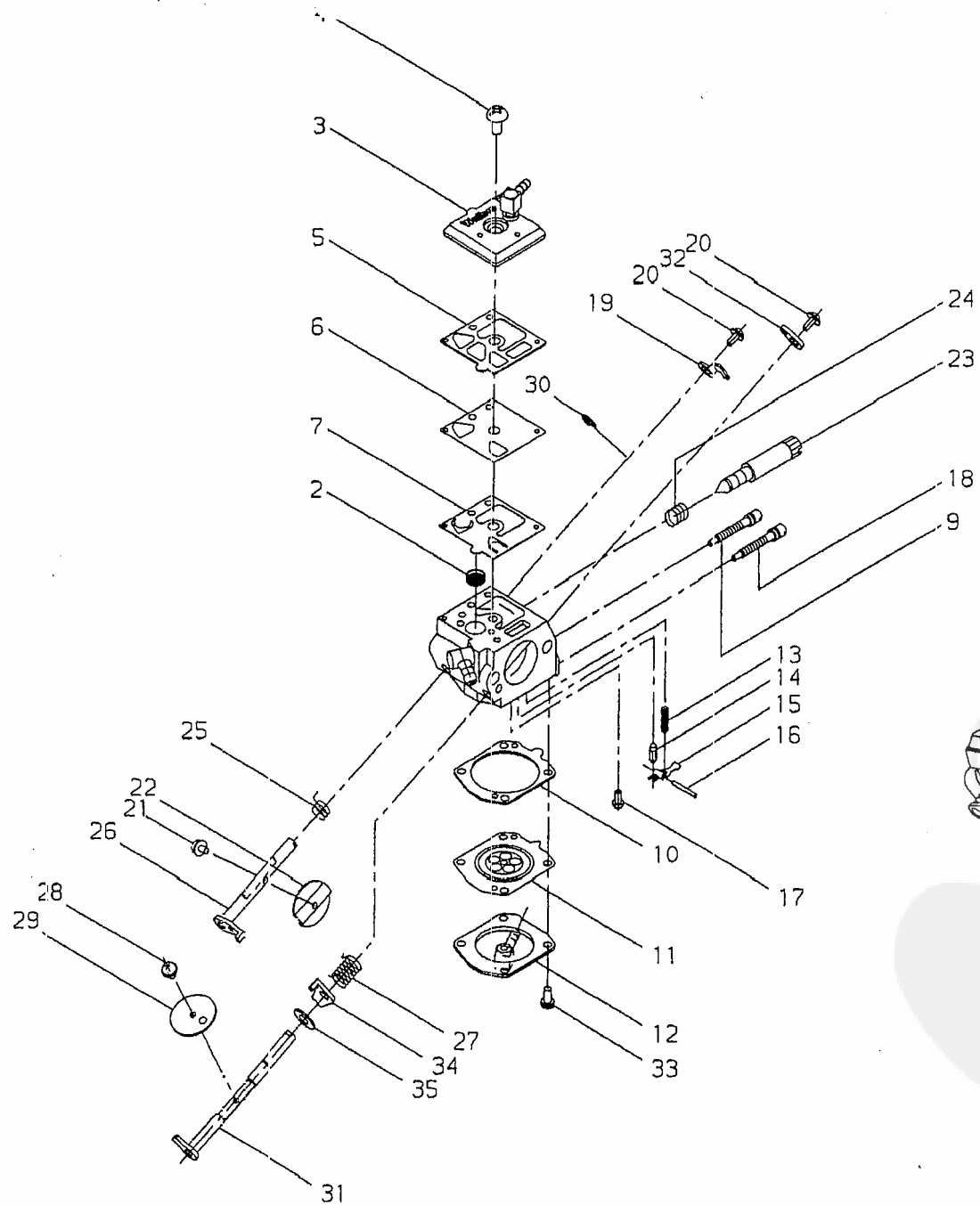

PRICE:(¥)

Ref. No.	Part No.	Part Name	Q`ty	Recommend
5-1	38010-81011	CABURETOR ASSY	1	D
2	70030-81380	•SCREEN	1	-
3	22150-81120	•PUMP COVER ASSY	1	-
4	22150-81130	•SCREW	1	-
5	22150-81140	•GASKET PUMP	1	-
6	22169-81180	•DIAPHRAGM PUMP	1	-
7	22169-81150	•DIAPHRAGM PUMP	1	-
9	38010-81430	•L NEEDLE	1	-
10	22150-81290	•GASKET DIAPHRAGM	1	-
11	22150-81260	•DIAPHRAGM ASSY	1	-
12	38010-81350	•COVER DIAPHRAGM	1	-
13	22150-81270	•SPRING LEVER	1	-
14	20036-81440	•NEEDLE VALVE	1	-
15	22150-81230	•LEVER	1	-
16	22100-81250	•PIN	1	-
17	22100-81240	•SCREW	1	-
18	38010-81361	•H NEEDLE	1	-
19	22160-81390	•STOPPER	1	-
20	22100-81360	•SCREW	2	-
21	20803-81140	•SCREW ASSY	1	-
22	22150-81340	•THROTTLE VALVE	1	-
23	22156-81410	•IDLE SCREW	1	-
24	22156-81420	•SPRING IDLE	1	-
25	22150-81430	•RETURN SPRING	1	-
26	38010-81370	•SHAFT ASSY	1	-
27	38010-81380	•SPRING	1	-
28	20803-81150	•SCREW ASSY	1	-
29	38010-81390	•CHOKE VALVE	1	-
30	70030-81390	•E RING	1	-
31	38010-81400	•SHAFT ASSY	1	-
32	22156-81380	•THROTT LEVER	1	-
33	22100-81351	•SCREW	1	-
34	38010-81420	•LEVER	1	-
35	20036-81185	•WASHER	1	-