

ILLUSTRATED

PARTS LIST

shindaiwa®

PIEZAS DE REPUESTO
LE RÉPERTOIRE DES PIÈCES ILLUSTRÉS



345

Revised Feb. 1992

FOREWORD

This PARTS LIST covers all the parts for SHINDAIWA Model 345.

RECOMMENDED QUANTITIES

1. Ranking

The following ranking such as A, B, C, and D is made in proportion to the part replacement frequency.

RANKING	DESCRIPTION	EXAMPLE
A	Parts, considered to be consumable or equivalent.	Filter
B	Parts, to be replaced at the time of disassembly and maintenance after one year's use.	Snap ring, Oil seal.
C	Parts, considered desirable to be replaced or sometimes to be replaced at the time of disassembly and maintenance.	Rubber parts, Bearing.
D	Parts, unnecessary for replacement except for breakage and missing.	Crankcase

PROLOGO

Esta lista cubre los repuestos y herramientas originales de la SHINDAIWA modelo 345.

RECOMENDACIONES PARA INVENTARIO

1. Clasificación

La siguiente clasificación: A, B, C y D ha sido preparada para ayudarle a determinar el número adecuado de piezas que deben mantenerse en inventario.

CLASIFICACION	DESCRIPCION	EJEMPLO
A	Piezas que se gastan bajo uso normal.	Resorte Filtro
B	Piezas que deben ser reemplazadas al hacer mantenimiento despues de un año de uso.	Anillos Pistón
C	Piezas que pueden ser cambiadas al hacer mantenimiento ó cuando hay que desarmar la maquina.	Cojinetes Boquillas
D	Piezas que deben ser reemplazadas cuando se dañan.	Carter del Motor

AVANT-PROPOS

Ceci est le répertoire des pièces pour le modèle SHINDAIWA 345.

QUANTITES RECOMMANDEES

1. Rang

Le classement suivant, tel que A, B, C, D, est établi en porportion de la fréquence de remplacement.

RANG	DESCRIPTION	EXEMPLE
A	Pièces considérées comme nécessitant leur remplacement pour usure normale.	Filtre
B	Pièces devant être remplacées lors d'un démontage ou pour maintenance après une année d'usage.	Anneaux blocants, Joints d'étanchéité
C	Pièces considérées comme devant être remplacées occasionnellement ou lors d'un démontage ou revisions.	Pièces de caoutchouc, Roulements.
D	Pièces ne nécessitant pas de remplacement autrement que par bris ou pertes.	Carter de manivelle

Use the chart at right to find recommended quantities for inventory, based on number of units sold per year.

Use este cuadro para encontrar las cantidades recomendadas que deben mantenerse en inventario, en relación a la cantidad de unidades vendidas.

Utiliser la charte de droite pour établir les quantités recommandées pour stockage, basées sur la quantité d'unités vendues par année.

RANKING	Recommended parts inventory for Inventario recomendado para Recommandations pour inventaire							
	30 UNIT	50 UNIT	100 UNIT	200 UNIT	300 UNIT	500 UNIT	1000 UNIT	3000 UNIT
A	6	10	20	35	45	70	120	270
B	4	8	15	25	35	50	80	160
C	2	6	10	15	20	30	50	100
D	1	2	5	8	10	15	20	50

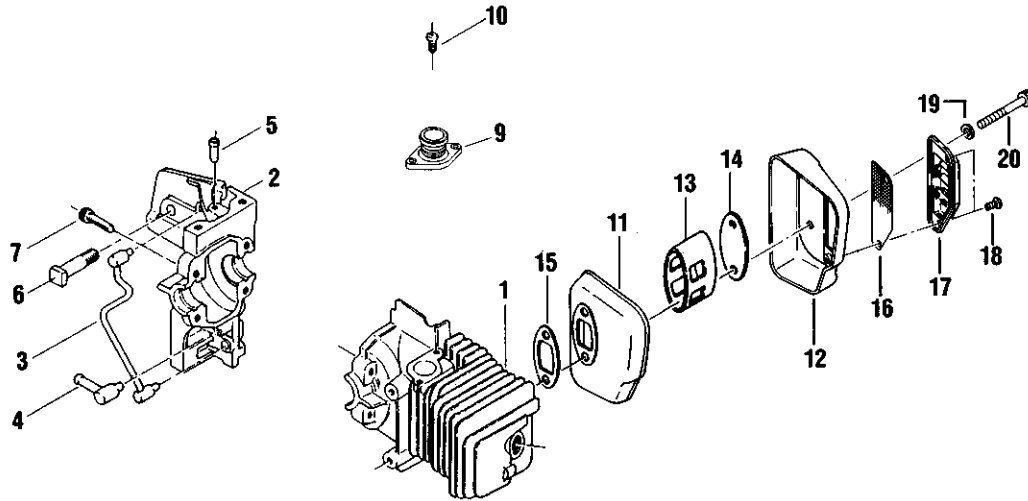
CYLINDER, CRANKCASE and MUFFLER**CILINDRO, CARTER y SILENCIADOR****CYLINDRE, CARTER DE MANIVELLE ET SILENCIEUX**

Index No. Indice	Part No. Pieza No. Numero	Description	Descripción	Description	Quant. Cant.	Serial No. Serie No.	Remarks Notas Note	Rank
1	22106-12110	CYLINDER	CILINDRO	CYLINDRE	1			D
	22140-12200	CRANKCASE ASSY.	CARTER COMPLETO	CARTER DE MANIVELLE	1			D
2		CRANKCASE	CARTER	CARTER DE MANIVELLE	1		ORDER 22140-12200	D
3	22106-12230	CRANKCASE OIL TUBE	TUBERIA DEL ACEITE	TUBE	1			D
4	22102-12240	CRANKCASE ELBOW	CODO	COUDE DE MANIVELLE	1		SB 13	D
5	22102-12250	PULSE JOINT	REGULADOR	JOINT	1			D
6	22120-12260	BAR BOLT	PERNO, BARRA	BOULON DE LA LAME	2			D
7	01020-05180	BOLT	PERNO	BOULON	4			D
9	22136-14130	BOOT	MANGA	BAGUE	1		REPLACES 22102-14130	B
10	11205-04140	SCREW	TORNILLO	VIS	2			D
	72159-15002	MUFFLER ASSY.	SILENCIADOR COMPLETO	SILENCIEUX COMPLET	1			D
11	22104-15110	MUFFLER BASE	SILENCIADOR BASE	SILENCIEUX BASE	1			D
12	72159-15120	MUFFLER COVER	SILENCIADOR TAPA	SILENCIEUX COUVERCLE	1			D
13	22135-15130	MUFFLER PIPE	TUBERIA, SILENCIADOR	TUYAU DU SILENCIEUX	1			D
14	22135-15140	MUFFLER PLATE	SILENCIADOR PLACA	SILENCIEUX PLAQUE	1			D
15	22115-15210	MUFFLER GASKET	EMPAQUETADURA	JOINT	1			A
16	72164-15150	SCREEN	GUARDACHISPAS	GRILLE	1			C
17	72159-15160	SCREEN COVER	TAPA, FILTRO	COUVERCLE DU FILTRE	1			D
18	01210-04080	SCREW	TORNILLO	VIS	2			D
19	22100-31210	WASHER	ARANDELA	RONDELLE	2			D
20	01020-05450	BOLT	PERNO	BOULON	2			D

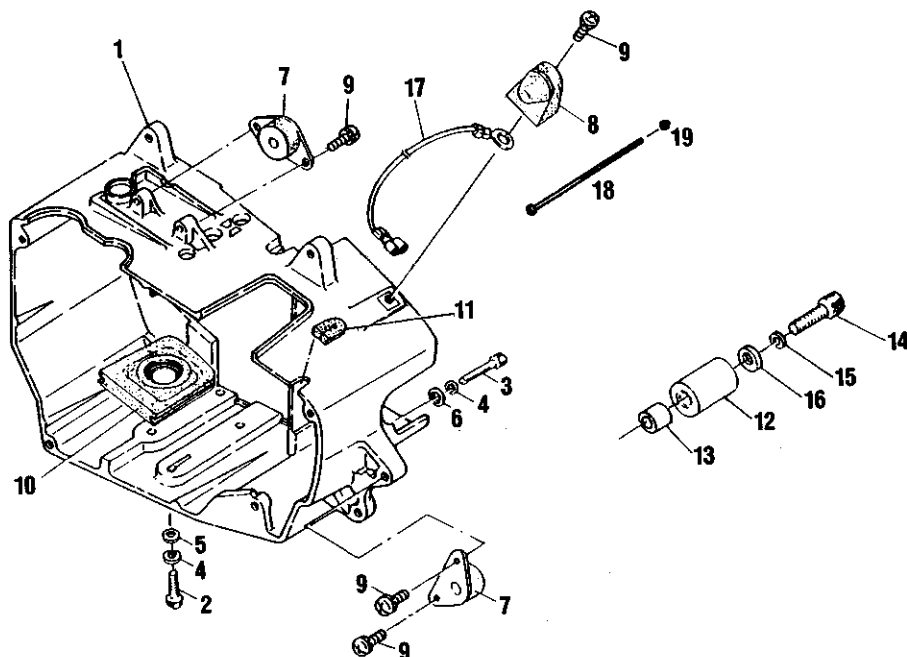

Index No. Indice	Part No. Pieza No. Numero	Description	Descripción	Description	Quant. Cant.	Serial No. Serie No.	Remarks Notas Note	Rank
1	22104-31111	ENGINE COVER	TAPA	CULASSE	1			D
2	01020-05180	BOLT	PERNO	BOULON	4			D
3	01020-05250	BOLT	PERNO	BOULON	1			D
4	01600-05131	SPRING WASHER	ARANDELA MUELLE	RONDELLE A RESSORT	5			D
5	01610-05080	WASHER	ARANDELA	RONDELLE	4			D
6	22100-31210	WASHER	ARANDELA	RONDELLE	1			D
7	22100-31310	MOUNT	MONTURA	PIECE DE MONTAGE	2			B
8	72229-31410	SIDE CUSHION	PROTECTOR	COUSSIN LATERAL	2			B
9	11204-05120	BOLT	PERNO	BOULON	6			D
10	22100-31510	SEAL	SELLO	JOINT D'ETANCHEITE	1			C
11	22100-31531	GROMMET	RETENEDOR	PASSE CABLE	1			C
12	22122-53410	CHAIN CATCHER	PROTECTOR	CAPTEUR DE CHAINE	1			B
13	22122-53420	BUSH	BOQUILLA	BAGUE	1			D
14	01020-05250	BOLT	PERNO	BOULON	1			D
15	01600-05131	SPRING WASHER	ARANDELA MUELLE	RONDELLE A RESSORT	1			D
16	22100-31210	WASHER	ARANDELA	RONDELLE	1			D
17	72170-33610	GROUND CORD	CORDÓN DE TIERRA	FIL DE MASSE	1			D
18	01210-04953	SCREW	TORNILLO	VIS	1			D
19	72229-31420	NUT	TUERCA	ECROU	1			D

HANDLE
MANGO Y GATILLO
POIGNEE

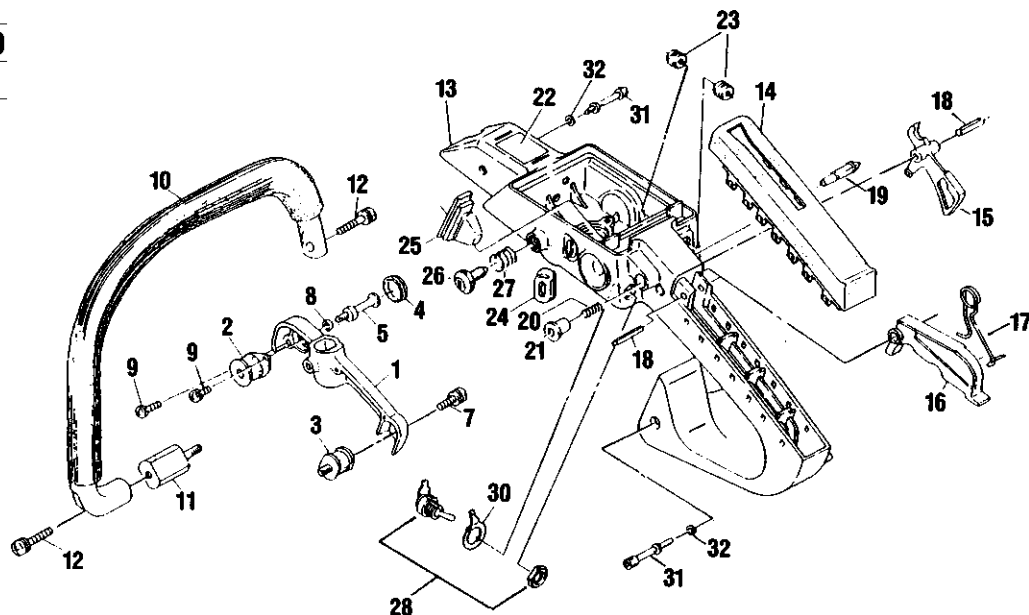

Index No. Indice	Part No. Pieza No. Numero	Description	Descripción	Description	Quant. Cart.	Serial No. Serie No.	Remarks Notas Note	Rank
1	72229-32110	BRACKET	ABRAZADERA	SUPPORT	1			D
2	22104-32120	CUSHION 22	AMORTIGUADOR 22	COUSSIN 22	1			C
3	22102-32130	CUSHION 18A	AMORTIGUADOR 18A	COUSSIN 18A	1			C
4	22102-32140	BRACKET PLUG	TAPON	BOUCHON, CONSOLE	1			D
5	22102-32181	BRACKET BOLT	PERNO	BOULON, CONSOLE	1			D
7	11206-05120	SCREW	TORNILLO	VIS	1			D
8	01600-05131	SPRING WASHER	ARANDELA MUELLE	RONDELLE A RESSORT	1			D
9	11204-04100	SCREW	TORNILLO	VIS	2			D
10	22104-32150	FRONT HANDLE	MANGO DELANTERO	POIGNEE AVANT	1			D
11	22135-32160	CUSHION 22B	AMORTIGUADOR 22B	COUSSIN 22B	1			B
12	11206-05250	SCREW	TORNILLO	VIS	1			D
	72229-33104	REAR HANDLE ASSY.	MANGO TRASERO COMPLETO	POIGNEE COMPLET	1			D
13		REAR HANDLE	MANGO TRASERO	POIGNEE ARRIERE	1		ORDER 72229-33104	D
14	22106-33120	HANDLE GRIP	CUBIERTA DE CAUCHO	POIGNEE	1			D
15	22104-33130	THROTTLE LEVER	ACELERADOR	LEVIER ACCELERATEUR	1			D
16	22104-33140	LOCK LEVER	GATILLO DE SEGURIDAD	LEVIER DE BLOCAGE	1			D
17	22106-33150	LEVER SPRING	RESORTE	RESSORT DU LEVIER	1			D
18	22100-33160	SPRING PIN	PASADOR	GOUPILLO	2			D
19	72171-33170	STOPPER	RETENEDOR	ARRET	1			D
20	22100-33180	SPRING	RESORTE	RESSORT	1			D
21	22100-33190	STOPPER KNOB	BOTON	BOUTON ARRET	1			D
22	19402-00024	CAUTION LABEL	PLACA DE AVISO	DECALQUE D'AVERTISSEMENT	1			D
23	22100-33310	GROMMET A	RETENEDOR A	PASSE CABLE	2			C
24	22100-33320	CARBURETOR GROMMET	RETENEDOR, CARBURADOR	PASSE CABLE CARBURATEUR	1			C
25	22100-33331	ROD GROMMET	RETENEDOR	ANNEAU DE TIGE	1			C
26	22122-33410	ADJUST SCREW	TORNILLO DE AJUSTE	VIS D'AJUSTEMENT	1			D
27	22122-33420	ADJUST SPRING	RESORTE	RESSORT D'AJUSTEMENT	1			D
28	72171-33500	SWITCH ASSY.	INTERRUPTOR COMPLETO	COMMUTATEUR	1			D
30	72171-33620	PLATE	PLACA	PLAQUE	1			C
31	22100-33810	BOLT	PERNO	BOULON	2			D
32	01600-05131	SPRING WASHER	ARANDELA MUELLE	RONDELLE A RESSORT	2			D

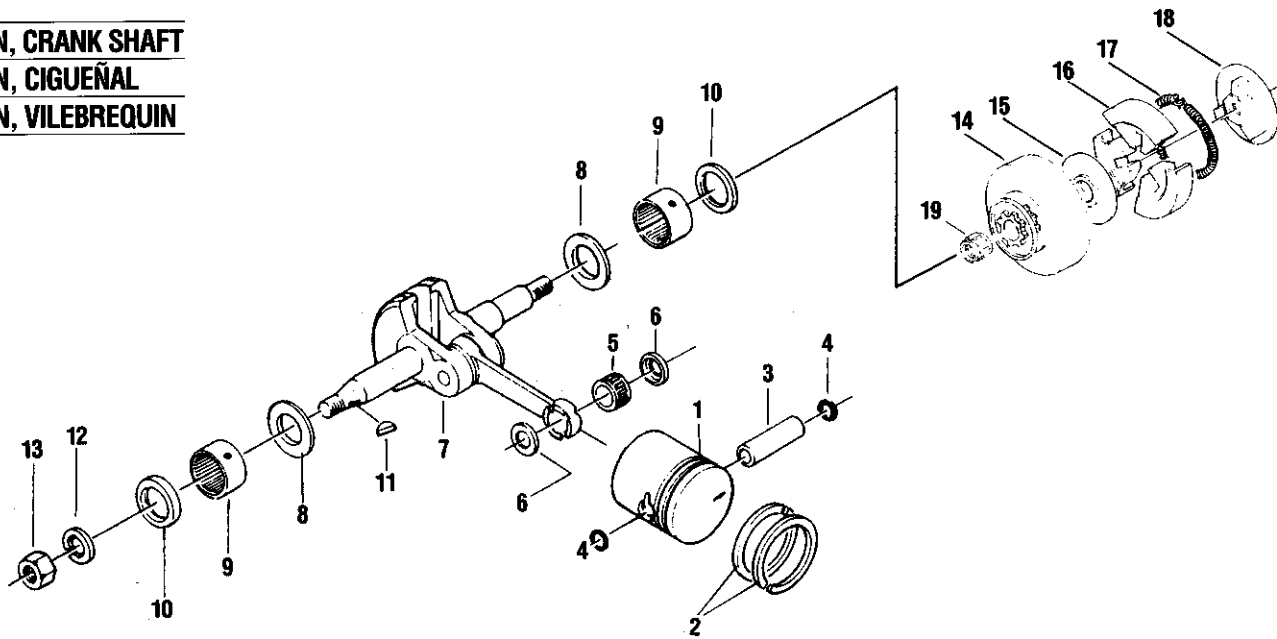

Index No. Índice	Part No. Pieza No. Numero	Description	Descripción	Description	Quant. Cant.	Serial No. Serie No.	Remarks Notas Note	Rank
	99909-115	PISTON ASSY.	PISTON COMPLETO	PISTON COMPLET	1			C
1	22106-41110	PISTON	PISTON	PISTON	1			C
2	20010-41210	PISTON RING	ANILLO PISTON	SEGMENT DE PISTON	2			B
3	22100-41220	PISTON PIN	PASADOR DEL PISTON	AXE DE PISTON	1			C
4	22100-41230	SNAP RING	ANILLO RETENEDOR	ANNEAU D'ARRET	2			B
5	20010-41330	BEARING (SE)	COJINETE (SE)	ROULEMENT A BILLE (SE)	1			C
6	22104-41340	THRUST WASHER	ARANDELA DE PRESION	RONDELLE A PRESSION	2			D
7	22128-42001	CRANKSHAFT ASSY.	CIGUEÑAL COMPLETO	VILEBREQUIN	1			D
8	22106-43110	THRUST WASHER	ARANDELA DE PRESION	RONDELLE A PRESSION	2			C
9	22100-43160	BEARING M	COJINETE M	ROULEMENT A BILLE M	2			C
10	22100-43170	OIL SEAL	RETEN	JOINT ETANCHEITE	2			B
11	22100-43210	KEY	CHAVETA	CLAVETTE	1			D
12	01600-08201	SPRING WASHER	ARANDELA MUELLE	RONDELLE A RESSORT	1			D
13	22100-43231	NUT	TUERCA	ECROU	1			D
14	22115-51110	CLUTCH DRUM (3/8" Spur)	TAMBOR DEL EMBRAGUE	TAMBOUR D'EMBRAYAGE	1		PR 73	C
	22115-51000	CLUTCH ASSY.	EMBRAGUE COMP.	ACCOUPLLEMENT COMPLET	1			C
15	22102-51210	CLUTCH BOSS A	CABEZA DEL EMBRAGUE A	ECROU A EMBRAYAGE	1			D
16	22100-51220	CLUTCH SHOE	ZAPATA DEL EMBRAGUE	SABOT D'EMBRAYAGE	3			B
17	22102-51230	CLUTCH SPRING	RESORTE DEL EMBRAGUE	RESSORT EMBRAYAGE	1			B
18	22104-51240	CLUTCH BOSS B	CABEZA DEL EMBRAGUE B	MOYEU D'EMBRAYAGE	1			B
19	22102-51310	BEARING	COJINETE	ROULEMENT A BILLE	1			C

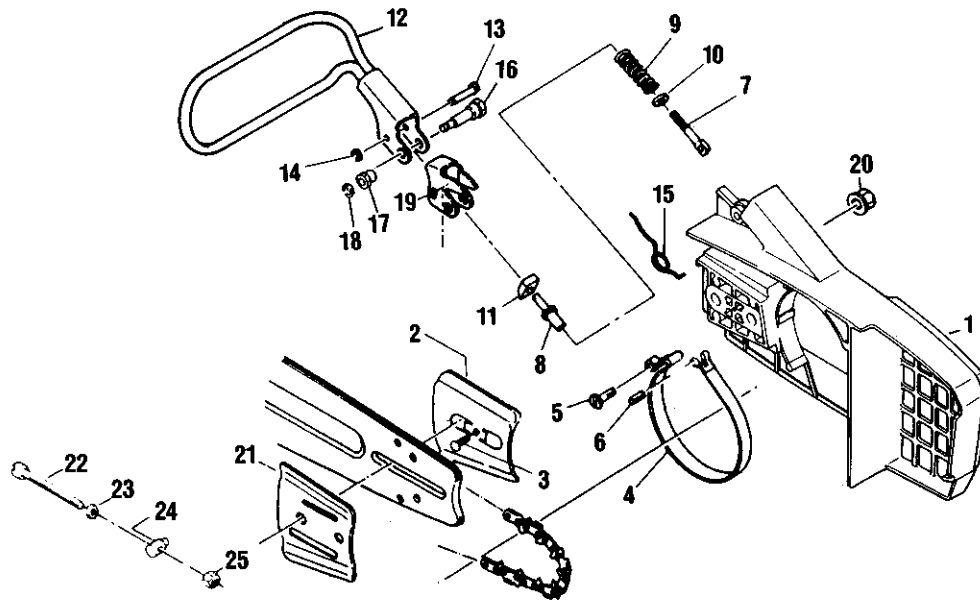

Index No. Indice	Part No. Pieza No. Numero	Description	Descripción	Description	Quant. Cant.	Serial No. Serie No.	Remarks Notas Note	Rank
	72159-54005	BRAKE ASSY.	FRENO COMPLETO	FREIN COMPLET	1			D
	72159-54100	CLUTCH COVER ASSY.	TAPA DEL EMBRAGUE COMPLETO	CAGE DE L'ACCOUPL	1			C
1		CLUTCH COVER	TAPA DEL EMBRAGUE	CAGE DE L'ACCOUPL	1		ORDER 72159-54100	C
2	22104-53120	GUIDE PLATE (B)	PLACA GUIA (B)	PLAQUE (B)	1			C
3	17100-25640	PARKER RIVET	REMACHE	RIVET PARKER	1			D
	72139-53130	NAME PLATE (A)	PLACA DE LA MARCA (A)	PLAQUE IDENTIFICATION	1			D
4	22116-54210	BRAKE BAND	BANDA DE FRENO	BANDE DE FREIN	1			D
5	22120-54220	BOLT BAND	PERNO	BOULON, BANDE	1			D
6	22120-54230	SPRING PIN	PASADOR	GOUILLE DE RESSORT	1			D
7	72152-54310	ADJUST ROD	PERNO DE AJUSTE	TIGE D'AJUS	1			D
8	72152-54320	ADJUST SCREW	TORNILLO DE AJUSTE	VIS D'AJUSTEMENT	1			D
9	22120-54330	BRAKE SPRING	RESORTE DEL FRENO	RESSORT DE FREIN	1			D
10	22120-54340	WASHER	ARANDELA	RONDELLE	1			D
11	22120-54410	BLOCK	RETENEDOR	BLOC	1			D
12	22135-54510	LEVER	PALANCA	LEVIER	1			D
13	22135-54520	STOP PIN	PASADOR	GOUILLE D'ARRET	1			D
14	22120-54530	E-RING	SEGURO DEL PASADOR	RONDELLE DE BLOCAGE	1			D
15	22135-54540	RELIEF SPRING	RESORTE	RESSORT DE RELACHE	1			D
16	72229-54580	LEVER BOLT	PERNO	BOULON, LEVIER	2			D
17	72229-54590	NUT, LEVER	TUERCA	ECROU	1			D
18	02434-30060	E-RING	SEGURO DEL PASADOR	RONDELLE DE BLOCAGE	1			D
19	72171-54560	LEVER (C)	PALANCA (C)	LEVIER (C)	1			D
20	22120-53210	NUT	TUERCA	ECROU	2			A
21	22100-53340	GUIDE PLATE (A)	PLACA GUIA (A)	PLAQUE (A)	1			C
22	22100-53310	ADJUST SCREW	TORNILLO DE AJUSTE	VIS D'AJUSTEMENT	1			A
23	01610-05080	WASHER	ARANDELA	RONDELLE	1			D
24	22100-53320	ADJUSTING STUD	PASADOR AJUSTE	GO. D'AJUST	1			A
25	22100-53330	LOCK NUT	TUERCA	ECROU D'AR	1			A

OIL PUMP

ACEITADOR AUTOMATICO

POMPE A L'HUILE

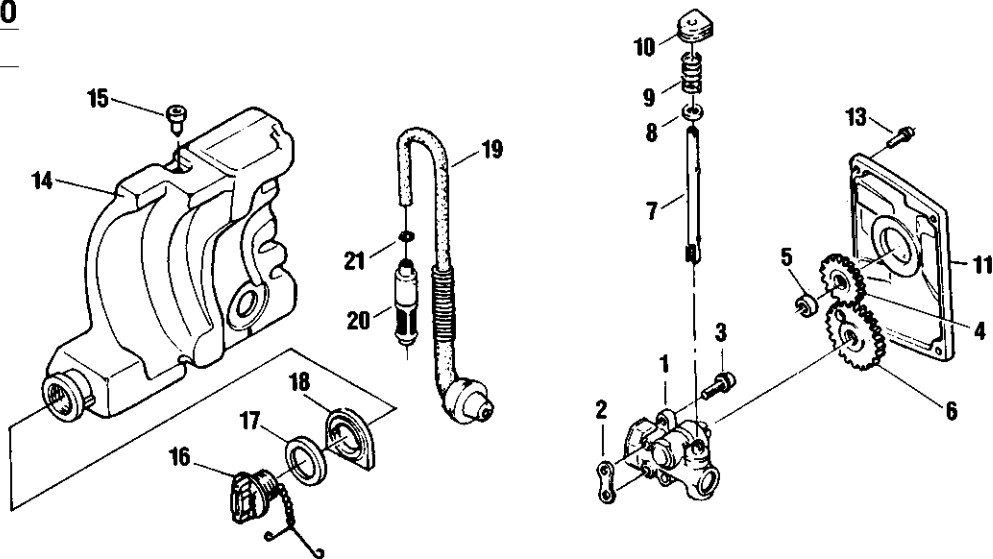

Index No. Indice	Part No. Pieza No. Numero	Description	Descripción	Description	Quant. Cant.	Serial No. Serie No.	Remarks Notas Note	Rank
1	22136-55200	OIL PUMP ASSY.	BOMBA DE ACEITE	POMPE A L'HUILE	1			D
2	22100-55310	OIL PUMP GASKET	EMPAQUETADURA	JOINT DE LA POMPE	1			B
3	11206-04140	SCREW	TORNILLO	VIS	2			D
4	22102-55130	PINION	ENGRANAJE	GOUILLE	1			D
5	22102-55141	COLLAR	COLLAR	COLLET	1			D
6	22128-55120	GEAR	ENGRANAJE	ENGRENAGE	1			D
7	22100-55610	OIL PUMP SHAFT	EJE, BOMBA DE ACEITE	AXE, POMPE A L'HUILE	1			D
8	01610-04050	WASHER	ARANDELA	RONDELLE	1			D
9	22100-55640	SPRING	RESORTE	RESSORT	1			D
10	22100-55650	OIL PUMP GROMMET	REtenedor	ANNEAU POMPE	1			C
11	22104-56110	PUMP COVER	TAPA DE LA BOMBA	COUVERCLE DE LA POMPE	1			C
13	11205-04140	SCREW	TORNILLO	VIS	5			D
	72247-57001	OIL TANK ASSY.	TANQUE DE ACEITE COMPLETO	RESERVOIR	1		PR 70	D
14		OIL TANK	TANQUE DE ACEITE	RESERVOIR	1		ORDER 72247-57001	D
15	22115-57120	OIL TANK VALVE	VALVULA	SOUPAPE DU RE. A L'HUILE	1		PR 70	C
	22128-57200	OIL CAP ASSY.	TAPA DE TANQUE COMPLETO	BOUCHON COMPLET	1			D
16		OIL CAP	TAPA DE TANQUE	BOUCHON	1		ORDER 22128-57200	D
17	22100-57230	OIL CAP GASKET	EMPAQUETADURA	JOINT, BOUCHON HUILE	1			B
18	22122-57240	SUPPORT	SOPORTE	SUPP. RES. A L'HUILE	1			C
	22122-57301	OIL TUBE ASSY.	TUBERIA DE ACEITE COMPLETA	TUYAU A L'HUILE COMPLET	1			C
19		OIL TUBE	TUBERIA DE ACEITE	TUYAU A L'HUILE	1		ORDER 22122-57301	C
20	22100-57360	OIL FILTER	FILTRO DE ACEITE	FILTRE HUILE	1			D
21	22100-57370	OIL FILTER CLIP	SUJETADOR DE FILTRO	ATTACHE FILTRE HUILE	1			D

345

IGNITION SYSTEM

SISTEMA DE ENCENDIDO

ALLUMAGE

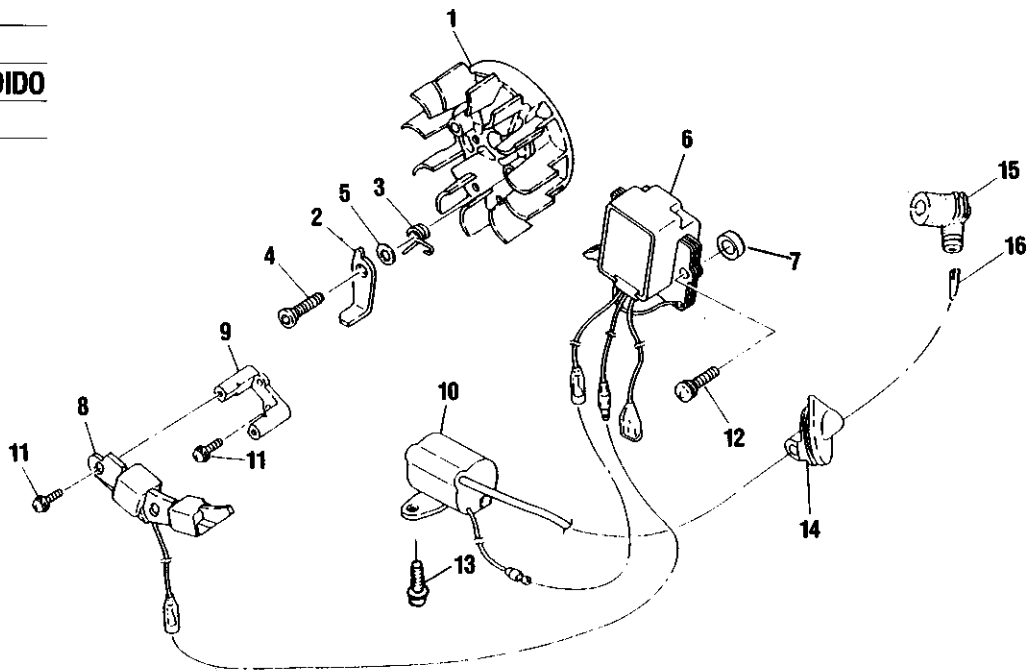

Index No. Indice	Part No. Pieza No. Numero	Description	Descripción	Description	Quant. Cant.	Serial No. Serie No.	Remarks Notas Note	Rank
	22108-71100	ROTOR ASSY.	VOLANTE COMPLETA	ROTOR	1			D
1		ROTOR	VOLANTE	ROTOR	1		ORDER 22108-71100	D
2	22106-71410	RATCHET	TRINQUETE	ROCHET	2			D
3	22106-71421	RATCHET SPRING	RESORTE	RESSORT ROCHET	2			D
4	22106-71441	RATCHET PIN	PASADOR	GOUPILLE	2			D
5	22100-71430	WASHER	ARANDELA	RONDELLE	2			D
6	22108-71500	EXCITER COIL	CONDENSADOR	BOBINE	1			D
7	22106-71810	INSULATOR	AISLADOR	ISOLATEUR	2			C
8	22108-71610	PULSER COIL	CONDENSADOR	BOBINE	1			D
9	22108-71620	PULSER BRACKET	ABRAZADERA	CONSOLE	1			D
10	22108-71700	IGNITION COIL	BOBINA	BOBINE D'ALLUMAGE	1			D
11	11206-04140	SCREW	TORNILLO	VIS	4			D
12	11022-05200	BOLT	PERNO	BOULON	2			D
13	11206-04100	SCREW	TORNILLO	VIS	2			D
14	22104-72210	GROMMET	RETENEDOR	PASSE CABLE	1			C
15	20010-72221	PLUG CAP	TAPON DE BUJIA	BOUCHON	1			A
16	20000-72230	SPARK PLUG SPRING	ARANDELA DE BUJIA	RESSORT BOUGIE	1			A

345

STARTER ARRANCADOR DEMARREUR

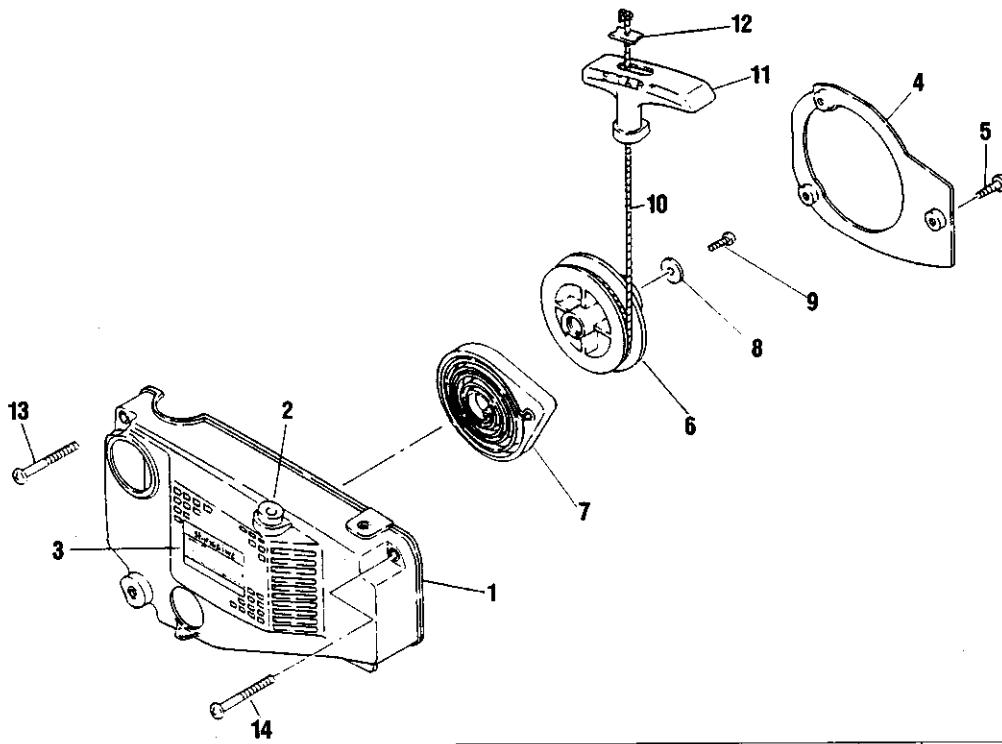

Index No. Indice	Part No. Pieza No. Numero	Description	Descripción	Description	Quant. Cant.	Serial No. Serie No.	Remarks Notas Note	Rank
	72229-75000	RECOIL STARTER ASSY.	ARRANCADOR COMPLETO	DEMARREUR COMPLET	1			D
1	22106-75100	RECOIL CASE	TAPA	CAGE DU DEMARREUR	1			D
2	22106-75130	GUIDE	GUIA	GUIDE	1			C
3	72229-75120	NAME PLATE	PLACA DE LA MARCA	PLAQUE IDENTIFICATION	1			D
4	22106-75150	AIR PLATE	PLACA	PLAQUE	1			D
5	22106-75160	SCREW	TORNILLO	VIS	3			D
6	22106-75210	REEL	TAMBOR	BOBINE	1			C
7	22106-75310	RECOIL SPRING	RESORTE ESPIRAL	RESSORT DE RAPPEL	1			C
8	22104-75350	WASHER	ARANDELA	RONDELLE	1			C
9	11204-04100	SCREW	TORNILLO	VIS	1			D
10	22104-75410	ROPE	CUERDA	CORDE	1			B
11	22104-75420	KNOB	ASIDERO	POIGNEE DU DEMARREUR	1			C
12	22104-75430	STOPPER	RETENEDOR	ARRET	1			C
13	11206-04350	SCREW	TORNILLO	VIS	2			D
14	11206-04200	SCREW	TORNILLO	VIS	2			D

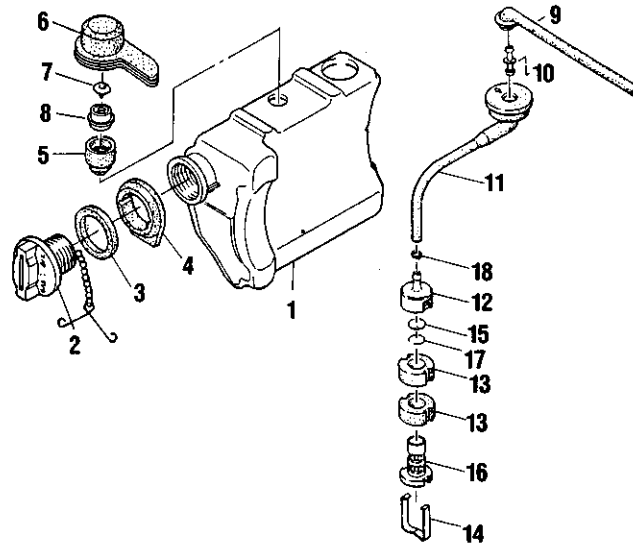
FUEL TANK**TANQUE DEL COMBUSTIBLE****RESERVOIR ESSENCE**

Index No. Indice	Part No. Pieza No. Numero	Description	Descripción	Description	Quant. Cant.	Serial No. Serie No.	Remarks Notas Note
	72116-85001	FUEL TANK ASSY.	TANQUE DE COMBUSTIBLE COMP.	RESERVOIR A ESSENCE	1		
1	22135-85110	FUEL TANK	TANQUE DE COMBUSTIBLE	RESERVOIR A ESSENCE	1		ORDER 72116-85001
	22128-85200	FUEL CAP ASSY.	TAPA DEL TANQUE COMPLETO	BOUCHON DU RESERVOIR D'ESSENCE	1		
2		FUEL CAP	TAPA DEL TANQUE	BOUCHON DU RESERVOIR D'ESSENCE	1		ORDER 22128-85200
3	22100-85281	GASKET, FUEL CAP	EMPAQUETADURA	JOINT	1		
4	22122-85230	SUPPORT, FUEL	SOPORTE, DEL TANQUE	SUPPORT	1		
5	22122-85240	HOLDER, VALVE	SOPORTE, VALVULA	SOUPAPE DE RETENU	1		
6	22122-85250	CAP, BREATHER	TAPA, VENTILACION	PRISE D'AIR BOUCHON	1		
7	22100-85260	VALVE, FUEL	VALVULA, TAPA	SOUPAPE CARBURANT	1		
8	22122-85270	RETAINER, BREATHER	RETENEDOR	ATTACH PRISE D'AIR	1		
9	22104-85310	FUEL TUBE	MANGUERA COMBUSTIBLE	TUYAU A ESSENCE	1		
10	22100-85320	JOINT, FUEL TUBE	CONECTOR	ATTACH TUYAU CARB.	1		
	22128-85301	FUEL PICKUP TUBE ASSY.	TUBERIA DE SUCCION COMPLETO	TUYAU A L'HUILE COMPLET	1		
11	22128-85400	FUEL PICKUP TUBE	TUBERIA DE SUCCION	TUYAU HUILE	1		
	22115-85401	FUEL FILTER ASSY.	FILTRO DE COMBUSTIBLE	FILTRE A ESSENCE	1		
12	22128-85410	WEIGHT, FUEL TUBE	PESA	ANCRE	1		
13	22128-85421	FILTER	FILTRO	FILTRE A	2		
14	22128-85440	CLIP, FILTER	SUJETADOR	ATTACHE	1		
15	22118-85461	SCREEN	GUARDACHISPAS	GRILLE	1		
16	22128-85470	SLEEVE	TUBO	TUYAU	1		
17	22128-85480	RING	ANILLO	RONDELLE	1		
18	20020-85540	CLIP	SUJETADOR	ATTACHE	1		

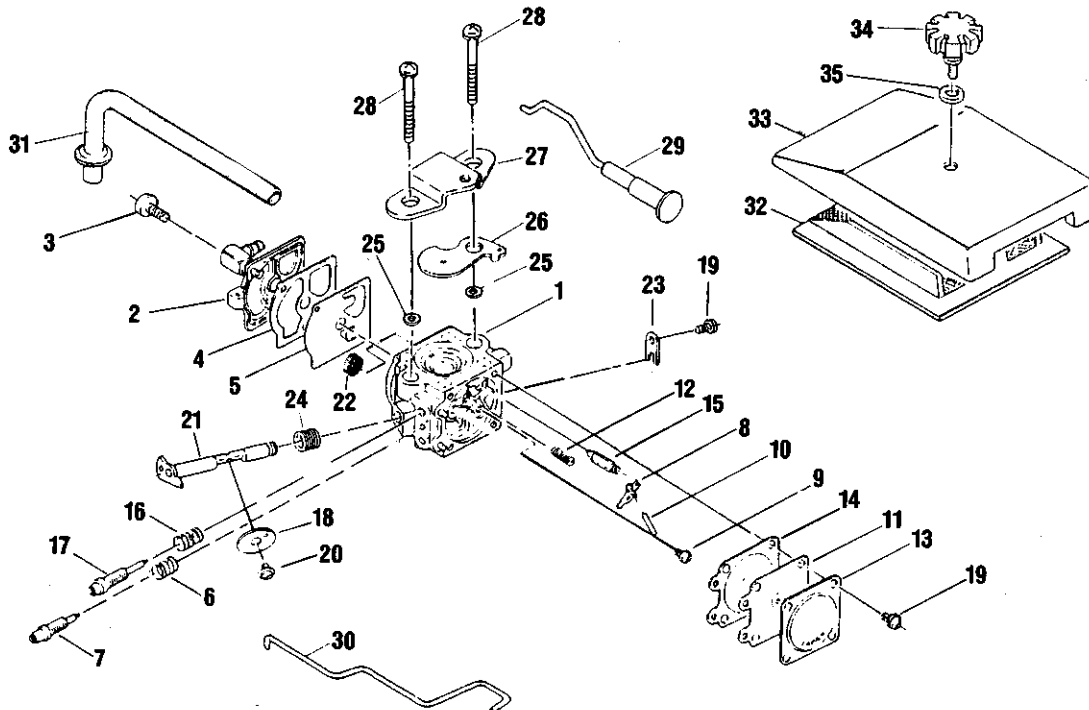
CARBURETOR
CARBURADOR
CARBURATEUR

Index No. Indice	Part No. Pieza No. Numero	Description	Descripción	Description	Quant. Cant.	Serial No. Serie No.	Remarks Notas Note	Rank
	22104-81000	CARBURETOR ASSY.	CARBURADOR COMPLETO	CARBURATEUR	1			C
1		CARBURETOR BODY	CUERPO	CORPS	1		ORDER 22104-81000	C
2	22128-81120	PUMP COVER ASSY	TAPA DE LA BOMBA	COUVERCLE DE POMPE	1			D
3	22100-81130	SCREW	TORNILLO	VIS	1			D
4	22128-81140	PUMP COVER GASKET	EMPAQUETADURA	JOINT	1			A
5	22128-81150	PUMP DIAPHRAGM	DIAFRAGMA, BOMBA	MEMBRANES	1			A
6	22100-81160	IDLE NEEDLE SPRING	RESORTE, AGUJA	RESSORT DE LA VIS DU RALENTI	1			D
7	22104-81170	L NEEDLE	AGUJA, BAJA VEL	VIS DE REGLAGE "L"	1			D
8	22100-81230	LEVER	PALANCA	LEVIER	1			D
9	22100-81240	SCREW	TORNILLO	VIS	1			D
10	22100-81250	PIN	PASADOR	GOUPILLE	1			D
11	22100-81260	DIAPHRAGM ASSY.	DIAFRAGMA COMPLETO	MEMBRANE	1			A
12	22104-81270	LEVER SPRING	RESORTE	RESSORT DU LEVIER	1			D
13	22100-81280	DIAPHRAGM COVER	TAPA DIAFRAGMA	COUVERCLE MEMBRANE	1			D
14	22100-81290	DIAPHRAGM GASKET	EMPAQUETADURA	JOINT	1			A
15	22100-81310	NEEDLE VALVE	AGUJA VALVULA	POINTEAU	1			D
16	22100-81320	H NEEDLE SPRING	RESORTE AGUJA ALTA VEL	RESSORT	1			D
17	22104-81330	H NEEDLE	AGUJA ALTA VEL	VIS DE REGLAGE "H"	1			D
18	22104-81340	THROTTLE VALVE	VALVULA	SOUPAPE D'ACCELERATEUR	1			D
19	22100-81351	SCREW ASSY.	TORNILLOS CONJUNTO	VIS COMPLET	5			D
20	22100-81360	SCREW	TORNILLO	VIS	1			D
21	22100-81370	SHAFT ASSY.	EJE COMPLETO	AXE COMPLET	1			D
22	22128-81380	SCREEN	GUARDACHISPAS	GRILLE	1			D
23	22100-81390	SHAFT CLIP	SUJETADOR DEL EJE	ANNEAU D'ARRET AXE	1			D
24	22100-81410	SHAFT SPRING	RESORTE EJE	RESSORT AXE	1			D
25	22100-82110	CARBURETOR WASHER	ARANDELA, CARBURADOR	RONDELLE CARBURATEUR	2			C
26	22120-82120	SHUTTER PLATE	PLACA DE CIERRE	PAPILLON	1			D
27	22100-82130	BRACKET	ABRAZADERA	SUPPORT	1			D
28	11204-05400	SCREW	TORNILLO	VIS	2			D
29	22102-82140	CHOKE ROD	VARILLA DEL ESTRANGULADOR	TIGE DE L'ETRANGLEUR	1			D
30	22115-82210	THROTTLE ROD	VARILLA DEL ACELERADOR	TIGE ACCELERATEUR	1		PR 57	D
31	22104-82220	IMPULSE TUBE	TUBERIA DEL REGULADOR	TUYAU A PULSION	1			C
32	22102-97521	FLOCKED AIR CLEANER	FILTRO DE AIRE	FILTRE A AIR	1			C

Index No. Indice	Part No. Pieza No. Numero	Description	Descripción	Description	Quant. Cant.	Serial No. Serie No.	Remarks Notas Note	Rank
	22100-82400	CLEANER COVER ASSY.	TAPA DEL FILTRO COMPLETO	COUVERCLE FILTRE A AIR	1			C
33		CLEANER COVER	TAPA DEL FILTRO	COUVERCLE DU FILTRE	1		ORDER 22100-82400	D
34	22100-82420	CLEANER COVER KNOB	BOTON	BOUTON	1			C
35	22100-82430	O-RING	ANILLO	JOINT TORIQUE	1			C
	22100-81200	KWIK KIT	KIT	ENSEMBLE DE PIECES	1			C
8		LEVER	PALANCA	LEVIER	1			D
9		SCREW	TORNILLO	VIS	1			D
10		PIN	PASADOR	GOUPILLE	1			D
15		NEEDLE VALVE	AGUJA VALVULA	POINTEAU	1			D
12		SPRING LEVER	RESORTE EJE	RESSORT LEVIER	1			D
22		SCREEN	GUARDACHISPAS	GRILLE	1			D
	22128-81100	GASKET & DIAPHRAGM KIT	JUEGO DE DIAFRAGMA Y	ENSEMBLE DE MEMBRANES EMPAQUETADURAS	1			C
5		PUMP DIAPHRAGM	DIAFRAGMA, BOMBA	MEMBRANES	1			A
11		DIAPHRAGM ASSY.	DIAFRAGMA COMPLETO	MEMBRANE COMPLET	1			A
4		PUMP COVER GASKET	EMPAQUETADURA	JOINT COUVERCLE DE POMPE	1			A
14		DIAPHRAGM GASKET	EMPAQUETADURA	JOINT MEMBRANE	1			A

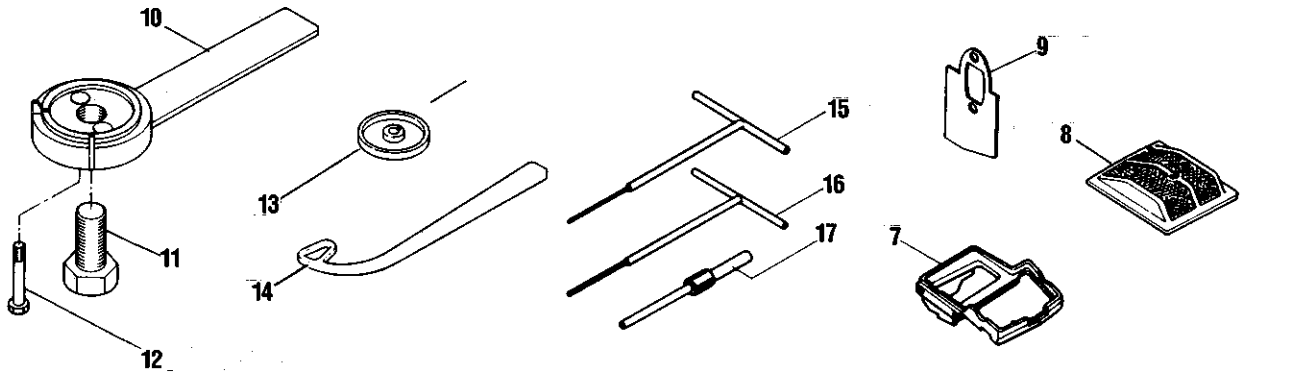
ACCESSORY AND OPTIONAL PARTS**ACCESORIOS, HERRAMIENTAS Y PIEZAS OPCIONALES****ACCESSOIRES ET PIECES OPTIONEL**

Index No. Indice	Part No. Pieza No. Numero	Description	Descripción	Description	Quant. Cant.	Serial No. Serie No.	Remarks Notas Note	Rank
	72142-91000	TOOL SET	JUEGO DE HERRAMIENTAS	JEUX D'OUTILS	1			D
1		TOOL BAG	BOLSA DE HERRAMIENTAS	SAC A OUTILS	1		ORDER 72142-91000	D
2	22102-91410	PLUG WRENCH	LLAVE DE BUJIA	CLE A BOUGIES	1			A
3	22100-91561	WRENCH (5)	LLAVE (5)	CLÉ (5)	1			D
4	22135-57610	SPIKE	UÑAS	BUTOIR	1			B
5	01020-05120	BOLT	PERNO	BOULON	2			D
6	01600-05131	SPRING WASHER	ARANDELA MUELLE	RONDELLE A RESSORT	2			D
7	22102-97510	AIR DUCT	DUCTO DEL AIRE	CONDUIT D'AIR	1			D
8	22102-82310	STAINLESS AIR CLEANER	FILTRO DEL AIRE	FILTRE AIR	1			A
9	22102-97540	MUFFLER GASKET	EMPAQUETADURA	JOINT	1			D
	22104-96000	OPTIONAL TOOL SET	JUEGO DE HERRAMIENTAS	JEU D'OUTILS	1			D
10	22104-96110	PULLER	EXTRACTOR	EXTRACTEUR	1			D
11	22100-96121	CENTER BOLT	PERNO CENTRAL	BOULON CENTRAL	1			D
12	22102-96130	BOLT	PERNO	BOULON	2			D
13	22106-96210	SET GAUGE	ESPACIADOR	JAUGE D'EPaisseur	1			D
14	22100-96410	STOPPER	RETENEDOR	ARRET	1			D
15	22102-96510	T-WRENCH (4)	LLAVE T (4)	CLÉ (4)	1			D
16	22102-96520	T-WRENCH (5)	LLAVE T (5)	CLÉ (5)	1			D
17	22102-96530	SET PIN	PASADOR	GOUPILLE	1			D