

Re: Cylinder , Crankcase & Muffler

- 1 -

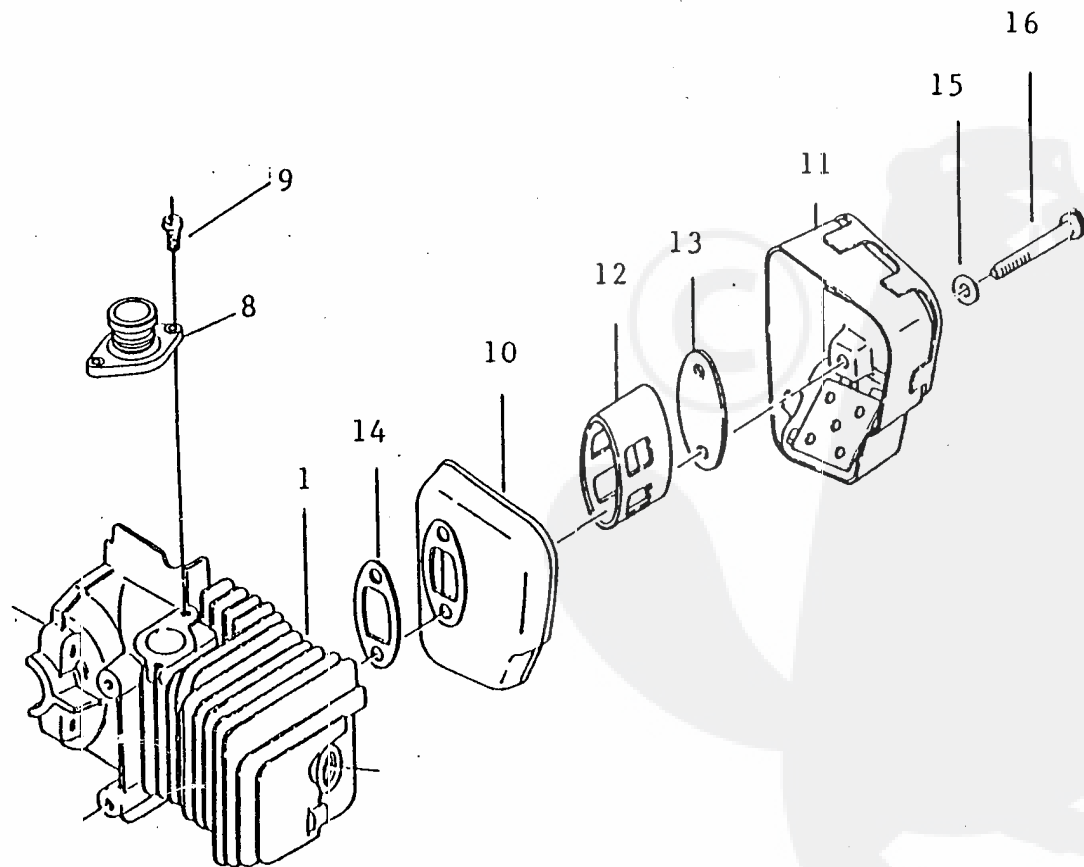
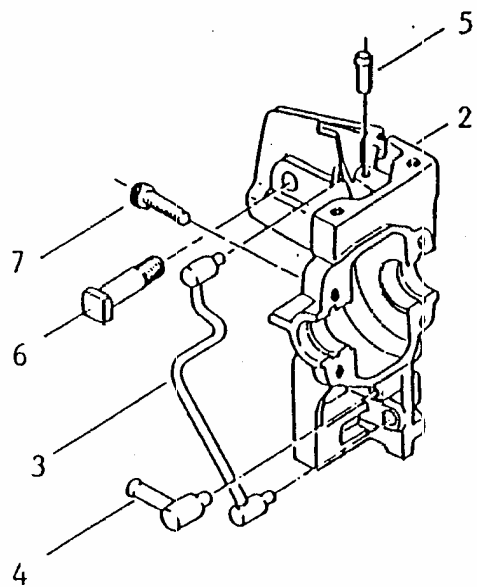

<1306-151.000010>>

1. CYLINDER
CRANKCASE
MUFFLER

Ref No	Part Name	Part No	Qty
1- 1	CYLINDER	22123-12112	1
	CRANKCASE ASSY	22106-12200	1
1- 2 *	CRANKCASE	22100-12210	1
1- 3 *	OIL PIPE, crankcase	22106-12230	1
1- 4 *	ELBOW, crankcase	22102-12240	1
1- 5 *	PULSE JOINT	22102-12250	1
1- 6 *	BOLT, bar	22120-12260	2
1- 7	BOLT	01020-05180	4
1- 8	BOOT	22136-14130	1
1- 9	SCREW	01212-04140	2
	MUFFLER ASSY	22135 15000	1
1-10 *	BASE, muffler	22104-15110	1
1-11 *	COVER, muffler	22135-15120	1
1-12 *	PIPE, muffler	22135-15130	1
1-13 *	PLATE, muffler	22135-15140	1
1-14 *	GASKET, muffler	22100-15210	1
1-15 *	WASHER	22100-31210	2
1-16 *	BOLT	01020-05450	2

2. ENGINE COVER

Ref No	Part Name	Part No	Qty
2- 1	ENGINE COVER	22104-31111	1
2- 2	NUMBER PLATE	72137-31150	1
2- 3	BOLT	01020-05100	1
2- 4	BOLT	01020-05250	1
2- 5	SPRING WASHER	01600-05131	5
2- 6	WASHER	01610-05080	4
2- 7	WASHER	22100-31210	1
2- 8	MOUNT	22100-31310	2
2- 9	MOUNT HOLDER	22100-31320	2
2-10	SIDE CUSHION	22100-31410	2
2-11	BOLT	01020 05100	6
2- 5	SPRING WASHER	01600-05131	6
2-12	SEAL	22100-31510	1
2-13	GROMMET	22100-31531	1
2-14	CHAIN CATCHER	22122 53410	1
2-15	BUSHING	22122-53420	1
2- 4	BOLT	01020-05250	1
2- 5	SPRING WASHER	01600-05131	1
2- 7	WASHER	22100-31210	1
2-16	SPIKE	22135-57610	1
2-11	BOLT	01020-05120	2
2- 5	SPRING WASHER	01600-05131	2

3. HANDLE

Ref No	Part Name	Part No	Qty
	BRACKET ASSY	22104-32100	1
3-1 *	BRACKET	22104-32110	1
3-2 *	CUSHION-22	22104-32120	1
3-3 -	CUSHION-18A	22102-32130	1
3-4 *	PLUG, bracket	22102-32140	1
3-5 *	BOLT, bracket	22102-32181	1
3-6 -	BOLT	01020-04100	2
3-7 *	SPRING WASHER	01600-04101	2
3-8 *	BOLT	01020-05120	1
3-9 *	SPRING WASHER	01600-05131	2
3-10 *	WASHER	01610-05080	1
3-11	FRONT HANDLE	22135-32150	1
3-12	CUSHION-22B	22135-32160	1
3-13	BOLT	01020-05250	2
3-9	SPRING WASHER	01600-05131	2
3-10	WASHER	01610-05080	2
	REAR HANDLE ASSY	72130-33000	1
*	REAR HANDLE SUB ASSY	72130-33100	1
3-14 **	REAR HANDLE	22131-33110	1
3-15 **	GRIP, handle	22104-33121	1
3-16 **	THROTTLE LEVER	22104-33130	1
3-17 **	LOCK LEVER	22104-33140	1
3-18 **	SPRING, lever	22106-33150	1
3-19 **	SPRING PIN	22100-33160	2
3-20 **	STOPPER	22100-33171	1

< BLG-151.000031 >

Ref No	Part Name	Part No	Qty
3-21 **	SPRING	22100-33180	1
3-22 **	KNOB, stopper	22100-33190	1
3-23 **	CAUTION PLATE-3	72139-33210	1
3-24 *	GROMMET, A	22100-33310	2
3-25 *	GROMMET, carburetor	22100-33320	1
3-26 *	GROMMET, rod	22100-33331	1
3-27 *	ADJUST SCREW	22122-33410	1
3-28 *	SPRING, adjust	22122-33420	1
3-29 *	SWITCH ASSY	22104-33500	1
**	SWITCH	22100-33510	1
**	NET	22100-33531	1
3-30	SPRING	22104-33610	1
3-31	BOLT	22100-33810	2
3-9	SPRING WASHER	01600-05131	2

Re: Piston , Crank shaft

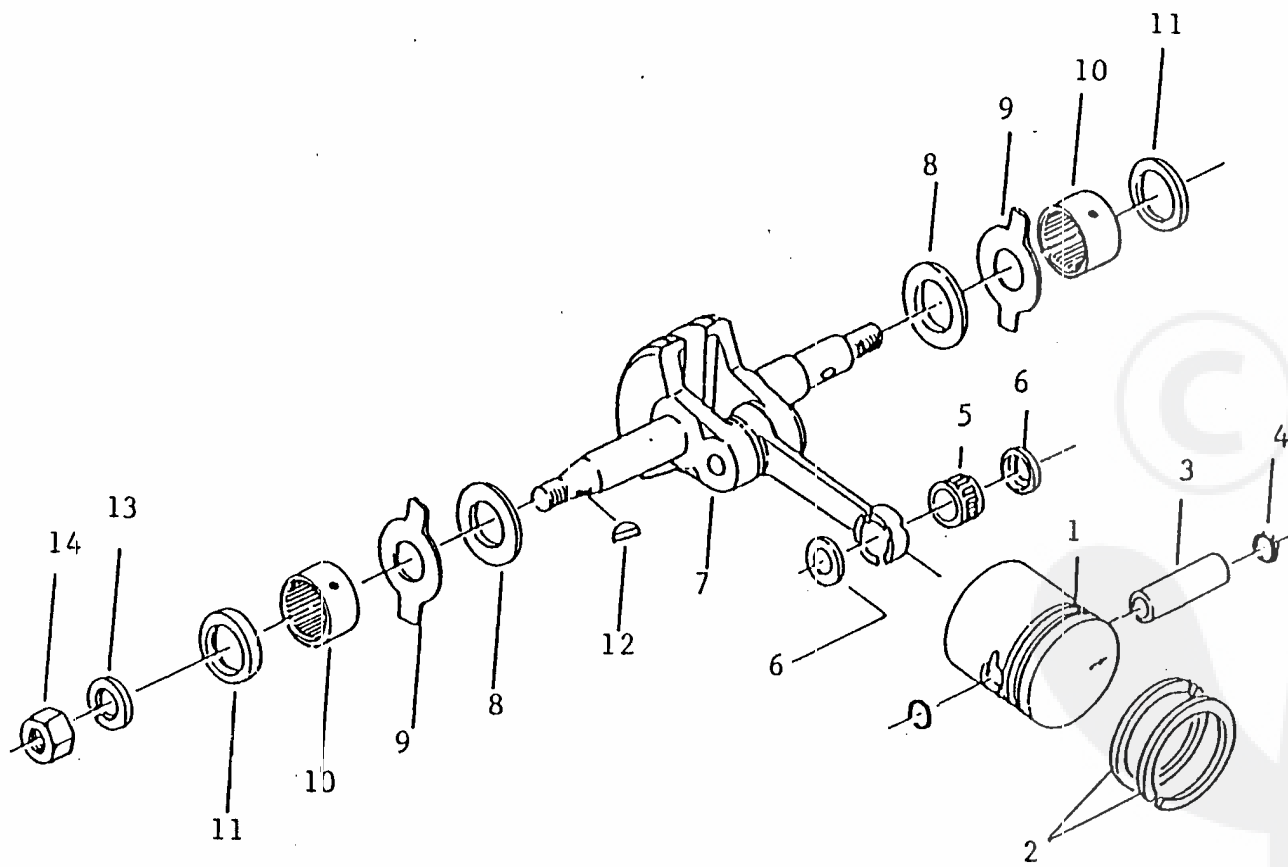

4. PISTON
CRANKSHAFT

Ref No	Part Name	Part No	Qty
4- 1	PISTON	22128-41110	1
4- 2	PISTON RING	22128-41210	2
4- 3	PISTON PIN	22128-41220	1
4- 4	SNAP RING	22100-41230	2
4- 5	NEEDLE BEARING-SE	22120-41330	1
4- 6	THRUST WASHER	22120-41340	2
4- 7	CRANKSHAFT ASSY	22128-42001	1
4- 8	THRUST WASHER	22102-43110	2
4- 9	SIDE PLATE-A	22100-43140	2
4- 9	SIDE PLATE-B	22100-43150	2
4-10	NEEDLE BEARING-M	22120-43160	2
4-11	OIL SEAL	22100-43170	2
4-12	WOODRUFF KEY	22100-43210	1
4-13	SPRING WASHER	01600-08201	1
4-14	NUT	22100-43231	1

Clearance between crankcase and side plate is to be adjusted 0.07~0.24 mm. Never use side plate with combination of "A" and "B". i.e. always use "A" and "A" or "B" and "B".

Re: Clutch , Cutting equipment

- 10 -

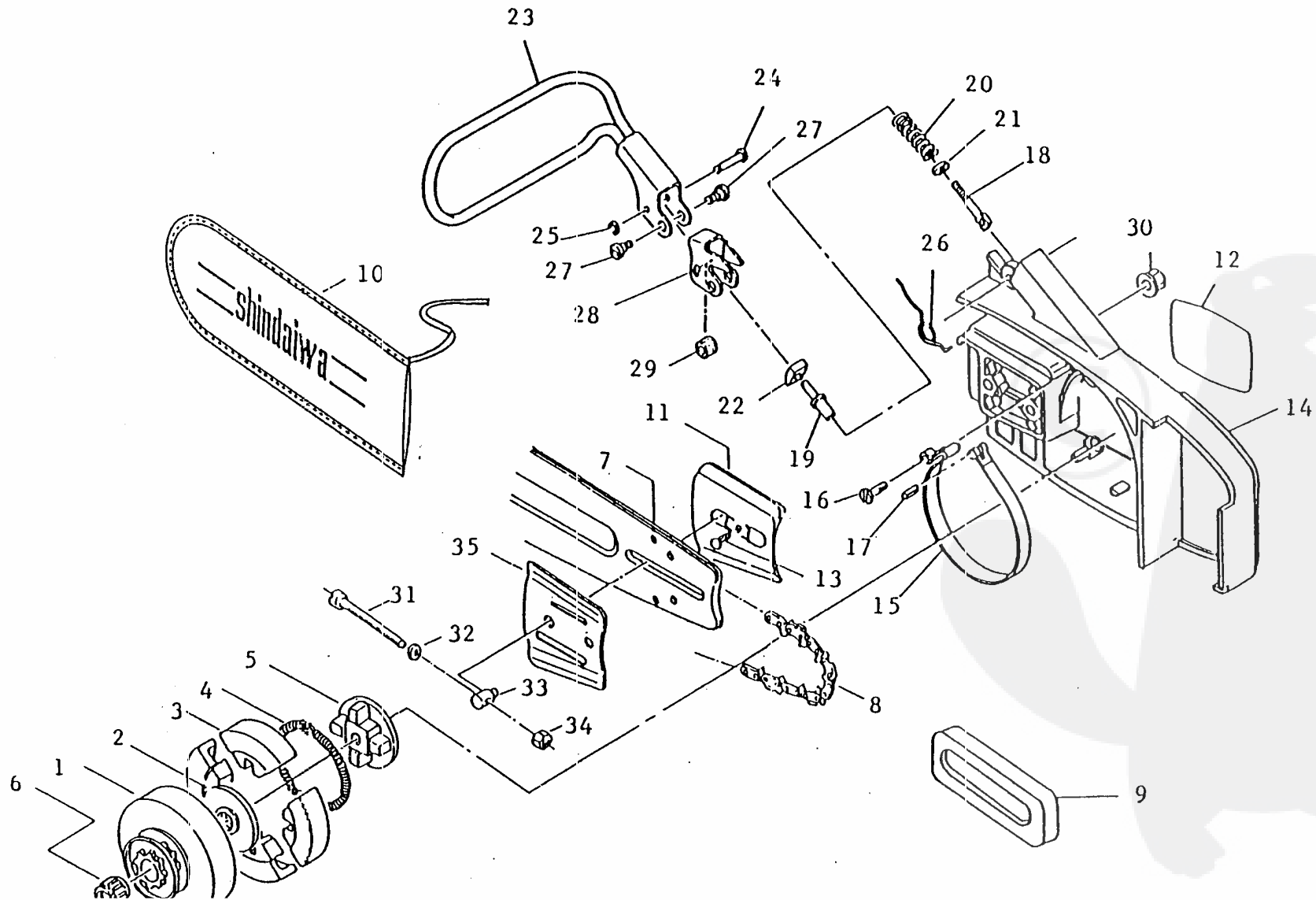

<<DLG 451.000050>>

5. CLUTCH
CUTTING EQUIPMENT

Ref No	Part Name	Part No	Qty
5-1	CLUTCH DRUM 325	22120-51111	1
	CLUTCH ASSY	22120-51200	1
5-2 *	CLUTCH BOSS-A	22120-51210	1
5-3 *	CLUTCH SHOE	22100-51220	4
5-4 *	CLUTCH SPRING	22102-51230	1
5-5 *	CLUTCH BOSS-B	22100-51240	1
5-6	NEEDLE BEARING	22102-51310	1
5-7	GUIDE BAR	72162-52110	1
5-8	SAW CHAIN	18074-00720	1
5-9	SPACER	22128-52230	1
5-10	PROTECTOR	22120-52311	1
	BRAKE ASSY	72139-54002	1
	* CLUTCH COVER SUB ASSY	72139-54100	1
5-11 **	GUIDE PLATE-B	22104-53120	1
5-12 **	NAME PLATE-A	72139-53130	1
5-13 **	PARKER RIVET	17100-25640	1
5-14 **	CLUTCH COVER	22131-54110	1
5-15 *	BRAKE BAND	22120-54210	1
5-16 *	BOLT, band	22120-54220	1
5-17 *	SPRING PIN	22120-54230	1
5-18 *	ADJUST ROD	72152-54310	1
5-19 *	ADJUST SCREW	72152-54320	1
5-20 *	BRAKE SPRING	22120-54330	1
5-21 *	WASHER	22120-54340	1
5-22 *	BLOCK	22120-54410	1

<<BLG-451.000051>>

Ref No	Part Name	Part No	Qty
5-23 *	LEVER	22135-54510	1
5-24 *	STOPPER PIN	22135-54520	1
5-25 *	E-RING	22120-54530	1
5-26 *	RELIEF SPRING	22135-54540	1
5-27 *	BOLT, lever	22135-54550	2
5-28 *	LEVER-C	72171-54560	1
5-29 *	CUSHION	22135-54570	1
5-30	NUT	22120-53210	2
5-31	SLIDE SCREW	22100-53310	1
5-32	WASHER	01610-05080	1
5-33	SLIDE PIECE	22100-53320	1
5-34	LOCK NUT	22100-53330	1
5-35	GUIDE PLATE-A	22100-53340	1



Re: Oil pump

- 13 -

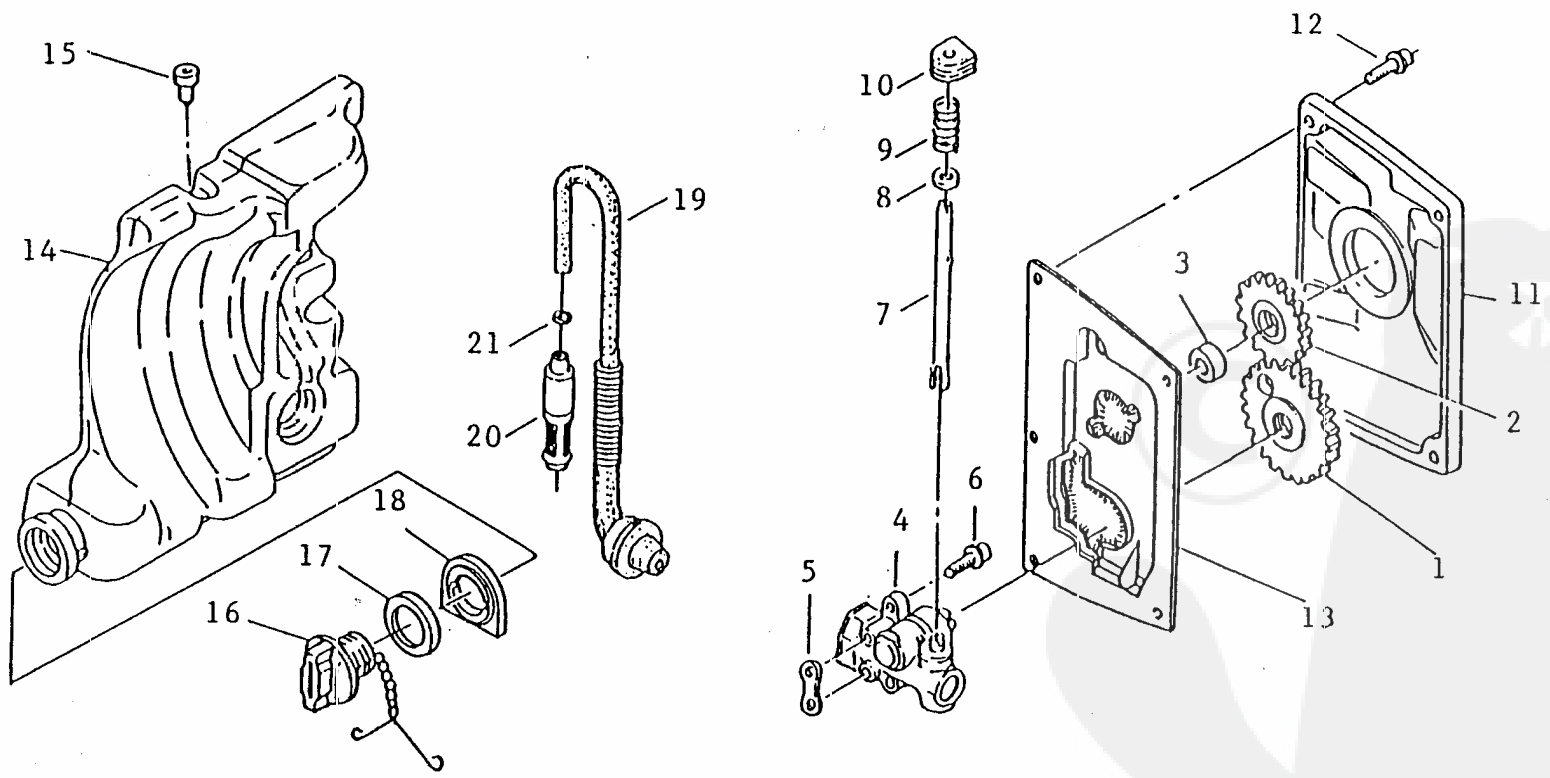

<<BLG-451.000000>>

6. O I L P U M P

Ref No	Part Name	Part No	Qty
6-1	GEAR	22128-55120	1
6-2	PINION	22102-55130	1
6-3	COLLAR	22102-55141	1
6-4	OIL PUMP ASSY	22136-55200	1
6-5	GASKET, oil pump	22100-55310	1
6-6	SCREW	11206-04140	2
6-7	SHAFT, oil pump	22100-55610	1
6-8	WASHER	01610-04050	1
6-9	SPRING	22100-55640	1
6-10	GROMMET, oil pump	22100-55650	1
6-11	PUMP COVER	22104-56110	1
6-12	SCREW	11205-04140	5
6-13	DUST COVER	22122-56210	1
	OIL TANK ASSY	22140-57000	1
6-14 *	OIL TANK	22140-57110	1
6-15 *	VALVE, oil tank	22100-57120	1
	OIL CAP ASSY	22128-57200	1
6-16 **	OIL CAP	22128-57210	1
6-17 **	GASKET, oil cap	22100-57230	1
6-18 *	TANK SUPPORT, oil	22122-57240	1
	OIL PIPE ASSY	22122-57301	1
6-19 **	OIL PIPE	22122-57311	1
6-20 **	OIL FILTER	22100-57360	1
6-21 **	CLIP, oil filter	22100-57370	1

Re: Magneto

- 15 -

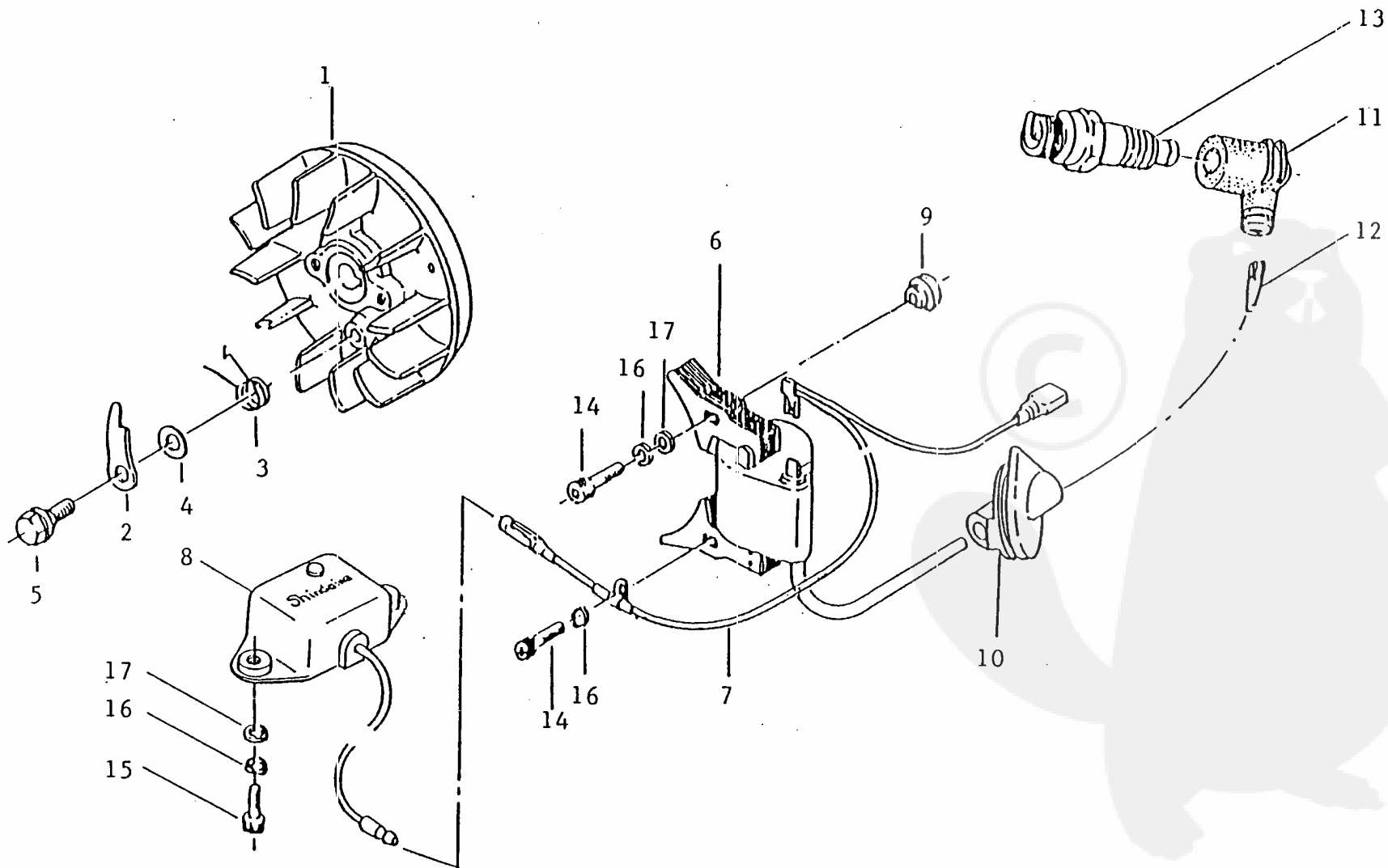

7. MAGNETO

Ref No	Part Name	Part No	Qty
	ROTOR ASSY	22128-71100	1
7- 1 *	ROTOR	22104-71200	1
7- 2 *	RATCHET	22100-71410	2
7- 3 *	SPRING, ratchet	22100-71420	2
7- 4 *	WASHER	22100-71430	2
7- 5 *	BOLT	22100-71441	2
	COIL ASSY	22128-71602	1
7- 6 *	COIL	22128-71611	1
7- 7 *	CORD	22128-71620	1
7- 8	UNIT	22128-71700	1
7- 9	SPACER, coil	22100-72110	2
7-10	GROMMET	22104-72210	1
7-11	PLUG CAP	20010-72221	1
7-12	SPRING, spark plug	20000-72230	1
7-13	SPARK PLUG	22100-73111	1
7-14	BOLT	01020-04240	2
7-15	BOLT	01020-04100	2
7-16	SPRING WASHER	01600-04101	4
7-17	WASHER	01610-04050	3

Re: Recoil starter

- 17 -

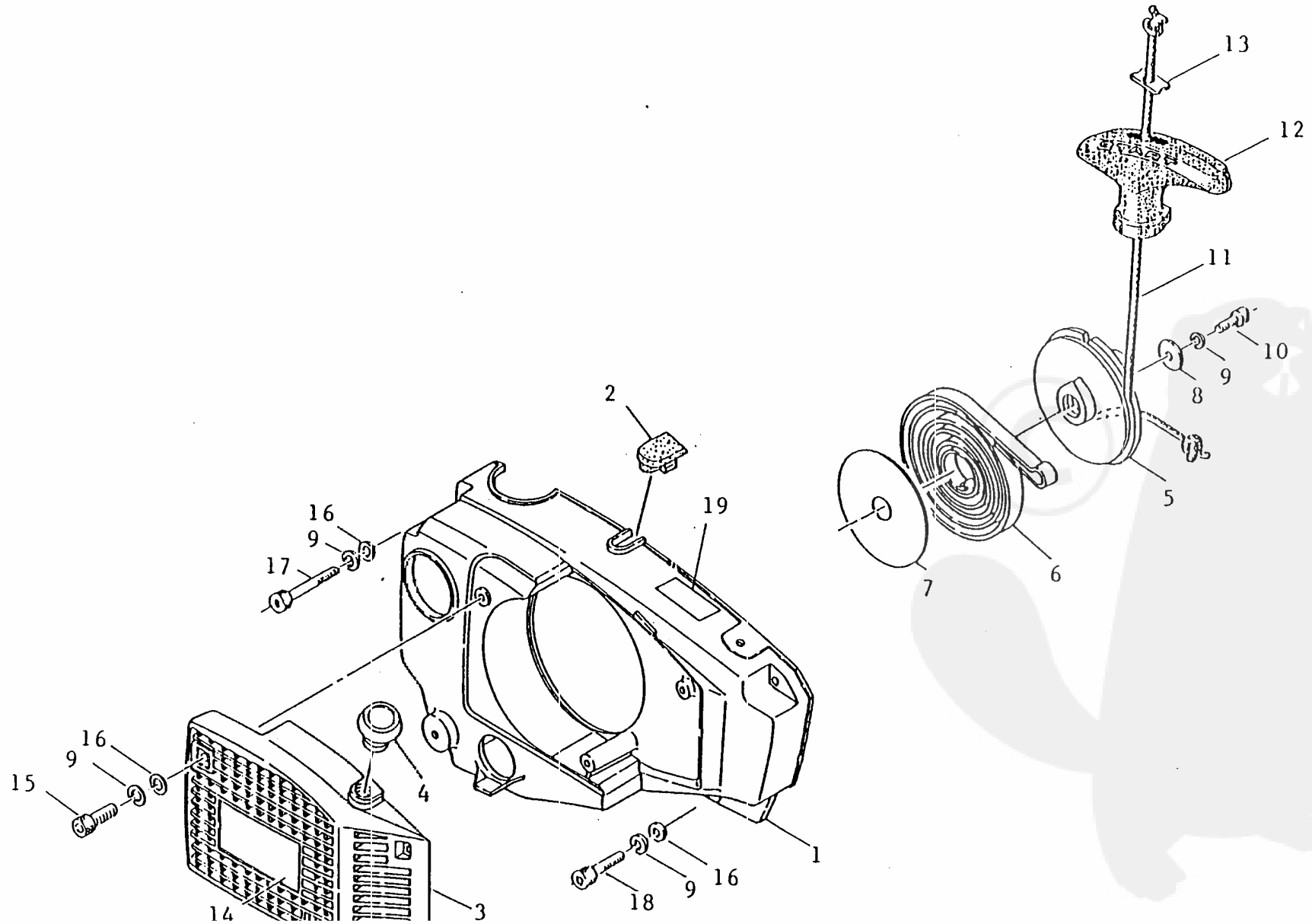

8. RECOIL STARTER

Ref No	Part Name	Part No	Qty
	FAN COVER ASSY	72148-75900	1
*	FAN COVER SUB ASSY	72148-75100	1
8- 1 **	FAN COVER	22135-75110	1
8- 2 **	PLUG, recoil case	22122-75160	1
*	RECOIL STARTER ASSY	72137-76000	1
8- 3 **	RECOIL CASE	22135-76110	1
8- 4 **	GUIDE	22104-75130	1
8- 5 **	REEL	22104-76210	1
8- 6 **	RECOIL SPRING	22106-75310	1
8- 7 **	PLATE-A	22104-75330	1
8- 8 **	WASHER	22104-75350	1
8- 9 **	SPRING WASHER	01600-04101	1
8-10 **	BOLT	01020-04100	1
8-11 **	ROPE	22104-75410	1
8-12 **	KNOB, recoil	22104-75420	1
8-13 **	STOPPER, knob	22104-75430	1
8-14 **	NAME PLATE-B	72137-76120	1
8-15 *	BOLT	01020-04120	3
8- 9 *	SPRING WASHER	01600-04101	3
8-16 *	WASHER	01610-04050	3
8-17	BOLT	01020-04350	2
8-18	BOLT	01020-04240	2
8- 9	SPRING WASHER	01600-04101	4
8-16	WASHER	01610-04050	4
8-19	CAUTION PLATE-A, fan cover	72156-75170	1

Re: Carburetor

- 19 -

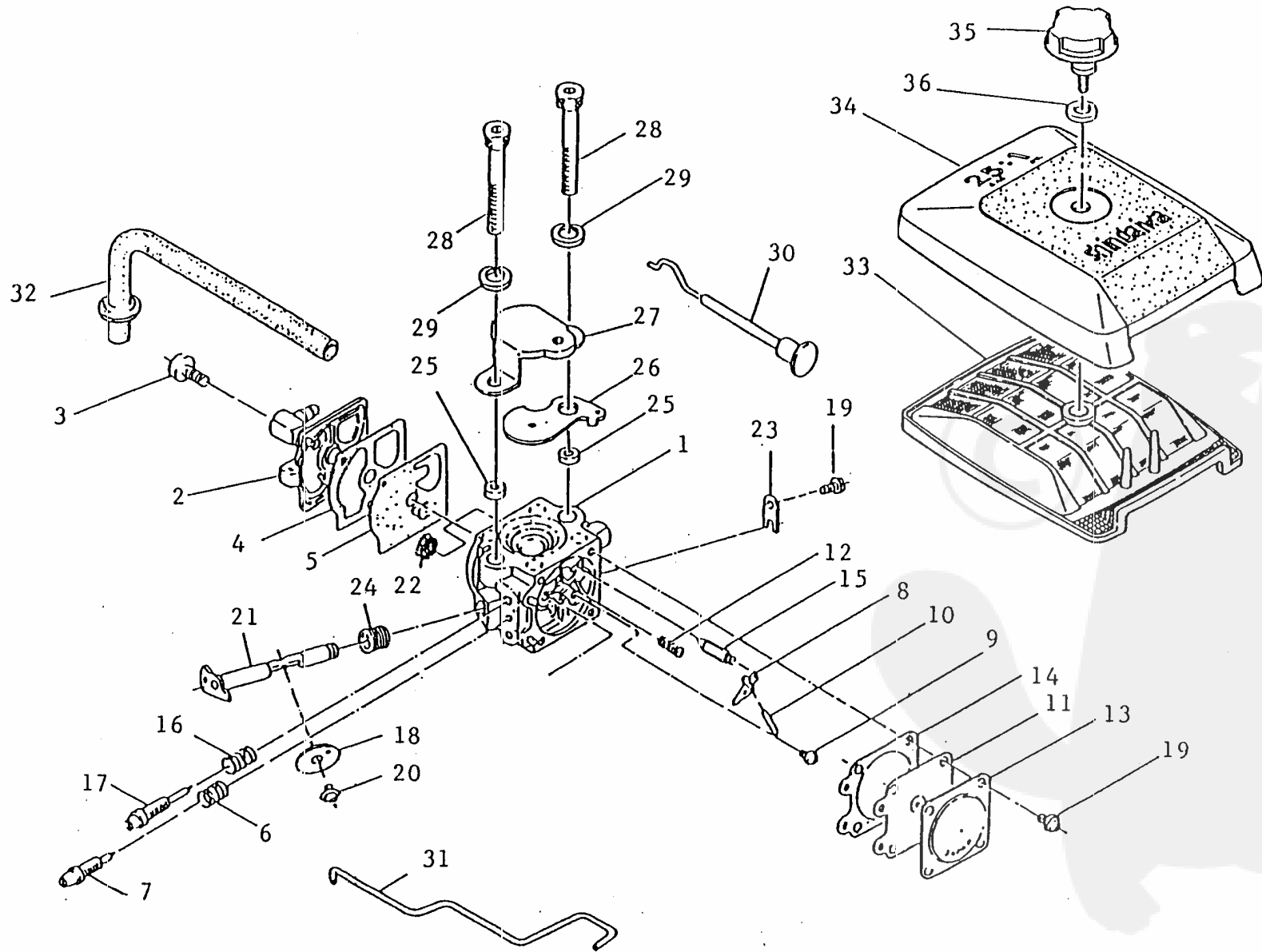

<<BLG-451.000099>>

9. CARBURETOR

Ref No	Part Name	Part No	Qty
	CARBURETOR ASSY	22128-81092	1
9-1*	BODY ASSY	22128-81111	1
9-2*	PUMP COVER ASSY	22128-81129	1
9-3*	SCREW	22100-81130	1
9-4*	GASKET, pump cover	22128-81140	1
9-5*	DIAPHRAGM, pump	22128-81150	1
9-6*	SPRING, L-needle	22100-81160	1
9-7*	L-NEEDLE	22128-81171	1
9-8*	LEVER	22100-81230	1
9-9*	SCREW	22100-81240	1
9-10*	PIN	22100-81250	1
9-11*	DIAPHRAGM ASSY	22100-81260	1
9-12*	SPRING, lever	22104-81270	1
9-13*	COVER, diaphragm	22100-81280	1
9-14*	GASKET, diaphragm	22100-81290	1
9-15*	NEEDLE VALVE	22100-81310	1
9-16*	SPRING, H-needle	22100-81320	1
9-17*	H-NEEDLE	22104-81330	1
9-18*	THROTTLE VALVE	22104-81340	1
9-19*	SCREW ASSY	22100-81351	5
9-20*	SCREW	22100-81360	1
9-21*	SHAFT ASSY	22100-81370	1
9-22*	SCREEN	22128-81380	1
9-23*	CLIP, shaft	22100-81390	1
9-24*	SPRING, shaft	22100-81410	1

Ref No	Part Name	Part No	Qty
9-25	WASHER, carburetor	22100-82110	2
9-26	CHOKE PLATE	22120-82120	1
9-27	BRACKET, carburetor	22128-82130	1
9-28	BOLT	01020-05400	2
9-29	SPRING WASHER	01600-05131	2
9-30	CHOKE ROD	22102-82140	1
9-31	THROTTLE ROD	22100-82212	1
9-32	PULSE PIPE	22104-82220	1
9-33	AIR CLEANER	22135-82310	1
	CLEANER COVER SUB ASSY	22135-82400	1
9-34 *	CLEANER COVER	22135-82410	1
9-35 *	KNOB, cleaner cover	22128-82420	1
9-36 *	O-RING	22100-82430	1
	DIAPHRAGM KIT	22128-81910	1
9-5 *	DIAPHRAGM, pump	22128-81150	1
9-11 *	DIAPHRAGM ASSY	22100-81260	1
	GASKET KIT	22128-81920	1
9-4 *	GASKET, pump cover	22128-81140	1
9-14 *	GASKET, diaphragm	22100-81290	1

Re: Fuel tank

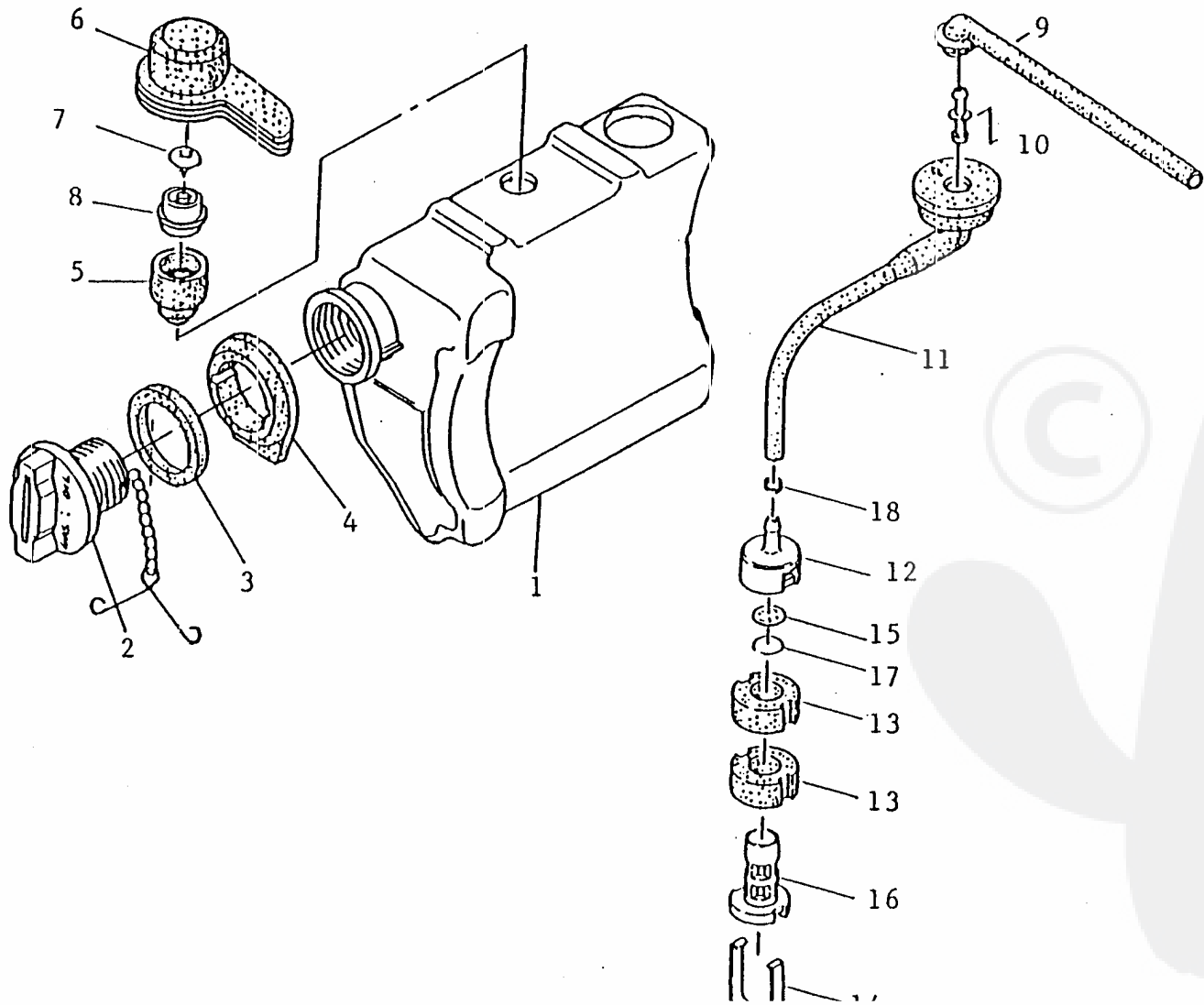

<<345-451.000100>>

10. FUEL TANK

Ref No	Part Name	Part No	Qty
	FUEL TANK ASSY	22135-85000	1
10-1 *	FUEL TANK	22135-85110	1
	FUEL CAP ASSY	22128-85200	1
10-2 **	FUEL CAP	22128-85210	1
10-3 **	GASKET, fuel cap	22100-85281	1
10-4 *	TANK SUPPORT, fuel	22122-85230	1
10-5 *	HOLDER, valve	22122-85240	1
10-6 *	CAP, breather	22122-85250	1
10-7 *	VALVE, fuel	22100-85260	1
10-8 *	RETAINER, breather	22122-85270	1
10-9 *	FUEL PIPE	22104-85310	1
10-10 *	JOINT, fuel pipe	22100-85320	1
	SUCTION PIPE ASSY	22128-85300	1
10-11 **	SUCTION PIPE	22128-85330	1
	FUEL FILTER SUB ASSY	22128-85401	1
10-12 ***	WEIGHT, fuel	22128-85410	1
10-13 ***	FILTER	22128-85421	2
10-14 ***	CLIP, filter	22128-85440	1
10-15 ***	SCREEN	22128-85461	1
10-16 ***	SLEEVE	22128-85470	1
10-17 ***	RING	22128-85480	1
10-18 ***	CLIP	20020-85540	1

22128-85301

Re: Tool set

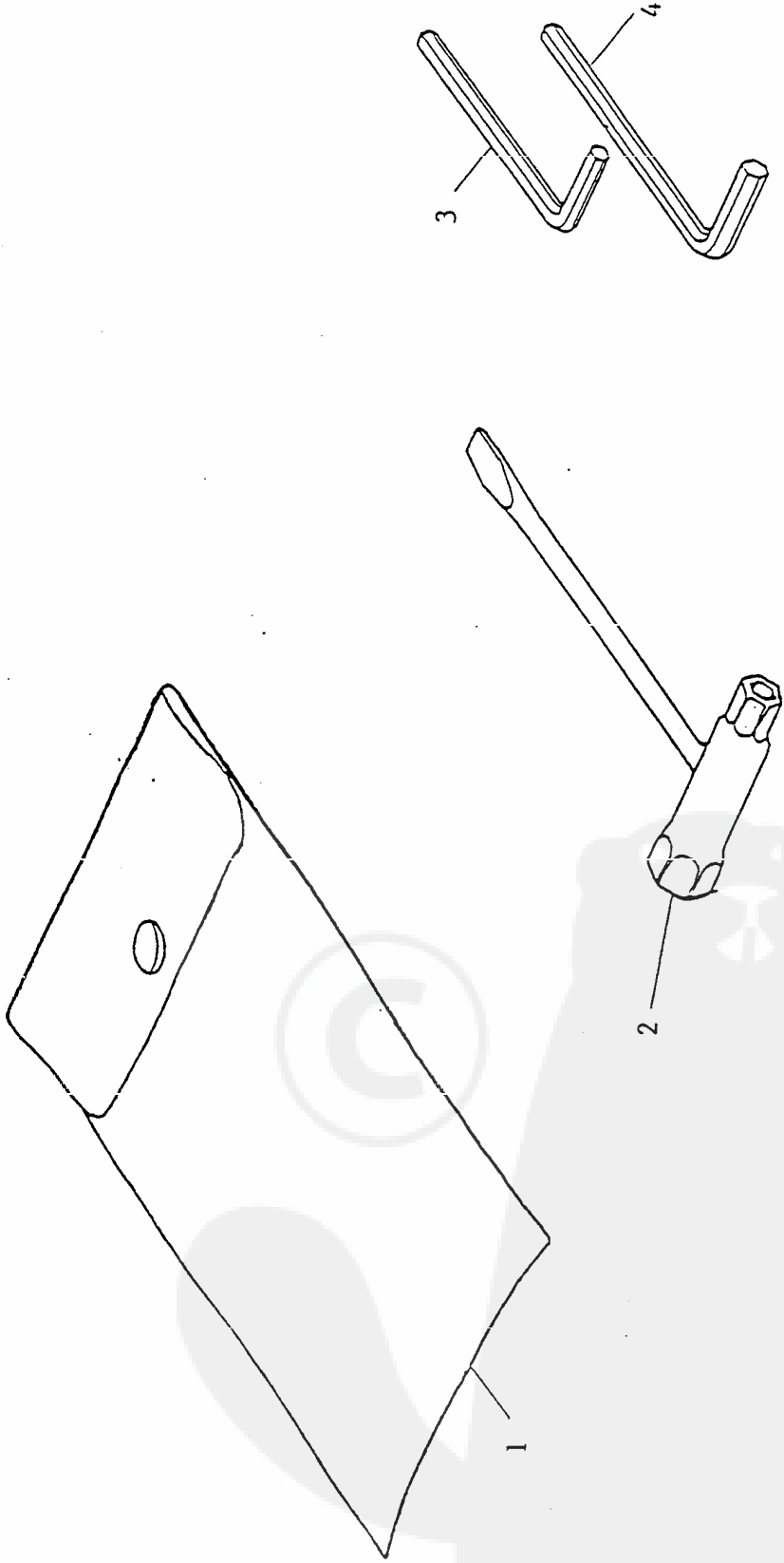

<<BLG-451.000110>>

11. TOOL SET

Ref No	Part Name	Part No	Qty
	TOOL SET	72102-91000	1
11- 1 *	TOOL BAG	72102-91110	1
11- 2 *	PLUG WRENCH	22102-91410	1
11- 3 *	WRENCH	22100-91551	1
11- 4 *	WRENCH	22100-91561	1

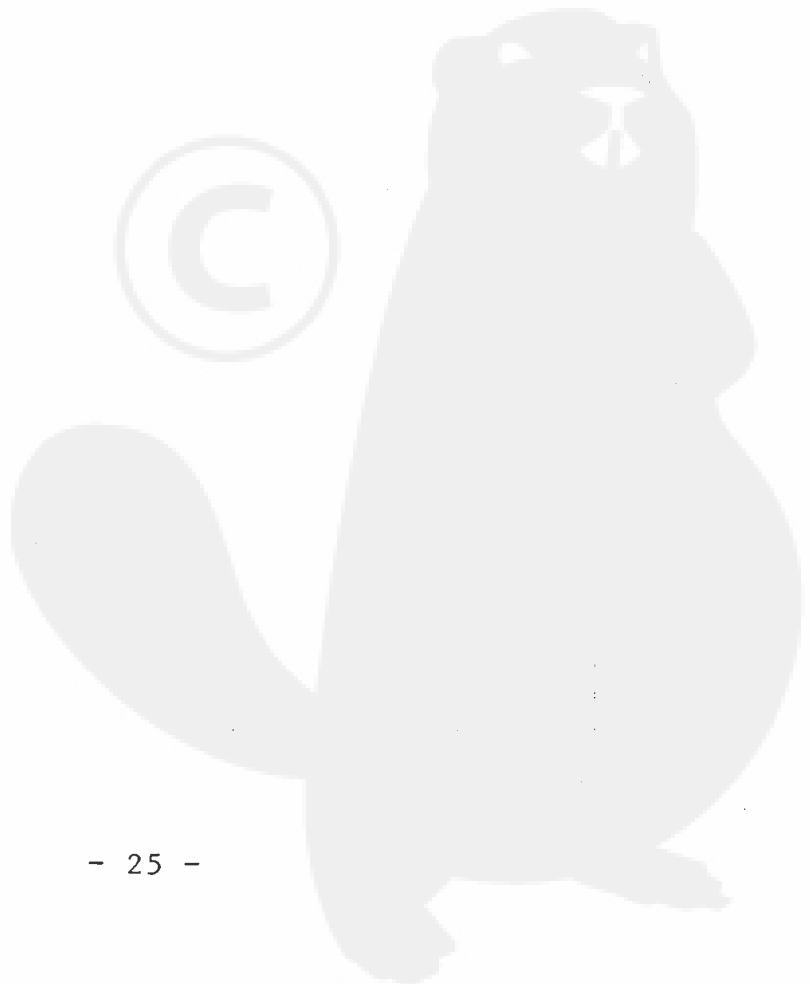

Re: Option

- 26 -

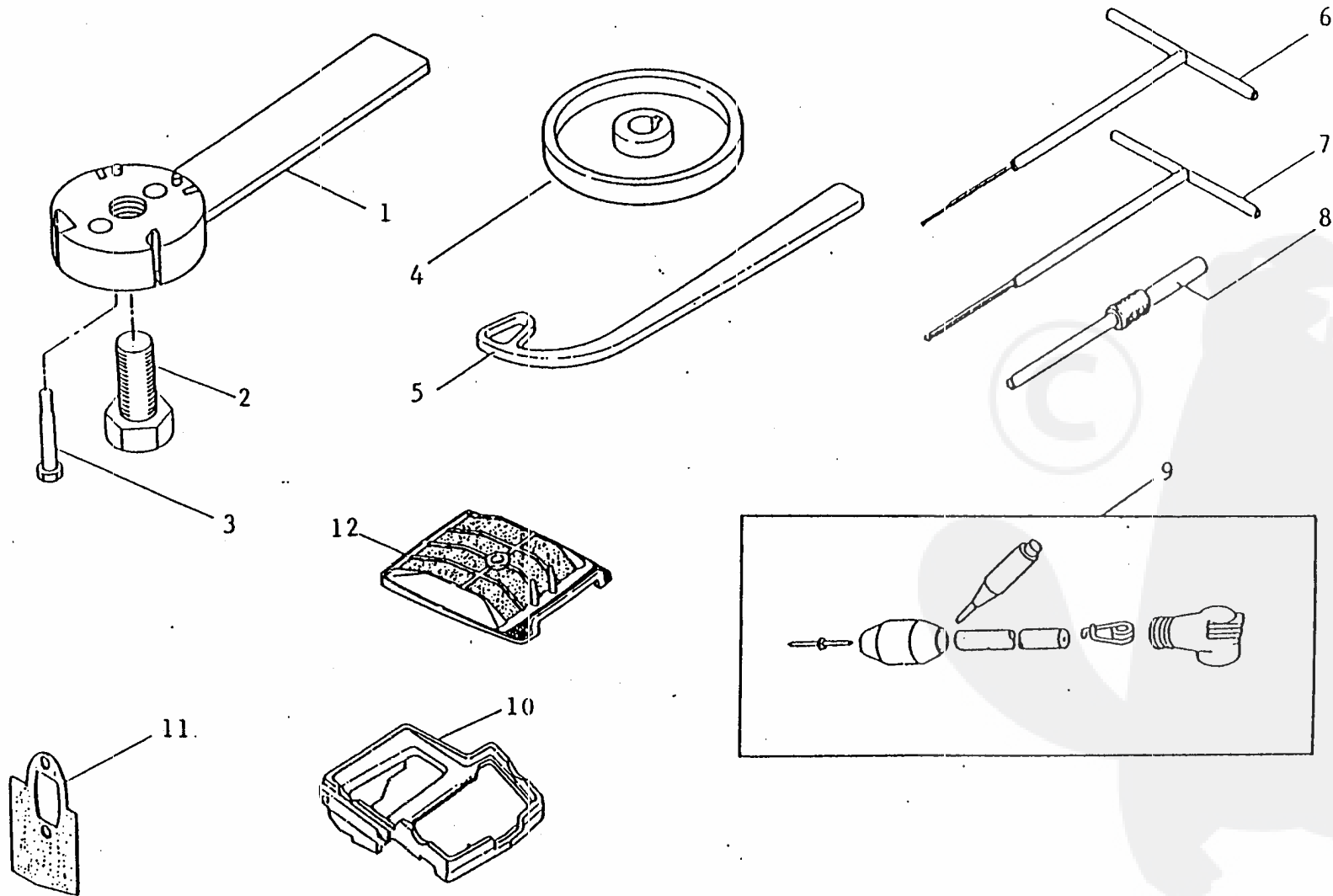

<<BLG-451.000120>>

1 2 . S P E C I A L T O O L S E T

Ref No	Part Name	Part No	Q'ty
	SPECIAL TOOL SET	22104-96000	1
*	PULLER ASSY	22104-96100	1
12- 1 **	PULLER	22104-96110	1
12- 2 **	CENTER BOLT	22100-96121	1
12- 3 **	BOLT	22102-96130	2
12- 4 *	SET GAUGE	22102-96211	1
12- 5 *	STOPPER	22100-96410	1
12- 6 *	T-WRENCH-4	22102-96510	1
12- 7 *	T-WRENCH-5	22102-96520	1
12- 8 *	SET PIN	22102-96530	1
12- 9	REPAIR KIT	22104-97800	1
12-10	AIR DUCT	22102-97510	1
12-11	GASKET, muffler	22102-97540	1
12-12	AIR CLEANER-A	22135-97520	1