

ELECTRIC CHAIN SAW  
MODEL A - 105B

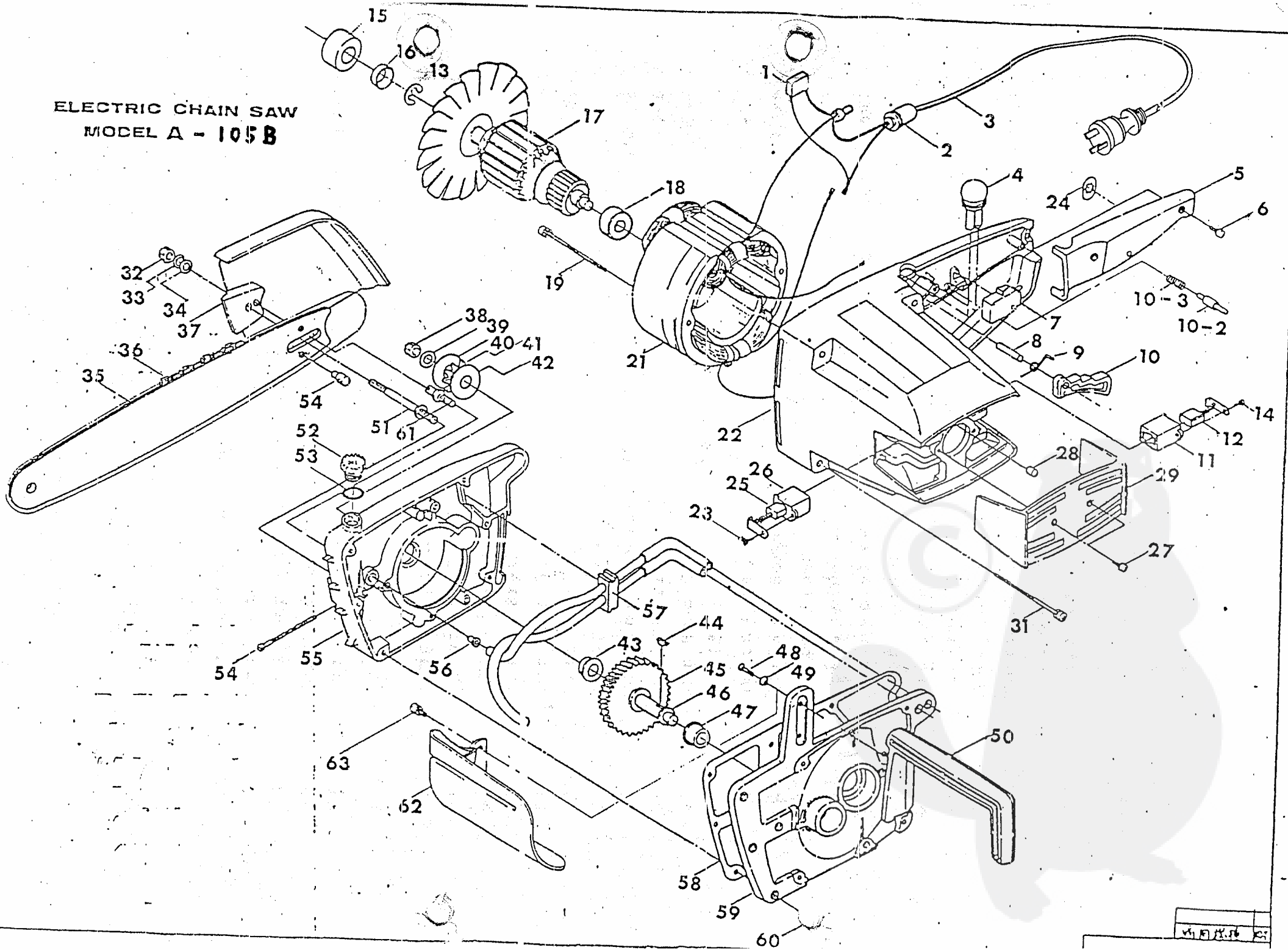

INGEKOMEN 2 9 MEI 1990

Parts List for Electric Chain Sa

Model  Wood Pe

Ref. No.	Part Name	Q'ty
1	Condenser	1
2	Cord Protection Rubber	1
3	Cord Set	1
4	Oil Pump 23111-63200	1
5	Rear Handle Cover	1
6	Pan Head Screw	2
7	Switch	1
8	Trigger Pin	1
9	Trigger Spring	1
10	Trigger	1
11	Brush Holder	1
12	Carbon Brush 14731-06121	1
14	Pan Head Screw	1
15	Ball Bearing	1
16	Retaining Ring Cap	1
17	Armature (Incl. 16, 18)	1
18	Ball Bearing	1
19	Pan Head Screw	2
21	Field	1
22	Motor Case	1
23	Pan Head Screw	1
25	Carbon Brush	1
26	Brush Holder	1
27	Pan Head Screw	2
28	Bearing Rubber	1
29	End Cover	1
31	Pan Head Screw	4
32	Hexagon Nut	1
33	Spring Washer	1
34	Flat Washer	1
35	Guide Bar	1
36	Saw Chain	1
37	Guide Bar Pressure	1
38	U Nut	1
39	Flat Washer	1

Parts List for Electric Chain Saw  
Model: A-105B

Ref. No.	Part Name	Q'ty	Remarks
40	Side Plate 23111-62110	1	
41	Sprocket 12030-07100	1	
42	Side Plate	1	
43	Oilless Metal (B)	1	
44	Woodruff Key	1	
45	Gear	1	
46	Main Shaft	1	
47	Oilless Metal (A)	1	
48	Round Plate Screw	1	
49	Toothed Washer	2	
50	Front Handle	1	
51	Guide Bar Bolt	1	
52	Oil Cap	1	
53	O Ring	1	
54	Chain Adjusting Screw	1	
55	Gear Case (B) (Incl.61)	1	
56	Discharge Valve	1	
57	Tube Assy	1	
58	Packing	1	
59	Gear Case (A)	1	
60	Pan Head Screw	10	
61	Guide Bar Bolt	1	
10-2	Lock Button	1	
10-3	Lock Spring	1	
13, 24	Spring Ring	2	
	* Hand Guard	1	
	* Pan Head Screw for Hand Guard		
	* Terminal		
	(* mark for request)		